



City of Chicago Office of the City Clerk

City Hall
121 North LaSalle Street
Room 107
Chicago, IL 60602
www.chicityclerk.com

Legislation Referred to Committees at the Chicago City Council Meeting 10/21/2015

Section 3c - Aldermanic Introductions Regarding Unclassified Matters

File #	Title	Sponsor(s)	Committee Referral
4-60-022 Allow Alcoholic Liquor			
1	O2015-7694	Amendment of Municipal Code Section 4-60-022 (10.162) to allow additional alcoholic liquor licenses on portion(s) of E 135th St and S Baltimore Ave	Sadlowski Garza (10) License
2	O2015-7696	Amendment of Municipal Code Section 4-60-022 (23.9) to allow additional alcoholic liquor licenses on portion(s) of W Archer Ave	Burke (14) License
Alley Access Barrier(s)			
3	O2015-7698	Exemption from physical barrier requirement for commercial driveway alley access for Maribis of Chicago LLC	Burke (14) Transportation
4	O2015-7688	Exemption from physical barrier requirement for commercial driveway alley access for Flexible Services and Construction, Inc. d.b.a. E&E Builders	Maldonado (26) Transportation
5	O2015-7689	Exemption from physical barrier requirement for commercial driveway alley access for 1524-1534 N Pulaski LLC	Maldonado (26) Transportation
6	O2015-7691	Exemption from physical barrier requirement for commercial driveway alley access for KMDM Properties	O'Connor (40) Transportation
7	O2015-7690	Exemption from physical barrier requirement for commercial driveway alley access for Via Veneto Condo Assn.	Cappleman (46) Transportation
Amend Order			
8	Or2015-648	Commissioner of Business Affairs and Consumer Protection directed to update assessed land values utilized for setting price of sidewalk cafe permits	Arena (45) Hairston (5) Sawyer (6) Sadlowski Garza (10) Foulkes (16) Moore (17) Waguespack (32) Munoz (22) Ramirez-Rosa (35) License
Awning(s)			
9	O2015-7732	Awning(s) for Honey's	Burnett (27) Transportation
10	O2015-7729	Awning(s) for Good Shepherd Healthcare LLC	Mell (33) Transportation
Canopy(s)			
11	O2015-7739	Canopy(s) for Walgreens No. 05356	Lopez (15) Transportation

Legislation Referred to Committees at the Chicago City Council Meeting

10/21/2015

Section 3c - Aldermanic Introductions Regarding Unclassified Matters

File #	Title	Sponsor(s)	Committee Referral	
12	O2015-7740	Canopy(s) for Paola's Hair Salon	Villegas (36)	Transportation
Committee/Public Hearing(s)				
13	R2015-829	Call for U.S. Congress and Illinois General Assembly to take action to ensure railroads are sufficiently regulated	Villegas (36) O'Shea (19) Ramirez-Rosa (35) Waguespack (32) Cochran (20) Sposato (38) Reboyras (30) Taliaferro (29) Moreno (1) Maldonado (26) Laurino (39) Solis (25) Scott, Jr. (24) Mitts (37) Munoz (22) Quinn (13) Foulkes (16) Moore (17) Curtis (18) Zalewski (23) Lopez (15)	Health & Environment
Grant(s) of Privilege				
14	O2015-7711	Grant(s) of privilege in public way for Cheesie's Pub & Grub	Moreno (1)	Transportation
15	O2015-7714	Grant(s) of privilege in public way for Whiskey Business	Moreno (1)	Transportation
16	O2015-7717	Grant(s) of privilege in public way for Northwestern Memorial Hospital - catch basins	Hopkins (2)	Transportation
17	O2015-7721	Grant(s) of privilege in public way for Northwestern Memorial Hospital - grease trap	Hopkins (2)	Transportation
18	O2015-7724	Grant(s) of privilege in public way for Northwestern Memorial Hospital - manhole	Hopkins (2)	Transportation
19	O2015-7726	Grant(s) of privilege in public way for Norfolk Southern Railway Co.	Dowell (3)	Transportation
20	O2015-7730	Grant(s) of privilege in public way for Ancona School	Burns (4)	Transportation
21	O2015-7731	Grant(s) of privilege in public way for Subway	Burns (4)	Transportation
22	O2015-7736	Grant(s) of privilege in public way for Chicago Park District-Office of Comptroller	Hairston (5)	Transportation
23	O2015-7743	Grant(s) of privilege in public way for Walgreens No. 05356 - light fixtures	Lopez (15)	Transportation
24	O2015-7746	Grant(s) of privilege in public way for Walgreens No. 05356 - sign	Lopez (15)	Transportation
25	O2015-7750	Grant(s) of privilege in public way for Walgreens No. 06641 - light fixtures	Lopez (15)	Transportation

Legislation Referred to Committees at the Chicago City Council Meeting
10/21/2015

Section 3c - Aldermanic Introductions Regarding Unclassified Matters

File #	Title	Sponsor(s)	Committee Referral	
26	O2015-7751	Grant(s) of privilege in public way for Walgreens No. 06641 - occupation of space	Lopez (15)	Transportation
27	O2015-7752	Grant(s) of privilege in public way for Walgreens No. 06641 - sign	Lopez (15)	Transportation
28	O2015-7753	Grant(s) of privilege in public way for University of Chicago, The (File No. 30)	Cochran (20)	Transportation
29	O2015-7754	Grant(s) of privilege in public way for Walgreens No. 2711	Zalewski (23)	Transportation
30	O2015-7756	Grant(s) of privilege in public way for Clipper/CC Ferns, The	Maldonado (26)	Transportation
31	O2015-7757	Grant(s) of privilege in public way for Grand Cafe	Burnett (27)	Transportation
32	O2015-7758	Grant(s) of privilege in public way for Ogden North LLC	Ervin (28)	Transportation
33	O2015-7760	Grant(s) of privilege in public way for Acceptance Insurance	Austin (34)	Transportation
34	O2015-7763	Grant(s) of privilege in public way for Black Tie Formalwear	Ramirez-Rosa (35)	Transportation
35	O2015-7765	Grant(s) of privilege in public way for Healthcare Alternatives	Villegas (36)	Transportation
36	O2015-7767	Grant(s) of privilege in public way for Lucki Communication	Villegas (36)	Transportation
37	O2015-7768	Grant(s) of privilege in public way for McGrath City Honda	Villegas (36)	Transportation
38	O2015-7770	Grant(s) of privilege in public way for Menasha Packaging Co. LLC	Villegas (36)	Transportation
39	O2015-7772	Grant(s) of privilege in public way for Walgreens No. 5121 - light fixtures	Villegas (36)	Transportation
40	O2015-7773	Grant(s) of privilege in public way for Walgreens No. 5121 - signs	Villegas (36)	Transportation
41	O2015-7759	Grant(s) of privilege in public way for AMC Dine-In Theatres Block 37 - banner	Reilly (42)	Transportation
42	O2015-7761	Grant(s) of privilege in public way for AMC Dine-In Theatres Block 37 - sign	Reilly (42)	Transportation
43	O2015-7762	Grant(s) of privilege in public way for Beacon Tavern	Reilly (42)	Transportation
44	O2015-7764	Grant(s) of privilege in public way for Northwestern University	Reilly (42)	Transportation
45	O2015-7766	Grant(s) of privilege in public way for Northwestern Memorial Hospital	Reilly (42)	Transportation
46	O2015-7769	Grant(s) of privilege in public way for RMW Streeterville LLC	Reilly (42)	Transportation
47	O2015-7771	Grant(s) of privilege in public way for Blackwood BBQ	Tunney (44)	Transportation
Grant(s) of Privilege - Amend				
48	O2015-7713	Amendment of grant(s) of privilege in public way for 2510 W Armitage Ave	Moreno (1)	Transportation
49	O2015-7718	Amendment of grant(s) of privilege in public way for Cafe Sushi-Wells	Hopkins (2)	Transportation

Legislation Referred to Committees at the Chicago City Council Meeting

10/21/2015

Section 3c - Aldermanic Introductions Regarding Unclassified Matters

File #	Title	Sponsor(s)	Committee Referral	
50	O2015-7722	Amendment of grant(s) of privilege in public way for Jimmy John's	Hopkins (2)	Transportation
51	O2015-7735	Amendment of grant(s) of privilege in public way for Restoration Hardware - awnings	Hopkins (2)	Transportation
52	O2015-7737	Amendment of grant(s) of privilege in public way for Restoration Hardware - canopy	Hopkins (2)	Transportation
53	O2015-7741	Amendment of grant(s) of privilege in public way for Restoration Hardware - light fixtures	Hopkins (2)	Transportation
54	O2015-7744	Amendment of grant(s) of privilege in public way for American Sightseeing/Gray Line Tours	Burns (4)	Transportation
55	O2015-7748	Amendment of grant(s) of privilege in public way for Nebel, Inc.	Burnett (27)	Transportation
56	O2015-7747	Amendment of grant(s) of privilege in public way for Irving Narragansett Partnership	Sposato (38)	Transportation
57	O2015-7749	Amendment of grant(s) of privilege in public way for Fairfield Inn & Suites-Downtown Chicago	Reilly (42)	Transportation
Municipal Code Amendment(s)				
58	O2015-7778	Amendment of Municipal Code Chapter 2-32 by adding new Section 2-32-627 establishing Property Tax Relief Program	Moreno (1) Smith (43) Hopkins (2) Moore (49) Osterman (48) Cappleman (46) Sadlowski Garza (10) Pawar (47) O'Connor (40) Dowell (3) Arena (45) Burns (4)	Finance

Legislation Referred to Committees at the Chicago City Council Meeting
10/21/2015

Section 3c - Aldermanic Introductions Regarding Unclassified Matters

File #	Title	Sponsor(s)	Committee Referral	
59	O2015-7779	Amendment of Municipal Code Chapter 2 by establishing new Chapter 2-174 entitled City of Chicago Equal Access Initiative	Moore (17) Villegas (36) Napolitano (41) Moreno (1) Foulkes (16) Curtis (18) Sawyer (6) Moore (49) Lopez (15) Cappleman (46) Pawar (47) Arena (45) Ramirez-Rosa (35) Silverstein (50) Mitchell (7) Zalewski (23) Munoz (22) Scott, Jr. (24) Mitts (37) Reilly (42) Sposato (38) Tunney (44)	Rules
60	O2015-7697	Amendment of Municipal Code Section 9-68-020 concerning residential parking permit placards for aldermen and aldermanic staff	Cochran (20)	Pedestrian and Traffic Safety
61	O2015-7755	Amendment of Municipal Code Section 9-64-205 by further regulating parking meters and hours of operation on portion of S Archer Ave, removal of meters on portion of W Taylor St and installation of meters on portion of S Canalport	Solis (25)	Pedestrian and Traffic Safety
62	O2015-7719	Amendment of Municipal Code Chapters 3-12 and 11-12 by establishment of stormwater stress user fee	Ramirez-Rosa (35) Waguespack (32) Sposato (38) Arena (45) Foulkes (16) Sadlowski Garza (10) Moore (17) Munoz (22) Sawyer (6) Hairston (5)	Finance

Legislation Referred to Committees at the Chicago City Council Meeting

10/21/2015

Section 3c - Aldermanic Introductions Regarding Unclassified Matters

File #	Title	Sponsor(s)	Committee Referral		
63	O2015-7693	Amendment of Municipal Code Chapters 3-46 and 9-115 by modifying tax imposed, licensing requirements and operating regulations for transportation network service drivers	Arena (45) Beale (9) Sposato (38) Munoz (22) Hairston (5) Sawyer (6) Cochran (20) Moore (17) Waguespack (32) Cappleman (46) Pawar (47) Silverstein (50) Lopez (15) Napolitano (41) Maldonado (26) Reboyras (30) Solis (25) Foulkes (16) Dowell (3) Ramirez-Rosa (35) Sadlowski Garza (10)	Finance	
64	O2015-7774	Amendment of Municipal Code Section 10-28-805 regarding minimum fee for sidewalk cafe permit	Arena (45) Foulkes (16) Sawyer (6) Sadlowski Garza (10) Hairston (5) Waguespack (32) Moore (17) Munoz (22) Ramirez-Rosa (35)	Joint Finance/License	<i>Redacted Record</i>
65	O2015-7776	Amendment of Municipal Code Section 4-156-020 concerning amusement tax imposed on admission to artistic or musical performances	Arena (45) Hairston (5) Sawyer (6) Sadlowski Garza (10) Foulkes (16) Moore (17) Munoz (22) Waguespack (32) Ramirez-Rosa (35) Napolitano (41) Maldonado (26)	Finance	
66	O2015-7777	Amendment of Municipal Code Section 4-156-020 concerning imposition of amusement tax for horse drawn carriages	Arena (45) Hairston (5) Sawyer (6) Sadlowski Garza (10) Foulkes (16) Moore (17) Munoz (22) Waguespack (32) Ramirez-Rosa (35) Maldonado (26)	Finance	

Legislation Referred to Committees at the Chicago City Council Meeting

10/21/2015

Section 3c - Aldermanic Introductions Regarding Unclassified Matters

File #	Title	Sponsor(s)	Committee Referral
Sign(s)/Signboard(s)			
67	Or2015-644	Issuance of permits for sign(s)/signboard(s) at 1433-1437 N Milwaukee Ave	Moreno (1) Zoning
68	Or2015-642	Issuance of permits for sign(s)/signboard(s) at 9928 S Western Ave	O'Shea (19) Zoning
69	Or2015-643	Issuance of permits for sign(s)/signboard(s) at 2335 S Western Ave	Solis (25) Zoning
70	Or2015-647	Issuance of permits for sign(s)/signboard(s) at 4710 N Kimball Ave	Mell (33) Zoning



City of Chicago



O2015-7694

Office of the City Clerk

Document Tracking Sheet

Meeting Date: 10/21/2015

Sponsor(s): Sadlowski Garza (10)

Type: Ordinance

Title: Amendment of Municipal Code Section 4-60-022 (10.162)
to allow additional alcoholic liquor licenses on portion(s) of E
135th St and S Baltimore Ave

Committee(s) Assignment: Committee on License and Consumer Protection

ORDINANCE

BE IT ORDAINED BY THE CITY COUNCIL OF THE CITY OF CHICAGO:

SECTION 1. Section 4-60-022 of the Municipal Code of Chicago is hereby amended by deleting the language struck through, as follows:

4-60-022 Restrictions on additional licenses.

Subject to the provisions of subsection 4-60-021(c), no additional license shall be issued for the sale of alcoholic liquor, for consumption on the premises within the following areas:

(Omitted text is unaffected by this ordinance)

~~(10.162) On 135th Street, from Burley Avenue to Baltimore Avenue; then on Baltimore Avenue from 135th Street, to Brainard Avenue.~~

(Omitted text is unaffected by this ordinance)

SECTION 2. This ordinance shall be in force and effect upon passage and approval.

Susan Sadlowksi-Garza
Alderman, 10th Ward



City of Chicago



O2015-7696

Office of the City Clerk

Document Tracking Sheet

Meeting Date:	10/21/2015
Sponsor(s):	Burke (14)
Type:	Ordinance
Title:	Amendment of Municipal Code Section 4-60-022 (23.9) to allow additional alcoholic liquor licenses on portion(s) of W Archer Ave
Committee(s) Assignment:	Committee on License and Consumer Protection

ORDINANCE

BE IT ORDAINED BY THE CITY COUNCIL OF THE CITY OF CHICAGO:

SECTION 1. Section 4-60-022 of the Municipal Code of Chicago is hereby amended by deleting the language struck through, as follows:

4-60-022 Restrictions on additional licenses.

Subject to the provisions of subsection 4-60-021(c), no additional license shall be issued for the sale of alcoholic liquor, for consumption on the premises within the following areas:

(Omitted text is unaffected by this ordinance)

4-60-022 (23.9) ~~On Archer Avenue, from Laramie Avenue to Long Avenue.~~

(Omitted text is unaffected by this ordinance)

SECTION 2. This ordinance shall be in force and effect upon passage and approval.

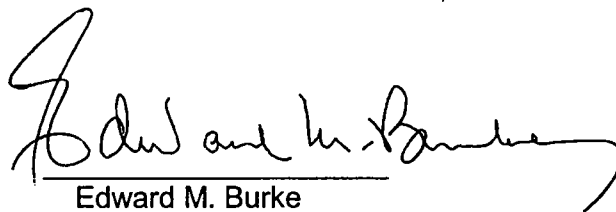

Edward M. Burke
Alderman, 14th Ward





City of Chicago



O2015-7698

Office of the City Clerk

Document Tracking Sheet

Meeting Date:	10/21/2015
Sponsor(s):	Burke (14)
Type:	Ordinance
Title:	Exemption from physical barrier requirement for commercial driveway alley access for Maribis of Chicago LLC
Committee(s) Assignment:	Committee on Transportation and Public Way

BE IT ORDAINED BY THE CITY COUNCIL OF THE CITY OF CHICAGO:

SECTION 1. SECTION 10-20-430 of the Municipal Code of Chicago, the Commissioner of Transportation is hereby authorized and directed to exempt Maribis of Chicago LLC at 4570 South Archer Ave.. from the provisions requiring barriers as a prerequisite to prohibit alley ingress and egress to parking facilities for Premise address.

SECTION 2. This ordinance shall take effect and be in force from and after its passage and publication.

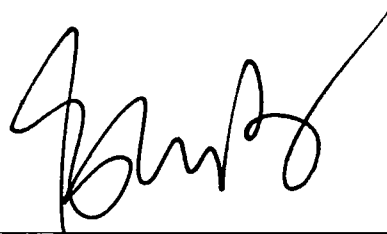
A handwritten signature in black ink, appearing to read 'E. M. Burke', is written above a horizontal line.

EDWARD M. BURKE
Alderman 14th Ward



City of Chicago



O2015-7688

Office of the City Clerk

Document Tracking Sheet

Meeting Date:	10/21/2015
Sponsor(s):	Maldonado (26)
Type:	Ordinance
Title:	Exemption from physical barrier requirement for commercial driveway alley access for Flexible Serv. & Construction, Inc. dba E&E Builders
Committee(s) Assignment:	Committee on Transportation and Public Way

BE IT ORDAINED BY THE CITY COUNCIL OF THE CITY OF CHICAGO:

SECTION 1. Section 10-20-430 of the Municipal Code of Chicago, the Commissioner of Transportation is hereby authorized and directed to exempt:

Property Owner: Leticia Kittaneh
Property Address: 3949 W. Armitage Ave.,Floor 1
Business Name: Flexible Serv. & Construction Inc DBA E&E Builders
Business Contact: Leticia Kittaneh
Phone Number: 773-430-6714

from the provisions requiring barriers as a prerequisite to prohibit alley ingress and egress to parking facilities for premise address: 3949 W. Armitage

SECTION 2. This ordinance shall take effect and be in force from and after its passage and publication.

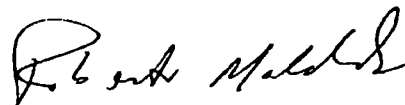

Roberto Maldonado
Alderman, 26th Ward



City of Chicago



O2015-7689

Office of the City Clerk

Document Tracking Sheet

Meeting Date:	10/21/2015
Sponsor(s):	Maldonado (26)
Type:	Ordinance
Title:	Exemption from physical barrier requirement for commercial driveway alley access for 1524-34 N Pulaski LLC
Committee(s) Assignment:	Committee on Transportation and Public Way

BE IT ORDAINED BY THE CITY COUNCIL OF THE CITY OF CHICAGO:

SECTION 1. Section 10-20-430 of the Municipal Code of Chicago, the Commissioner of Transportation is hereby authorized and directed to exempt:

Property Owner: 1524-34 N Pulaski, LLC
Property Address: 1524-34 N. Pulaski (10 apartments, 5 Stores)
Business Contact: Abraham Fattah
Phone Number: 773-616-6320

from the provisions requiring barriers as a prerequisite to prohibit alley ingress and egress to parking facilities for premise address: 1524-34 N. Pulaski

SECTION 2. This ordinance shall take effect and be in force from and after its passage and publication.

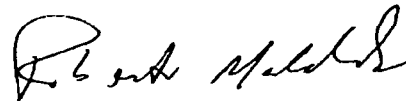

Roberto Maldonado
Alderman, 26th Ward



City of Chicago



O2015-7691

Office of the City Clerk

Document Tracking Sheet

Meeting Date:	10/21/2015
Sponsor(s):	O'Connor (40)
Type:	Ordinance
Title:	Exemption from physical barrier requirement for commercial driveway alley access for KMDM Properties
Committee(s) Assignment:	Committee on Transportation and Public Way

City Council Meeting
October 21, 2015
Transportation and Public Way

ORDINANCE

BE IT ORDAINED BY THE CITY COUNCIL OF THE CITY OF CHICAGO:

SECTION 1. Pursuant to Section 10-20-430 of the Municipal Code of Chicago, the Commissioner of Transportation is hereby authorized and directed to exempt **KMDM Properties, 5202 N. Oakley Avenue, Chicago, Illinois 60625** from the provisions requiring barriers as a prerequisite to prohibit alley ingress and egress to parking facilities for premise address.

SECTION 2. This ordinance shall take effect and be in force upon its passage and publication.

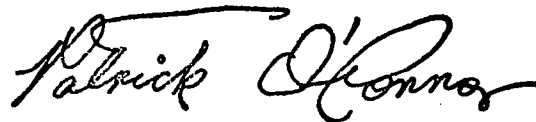

Patrick J. O'Connor - Alderman, 40th Ward



City of Chicago



O2015-7690

Office of the City Clerk Document Tracking Sheet

Meeting Date:	10/21/2015
Sponsor(s):	Cappleman (46)
Type:	Ordinance
Title:	Exemption from physical barrier requirement for commercial driveway alley access for Via Veneto Condominium Association
Committee(s) Assignment:	Committee on Transportation and Public Way

BE IT ORDAINED BY THE CITY OF CHICAGO

SECTION 1: Section 10-20-430 of the Municipal Code of Chicago, the Commissioner of Transportation is hereby authorized and directed to exempt the Via Veneto Condominium Association requiring barriers as a prerequisite to prohibit alley ingress and egress to parking facilities for premise address: 4636 N. Malden.

SECTION 2: This ordinance shall take effect and be in force from and after it's passage and publication.

A handwritten signature in black ink that reads "James Cappleman". The signature is written in a cursive style and is positioned above a horizontal line.

James Cappleman
Alderman, 46th Ward



City of Chicago



Or2015-648

Office of the City Clerk

Document Tracking Sheet

Meeting Date: 10/21/2015

Sponsor(s): Arena (45)
Hairston (5)
Sawyer (6)
Sadlowski Garza (10)
Foulkes (16)
Moore (17)
Waguespack (32)
Munoz (22)
Ramirez-Rosa (35)

Type: Order

Title: Commissioner of Business Affairs and Consumer Protection
ordered to update assessed land values utilized for setting
price of sidewalk cafe permits

Committee(s) Assignment: Committee on License and Consumer Protection

Committee on License and Consumer Protection
October 21, 2015
City Council Meeting

ORDER

ORDERED, That the Commissioner of Business Affairs and Consumer Protection (BACP) is authorized and directed to update the assessed land values currently utilized for setting the price of Sidewalk Café Permits under City of Chicago Municipal Code 10-28-800 et seq., to those of the 2015 assessment period and adjust Sidewalk Café Permit fees accordingly.

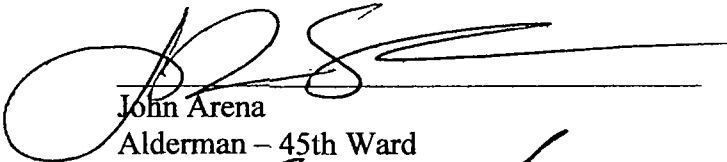

John Arena
Alderman - 45th Ward

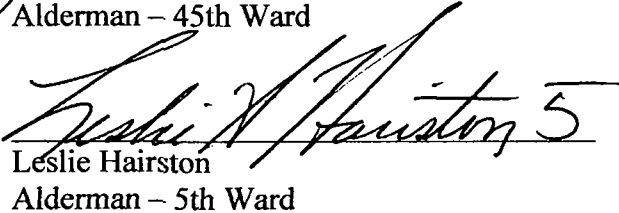

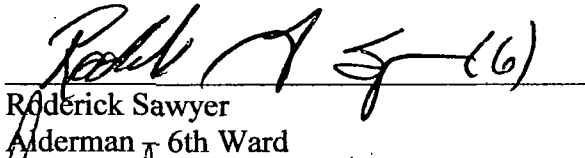

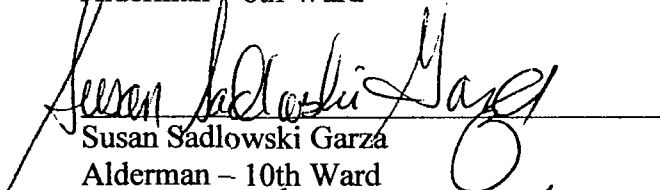
Leslie Hairston
Alderman - 5th Ward

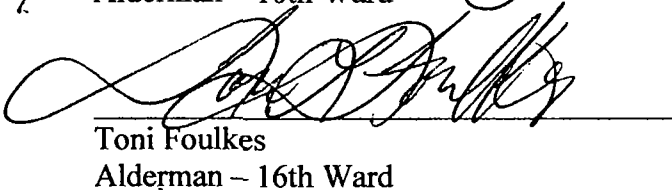
Roderick Sawyer
Alderman - 6th Ward

Susan Sadlowski Garza
Alderman - 10th Ward

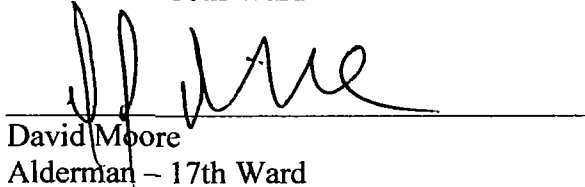
Toni Foulkes
Alderman - 16th Ward

David Moore
Alderman - 17th Ward

Ricardo Munoz

Ricardo Munoz
Alderman – 22nd Ward

Chris Taliaferro
Alderman – 29th Ward

Scott Waguespack
Alderman – 32nd Ward

Carlos Ramirez-Rosa 35

Carlos Ramirez-Rosa
Alderman – 35th Ward

Nicholas Sposato
Alderman – 38th Ward



City of Chicago



O2015-7732

Office of the City Clerk

Document Tracking Sheet

Meeting Date:	10/21/2015
Sponsor(s):	Burnett (27)
Type:	Ordinance
Title:	Awning(s) for Honey's
Committee(s) Assignment:	Committee on Transportation and Public Way

ORDINANCE
HONEY'S
Acct. No. 395877 - 1
Permit No. 1120392

Be It Ordained by the City Council of the City of Chicago:

SECTION 1. Permission and authority are hereby given and granted to HONEY'S, upon the terms and subject to the conditions of this ordinance to construct, install, maintain and use one (1) Awning(s) projecting over the public right-of-way adjacent to its premises known as 1111-1113 W. Lake St..

Said Awning(s) at W. Lake measure(s):

One (1) at six point three three (6.33) feet in length, and four point one seven (4.17) feet in width for a total of twenty-six point four (26.4) square feet.

The location of said privilege shall be as shown on prints kept on file with the Department of Business Affairs and Consumer Protection and the Office of the City Clerk.

Said privilege shall be constructed in accordance with plans and specifications approved by the Zoning Department - Signs.

This grant of privilege in the public way shall be subject to the provisions of Section 10-28-015 and all other required provisions of the Municipal Code of Chicago.

The grantee shall pay to the City of Chicago as compensation for the privilege #1120392 herein granted the sum of fifty (\$50.00) per annum in advance.

A 25% penalty will be added for payments received after due date.

The permit holder agrees to hold the City of Chicago harmless for any damage, relocation or replacement costs associated with damage, relocation or removal of private property caused by the City performing work in the public way.

Authority herein given and granted for a period of five (5) years from and after Date of Passage.

Alderman 
Walter Burnett Jr. 27th Ward



CURRENT VIEW OF PUBLIC WAY

Account #395877
1111 W LAKE STREET, LLC
d/b/a *Honey's*
1111-1113 W. Lake Street, Chicago, IL 60607



City of Chicago

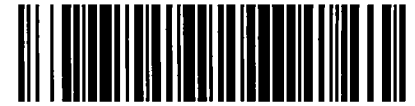

O2015-7729

Office of the City Clerk

Document Tracking Sheet

Meeting Date:	10/21/2015
Sponsor(s):	Mell (33)
Type:	Ordinance
Title:	Awning(s) for Good Shepherd Healthcare LLC
Committee(s) Assignment:	Committee on Transportation and Public Way

ORDINANCE

Good Shepherd Healthcare, LLC

Acct. No. 305325 - 1

Permit No. 1120398

Be It Ordained by the City Council of the City of Chicago:

SECTION 1. Permission and authority are hereby given and granted to Good Shepherd Healthcare, LLC, upon the terms and subject to the conditions of this ordinance to maintain and use, as now constructed, one (1) Awning(s) projecting over the public right-of-way adjacent to its premises known as 3144 W. Montrose Ave..

Said Awning(s) at W. MONTROSE measure(s):

One (1) at four (4) feet in length, and four (4) feet in width for a total of sixteen (16) square feet.

The location of said privilege shall be as shown on prints kept on file with the Department of Business Affairs and Consumer Protection and the Office of the City Clerk.

Said privilege shall be constructed in accordance with plans and specifications approved by the Zoning Department - Signs.

This grant of privilege in the public way shall be subject to the provisions of Section 10-28-015 and all other required provisions of the Municipal Code of Chicago.

The grantee shall pay to the City of Chicago as compensation for the privilege #1120398 herein granted the sum of fifty (\$50.00) per annum in advance.

A 25% penalty will be added for payments received after due date.

The permit holder agrees to hold the City of Chicago harmless for any damage, relocation or replacement costs associated with damage, relocation or removal of private property caused by the City performing work in the public way.

Authority herein given and granted for a period of five (5) years from and after 09/10/2013.

Alderman

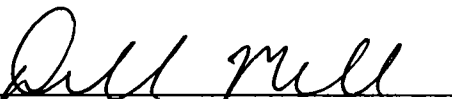

Deborah Mell 33rd Ward

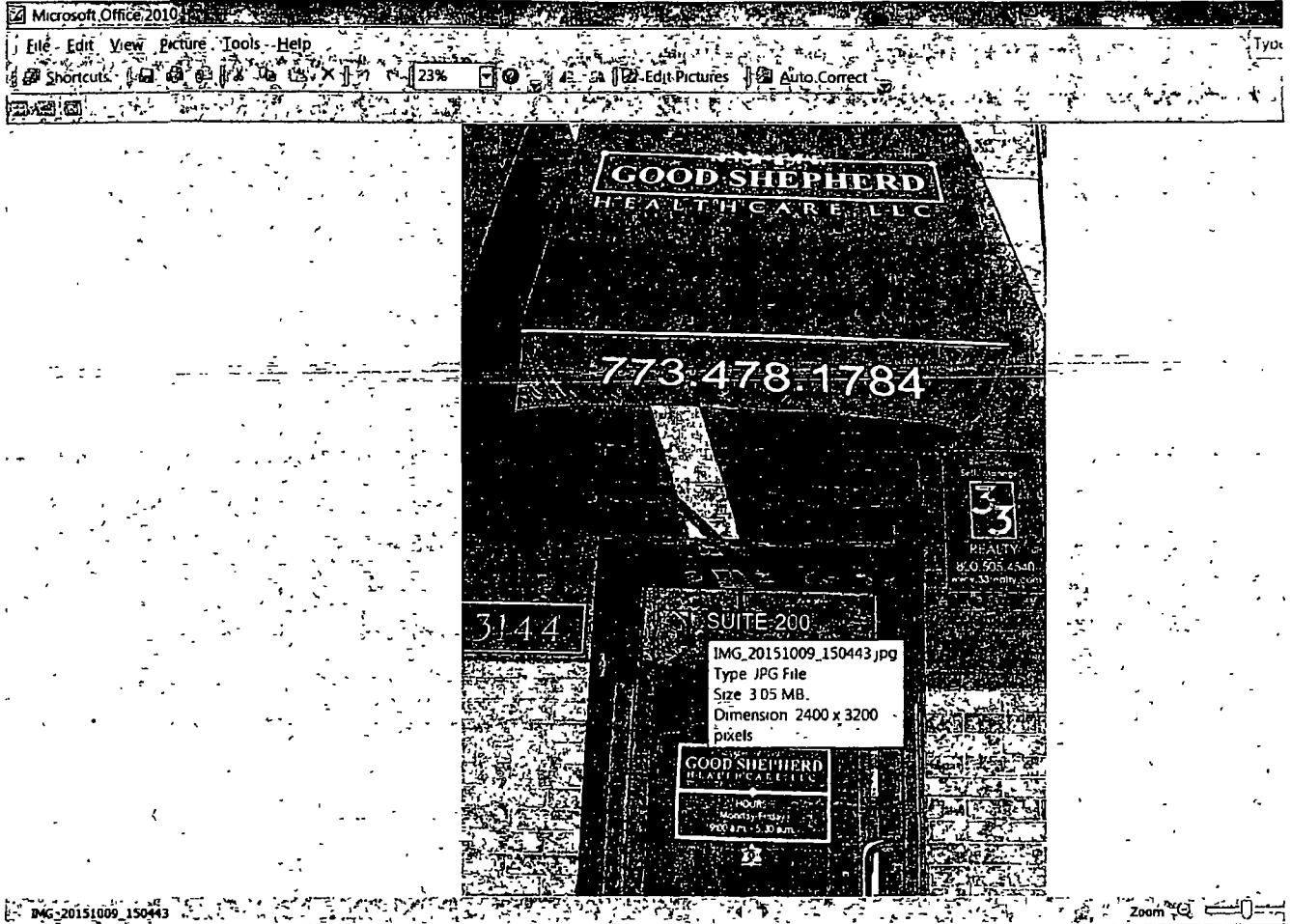



Department of Business Affairs and Consumer Protection
Small Business Center - Public Way Use Unit
City Hall - 121 N. LaSalle Street, Room 800 • Chicago, IL 60602
312-74-GOBIZ / 312-744-6249 • (312) 744-1944 (TTY)
<http://www.cityofchicago.org/bacp>

10/21/2015

Alderman Deborah Mell
Ward # 33
City of Chicago
City Hall, Room 200
121 North LaSalle Street
Chicago, Illinois 60602

Re: An ordinance to use and maintain a portion of the public right-of-way for **one (1) awning(s)** for **Good Shepherd Healthcare, LLC**, adjacent to the premises known as **3144 W. Montrose Ave.**.

Dear Alderman **Deborah Mell**:

The applicant referenced above has requested the use of the public right-of-way for a **awning(s)**. An ordinance has been prepared by the Department of Business Affairs and Consumer Protection – Small Business Center - Public Way Use Unit for presentation to the City Council. Because this request was made for properties located in your ward, as approved by you as per the attached, I respectfully request that you introduce the attached ordinance at the next City Council meeting.

If you have any questions regarding this ordinance, please contact Anthony Bertuca at (312) 744-5506.

Department of Business Affairs and Consumer Protection



City of Chicago



O2015-7739

Office of the City Clerk

Document Tracking Sheet

Meeting Date:	10/21/2015
Sponsor(s):	Lopez (15)
Type:	Ordinance
Title:	Canopy(s) for Walgreens No. 05356
Committee(s) Assignment:	Committee on Transportation and Public Way

ORDINANCE
Walgreens # 05356
Acct. No. 7551 - 73
Permit No. 1119464

Be It Ordained by the City Council of the City of Chicago:

SECTION 1. Permission and authority are hereby given and granted to Walgreens # 05356, upon the terms and subject to the conditions of this ordinance to maintain and use, as now constructed, five (5) Canopy(s) projecting over the public right-of-way adjacent to its premises known as 4710 S. Western Ave..

Said Canopy(s) at S. Western Avenue measure(s):

Five (5) at fourteen (14) feet in length, and three point four one (3.41) feet in width for a total of two hundred thirty-eight point seven (238.7) square feet.

The location of said privilege shall be as shown on prints kept on file with the Department of Business Affairs and Consumer Protection and the Office of the City Clerk.

Said privilege shall be constructed in accordance with plans and specifications approved by the Zoning Department - Signs.

This grant of privilege in the public way shall be subject to the provisions of Section 10-28-015 and all other required provisions of the Municipal Code of Chicago.

The grantee shall pay to the City of Chicago as compensation for the privilege #1119464 herein granted the sum of one hundred seventy-five (\$175.00) per annum in advance.

A 25% penalty will be added for payments received after due date.

The permit holder agrees to hold the City of Chicago harmless for any damage, relocation or replacement costs associated with damage, relocation or removal of private property caused by the City performing work in the public way.

Authority herein given and granted for a period of five (5) years from and after 01/13/2014.

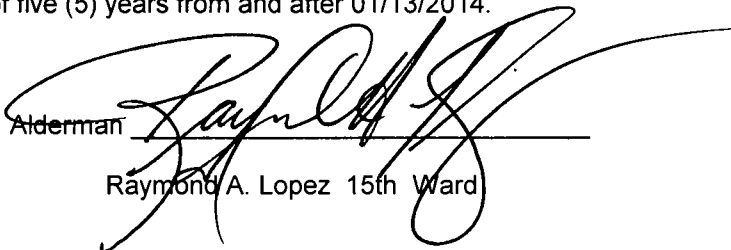
Alderman 
Raymond A. Lopez 15th Ward

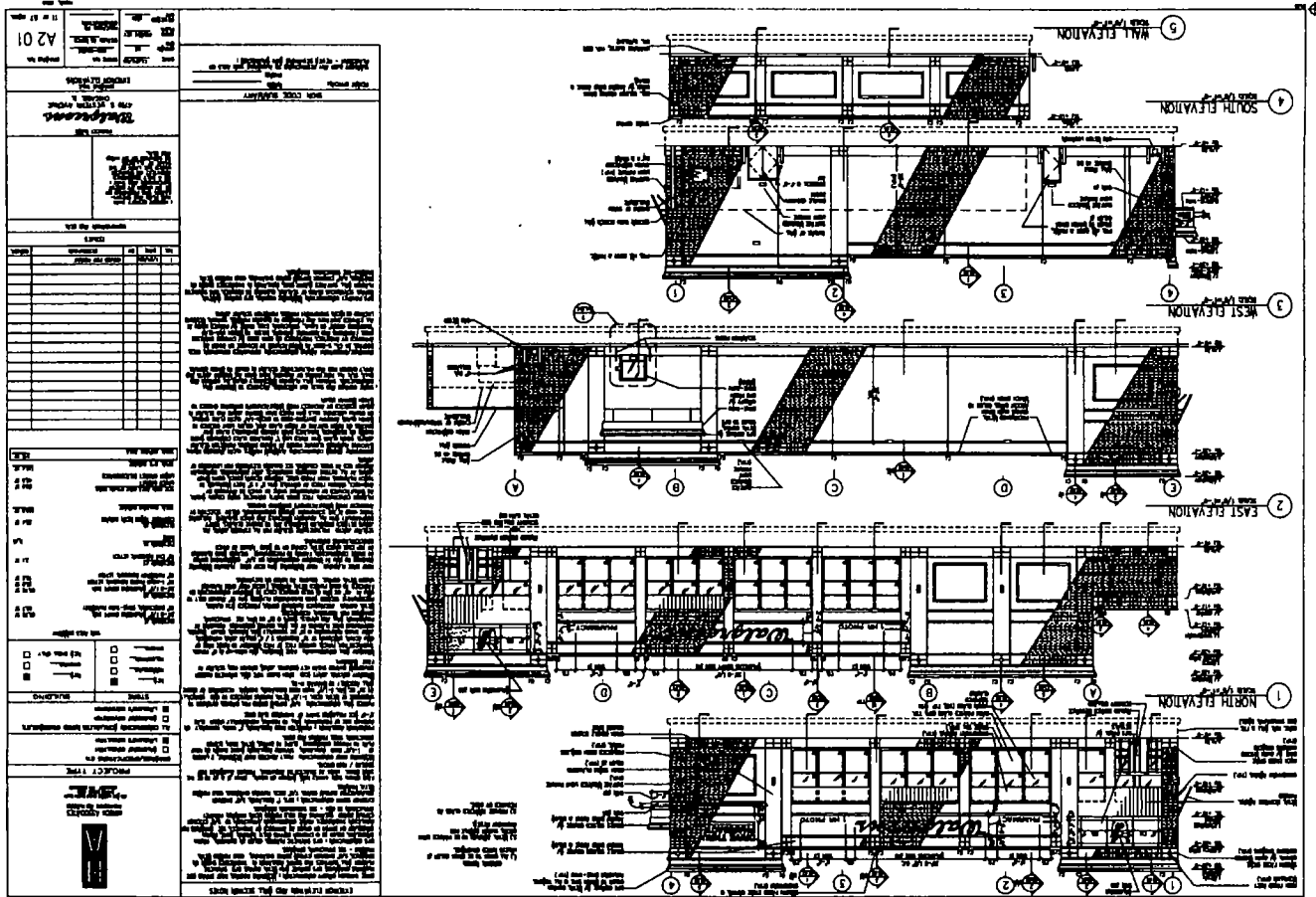



2nd ATTEMPT AT INTRODUCTION

10/21/2015

Alderman **Raymond A. Lopez**
Ward # 15
City of Chicago
City Hall, Room 300
121 North LaSalle Street
Chicago, Illinois 60602

Re: An ordinance to use and maintain a portion of the public right-of-way for **five (5) canopy(ies)** for **Walgreens # 05356**, adjacent to the premises known as **4710 S. Western Ave.**.

Dear Alderman **Raymond A. Lopez**:

The applicant referenced above has requested the use of the public right-of-way for a **canopy(ies)**. An ordinance has been prepared by the Department of Business Affairs and Consumer Protection – Small Business Center - Public Way Use Unit for presentation to the City Council. Because this request was made for properties located in your ward, as approved by you as per the attached, I respectfully request that you introduce the attached ordinance at the next City Council meeting.

If you have any questions regarding this ordinance, please contact Anthony Bertuca at (312) 744-5506.

Department of Business Affairs and Consumer Protection



City of Chicago



O2015-7740

Office of the City Clerk

Document Tracking Sheet

Meeting Date:	10/21/2015
Sponsor(s):	Villegas (36)
Type:	Ordinance
Title:	Canopy(s) for Paola's Hair Salon
Committee(s) Assignment:	Committee on Transportation and Public Way

ORDINANCE
PAOLA'S HAIR SALON
Acct. No. 397266 - 1
Permit No. 1118086

Be It Ordained by the City Council of the City of Chicago:

SECTION 1. Permission and authority are hereby given and granted to PAOLA'S HAIR SALON, upon the terms and subject to the conditions of this ordinance to maintain and use, as now constructed, one (1) Canopy(s) projecting over the public right-of-way adjacent to its premises known as 6956 W. Diversey Ave..

Said Canopy(s) at W. Deversey Avenue measure(s):

One (1) at twenty-three (23) feet in length, and two (2) feet in width for a total of forty-six (46) square feet.

The location of said privilege shall be as shown on prints kept on file with the Department of Business Affairs and Consumer Protection and the Office of the City Clerk.

Said privilege shall be constructed in accordance with plans and specifications approved by the Zoning Department - Signs.

This grant of privilege in the public way shall be subject to the provisions of Section 10-28-015 and all other required provisions of the Municipal Code of Chicago.

The grantee shall pay to the City of Chicago as compensation for the privilege #1118086 herein granted the sum of fifty (\$50.00) per annum in advance.

A 25% penalty will be added for payments received after due date.

The permit holder agrees to hold the City of Chicago harmless for any damage, relocation or replacement costs associated with damage, relocation or removal of private property caused by the City performing work in the public way.

Authority herein given and granted for a period of five (5) years from and after Date of Passage.

Alderman

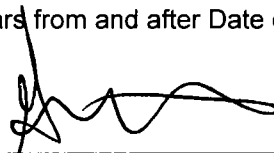

Gilbert Villegas 36th Ward

#100595270

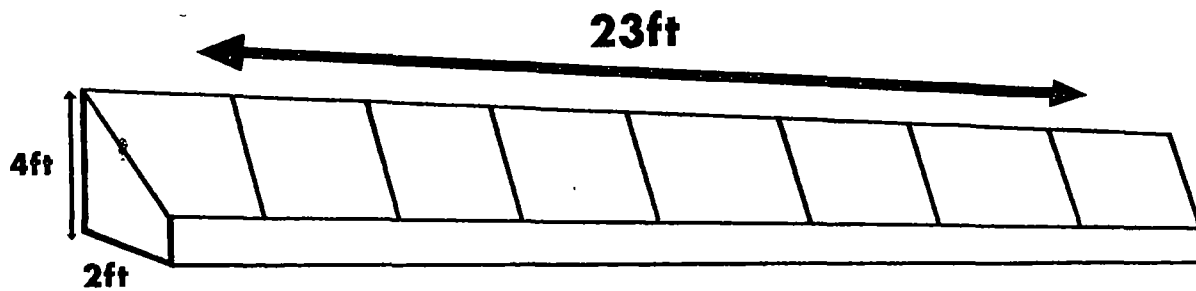

3" 5/8" metal screws

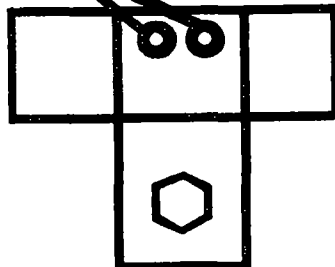
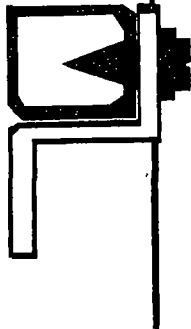

1"x1" Galvanized Steel Tubing 16GA. typ

Z clamp brackets 1"x1" screws 3/16 3" latches 5/18

Fabric on awning will be in sunbrella color black and white lettering.

1/2" RND. Gal. Stl Tubing middle of awning for support

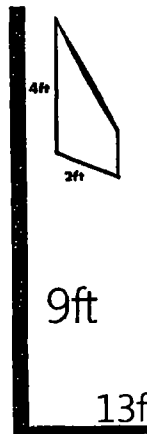

frame to wall anchor



2nd ATTEMPT AT INTRODUCTION

10/21/2015

Alderman **Gilbert Villegas**
Ward # **36**
City of Chicago
City Hall, Room **200**
121 North LaSalle Street
Chicago, Illinois 60602

Re: An ordinance to use and maintain a portion of the public right-of-way for **one (1) canopy(ies)** for **PAOLA'S HAIR SALON**, adjacent to the premises known as **6956 W. Diversey Ave.**.

Dear Alderman **Gilbert Villegas**:

The applicant referenced above has requested the use of the public right-of-way for a **canopy(ies)**. An ordinance has been prepared by the Department of Business Affairs and Consumer Protection – Small Business Center - Public Way Use Unit for presentation to the City Council. Because this request was made for properties located in your ward, as approved by you as per the attached, I respectfully request that you introduce the attached ordinance at the next City Council meeting.

If you have any questions regarding this ordinance, please contact Anthony Bertuca at (312) 744-5506.

Department of Business Affairs and Consumer Protection



City of Chicago



R2015-829

Office of the City Clerk

Document Tracking Sheet

Meeting Date:

10/21/2015

Sponsor(s):

Villegas (36)
O'Shea (19)
Ramirez-Rosa (35)
Waguespack (32)
Cochran (20)
Sposato (38)
Reboyas (30)
Taliaferro (29)
Moreno (1)
Maldonado (26)
Laurino (39)
Solis (25)
Scott, Jr. (24)
Mitts (37)
Munoz (22)
Quinn (13)
Foulkes (16)
Moore (17)
Curtis (18)
Zalewski (23)
Lopez (15)

Type:

Resolution

Title:

Call for Congress and Illinois General Assembly to take action to ensure railroads are sufficiently regulated

Committee(s) Assignment:

Committee on Health and Environmental Protection

~~Transportation~~ Committee
Health and Environment

RESOLUTION

WHEREAS, Unsafe, unattractive and bothersome conditions on railroad property are a continuing source of frustration for Chicago residents and for their aldermen, who on a daily basis field many complaints from residents upset by overgrown vegetation on railroad property, unreasonably long obstructions of crossings at grade, delayed access to emergency services at such crossings, excessive train idling, diesel fuel emissions and other problems; and

WHEREAS, Chicago is the most important railroad center in North America. More lines of track radiate in more directions from Chicago than from any other city in the United States. Chicago is the hub of our Nation's freight network, and ranks second only to New York City with respect to the volume of commuter rail passengers carried each day. Rail lines cross roadways at numerous points in Chicago, and are an integral and visible part of our communities; and

WHEREAS, Due to the number, type and scope of various Federal and State preemptions that restrict the ability of local municipalities to regulate rail carriers by ordinance, Chicagoans are at the mercy of railroad companies, and the Federal and State administrative bodies charged with responsibility for overseeing them, to ensure that railroad property is properly maintained; that railroad crossings do not block vehicular and pedestrian traffic for unreasonably long periods of time; that locomotives spend as little time as possible idling; and that the noise produced by trains does not constantly disrupt the peace and tranquility of surrounding neighborhoods; and

WHEREAS, At the Federal level, rail carriers are governed by several statutes, the bulk of which are administered by the U.S. Secretary of Transportation through various regulatory bodies, including the Federal Railroad Safety Act, administered through the Federal Railroad Administration; Hazardous Material Transportation Act (HMTA), administered through the Pipeline and Hazardous Material Safety Administration (PHMSA); Railroad Revitalization and Regulatory Reform Act and Rail Passenger Service Act, to name but a few. The Interstate Commerce Commission Termination Act, administered through the Surface Transportation Board, provides broad and extensive regulation of the activities of freight railroads operating in interstate commerce. In addition, because locomotives spend a substantial amount of time idling, the United States Environmental Protection Agency regulates diesel line-haul and passenger and switch locomotives, with a view toward reducing the time during which locomotives emit harmful pollutants, consume fuel and make noise; and

WHEREAS, In Illinois, the Illinois Commercial Transportation Law gives the Illinois Commerce Commission "exclusive power" to regulate rail carriers in Illinois and "all intrastate and interstate rail carrier operations within this State, except to the extent that its jurisdiction is preempted by . . . valid federal statute, regulation or order"; and

WHEREAS, Because this complex web of Federal and State preemptions makes it virtually impossible for the City of Chicago to regulate railroads in any meaningful way, it is incumbent upon Federal and State authorities to actively monitor the activities of railroads, in light of the very real needs and concerns of local residents, to ensure that the railroads are in compliance with all applicable laws, and to routinely undertake a systematic review of existing laws for the purpose of determining whether, in various areas, those laws should be modified to hold railroads to a higher standard of accountability to local residents than is currently the case; and

WHEREAS, There is no good reason why railroad property should be allowed to deteriorate to the point of blighting entire neighborhoods. Large weeds, frequently in excess of 15 inches in height, rusted and broken fencing, damaged lighting, graffiti and garbage strewn railroad viaducts, and inadequate rodent control on railroad property are commonplace. The urban landscape is being ruined and average citizens are suffering from an inability to enjoy life in their own homes and neighborhoods. Shielded by laws containing exceptionally broad preemptions covering every conceivable subject matter, railroads have no incentive whatsoever to address the legitimate concerns of local residents and, as a result, have become increasingly arrogant and unwilling to work with local governmental leaders to help solve the simplest of problems; and

WHEREAS, Our citizens deserve better. These conditions are unacceptable and should not be tolerated by the governmental entities charged with railroad oversight. An economically viable national railroad system should not come completely at the expense of quality of life in our Nation's communities; now, therefore,

BE IT RESOLVED, That we, the Mayor and Members of the City Council of the City of Chicago, assembled this fourteenth day of October, 2015, do hereby urge Congress and the Illinois General Assembly to take appropriate action to ensure that railroads are sufficiently regulated or otherwise incentivized, including through the vigorous application of monetary penalties, to ameliorate nuisance conditions on their property and in connection with railroad operations; and

BE IT FURTHER RESOLVED, That the City Clerk be directed to provide suitable copies of this resolution to the President pro tempore of the Senate and Speaker of the House of Representatives of the Congress of the United States, to each member of the Illinois congressional delegation, to the U.S. Secretary of Transportation; and to the Chairman of the Illinois Commerce Commission, as a sign of our concern for this important issue.

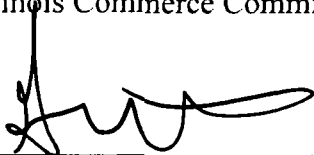

Alderman Gilbert Villegas, 36th Ward

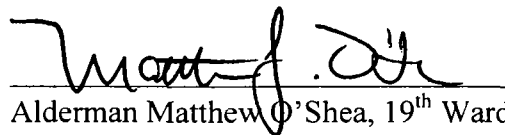

Alderman Matthew P. Shea, 19th Ward

Carlton Ramsey - Tom 35

W. M. J. Ford

Scott Dagnaspeal 32

Q 30

C. L. T. 29

Joe M. 27

Robert 26

W. J. 39

W. J. 25

W. J. 24

Jenna Mills 37

Delia 20

Michael 38#

Monte June 13
K. H. Walker 16
C. H. Walker 18
Walker 23

Walker 23



City of Chicago

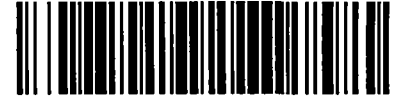

O2015-7711

Office of the City Clerk

Document Tracking Sheet

Meeting Date:	10/21/2015
Sponsor(s):	Moreno (1)
Type:	Ordinance
Title:	Grant(s) of privilege in public way for Cheesie's Pub & Grub
Committee(s) Assignment:	Committee on Transportation and Public Way

ORDINANCE
CHEESIE'S PUB & GRUB
Acct. No. 388148 - 1
Permit No. 1119391

Be It Ordained by the City Council of the City of Chicago:

SECTION 1. Permission and authority are hereby given and granted to CHEESIE'S PUB & GRUB, upon the terms and subject to the conditions of this ordinance to maintain and use one (1) sign(s) projecting over the public right-of-way attached to its premises known as 1365 N. Milwaukee Ave..

Said sign structure(s) measures as follows; along N MILWAUKEE AVE:

One (1) at fifteen point five (15.5) feet in length, one point six seven (1.67) feet in height and fifteen (15) feet above grade level.

The location of said privilege shall be as shown on prints kept on file with the Department of Business Affairs and Consumer Protection and the Office of the City Clerk.

Said privilege shall be constructed in accordance with plans and specifications approved by the Department of Transportation (Division of Project Development) and Zoning Department - Signs.

This grant of privilege in the public way shall be subject to the provisions of Section 10-28-015 and all other required provisions of the Municipal Code of Chicago.

The grantee shall pay to the City of Chicago as compensation for the privilege #1119391 herein granted the sum of three hundred (\$300.00) per annum in advance.

A 25% penalty will be added for payments received after due date.

The permit holder agrees to hold the City of Chicago harmless for any damage, relocation or replacement costs associated with damage, relocation or removal of private property caused by the City performing work in the public way.

Authority herein given and granted for a period of five (5) years from and after Date of Passage.

Alderman _____

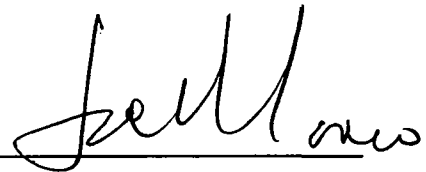

Proco Joe Moreno 1st Ward

PAGE: 1 of 3

COMPANY: Cheesie's Pub
REFERENCE
DATE May 20, 2015
ACCOUNT REP Todd K
FILE NAME Cheesie's Logo
DESIGNER Jasmine
REVISION #1

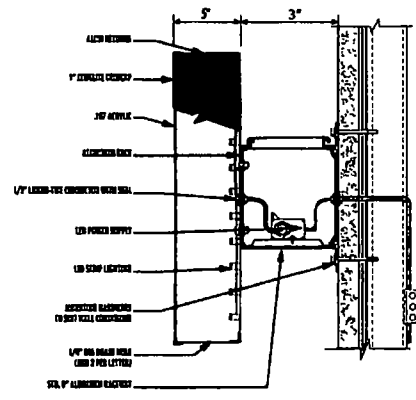
20" |  **CHEESIE'S PUB & GRUB** | 15'-6"



STD. LED ILLUMINATED CHANNEL LETTERS ON RACEWAY

15' 6" wide x 20" high overall front lit channel letters sign mounted on raceway to match brick color
 Sandwich image is 20" high x 23" wide
 Cheesie's copy 160" wide x 17" high overall, cap height is approx. 14%



AUTHORIZED SIGNATURE & DATE
 The person, specification, and equipment as described are satisfactory and are hereby accepted by signing below your authorized signature. The Alphabet Shop, Inc. will do the work as specified.
 Signature: _____ Date: _____
 This is an original drawing created by The Alphabet Shop, Inc. for a project being planned for you. This drawing is not to be reproduced, modified or transmitted to others for any purpose not authorized by The Alphabet Shop, Inc.



2nd ATTEMPT AT INTRODUCTION

10/21/2015

Alderman Proco Joe Moreno
Ward # 01
City of Chicago
City Hall, Room 300
121 North LaSalle Street
Chicago, Illinois 60602

Re: An ordinance to use and maintain a portion of the public right-of-way for **one (1) sign(s)** for **CHEESIE'S PUB & GRUB**, adjacent to the premises known as **1365 N. Milwaukee Ave.**.

Dear Alderman Proco Joe Moreno:

The applicant referenced above has requested the use of the public right-of-way for a **sign(s)**. An ordinance has been prepared by the Department of Business Affairs and Consumer Protection – Small Business Center - Public Way Use Unit for presentation to the City Council. Because this request was made for properties located in your ward, as approved by you as per the attached, I respectfully request that you introduce the attached ordinance at the next City Council meeting.

If you have any questions regarding this ordinance, please contact Anthony Bertuca at (312) 744-5506.

Department of Business Affairs and Consumer Protection



City of Chicago



O2015-7714

Office of the City Clerk

Document Tracking Sheet

Meeting Date:	10/21/2015
Sponsor(s):	Moreno (1)
Type:	Ordinance
Title:	Grant(s) of privilege in public way for Whiskey Business
Committee(s) Assignment:	Committee on Transportation and Public Way

ORDINANCE
WHISKEY BUSINESS
Acct. No. 388143 - 1
Permit No. 1119389

Be It Ordained by the City Council of the City of Chicago:

SECTION 1. Permission and authority are hereby given and granted to WHISKEY BUSINESS, upon the terms and subject to the conditions of this ordinance to maintain and use one (1) sign(s) projecting over the public right-of-way attached to its premises known as 1367 N. Milwaukee Ave..

Said sign structure(s) measures as follows; along N Milwaukee Ave:

One (1) at thirteen point three four (13.34) feet in length, three point four two (3.42) feet in height and fourteen (14) feet above grade level.

The location of said privilege shall be as shown on prints kept on file with the Department of Business Affairs and Consumer Protection and the Office of the City Clerk.

Said privilege shall be constructed in accordance with plans and specifications approved by the Department of Transportation (Division of Project Development) and Zoning Department - Signs.

This grant of privilege in the public way shall be subject to the provisions of Section 10-28-015 and all other required provisions of the Municipal Code of Chicago.

The grantee shall pay to the City of Chicago as compensation for the privilege #1119389 herein granted the sum of three hundred (\$300.00) per annum in advance.

A 25% penalty will be added for payments received after due date.

The permit holder agrees to hold the City of Chicago harmless for any damage, relocation or replacement costs associated with damage, relocation or removal of private property caused by the City performing work in the public way.

Authority herein given and granted for a period of five (5) years from and after Date of Passage.

Alderman

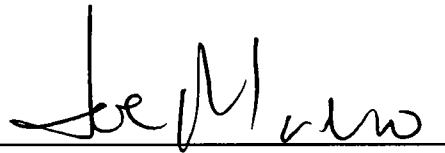

Proco Joe Moreno 1st Ward



COMPANY
Cheesie's Pub

REFERENCE

DATE
May 20, 2015

ACCOUNT REP.
Todd K

FILE NAME
Cheesie's Logo

DESIGNER
Jasmine

REVISION #1

AUTHORIZED SIGNATURE & DATE

The prices, specifications, and conditions as described are satisfactory and are hereby accepted by signing below you authorize The Alphabet Shop, Inc. to do the work as specified.

Signature

Date

This is an original drawing created by The Alphabet Shop, Inc. for a project being submitted for you. This drawing is not to be reproduced, altered or transmitted to others for any purpose not authorized by The Alphabet Shop, Inc.





2nd ATTEMPT AT INTRODUCTION

10/21/2015

Alderman **Proco Joe Moreno**
Ward # 01
City of Chicago
City Hall, Room 300
121 North LaSalle Street
Chicago, Illinois 60602

Re: An ordinance to use and maintain a portion of the public right-of-way for **one (1) sign(s)** for **WHISKEY BUSINESS**, adjacent to the premises known as **1367 N. Milwaukee Ave.**.

Dear Alderman **Proco Joe Moreno**:

The applicant referenced above has requested the use of the public right-of-way for a **sign(s)**. An ordinance has been prepared by the Department of Business Affairs and Consumer Protection – Small Business Center - Public Way Use Unit for presentation to the City Council. Because this request was made for properties located in your ward, as approved by you as per the attached, I respectfully request that you introduce the attached ordinance at the next City Council meeting.

If you have any questions regarding this ordinance, please contact Anthony Bertuca at (312) 744-5506.

Department of Business Affairs and Consumer Protection



City of Chicago



O2015-7717

Office of the City Clerk

Document Tracking Sheet

Meeting Date:	10/21/2015
Sponsor(s):	Hopkins (2)
Type:	Ordinance
Title:	Grant(s) of privilege in public way for Northwestern Memorial Hospital - catch basins
Committee(s) Assignment:	Committee on Transportation and Public Way

ORDINANCE
NORTHWESTERN MEMORIAL HOSPITAL
Acct. No. 69273 - 3
Permit No. 1120327

Be It Ordained by the City Council of the City of Chicago:

SECTION 1. Permission and authority are hereby given and granted to NORTHWESTERN MEMORIAL HOSPITAL, upon the terms and subject to the conditions of this ordinance to maintain and use, as now constructed, four (4) Catch Basin(s) under the public right-of-way adjacent to its premises known as 245 E. Chicago Ave..

Said Catch Basin(s) at E. SUPERIOR measure(s):

One (1) at five (5) feet in length, and five (5) feet in width for a total of twenty-five (25) square feet.

Said Catch Basin(s) at E. SUPERIOR measure(s):

One (1) at five (5) feet in length, and five (5) feet in width for a total of twenty-five (25) square feet.

Said Catch Basin(s) at N. FAIRBANKS measure(s):

One (1) at five (5) feet in length, and five (5) feet in width for a total of twenty-five (25) square feet.

Said Catch Basin(s) at E. CHICAGO measure(s):

One (1) at five (5) feet in length, and five (5) feet in width for a total of twenty-five (25) square feet.

The location of said privilege shall be as shown on prints kept on file with the Department of Business Affairs and Consumer Protection and the Office of the City Clerk.

Said privilege shall be constructed in accordance with plans and specifications approved by the Department of Transportation (Office of Underground Coordination) and Department of Water Management.

This grant of privilege in the public way shall be subject to the provisions of Section 10-28-015 and all other required provisions of the Municipal Code of Chicago.

The grantee shall pay to the City of Chicago as compensation for the privilege #1120327 herein granted the sum of one thousand six hundred (\$1,600.00) per annum in advance.

A 25% penalty will be added for payments received after due date.

The permit holder agrees to hold the City of Chicago harmless for any damage, relocation or replacement costs associated with damage, relocation or removal of private property caused by the City performing work in the public way.

Authority herein given and granted for a period of five (5) years from and after 10/06/2015.

Alderman



Brian Hopkins 2nd Ward

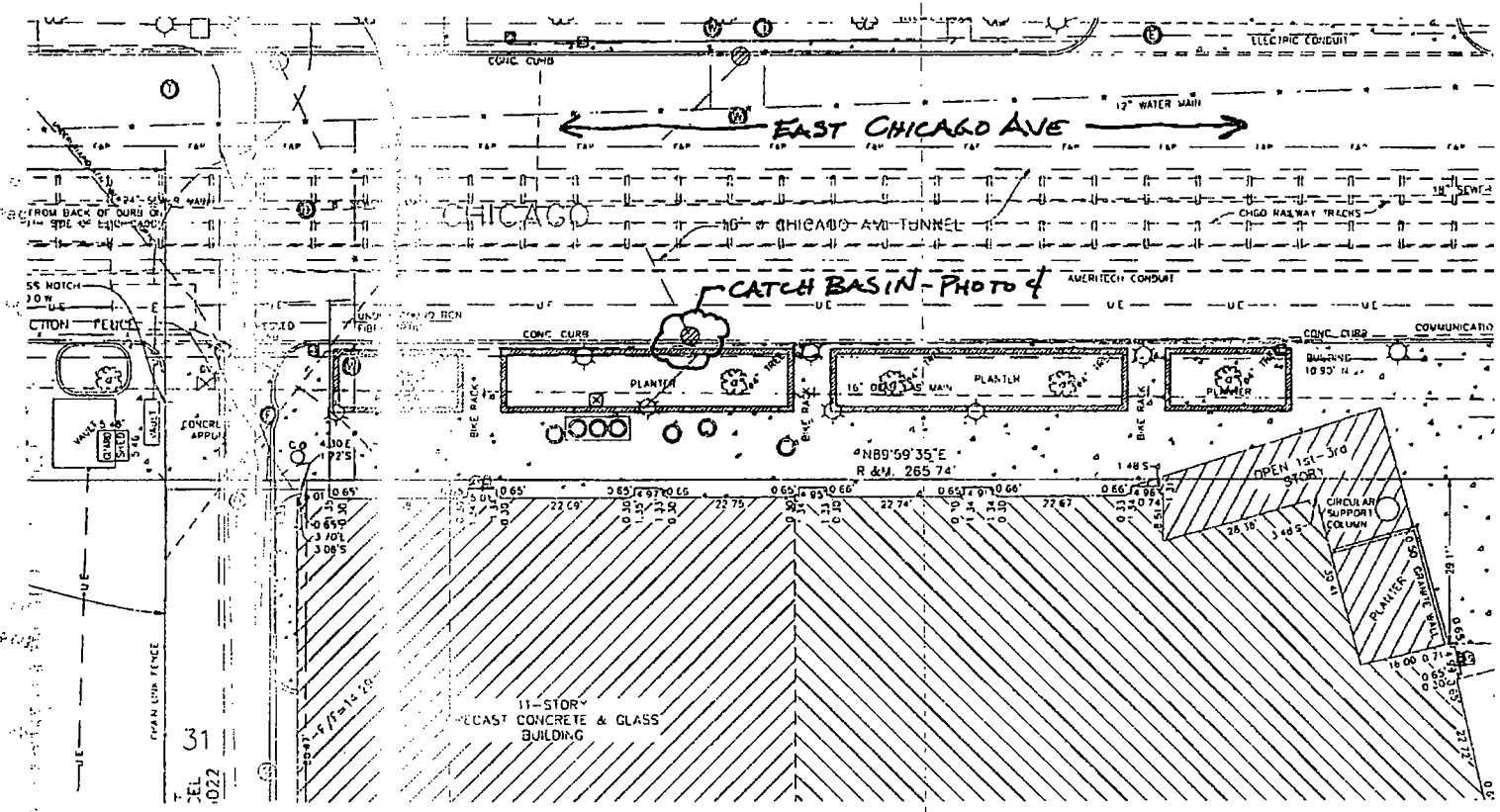

PARTIAL SITE PLAN 
CATCH BASIN
E. CHICAGO AVE



10/21/2015

Alderman **Brian Hopkins**
Ward # **02**
City of Chicago
City Hall, Room **200**
121 North LaSalle Street
Chicago, Illinois 60602

Re: An ordinance to use and maintain a portion of the public right-of-way for **four (4) catch basin(s)** for **NORTHWESTERN MEMORIAL HOSPITAL**, adjacent to the premises known as **245 E. Chicago Ave.**.

Dear Alderman **Brian Hopkins**:

The applicant referenced above has requested the use of the public right-of-way for a **catch basin(s)**. An ordinance has been prepared by the Department of Business Affairs and Consumer Protection – Small Business Center - Public Way Use Unit for presentation to the City Council. Because this request was made for properties located in your ward, as approved by you as per the attached, I respectfully request that you introduce the attached ordinance at the next City Council meeting.

If you have any questions regarding this ordinance, please contact Anthony Bertuca at (312) 744-5506.

Department of Business Affairs and Consumer Protection



City of Chicago



O2015-7721

Office of the City Clerk

Document Tracking Sheet

Meeting Date:	10/21/2015
Sponsor(s):	Hopkins (2)
Type:	Ordinance
Title:	Grant(s) of privilege in public way for Northwestern Memorial Hospital - grease trap
Committee(s) Assignment:	Committee on Transportation and Public Way

ORDINANCE
NORTHWESTERN MEMORIAL HOSPITAL
Acct. No. 69273 - 3
Permit No. 1120342

Be It Ordained by the City Council of the City of Chicago:

SECTION 1. Permission and authority are hereby given and granted to NORTHWESTERN MEMORIAL HOSPITAL, upon the terms and subject to the conditions of this ordinance to maintain and use, as now constructed, one (1) Grease Trap(s) under the public right-of-way adjacent to its premises known as 245 E. Chicago Ave..

Said Grease Trap(s) at E. CHICAGO measure(s):

One (1) at ten (10) feet in length, and five (5) feet in width for a total of fifty (50) square feet.

The location of said privilege shall be as shown on prints kept on file with the Department of Business Affairs and Consumer Protection and the Office of the City Clerk.

Said privilege shall be constructed in accordance with plans and specifications approved by the Department of Transportation (Office of Underground Coordination) and Department of Water Management.

This grant of privilege in the public way shall be subject to the provisions of Section 10-28-015 and all other required provisions of the Municipal Code of Chicago.

The grantee shall pay to the City of Chicago as compensation for the privilege #1120342 herein granted the sum of four hundred (\$400.00) per annum in advance.

A 25% penalty will be added for payments received after due date.

The permit holder agrees to hold the City of Chicago harmless for any damage, relocation or replacement costs associated with damage, relocation or removal of private property caused by the City performing work in the public way.

Authority herein given and granted for a period of five (5) years from and after 10/06/2015.

Alderman *Brian Hopkins*

Brian Hopkins 2nd Ward

← E. CHICAGO AVENUE →

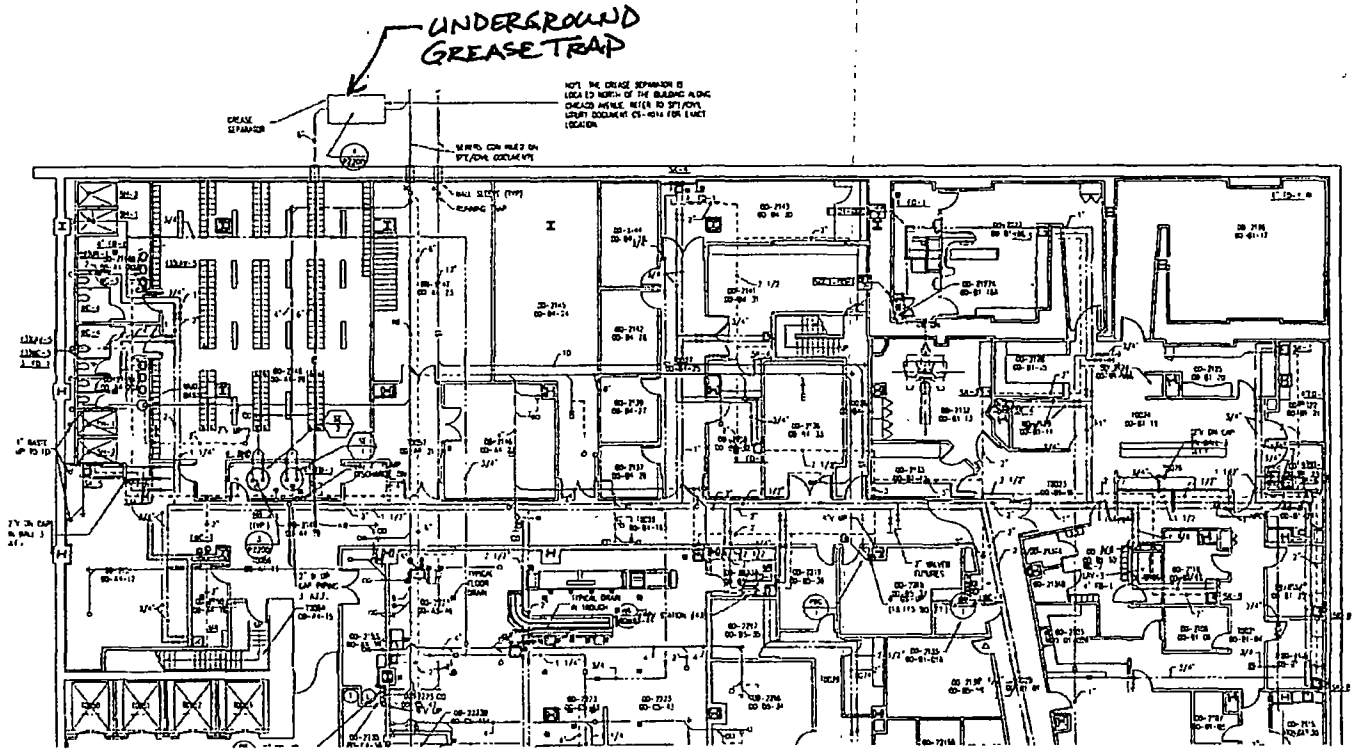

PARTIAL UNDERGROUND
PLUMBING PLAN
GREASE TRAP
69273-3 PWD 1094076





Department of Business Affairs and Consumer Protection

Small Business Center - Public Way Use Unit

City Hall - 121 N. LaSalle Street, Room 800 • Chicago, IL 60602

312-74-GOBIZ / 312-744-6249 • (312) 744-1944 (TTY)

<http://www.cityofchicago.org/bacp>

10/21/2015

Alderman **Brian Hopkins**

Ward # **02**

City of Chicago

City Hall, Room **200**

121 North LaSalle Street

Chicago, Illinois 60602

Re: An ordinance to use and maintain a portion of the public right-of-way for **one (1) grease trap(s)** for **NORTHWESTERN MEMORIAL HOSPITAL**, adjacent to the premises known as **245 E. Chicago Ave.**.

Dear Alderman **Brian Hopkins**:

The applicant referenced above has requested the use of the public right-of-way for a **grease trap(s)**. An ordinance has been prepared by the Department of Business Affairs and Consumer Protection – Small Business Center - Public Way Use Unit for presentation to the City Council. Because this request was made for properties located in your ward, as approved by you as per the attached, I respectfully request that you introduce the attached ordinance at the next City Council meeting.

If you have any questions regarding this ordinance, please contact Anthony Bertuca at (312) 744-5506.

Department of Business Affairs and Consumer Protection



City of Chicago



O2015-7724

Office of the City Clerk

Document Tracking Sheet

Meeting Date:	10/21/2015
Sponsor(s):	Hopkins (2)
Type:	Ordinance
Title:	Grant(s) of privilege in public way for Northwestern Memorial Hospital - manhole
Committee(s) Assignment:	Committee on Transportation and Public Way

ORDINANCE
NORTHWESTERN MEMORIAL HOSPITAL
Acct. No. 69273 - 3
Permit No. 1120336

Be It Ordained by the City Council of the City of Chicago:

SECTION 1. Permission and authority are hereby given and granted to NORTHWESTERN MEMORIAL HOSPITAL, upon the terms and subject to the conditions of this ordinance to maintain and use, as now constructed, one (1) Manhole(s) under the public right-of-way adjacent to its premises known as 245 E. Chicago Ave..

Said Manhole(s) at E. CHICAGO measure(s):

One (1) at four (4) feet in length, and four (4) feet in width for a total of sixteen (16) square feet.

The location of said privilege shall be as shown on prints kept on file with the Department of Business Affairs and Consumer Protection and the Office of the City Clerk.

Said privilege shall be constructed in accordance with plans and specifications approved by the Department of Transportation (Office of Underground Coordination) and Department of Water Management.

This grant of privilege in the public way shall be subject to the provisions of Section 10-28-015 and all other required provisions of the Municipal Code of Chicago.

The grantee shall pay to the City of Chicago as compensation for the privilege #1120336 herein granted the sum of four hundred (\$400.00) per annum in advance.

A 25% penalty will be added for payments received after due date.

The permit holder agrees to hold the City of Chicago harmless for any damage, relocation or replacement costs associated with damage, relocation or removal of private property caused by the City performing work in the public way.

Authority herein given and granted for a period of five (5) years from and after 10/06/2015.

Alderman



Brian Hopkins 2nd Ward

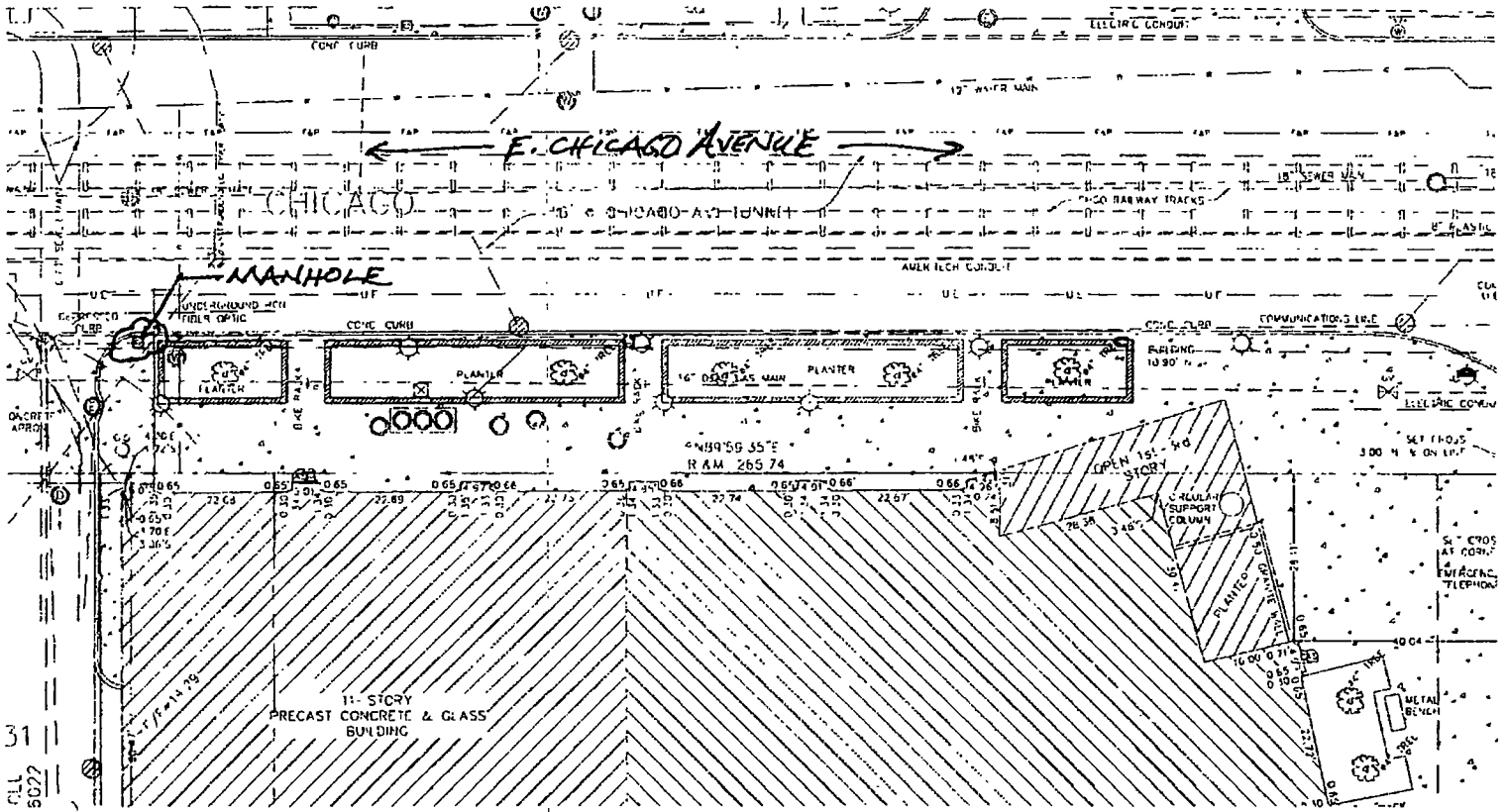

31
ALL
5077

PARTIAL SITE PLAN
MANHOLE, E. CHICAGO AVE
69273-3 PNL 1094080



10/21/2015

Alderman **Brian Hopkins**
Ward # **02**
City of Chicago
City Hall, Room **200**
121 North LaSalle Street
Chicago, Illinois 60602

Re: An ordinance to use and maintain a portion of the public right-of-way for **one (1) manhole(s)** for **NORTHWESTERN MEMORIAL HOSPITAL**, adjacent to the premises known as **245 E. Chicago Ave.**.

Dear Alderman **Brian Hopkins**:

The applicant referenced above has requested the use of the public right-of-way for a **manhole(s)**. An ordinance has been prepared by the Department of Business Affairs and Consumer Protection – Small Business Center - Public Way Use Unit for presentation to the City Council. Because this request was made for properties located in your ward, as approved by you as per the attached, I respectfully request that you introduce the attached ordinance at the next City Council meeting.

If you have any questions regarding this ordinance, please contact Anthony Bertuca at (312) 744-5506.

Department of Business Affairs and Consumer Protection



City of Chicago



O2015-7726

Office of the City Clerk

Document Tracking Sheet

Meeting Date:	10/21/2015
Sponsor(s):	Dowell (3)
Type:	Ordinance
Title:	Grant(s) of privilege in public way for Norfolk Southern Railway Co.
Committee(s) Assignment:	Committee on Transportation and Public Way

ORDINANCE

Norfolk Southern Railway Company

Acct. No. 25288 - 4

Permit No. 1120068

Be It Ordained by the City Council of the City of Chicago:

SECTION 1. Permission and authority are hereby given and granted to Norfolk Southern Railway Company, upon the terms and subject to the conditions of this ordinance to construct, install, maintain and use one (1) Vault(s) under the public right-of-way adjacent to its premises known as 482 W. 51st St..

Said Vault(s) at W. 51st Street measure(s):

One (1) at twelve point six seven (12.67) feet in length, and five point one seven (5.17) feet in width for a total of sixty-five point five (65.5) square feet.

The location of said privilege shall be as shown on prints kept on file with the Department of Business Affairs and Consumer Protection and the Office of the City Clerk.

Said privilege shall be constructed in accordance with plans and specifications approved by the Department of Transportation (Office of Underground Coordination).

This grant of privilege in the public way shall be subject to the provisions of Section 10-28-015 and all other required provisions of the Municipal Code of Chicago.

The grantee shall pay to the City of Chicago as compensation for the privilege #1120068 herein granted the sum of four hundred (\$400.00) per annum in advance.

A 25% penalty will be added for payments received after due date.

The permit holder agrees to hold the City of Chicago harmless for any damage, relocation or replacement costs associated with damage, relocation or removal of private property caused by the City performing work in the public way.

Authority herein given and granted for a period of five (5) years from and after Date of Passage.

Alderman

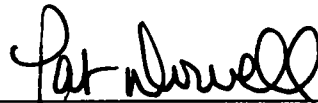

Pat Dowell 3rd Ward

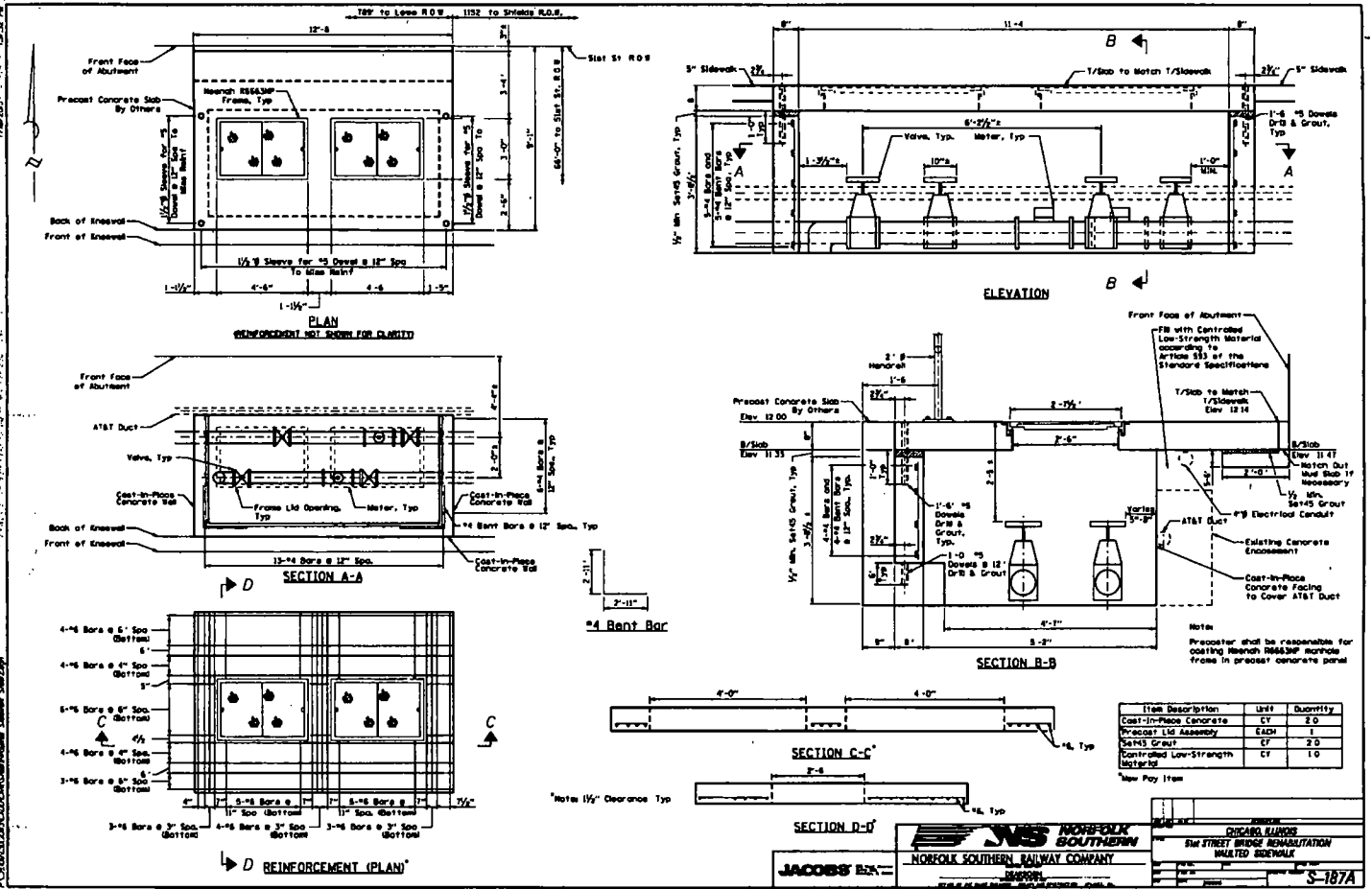

JACOBS ENGINEERS AND ARCHITECTS

NORFOLK SOUTHERN

NORFOLK SOUTHERN RAILWAY COMPANY

CHICAGO, ILLINOIS

5th STREET BRIDGE REMEDIATION

WALKED SIDEWALK

DATE: 10/11/11

PROJECT NO: 11-187A



10/21/2015

Alderman Pat Dowell
Ward # 03
City of Chicago
City Hall, Room 200
121 North LaSalle Street
Chicago, Illinois 60602

Re: An ordinance to use and maintain a portion of the public right-of-way for **one (1) vault(s)** for **Norfolk Southern Railway Company**, adjacent to the premises known as **482 W. 51st St.**

Dear Alderman Pat Dowell:

The applicant referenced above has requested the use of the public right-of-way for a **vault(s)**. An ordinance has been prepared by the Department of Business Affairs and Consumer Protection – Small Business Center - Public Way Use Unit for presentation to the City Council. Because this request was made for properties located in your ward, as approved by you as per the attached, I respectfully request that you introduce the attached ordinance at the next City Council meeting.

If you have any questions regarding this ordinance, please contact Anthony Bertuca at (312) 744-5506.

Department of Business Affairs and Consumer Protection



City of Chicago



O2015-7730

Office of the City Clerk

Document Tracking Sheet

Meeting Date:	10/21/2015
Sponsor(s):	Burns (4)
Type:	Ordinance
Title:	Grant(s) of privilege in public way for Ancona School
Committee(s) Assignment:	Committee on Transportation and Public Way

ORDINANCE
ANCONA SCHOOL
Acct. No. 401094 - 1
Permit No. 1120152

Be It Ordained by the City Council of the City of Chicago:

SECTION 1. Permission and authority are hereby given and granted to ANCONA SCHOOL, upon the terms and subject to the conditions of this ordinance to construct, install, maintain and use Sleeve for a Sprinkler System under the public right-of-way adjacent to its premises known as 4770 S. Dorchester Ave..

Said Sleeve for Sprinkler System at Public Alley measure(s):

One (1) at fifteen (15) feet in length, and point six seven (.67) feet in width for a total of ten point zero five (10.05) square feet. Said sleeve for irrigation system shall be approximately eighteen (18) inches below grade level.

The location of said privilege shall be as shown on prints kept on file with the Department of Business Affairs and Consumer Protection and the Office of the City Clerk.

Said privilege shall be constructed in accordance with plans and specifications approved by the Department of Transportation (Office of Underground Coordination) and Department of Water Management.

This grant of privilege in the public way shall be subject to the provisions of Section 10-28-015 and all other required provisions of the Municipal Code of Chicago.

The grantee shall pay to the City of Chicago as compensation for the privilege #1120152 herein granted the sum of four hundred (\$400.00) per annum in advance.

A 25% penalty will be added for payments received after due date.

The permit holder agrees to hold the City of Chicago harmless for any damage, relocation or replacement costs associated with damage, relocation or removal of private property caused by the City performing work in the public way.

Authority herein given and granted for a period of five (5) years from and after Date of Passage.

Alderman



William D. Burns 4th Ward

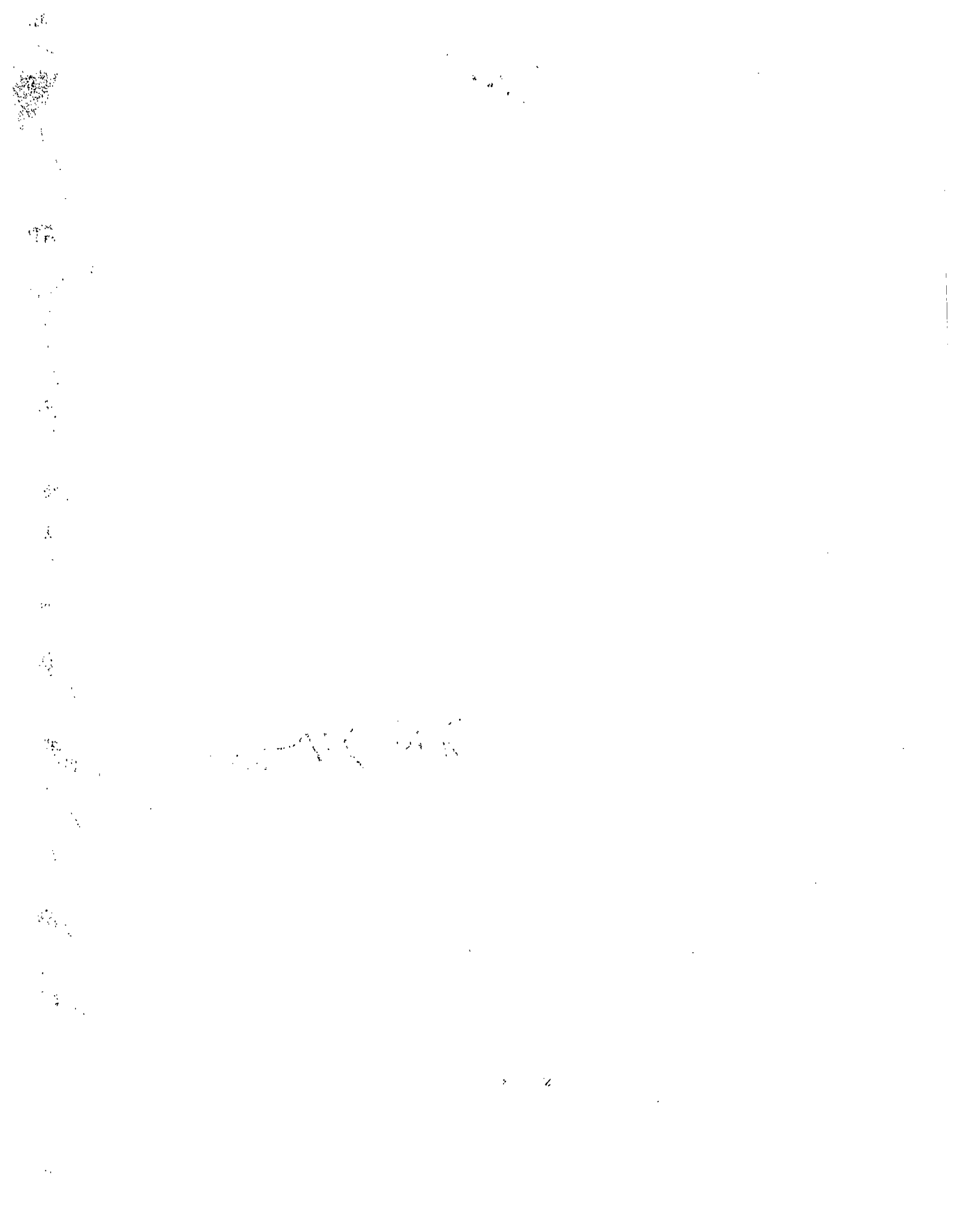

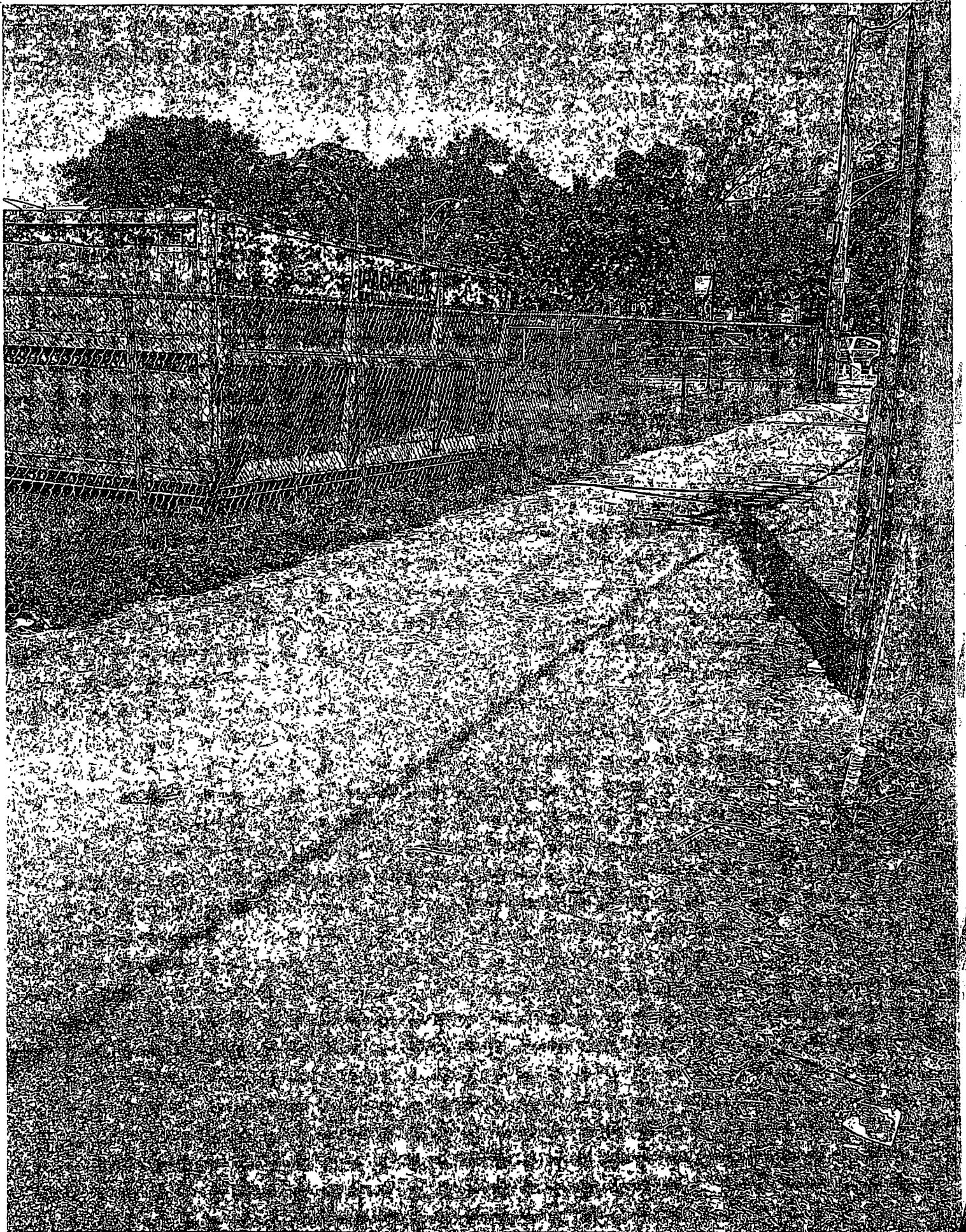



10/21/2015

Alderman **William D. Burns**
Ward # 04
City of Chicago
City Hall, Room 305
121 North LaSalle Street
Chicago, Illinois 60602

Re: An ordinance to use and maintain a portion of the public right-of-way for **one (1) sprinkler system(s)** for **ANCONA SCHOOL**, adjacent to the premises known as **4770 S. Dorchester Ave.**

Dear Alderman **William D. Burns**:

The applicant referenced above has requested the use of the public right-of-way for a **sprinkler system(s)**. An ordinance has been prepared by the Department of Business Affairs and Consumer Protection – Small Business Center - Public Way Use Unit for presentation to the City Council. Because this request was made for properties located in your ward, as approved by you as per the attached, I respectfully request that you introduce the attached ordinance at the next City Council meeting.

If you have any questions regarding this ordinance, please contact Anthony Bertuca at (312) 744-5506.

Department of Business Affairs and Consumer Protection



City of Chicago



O2015-7731

Office of the City Clerk Document Tracking Sheet

Meeting Date:	10/21/2015
Sponsor(s):	Burns (4)
Type:	Ordinance
Title:	Grant(s) of privilege in public way for Subway
Committee(s) Assignment:	Committee on Transportation and Public Way

ORDINANCE
SUBWAY
Acct. No. 393933 - 1
Permit No. 1115432

Be It Ordained by the City Council of the City of Chicago:

SECTION 1. Permission and authority are hereby given and granted to SUBWAY, upon the terms and subject to the conditions of this ordinance to maintain and use one (1) sign(s) projecting over the public right-of-way attached to its premises known as 749 E. 47th St..

Said sign structure(s) measures as follows; along Cottage Grove:

One (1) at thirteen point five (13.5) feet in length, two point five (2.5) feet in height and thirteen (13) feet above grade level.

The location of said privilege shall be as shown on prints kept on file with the Department of Business Affairs and Consumer Protection and the Office of the City Clerk.

Said privilege shall be constructed in accordance with plans and specifications approved by the Department of Transportation (Division of Project Development) and Zoning Department - Signs.

This grant of privilege in the public way shall be subject to the provisions of Section 10-28-015 and all other required provisions of the Municipal Code of Chicago.

The grantee shall pay to the City of Chicago as compensation for the privilege #1115432 herein granted the sum of three hundred (\$300.00) per annum in advance.

A 25% penalty will be added for payments received after due date.

The permit holder agrees to hold the City of Chicago harmless for any damage, relocation or replacement costs associated with damage, relocation or removal of private property caused by the City performing work in the public way.

Authority herein given and granted for a period of five (5) years from and after Date of Passage.

Alderman



William D. Burns 4th Ward

11

11/11/11

Internally Illuminated Raceway Mounted Channel Letters

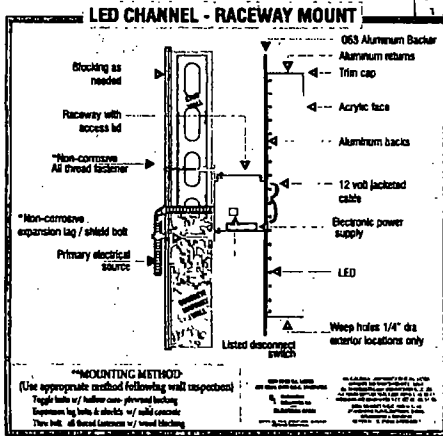
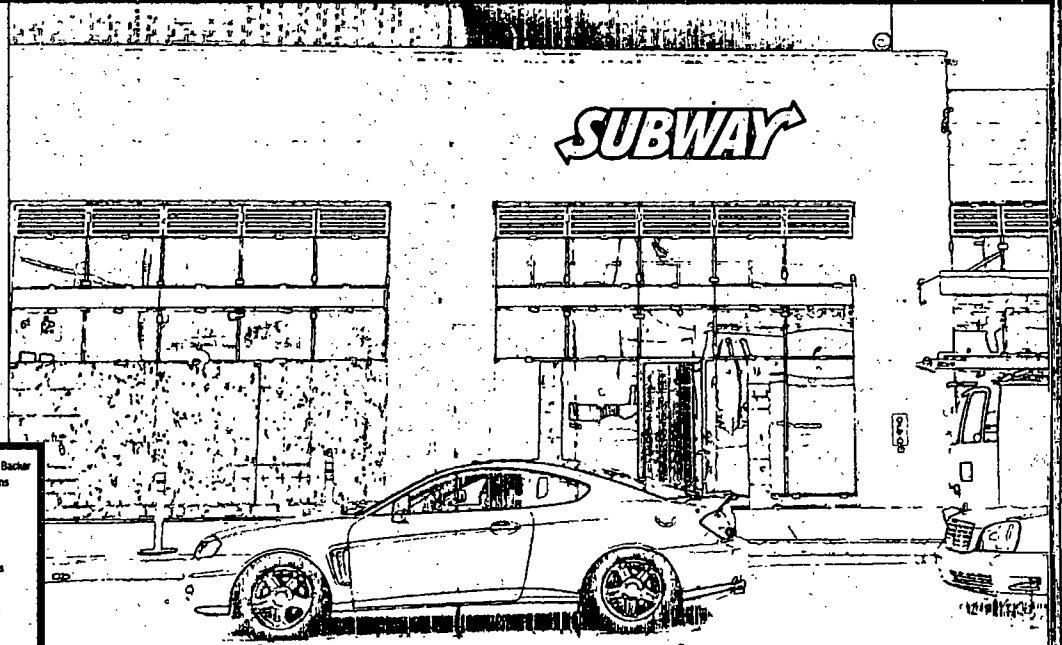

13' 6"



30"

STRICTLY NEON, INC.
 4608 W. 137TH ST.
 CRESTWOOD, IL 60445
 (708)597-1616
 (708)597-8638 FAX

LOCATION
 749 E. 47TH
 CHICAGO, IL

CLIENT
 SUBWAY

INDIVIDUALLY INTERNALLY ILLUMINATED CHANNEL LETTERS

- RACEWAY MOUNTED
- FACES 3/16" 7328 WHITE AND 2485 YELLOW
- RETURNS 5" DEEP, BLACK
- TRIM CAP 1" BLACK
- G.E. GELCO CORE WHITE LEDS
- LOW VOLTAGE POWER SUPPLIES



10/21/2015

Alderman William D. Burns
Ward # 04
City of Chicago
City Hall, Room 305
121 North LaSalle Street
Chicago, Illinois 60602

Re: An ordinance to use and maintain a portion of the public right-of-way for **one (1) sign(s)** for **SUBWAY**, adjacent to the premises known as **749 E. 47th St.**

Dear Alderman **William D. Burns**:

The applicant referenced above has requested the use of the public right-of-way for a **sign(s)**. An ordinance has been prepared by the Department of Business Affairs and Consumer Protection – Small Business Center - Public Way Use Unit for presentation to the City Council. Because this request was made for properties located in your ward, as approved by you as per the attached, I respectfully request that you introduce the attached ordinance at the next City Council meeting.

If you have any questions regarding this ordinance, please contact Anthony Bertuca at (312) 744-5506.

Department of Business Affairs and Consumer Protection



City of Chicago



O2015-7736

Office of the City Clerk

Document Tracking Sheet

Meeting Date:	10/21/2015
Sponsor(s):	Hairston (5)
Type:	Ordinance
Title:	Grant(s) of privilege in public way for Chicago Park District- Office of Comptroller
Committee(s) Assignment:	Committee on Transportation and Public Way

ORDINANCE
CHICAGO PARK DISTRICT- Office of Comptroller
Acct. No. 17339 - 1
Permit No. 1120389

Be It Ordained by the City Council of the City of Chicago:

SECTION 1. Permission and authority are hereby given and granted to CHICAGO PARK DISTRICT- Office of Comptroller, upon the terms and subject to the conditions of this ordinance to maintain and use, as now constructed, Chilled Water Pipe(s) under the public right-of-way adjacent to its premises known as 860 E. 59th St..

Said Chilled Water Pipe(s) at MIDWAY PLAISANCE measure(s):

One (1) at sixty-eight (68) feet in length, and five (5) feet in width for a total of three hundred forty (340) square feet. Existing chilled water pipes under and across the public way to service Midway skating rink.

The location of said privilege shall be as shown on prints kept on file with the Department of Business Affairs and Consumer Protection and the Office of the City Clerk.

Said privilege shall be constructed in accordance with plans and specifications approved by the Department of Transportation (Office of Underground Coordination) and Department of Water Management.

This grant of privilege in the public way shall be subject to the provisions of Section 10-28-015 and all other required provisions of the Municipal Code of Chicago.

The grantee shall pay to the City of Chicago as compensation for the privilege #1120389 herein granted the sum of zero (\$.00) per annum in advance.

A 25% penalty will be added for payments received after due date.

The permit holder agrees to hold the City of Chicago harmless for any damage, relocation or replacement costs associated with damage, relocation or removal of private property caused by the City performing work in the public way.

Authority herein given and granted for a period of five (5) years from and after 09/27/2015.

Alderman

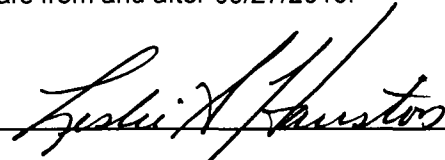

Leslie Hairston 5th Ward

1244.97'

USE

BURY MIN. 5' BELOW GRADE

8" CHWR

8" CHWS

NOTE:
SEE DWG. MP-4 FOR
EQPT. SCHEDULE

8" CHWR

8" CHWS

4'-0" WIDE HEADER TRENCH

208'

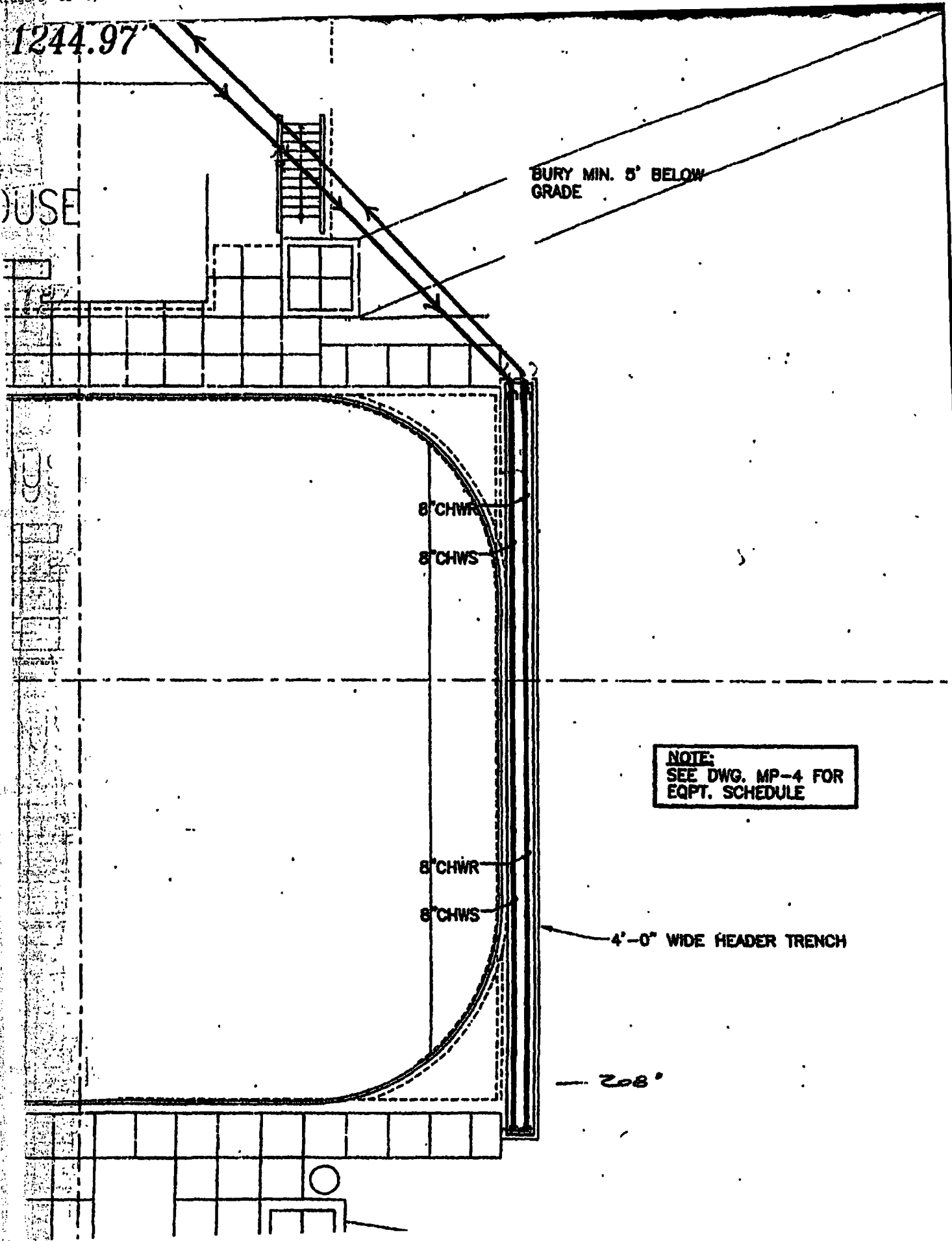



10/21/2015

Alderman Leslie Hairston
Ward # 05
City of Chicago
City Hall, Room 300
121 North LaSalle Street
Chicago, Illinois 60602

Re: An ordinance to use and maintain a portion of the public right-of-way for **one (1) pipe(s)** for
CHICAGO PARK DISTRICT- Office of Comptroller, adjacent to the premises known as **860 E.
59th St.**.

Dear Alderman **Leslie Hairston**:

The applicant referenced above has requested the use of the public right-of-way for **pipe(s)**. An ordinance has been prepared by the Department of Business Affairs and Consumer Protection – Small Business Center - Public Way Use Unit for presentation to the City Council. Because this request was made for properties located in your ward, as approved by you as per the attached, I respectfully request that you introduce the attached ordinance at the next City Council meeting.

If you have any questions regarding this ordinance, please contact Anthony Bertuca at (312) 744-5506.

Department of Business Affairs and Consumer Protection



City of Chicago



O2015-7743

Office of the City Clerk

Document Tracking Sheet

Meeting Date:	10/21/2015
Sponsor(s):	Lopez (15)
Type:	Ordinance
Title:	Grant(s) of privilege in public way for Walgreens No. 05356 - light fixtures
Committee(s) Assignment:	Committee on Transportation and Public Way

ORDINANCE
Walgreens # 05356
Acct. No. 7551 - 73
Permit No. 1119466

Be It Ordained by the City Council of the City of Chicago:

SECTION 1. Permission and authority are hereby given and granted to Walgreens # 05356, upon the terms and subject to the conditions of this ordinance to maintain and use, as now constructed, four (4) Light Fixture(s) projecting over the public right-of-way adjacent to its premises known as 4710 S. Western Ave..

Said Light Fixture(s) at S. Western Avenue measure(s):

Four (4) at point five eight (.58) feet in length, two (2) feet in width and five point four one (5.41) feet above grade level.

The location of said privilege shall be as shown on prints kept on file with the Department of Business Affairs and Consumer Protection and the Office of the City Clerk.

Said privilege shall be constructed in accordance with plans and specifications approved by the Department of Transportation (Division of Project Development).

This grant of privilege in the public way shall be subject to the provisions of Section 10-28-015 and all other required provisions of the Municipal Code of Chicago.

The grantee shall pay to the City of Chicago as compensation for the privilege #1119466 herein granted the sum of ninety (\$90.00) per annum in advance.

A 25% penalty will be added for payments received after due date.

The permit holder agrees to hold the City of Chicago harmless for any damage, relocation or replacement costs associated with damage, relocation or removal of private property caused by the City performing work in the public way.

Authority herein given and granted for a period of five (5) years from and after 01/13/2014.

Alderman

Raymond A. Lopez 15th Ward

SECTION ELEVATION AND SECTION NOTES

1. SECTION ELEVATION AND SECTION NOTES

2. SECTION ELEVATION AND SECTION NOTES

3. SECTION ELEVATION AND SECTION NOTES

4. SECTION ELEVATION AND SECTION NOTES

5. SECTION ELEVATION AND SECTION NOTES

PROJECT TYPE

ARCHITECTURE

RESIDENTIAL

COMMERCIAL

INDUSTRIAL

AGRICULTURAL

OTHER

PROJECT NAME

1234567890

CLIENT

ABC COMPANY

DATE

12/31/2023

SCALE

1/4" = 1'-0"

PROJECT NO.

A2 01

DATE

12/31/2023

BY

ABC COMPANY

CHECKED BY

DEF COMPANY

APPROVED BY

GHI COMPANY

1 NORTH ELEVATION

2 EAST ELEVATION

3 WEST ELEVATION

4 SOUTH ELEVATION

5 WALL ELEVATION



2nd ATTEMPT AT INTRODUCTION

10/21/2015

Alderman **Raymond A. Lopez**
Ward # 15
City of Chicago
City Hall, Room 300
121 North LaSalle Street
Chicago, Illinois 60602

Re: An ordinance to use and maintain a portion of the public right-of-way for **four (4) light fixture(s)** for **Walgreens # 05356**, adjacent to the premises known as **4710 S. Western Ave.**.

Dear Alderman **Raymond A. Lopez**:

The applicant referenced above has requested the use of the public right-of-way for a **light fixture(s)**. An ordinance has been prepared by the Department of Business Affairs and Consumer Protection – Small Business Center - Public Way Use Unit for presentation to the City Council. Because this request was made for properties located in your ward, as approved by you as per the attached, I respectfully request that you introduce the attached ordinance at the next City Council meeting.

If you have any questions regarding this ordinance, please contact Anthony Bertuca at (312) 744-5506.

Department of Business Affairs and Consumer Protection



City of Chicago



O2015-7746

Office of the City Clerk

Document Tracking Sheet

Meeting Date:	10/21/2015
Sponsor(s):	Lopez (15)
Type:	Ordinance
Title:	Grant(s) of privilege in public way for Walgreens No. 05356 - sign
Committee(s) Assignment:	Committee on Transportation and Public Way

ORDINANCE
Walgreens # 05356
Acct. No. 7551 - 73
Permit No. 1119465

Be It Ordained by the City Council of the City of Chicago:

SECTION 1. Permission and authority are hereby given and granted to Walgreens # 05356, upon the terms and subject to the conditions of this ordinance to maintain and use one (1) sign(s) projecting over the public right-of-way attached to its premises known as 4710 S. Western Ave..

Said sign structure(s) measures as follows; along S. Western:
One (1) at five (5) feet in length, fourteen (14) feet in height and ten point seven five (10.75) feet above grade level.

The location of said privilege shall be as shown on prints kept on file with the Department of Business Affairs and Consumer Protection and the Office of the City Clerk.

Said privilege shall be constructed in accordance with plans and specifications approved by the Department of Transportation (Division of Project Development) and Zoning Department - Signs.

This grant of privilege in the public way shall be subject to the provisions of Section 10-28-015 and all other required provisions of the Municipal Code of Chicago.

The grantee shall pay to the City of Chicago as compensation for the privilege #1119465 herein granted the sum of three hundred (\$300.00) per annum in advance.

A 25% penalty will be added for payments received after due date.

The permit holder agrees to hold the City of Chicago harmless for any damage, relocation or replacement costs associated with damage, relocation or removal of private property caused by the City performing work in the public way.

Authority herein given and granted for a period of five (5) years from and after 11/19/2013.

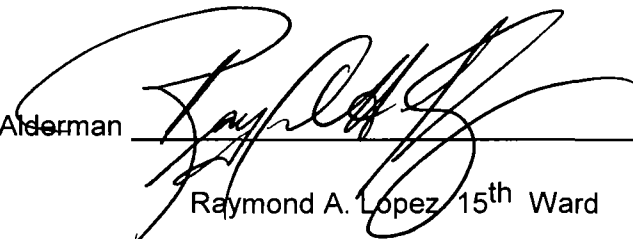
Alderman 
Raymond A. Lopez 15th Ward

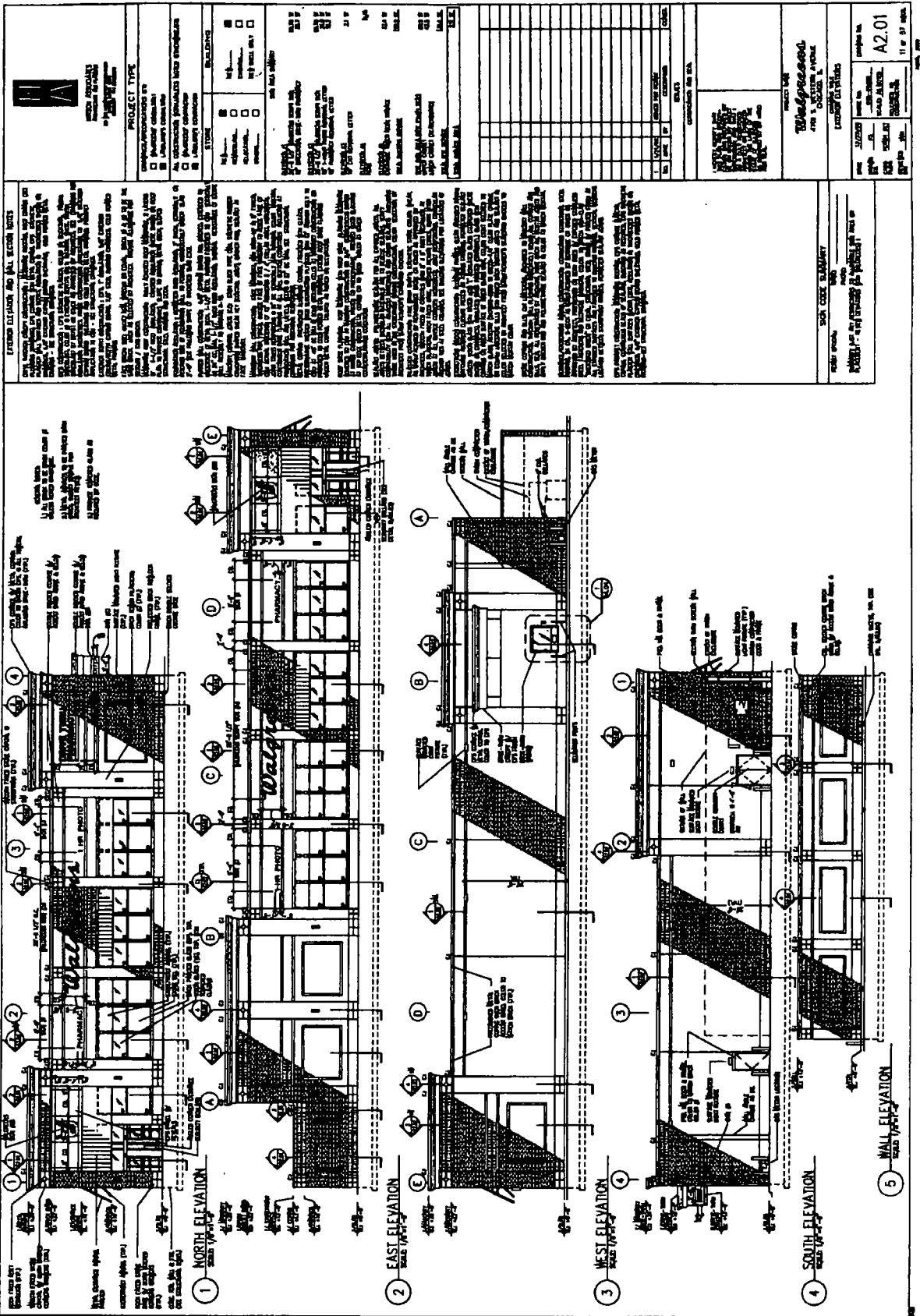



2nd ATTEMPT AT INTRODUCTION

10/21/2015

Alderman **Raymond A. Lopez**
Ward # 15
City of Chicago
City Hall, Room 300
121 North LaSalle Street
Chicago, Illinois 60602

Re: An ordinance to use and maintain a portion of the public right-of-way for **one (1) sign(s)** for **Walgreens # 05356**, adjacent to the premises known as **4710 S. Western Ave.**.

Dear Alderman **Raymond A. Lopez**:

The applicant referenced above has requested the use of the public right-of-way for a **sign(s)**. An ordinance has been prepared by the Department of Business Affairs and Consumer Protection – Small Business Center - Public Way Use Unit for presentation to the City Council. Because this request was made for properties located in your ward, as approved by you as per the attached, I respectfully request that you introduce the attached ordinance at the next City Council meeting.

If you have any questions regarding this ordinance, please contact Anthony Bertuca at (312) 744-5506.

Department of Business Affairs and Consumer Protection



City of Chicago



O2015-7750

Office of the City Clerk

Document Tracking Sheet

Meeting Date:	10/21/2015
Sponsor(s):	Lopez (15)
Type:	Ordinance
Title:	Grant(s) of privilege in public way for Walgreens No. 06641 - light fixtures
Committee(s) Assignment:	Committee on Transportation and Public Way

ORDINANCE
WALGREENS # 06641
Acct. No. 147 - 75
Permit No. 1119538

Be It Ordained by the City Council of the City of Chicago:

SECTION 1. Permission and authority are hereby given and granted to WALGREENS # 06641, upon the terms and subject to the conditions of this ordinance to maintain and use, as now constructed, five (5) Light Fixture(s) projecting over the public right-of-way adjacent to its premises known as 1614 W. 47th St..

Said Light Fixture(s) at W.47th measure(s):

Five (5) at eighty (80) feet in length, point six (.6) feet in width and twelve (12) feet above grade level.

The location of said privilege shall be as shown on prints kept on file with the Department of Business Affairs and Consumer Protection and the Office of the City Clerk.

Said privilege shall be constructed in accordance with plans and specifications approved by the Department of Transportation (Division of Project Development).

This grant of privilege in the public way shall be subject to the provisions of Section 10-28-015 and all other required provisions of the Municipal Code of Chicago.

The grantee shall pay to the City of Chicago as compensation for the privilege #1119538 herein granted the sum of ninety-five (\$95.00) per annum in advance.

A 25% penalty will be added for payments received after due date.

The permit holder agrees to hold the City of Chicago harmless for any damage, relocation or replacement costs associated with damage, relocation or removal of private property caused by the City performing work in the public way.

Authority herein given and granted for a period of five (5) years from and after 12/17/2013.

Alderman

Raymond A. Lopez 15th Ward

1 ELEVATION
1/4" = 1'-0"

2 ELEVATION
1/4" = 1'-0"

3 SECTION
1/4" = 1'-0"

4 ELEVATION SIGN LIGHTING
1/4" = 1'-0"

5 PLAN SECTION
1/4" = 1'-0"

6 TOP VIEW SIGN
1/4" = 1'-0"

7 SECTION DETAIL
1/4" = 1'-0"

8 ANCHOR BOLT DETAIL
1/4" = 1'-0"

9 PIER FOR SIGN DETAIL
1/4" = 1'-0"

10 GROUNDING DETAIL
1/4" = 1'-0"

KEYED NOTES

<p>1. 2" x 2" x 1/4" ANCHOR BOLT</p> <p>2. 1/2" ANCHOR BOLT</p> <p>3. 1/2" ANCHOR BOLT</p> <p>4. 1/2" ANCHOR BOLT</p> <p>5. 1/2" ANCHOR BOLT</p> <p>6. 1/2" ANCHOR BOLT</p> <p>7. 1/2" ANCHOR BOLT</p> <p>8. 1/2" ANCHOR BOLT</p> <p>9. 1/2" ANCHOR BOLT</p> <p>10. 1/2" ANCHOR BOLT</p>	<p>11. 1/2" ANCHOR BOLT</p> <p>12. 1/2" ANCHOR BOLT</p> <p>13. 1/2" ANCHOR BOLT</p> <p>14. 1/2" ANCHOR BOLT</p> <p>15. 1/2" ANCHOR BOLT</p> <p>16. 1/2" ANCHOR BOLT</p> <p>17. 1/2" ANCHOR BOLT</p> <p>18. 1/2" ANCHOR BOLT</p> <p>19. 1/2" ANCHOR BOLT</p> <p>20. 1/2" ANCHOR BOLT</p>
--	---

STRUCTURAL GENERAL NOTES

- ALL MATERIALS SHOWN IN QUANTITY ARE TO BE USED UNLESS OTHERWISE NOTED.
- ALL MATERIALS SHALL BE OF THE QUALITY AND GRADE SPECIFIED.
- ALL MATERIALS SHALL BE OF THE QUALITY AND GRADE SPECIFIED.
- ALL MATERIALS SHALL BE OF THE QUALITY AND GRADE SPECIFIED.
- ALL MATERIALS SHALL BE OF THE QUALITY AND GRADE SPECIFIED.
- ALL MATERIALS SHALL BE OF THE QUALITY AND GRADE SPECIFIED.
- ALL MATERIALS SHALL BE OF THE QUALITY AND GRADE SPECIFIED.
- ALL MATERIALS SHALL BE OF THE QUALITY AND GRADE SPECIFIED.
- ALL MATERIALS SHALL BE OF THE QUALITY AND GRADE SPECIFIED.
- ALL MATERIALS SHALL BE OF THE QUALITY AND GRADE SPECIFIED.
- ALL MATERIALS SHALL BE OF THE QUALITY AND GRADE SPECIFIED.
- ALL MATERIALS SHALL BE OF THE QUALITY AND GRADE SPECIFIED.
- ALL MATERIALS SHALL BE OF THE QUALITY AND GRADE SPECIFIED.
- ALL MATERIALS SHALL BE OF THE QUALITY AND GRADE SPECIFIED.
- ALL MATERIALS SHALL BE OF THE QUALITY AND GRADE SPECIFIED.
- ALL MATERIALS SHALL BE OF THE QUALITY AND GRADE SPECIFIED.

COLORS

DESCRIPTION	COLOR
STRUCTURAL STEEL	BLACK
CONCRETE	GRAY
PAINT	WHITE

NOTES

THIS DRAWING IS ONLY SHOWN FOR REFERENCE. FINAL DESIGN OF SIGNAGE AND STRUCTURE IS BY THE SIGN CONTRACTOR.

BIG AREA SUMMARY

Project Name	1715 17
Project No.	1715 17
Date	11.16.17

GENERAL NOTES

THE ABOVE DRAWING SHALL BE USED AS A GUIDE ONLY. THE CONTRACTOR SHALL BE RESPONSIBLE FOR THE FINAL DESIGN AND CONSTRUCTION OF THE SIGNAGE AND STRUCTURE. THE CONTRACTOR SHALL BE RESPONSIBLE FOR OBTAINING ALL NECESSARY PERMITS AND APPROVALS FROM THE LOCAL AUTHORITIES.

NOTES

THIS DRAWING IS ONLY SHOWN FOR REFERENCE. FINAL DESIGN OF SIGNAGE AND STRUCTURE IS BY THE SIGN CONTRACTOR.



UNITED INSULATED STRUCTURES CORP.

1715 17

11.16.17

A5.1



2nd ATTEMPT AT INTRODUCTION

10/21/2015

Alderman **Raymond A. Lopez**
Ward # 15
City of Chicago
City Hall, Room 300
121 North LaSalle Street
Chicago, Illinois 60602

Re: An ordinance to use and maintain a portion of the public right-of-way for **five (5) light fixture(s)** for **WALGREENS # 06641**, adjacent to the premises known as **1614 W. 47th St.**.

Dear Alderman **Raymond A. Lopez**:

The applicant referenced above has requested the use of the public right-of-way for a **light fixture(s)**. An ordinance has been prepared by the Department of Business Affairs and Consumer Protection – Small Business Center - Public Way Use Unit for presentation to the City Council. Because this request was made for properties located in your ward, as approved by you as per the attached, I respectfully request that you introduce the attached ordinance at the next City Council meeting.

If you have any questions regarding this ordinance, please contact Anthony Bertuca at (312) 744-5506.

Department of Business Affairs and Consumer Protection



City of Chicago



O2015-7751

Office of the City Clerk

Document Tracking Sheet

Meeting Date:	10/21/2015
Sponsor(s):	Lopez (15)
Type:	Ordinance
Title:	Grant(s) of privilege in public way for Walgreens No. 06641 - occupation of space
Committee(s) Assignment:	Committee on Transportation and Public Way

ORDINANCE
WALGREENS # 06641
Acct. No. 147 - 75
Permit No. 1119539

Be It Ordained by the City Council of the City of Chicago:

SECTION 1. Permission and authority are hereby given and granted to WALGREENS # 06641, upon the terms and subject to the conditions of this ordinance to maintain and use, as now constructed, Occupation of Space on the public right-of-way adjacent to its premises known as 1614 W. 47th St.. A portion of an existing sixteen (16) foot wide public alley for purposes of vehicular ingress and egress between parking area of the store. Existing area of the alley being used is two hundred seven (207) feet in length and sixteen (16) feet in width for a total of three thousand three hundred twelve (3,312) square feet. Existing alley connects West 47th street to West 46th Street, between South Ashland Avenue and South Marshfield Avenue.

The location of said privilege shall be as shown on prints kept on file with the Department of Business Affairs and Consumer Protection and the Office of the City Clerk.

Said privilege shall be constructed in accordance with plans and specifications approved by the Department of Planning and Development, Department of Transportation (Division of Project Development), and Department of Transportation (Office of Underground Coordination).

This grant of privilege in the public way shall be subject to the provisions of Section 10-28-015 and all other required provisions of the Municipal Code of Chicago.

The grantee shall pay to the City of Chicago as compensation for the privilege #1119539 herein granted the sum of four thousand sixty-three (\$4,063.00) per annum in advance.

A 25% penalty will be added for payments received after due date.

The permit holder agrees to hold the City of Chicago harmless for any damage, relocation or replacement costs associated with damage, relocation or removal of private property caused by the City performing work in the public way

Authority herein given and granted for a period of five (5) years from and after 02/11/2014.

Alderman

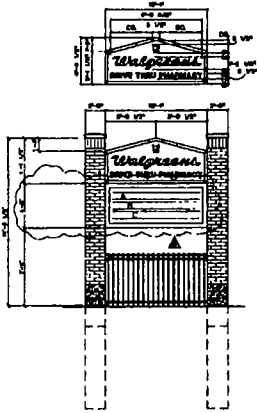

Raymond A. Lopez 15th Ward

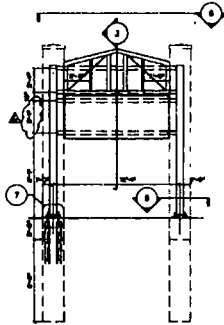

1 ELEVATION
10'-0" x 10'-0"

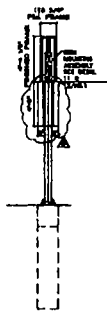

2 ELEVATION
10'-0" x 10'-0"



3 SECTION
10'-0" x 10'-0"

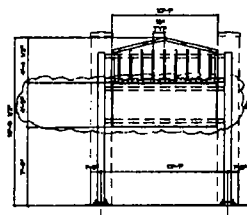

4 ELEVATION SIGN LIGHTING
10'-0" x 10'-0"

NOTE
THIS DRAWING IS ONLY
SHOWN FOR REFERENCE
FINAL DESIGN OF SIGNAGE
AND STRUCTURE IS BY THE
SIGN CONTRACTOR

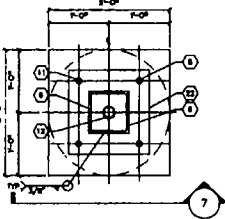

5 PLAN SECTION
10'-0" x 10'-0"

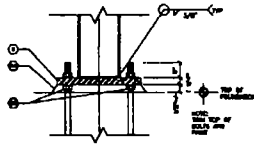

7 SECTION DETAIL
10'-0" x 10'-0"

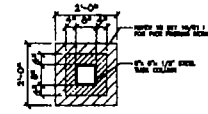

9 PIER FOR SIGN DETAIL
10'-0" x 10'-0"



6 TOP VIEW SIGN
10'-0" x 10'-0"

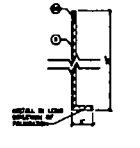

8 ANCHOR BOLT DETAIL
10'-0" x 10'-0"

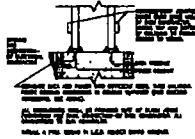

10 GROUNDING DETAIL
10'-0" x 10'-0"

KEYED NOTES	
1. 2" x 2" x 1/4" ANCHOR BOLT	11. 1/2" x 1/4" ANCHOR BOLT WITH 1/2" DIA. WELD
2. 1/2" x 1/4" ANCHOR BOLT WITH 1/2" DIA. WELD	12. 1/2" x 1/4" ANCHOR BOLT WITH 1/2" DIA. WELD
3. 1/2" x 1/4" ANCHOR BOLT WITH 1/2" DIA. WELD	13. 1/2" x 1/4" ANCHOR BOLT WITH 1/2" DIA. WELD
4. 1/2" x 1/4" ANCHOR BOLT WITH 1/2" DIA. WELD	14. 1/2" x 1/4" ANCHOR BOLT WITH 1/2" DIA. WELD
5. 1/2" x 1/4" ANCHOR BOLT WITH 1/2" DIA. WELD	15. 1/2" x 1/4" ANCHOR BOLT WITH 1/2" DIA. WELD
6. 1/2" x 1/4" ANCHOR BOLT WITH 1/2" DIA. WELD	16. 1/2" x 1/4" ANCHOR BOLT WITH 1/2" DIA. WELD
7. 1/2" x 1/4" ANCHOR BOLT WITH 1/2" DIA. WELD	17. 1/2" x 1/4" ANCHOR BOLT WITH 1/2" DIA. WELD
8. 1/2" x 1/4" ANCHOR BOLT WITH 1/2" DIA. WELD	18. 1/2" x 1/4" ANCHOR BOLT WITH 1/2" DIA. WELD
9. 1/2" x 1/4" ANCHOR BOLT WITH 1/2" DIA. WELD	19. 1/2" x 1/4" ANCHOR BOLT WITH 1/2" DIA. WELD
10. 1/2" x 1/4" ANCHOR BOLT WITH 1/2" DIA. WELD	20. 1/2" x 1/4" ANCHOR BOLT WITH 1/2" DIA. WELD

COLORS	STRUCTURAL GENERAL NOTES
<p>CONCRETE: PORTLAND CEMENT, TYPE I, 3000 PSI MIN. COMPRESSIVE STRENGTH.</p> <p>STEEL: A36, 50KSI YIELD STRENGTH.</p> <p>WALGREENS SIGN: 1/2" x 1/4" ANCHOR BOLT WITH 1/2" DIA. WELD.</p> <p>ANCHOR BOLT: 1/2" x 1/4" ANCHOR BOLT WITH 1/2" DIA. WELD.</p> <p>GROUNDING: 1/2" x 1/4" ANCHOR BOLT WITH 1/2" DIA. WELD.</p>	<p>1. ALL ALUMINUM SURFACES TO BE ANODIZED.</p> <p>2. ALL STRUCTURAL STEEL SHALL BE GALV. GALV.</p> <p>3. ALL STRUCTURAL STEEL SHALL BE GALV. GALV.</p> <p>4. ALL STEEL SHALL BE GALV. GALV.</p> <p>5. ALL STEEL SHALL BE GALV. GALV.</p> <p>6. ALL STEEL SHALL BE GALV. GALV.</p> <p>7. ALL STEEL SHALL BE GALV. GALV.</p> <p>8. ALL STEEL SHALL BE GALV. GALV.</p> <p>9. ALL STEEL SHALL BE GALV. GALV.</p> <p>10. ALL STEEL SHALL BE GALV. GALV.</p>

SIGN AREA SUMMARY

CONCRETE FOUNDATION	10' x 10'
STEEL SIGN POST	10' x 10'
TOTAL SIGN AREA	10' x 10'

GENERAL NOTES

THE SIGNER SHALL BE RESPONSIBLE FOR THE DESIGN AND CONSTRUCTION OF THE SIGN. THE CONTRACTOR SHALL BE RESPONSIBLE FOR THE INSTALLATION OF THE SIGN. THE CONTRACTOR SHALL BE RESPONSIBLE FOR THE MAINTENANCE OF THE SIGN.

WALGREENS

PRODUCT TYPE

CERTIFICATION AND SEAL

UNITED INSULATED STRUCTURES CORP.

1000 W. 100th St. - Chicago, Illinois 60644

DATE: 10/10/10

SCALE: 1/4" = 1'-0"

PROJECT: WALGREENS SIGN

DESIGNER: [Name]

CHECKED: [Name]

APPROVED: [Name]

A5.1



2nd ATTEMPT AT INTRODUCTION

10/21/2015

Alderman **Raymond A. Lopez**
Ward # 15
City of Chicago
City Hall, Room 300
121 North LaSalle Street
Chicago, Illinois 60602

Re: An ordinance to use and maintain a portion of the public right-of-way for **one (1) occupation of space(s)** for **WALGREENS # 06641**, adjacent to the premises known as **1614 W. 47th St.**

Dear Alderman **Raymond A. Lopez**:

The applicant referenced above has requested the use of the public right-of-way for a **occupation of space(s)**. An ordinance has been prepared by the Department of Business Affairs and Consumer Protection – Small Business Center - Public Way Use Unit for presentation to the City Council. Because this request was made for properties located in your ward, as approved by you as per the attached, I respectfully request that you introduce the attached ordinance at the next City Council meeting.

If you have any questions regarding this ordinance, please contact Anthony Bertuca at (312) 744-5506.

Department of Business Affairs and Consumer Protection



City of Chicago



O2015-7752

Office of the City Clerk

Document Tracking Sheet

Meeting Date:	10/21/2015
Sponsor(s):	Lopez (15)
Type:	Ordinance
Title:	Grant(s) of privilege in public way for Walgreens No. 06641 - sign
Committee(s) Assignment:	Committee on Transportation and Public Way

ORDINANCE
WALGREENS # 06641
Acct. No. 147 - 75
Permit No. 1119481

Be It Ordained by the City Council of the City of Chicago:

SECTION 1. Permission and authority are hereby given and granted to WALGREENS # 06641, upon the terms and subject to the conditions of this ordinance to maintain and use one (1) sign(s) projecting over the public right-of-way attached to its premises known as 1614 W. 47th St..

Said sign structure(s) measures as follows; along W. 47th:

One (1) at eighteen (18) feet in length, one (1) foot in height and twenty (20) feet above grade level.

The location of said privilege shall be as shown on prints kept on file with the Department of Business Affairs and Consumer Protection and the Office of the City Clerk.

Said privilege shall be constructed in accordance with plans and specifications approved by the Department of Transportation (Division of Project Development) and Zoning Department - Signs.

This grant of privilege in the public way shall be subject to the provisions of Section 10-28-015 and all other required provisions of the Municipal Code of Chicago.

The grantee shall pay to the City of Chicago as compensation for the privilege #1119481 herein granted the sum of one hundred (\$100.00) per annum in advance.

A 25% penalty will be added for payments received after due date.

The permit holder agrees to hold the City of Chicago harmless for any damage, relocation or replacement costs associated with damage, relocation or removal of private property caused by the City performing work in the public way.

Authority herein given and granted for a period of five (5) years from and after 11/19/2013.

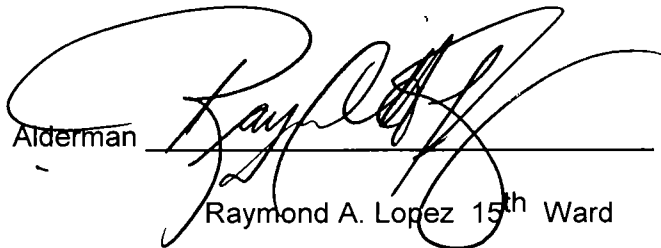
Alderman 
Raymond A. Lopez 15th Ward

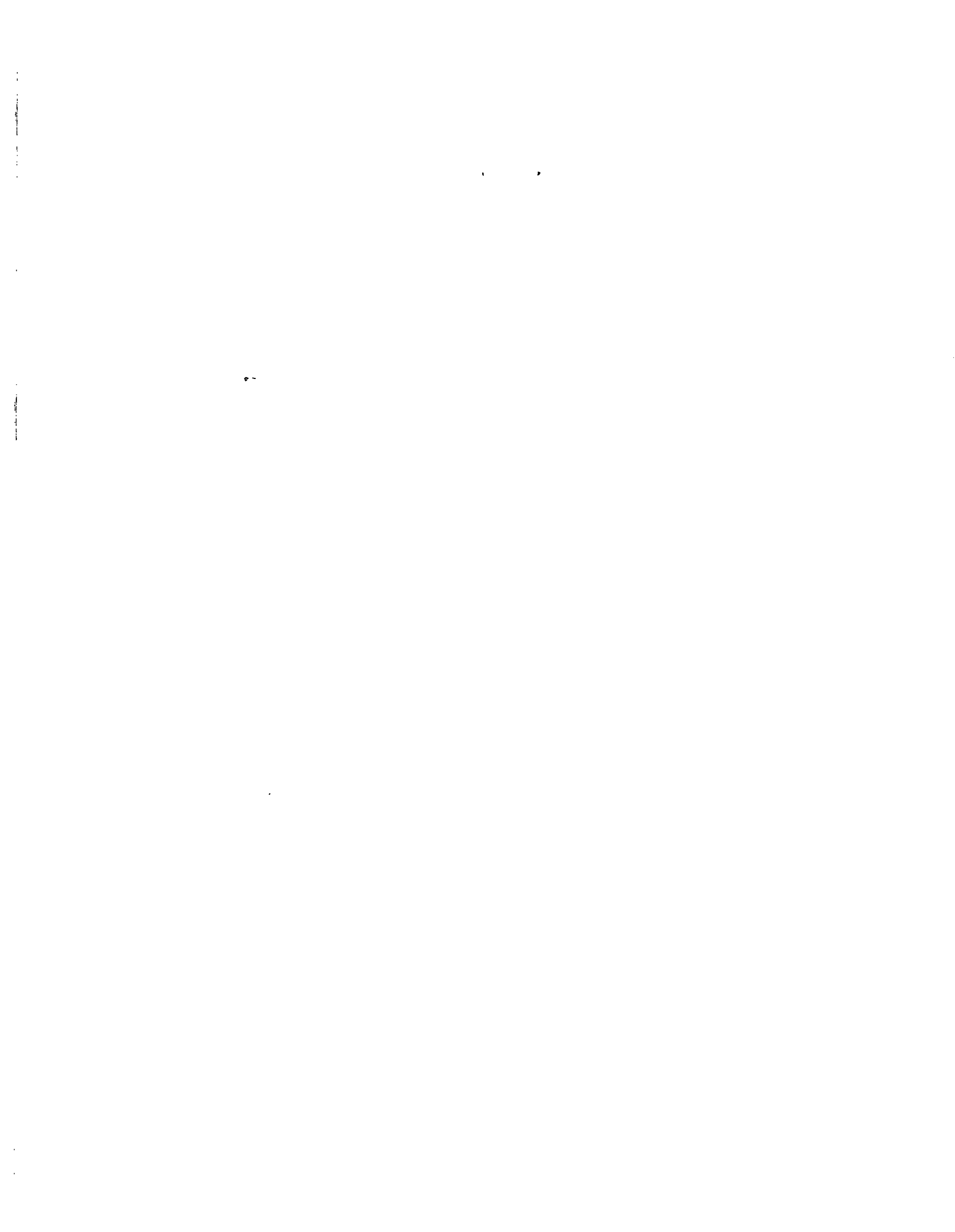

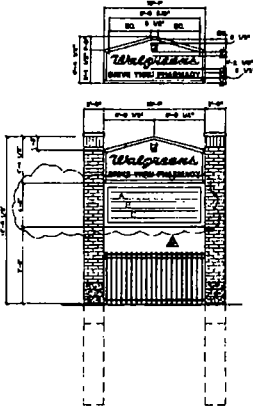

1 ELEVATION
1/4" = 1'-0"

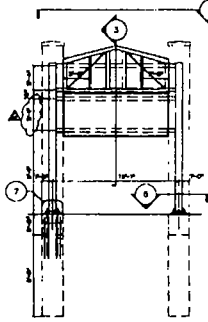

2 ELEVATION
1/4" = 1'-0"

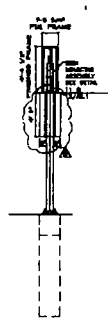

3 SECTION
1/4" = 1'-0"

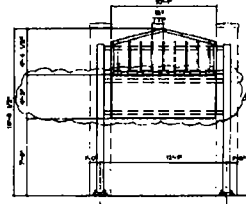

4 ELEVATION SIGN LIGHTING
1/4" = 1'-0"

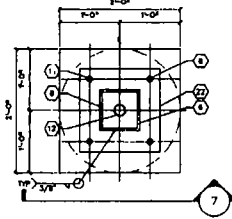

5 PLAN SECTION
1/4" = 1'-0"

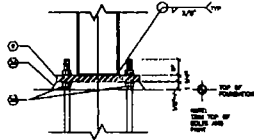

7 SECTION DETAIL
1/4" = 1'-0"

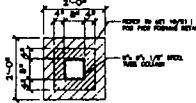

9 PIER FOR SIGN DETAIL
1/4" = 1'-0"

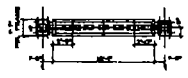

6 TOP VIEW SIGN
1/4" = 1'-0"

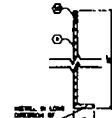

8 ANCHOR BOLT DETAIL
1/4" = 1'-0"

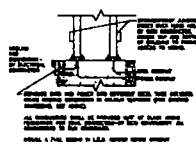

10 GROUNDING DETAIL
1/4" = 1'-0"

NOTE
THIS DRAWING IS ONLY
SHOWN FOR REFERENCE.
FINAL DESIGN OF SIGNAGE
AND STRUCTURE IS BY THE
SIGN CONTRACTOR

KEYED NOTES	
1) ANGLE OF 2" x 2" x 1/4" STEEL PLATE.	12) 1/4" DIA. WIRE BRACE BOLTS W/ 3/4" DIA. NUTS AND WASHERS.
2) ANGLE OF 2" x 2" x 1/4" STEEL PLATE.	13) 1/4" DIA. WIRE BRACE BOLTS W/ 3/4" DIA. NUTS AND WASHERS.
3) 1/2" DIA. WIRE BRACE BOLTS W/ 3/4" DIA. NUTS AND WASHERS.	14) 1/4" DIA. WIRE BRACE BOLTS W/ 3/4" DIA. NUTS AND WASHERS.
4) 1/2" DIA. WIRE BRACE BOLTS W/ 3/4" DIA. NUTS AND WASHERS.	15) 1/4" DIA. WIRE BRACE BOLTS W/ 3/4" DIA. NUTS AND WASHERS.
5) 1/2" DIA. WIRE BRACE BOLTS W/ 3/4" DIA. NUTS AND WASHERS.	16) 1/4" DIA. WIRE BRACE BOLTS W/ 3/4" DIA. NUTS AND WASHERS.
6) 1/2" DIA. WIRE BRACE BOLTS W/ 3/4" DIA. NUTS AND WASHERS.	17) 1/4" DIA. WIRE BRACE BOLTS W/ 3/4" DIA. NUTS AND WASHERS.
7) 1/2" DIA. WIRE BRACE BOLTS W/ 3/4" DIA. NUTS AND WASHERS.	18) 1/4" DIA. WIRE BRACE BOLTS W/ 3/4" DIA. NUTS AND WASHERS.
8) 1/2" DIA. WIRE BRACE BOLTS W/ 3/4" DIA. NUTS AND WASHERS.	19) 1/4" DIA. WIRE BRACE BOLTS W/ 3/4" DIA. NUTS AND WASHERS.
9) 1/2" DIA. WIRE BRACE BOLTS W/ 3/4" DIA. NUTS AND WASHERS.	20) 1/4" DIA. WIRE BRACE BOLTS W/ 3/4" DIA. NUTS AND WASHERS.
10) 1/2" DIA. WIRE BRACE BOLTS W/ 3/4" DIA. NUTS AND WASHERS.	21) 1/4" DIA. WIRE BRACE BOLTS W/ 3/4" DIA. NUTS AND WASHERS.
11) 1/2" DIA. WIRE BRACE BOLTS W/ 3/4" DIA. NUTS AND WASHERS.	22) 1/4" DIA. WIRE BRACE BOLTS W/ 3/4" DIA. NUTS AND WASHERS.

COLORS	STRUCTURAL GENERAL NOTES
1) ALL ALUMINUM SURFACES TO BE ANODIZED.	1) ALL ALUMINUM SURFACES TO BE ANODIZED.
2) ALL STRUCTURAL STEEL SHALL BE A36.	2) ALL STRUCTURAL STEEL SHALL BE A36.
3) ALL STRUCTURAL STEEL SHALL BE GALV. OR GALV. PAINTED.	3) ALL STRUCTURAL STEEL SHALL BE GALV. OR GALV. PAINTED.
4) ALL STEEL SHALL BE W/ 3/16" THICKNESS.	4) ALL STEEL SHALL BE W/ 3/16" THICKNESS.
5) ALL STEEL SHALL BE W/ 3/16" THICKNESS.	5) ALL STEEL SHALL BE W/ 3/16" THICKNESS.
6) ALL STEEL SHALL BE W/ 3/16" THICKNESS.	6) ALL STEEL SHALL BE W/ 3/16" THICKNESS.
7) ALL STEEL SHALL BE W/ 3/16" THICKNESS.	7) ALL STEEL SHALL BE W/ 3/16" THICKNESS.
8) ALL STEEL SHALL BE W/ 3/16" THICKNESS.	8) ALL STEEL SHALL BE W/ 3/16" THICKNESS.
9) ALL STEEL SHALL BE W/ 3/16" THICKNESS.	9) ALL STEEL SHALL BE W/ 3/16" THICKNESS.
10) ALL STEEL SHALL BE W/ 3/16" THICKNESS.	10) ALL STEEL SHALL BE W/ 3/16" THICKNESS.
11) ALL STEEL SHALL BE W/ 3/16" THICKNESS.	11) ALL STEEL SHALL BE W/ 3/16" THICKNESS.
12) ALL STEEL SHALL BE W/ 3/16" THICKNESS.	12) ALL STEEL SHALL BE W/ 3/16" THICKNESS.
13) ALL STEEL SHALL BE W/ 3/16" THICKNESS.	13) ALL STEEL SHALL BE W/ 3/16" THICKNESS.
14) ALL STEEL SHALL BE W/ 3/16" THICKNESS.	14) ALL STEEL SHALL BE W/ 3/16" THICKNESS.
15) ALL STEEL SHALL BE W/ 3/16" THICKNESS.	15) ALL STEEL SHALL BE W/ 3/16" THICKNESS.
16) ALL STEEL SHALL BE W/ 3/16" THICKNESS.	16) ALL STEEL SHALL BE W/ 3/16" THICKNESS.
17) ALL STEEL SHALL BE W/ 3/16" THICKNESS.	17) ALL STEEL SHALL BE W/ 3/16" THICKNESS.
18) ALL STEEL SHALL BE W/ 3/16" THICKNESS.	18) ALL STEEL SHALL BE W/ 3/16" THICKNESS.
19) ALL STEEL SHALL BE W/ 3/16" THICKNESS.	19) ALL STEEL SHALL BE W/ 3/16" THICKNESS.
20) ALL STEEL SHALL BE W/ 3/16" THICKNESS.	20) ALL STEEL SHALL BE W/ 3/16" THICKNESS.
21) ALL STEEL SHALL BE W/ 3/16" THICKNESS.	21) ALL STEEL SHALL BE W/ 3/16" THICKNESS.
22) ALL STEEL SHALL BE W/ 3/16" THICKNESS.	22) ALL STEEL SHALL BE W/ 3/16" THICKNESS.

SIGN AREA SUMMARY	
ROOF PANEL	21.12
ROOF BRACE PANEL	5.43
TOTAL SIGN AREA	26.55

GENERAL NOTES

THE SIGNAGE SHALL BE INSTALLED AS SHOWN IN THE DRAWINGS. THE CONTRACTOR SHALL BE RESPONSIBLE FOR THE PROTECTION OF ALL UTILITIES AND STRUCTURES EXISTING ON THE SITE. THE SIGNAGE SHALL BE INSTALLED AS SHOWN IN THE DRAWINGS. THE CONTRACTOR SHALL BE RESPONSIBLE FOR THE PROTECTION OF ALL UTILITIES AND STRUCTURES EXISTING ON THE SITE.

NOTES

THIS DRAWING IS ONLY SHOWN FOR REFERENCE. FINAL DESIGN OF SIGNAGE AND STRUCTURE IS BY THE SIGN CONTRACTOR.

WALGREENS

PROJECT TYPE

CERTIFICATION AND SEAL

UNITED INSULATED STRUCTURES CORP.

WALGREENS - GREENS ASSOCIATES

A5.1



2nd ATTEMPT AT INTRODUCTION

10/21/2015

Alderman **Raymond A. Lopez**
Ward # 15
City of Chicago City Hall, Room 300
121 North LaSalle Street
Chicago, Illinois 60602

Re: An ordinance to use and maintain a portion of the public right-of-way for **one (1) sign(s)** for
WALGREENS # 06641, adjacent to the premises known as **1614 W. 47th St.**

Dear Alderman **Raymond A. Lopez**:

The applicant referenced above has requested the use of the public right-of-way for a **sign(s)**. An ordinance has been prepared by the Department of Business Affairs and Consumer Protection – Small Business Center - Public Way Use Unit for presentation to the City Council. Because this request was made for properties located in your ward, as approved by you as per the attached, I respectfully request that you introduce the attached ordinance at the next City Council meeting.

If you have any questions regarding this ordinance, please contact Anthony Bertuca at (312) 744-5506.

Department of Business Affairs and Consumer Protection



City of Chicago



O2015-7753

Office of the City Clerk

Document Tracking Sheet

Meeting Date:	10/21/2015
Sponsor(s):	Cochran (20)
Type:	Ordinance
Title:	Grant(s) of privilege in public way for University of Chicago (File No. 30)
Committee(s) Assignment:	Committee on Transportation and Public Way

ORDINANCE
UNIVERSITY OF CHGO FILE #30
Acct. No 43697 - 14
Permit No 1118284

Be It Ordained by the City Council of the City of Chicago:

SECTION 1. Permission and authority are hereby given and granted to UNIVERSITY OF CHGO FILE #30, upon the terms and subject to the conditions of this ordinance to maintain and use, as now constructed, Steam service pipes consisting of one (1) six (6) inch high pressure steam main one (1) three (3) inch high pressure drip main beginning at an existing steam service manhole located under the sidewalk on the west side of the south curb line of east 60th Street, thence running south under sidewalk entering a manhole, the south of wall of said manhole is at appoint approximately one hundred ninety-six (196) feet, south of south curb line of East 60th Street Lines(s) under the public right-of-way adjacent to its premises known as 6000 S. Ingleside Ave..

Said Steam Lines(s) at S. Ingleside Avenue measure(s):

One (1) at one hundred ninety-six point five (196.5) feet in length, and one (1) foot in width for a total of one hundred ninety-six point five (196.5) square feet.

The location of said privilege shall be as shown on prints kept on file with the Department of Business Affairs and Consumer Protection and the Office of the City Clerk.

Said privilege shall be constructed in accordance with plans and specifications approved by the Department of Transportation (Office of Underground Coordination) and Department of Water Management.

This grant of privilege in the public way shall be subject to the provisions of Section 10-28-015 and all other required provisions of the Municipal Code of Chicago.

The grantee shall pay to the City of Chicago as compensation for the privilege #1118284 herein granted the sum of four hundred (\$400.00) per annum in advance.

A 25% penalty will be added for payments received after due date.

The permit holder agrees to hold the City of Chicago harmless for any damage, relocation or replacement costs associated with damage, relocation or removal of private property caused by the City performing work in the public way.

Authority herein given and granted for a period of five (5) years from and after 11/28/2014.

Alderman

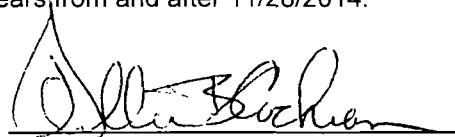

Willie Cochran 20th Ward

N
→

60TH ST

AV

Steam line

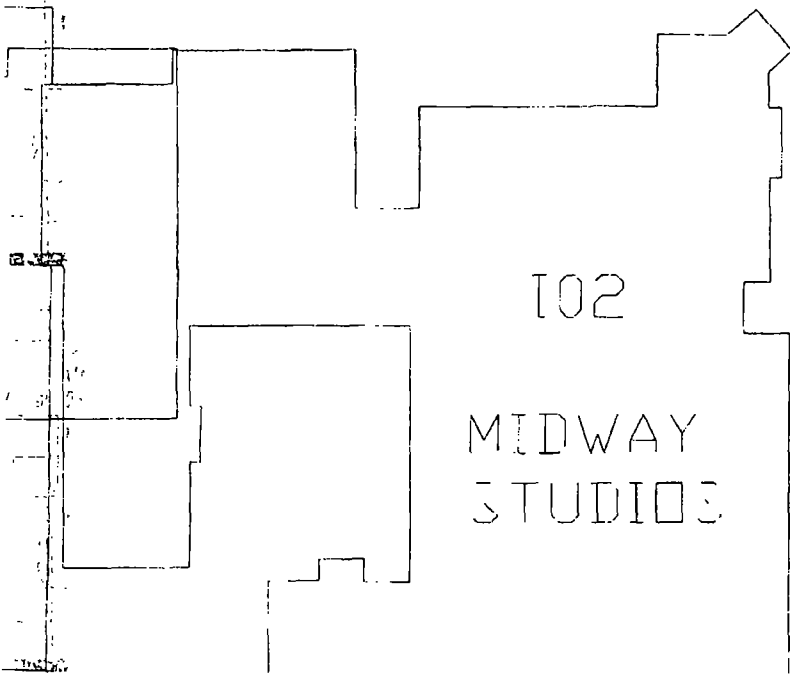

S INGLESIDE

FACUA



Department of Business Affairs and Consumer Protection
Small Business Center - Public Way Use Unit
City Hall - 121 N LaSalle Street, Room 800 • Chicago, IL 60602
312-74-GOBIZ / 312-744-6249 • (312) 744-1944 (TTY)
<http://www.cityofchicago.org/bacp>

2nd ATTEMPT AT INTRODUCTION

10/21/2015

Alderman **Willie Cochran**
Ward # **20**
City of Chicago
City Hall, Room **300**
121 North LaSalle Street
Chicago, Illinois 60602

Re: An ordinance to use and maintain a portion of the public right-of-way for **one (1) steam lines(s)** for **UNIVERSITY OF CHGO FILE #30**, adjacent to the premises known as **6000 S. Ingleside Ave.**.

Dear Alderman **Willie Cochran**:

The applicant referenced above has requested the use of the public right-of-way for a **steam lines(s)**. An ordinance has been prepared by the Department of Business Affairs and Consumer Protection – Small Business Center - Public Way Use Unit for presentation to the City Council. Because this request was made for properties located in your ward, as approved by you as per the attached, I respectfully request that you introduce the attached ordinance at the next City Council meeting.

If you have any questions regarding this ordinance, please contact Anthony Bertuca at (312) 744-5506.

Department of Business Affairs and Consumer Protection



City of Chicago



O2015-7754

Office of the City Clerk

Document Tracking Sheet

Meeting Date:	10/21/2015
Sponsor(s):	Zalewski (23)
Type:	Ordinance
Title:	Grant(s) of privilege in public way for Walgreens No. 2711
Committee(s) Assignment:	Committee on Transportation and Public Way

ORDINANCE
WALGREENS #2711
Acct. No. 7551 - 38
Permit No. 1119552

Be It Ordained by the City Council of the City of Chicago:

SECTION 1. Permission and authority are hereby given and granted to WALGREENS #2711, upon the terms and subject to the conditions of this ordinance to maintain and use three (3) sign(s) projecting over the public right-of-way attached to its premises known as 7150 W. Archer Ave..

Said sign structure(s) measures as follows; along S. Harlem:

One (1) at twenty-six point six six (26.66) feet in length, two point eight three (2.83) feet in height and eighteen (18) feet above grade level.

Said sign structure(s) measures as follows; along S. Harlem:

One (1) at fourteen (14) feet in length, one point five (1.5) feet in height and fourteen (14) feet above grade level.

Said sign structure(s) measures as follows; along S. Harlem:

One (1) at twelve point eight three (12.83) feet in length, one point five (1.5) feet in height and fourteen (14) feet above grade level.

The location of said privilege shall be as shown on prints kept on file with the Department of Business Affairs and Consumer Protection and the Office of the City Clerk.

Said privilege shall be constructed in accordance with plans and specifications approved by the Department of Transportation (Division of Project Development) and Zoning Department - Signs.

This grant of privilege in the public way shall be subject to the provisions of Section 10-28-015 and all other required provisions of the Municipal Code of Chicago.

The grantee shall pay to the City of Chicago as compensation for the privilege #1119552 herein granted the sum of four hundred seventy-five (\$475.00) per annum in advance.

A 25% penalty will be added for payments received after due date.

The permit holder agrees to hold the City of Chicago harmless for any damage, relocation or replacement costs associated with damage, relocation or removal of private property caused by the City performing work in the public way.

Authority herein given and granted for a period of five (5) years from and after 05/13/2014.

Alderman

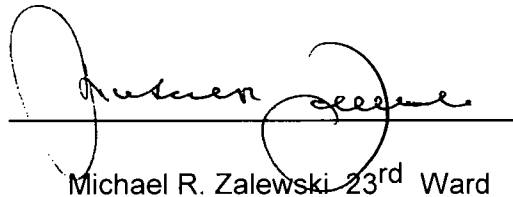

Michael R. Zalewski 23rd Ward

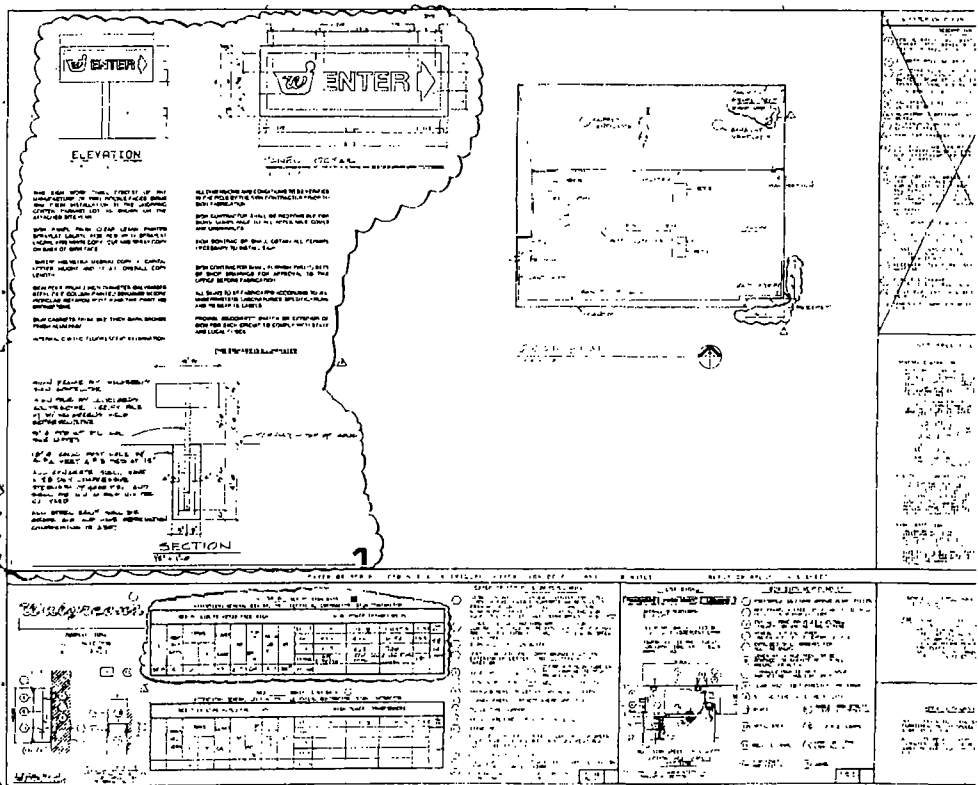



Department of Business Affairs and Consumer Protection
Small Business Center - Public Way Use Unit
City Hall - 121 N LaSalle Street, Room 800 • Chicago, IL 60602
312-74-GOBIZ / 312-744-6249 • (312) 744-1944 (TTY)
<http://www.cityofchicago.org/bacp>

2nd ATTEMPT AT INTRODUCTION

10/21/2015

Alderman **Michael R. Zalewski**
Ward # **23**
City of Chicago
City Hall, Room **200**
121 North LaSalle Street
Chicago, Illinois 60602

Re: An ordinance to use and maintain a portion of the public right-of-way for **three (3) sign(s)** for
WALGREENS #2711, adjacent to the premises known as **7150 W. Archer Ave.**.

Dear Alderman **Michael R. Zalewski**:

The applicant referenced above has requested the use of the public right-of-way for a **sign(s)**. An ordinance has been prepared by the Department of Business Affairs and Consumer Protection -- Small Business Center - Public Way Use Unit for presentation to the City Council. Because this request was made for properties located in your ward, as approved by you as per the attached, I respectfully request that you introduce the attached ordinance at the next City Council meeting.

If you have any questions regarding this ordinance, please contact Anthony Bertuca at (312) 744-5506.

Department of Business Affairs and Consumer Protection



City of Chicago



O2015-7756

Office of the City Clerk

Document Tracking Sheet

Meeting Date:	10/21/2015
Sponsor(s):	Maldonado (26)
Type:	Ordinance
Title:	Grant(s) of privilege in public way for Clipper/CC Ferns, The
Committee(s) Assignment:	Committee on Transportation and Public Way

ORDINANCE
THE CLIPPER/ CC FERNS
Acct. No. 65013 - 1
Permit No. 1120394

Be It Ordained by the City Council of the City of Chicago.

SECTION 1. Permission and authority are hereby given and granted to THE CLIPPER/ CC FERNS, upon the terms and subject to the conditions of this ordinance to construct, install, maintain and use one (1) Wind Screen(s) on the public right-of-way adjacent to its premises known as 1002 N California Ave..

Said Wind Screen(s) at W. Augusta measure(s):

One (1) at six (6) feet in length, and thirteen (13) feet in width for a total of seventy-eight (78) square feet.

The location of said privilege shall be as shown on prints kept on file with the Department of Business Affairs and Consumer Protection and the Office of the City Clerk.

Said privilege shall be constructed in accordance with plans and specifications approved by the Department of Transportation (Division of Project Development).

This grant of privilege in the public way shall be subject to the provisions of Section 10-28-015 and all other required provisions of the Municipal Code of Chicago.

The grantee shall pay to the City of Chicago as compensation for the privilege #1120394 herein granted the sum of four hundred (\$400.00) per annum in advance.

A 25% penalty will be added for payments received after due date

The permit holder agrees to hold the City of Chicago harmless for any damage, relocation or replacement costs associated with damage, relocation or removal of private property caused by the City performing work in the public way.

Authority herein given and granted for a period of five (5) years from and after Date of Passage.

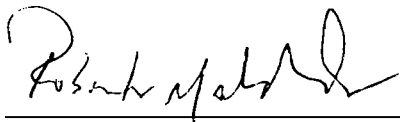
Alderman  _____

Roberto Maldonado 26th Ward

The California Clipper Corp.
DBA C.C. Ferns
1002 N. California Ave
Chicago, IL 60622

W. AUGUSTA BLVD.

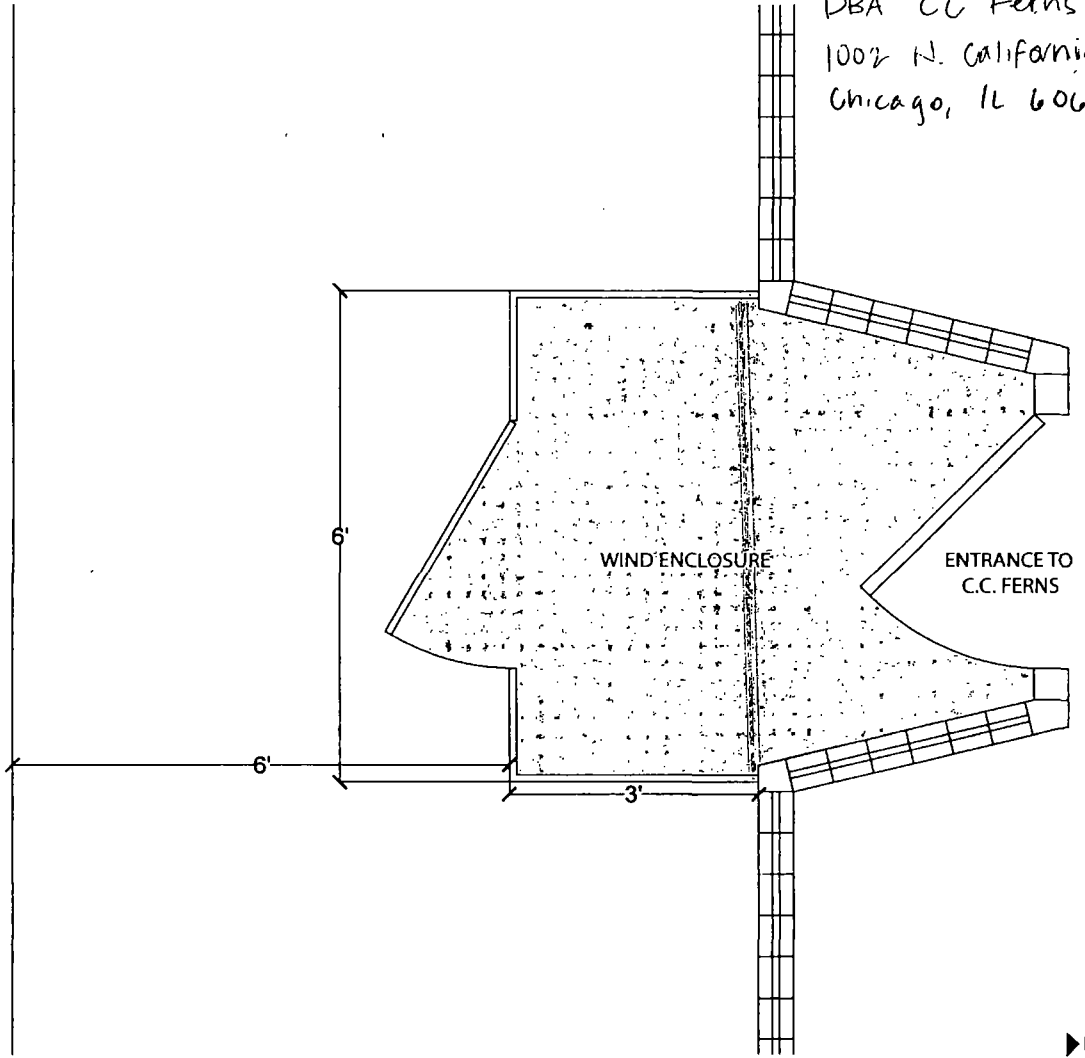

► N



10/21/2015

Alderman **Roberto Maldonado**
Ward # 26
City of Chicago
City Hall, Room 300
121 North LaSalle Street
Chicago, Illinois 60602

Re: An ordinance to use and maintain a portion of the public right-of-way for **one (1) wind screen(s)** for **THE CLIPPER/ CC FERNS**, adjacent to the premises known as **1002 N. California Ave.**.

Dear Alderman **Roberto Maldonado**:

The applicant referenced above has requested the use of the public right-of-way for a **wind screen(s)**. An ordinance has been prepared by the Department of Business Affairs and Consumer Protection – Small Business Center - Public Way Use Unit for presentation to the City Council. Because this request was made for properties located in your ward, as approved by you as per the attached, I respectfully request that you introduce the attached ordinance at the next City Council meeting.

If you have any questions regarding this ordinance, please contact Anthony Bertuca at (312) 744-5506.

Department of Business Affairs and Consumer Protection



City of Chicago



O2015-7757

Office of the City Clerk

Document Tracking Sheet

Meeting Date:	10/21/2015
Sponsor(s):	Burnett (27)
Type:	Ordinance
Title:	Grant(s) of privilege in public way for Grand Cafe
Committee(s) Assignment:	Committee on Transportation and Public Way

ORDINANCE
GRAND CAFE
Acct. No. 335358 - 1
Permit No. 1120368

Be It Ordained by the City Council of the City of Chicago:

SECTION 1. Permission and authority are hereby given and granted to GRAND CAFE, upon the terms and subject to the conditions of this ordinance to maintain and use, as now constructed, one (1) Exhaust Duct(s) projecting over the public right-of-way adjacent to its premises known as 2427 W Hubbard St..

Said Exhaust Duct(s) at N. ATRESIAN AVENUE measure(s):

One (1) at one point three three (1.33) foot in length, and one point three three (1.33) foot in width for a total of one point seven seven (1.77) square feet. Existing exhaust duct is approximately eleven (11) feet above grade level.

The location of said privilege shall be as shown on prints kept on file with the Department of Business Affairs and Consumer Protection and the Office of the City Clerk.

Said privilege shall be constructed in accordance with plans and specifications approved by the Department of Transportation (Division of Project Development) and Department of Transportation (Office of Underground Coordination).

This grant of privilege in the public way shall be subject to the provisions of Section 10-28-015 and all other required provisions of the Municipal Code of Chicago.

The grantee shall pay to the City of Chicago as compensation for the privilege #1120368 herein granted the sum of four hundred (\$400.00) per annum in advance.

A 25% penalty will be added for payments received after due date.

The permit holder agrees to hold the City of Chicago harmless for any damage, relocation or replacement costs associated with damage, relocation or removal of private property caused by the City performing work in the public way.

Authority herein given and granted for a period of five (5) years from and after 11/19/2013.

Alderman

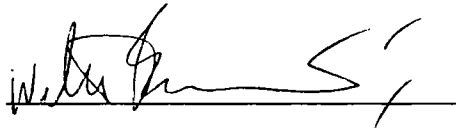

Walter Burnett Jr. 27th Ward

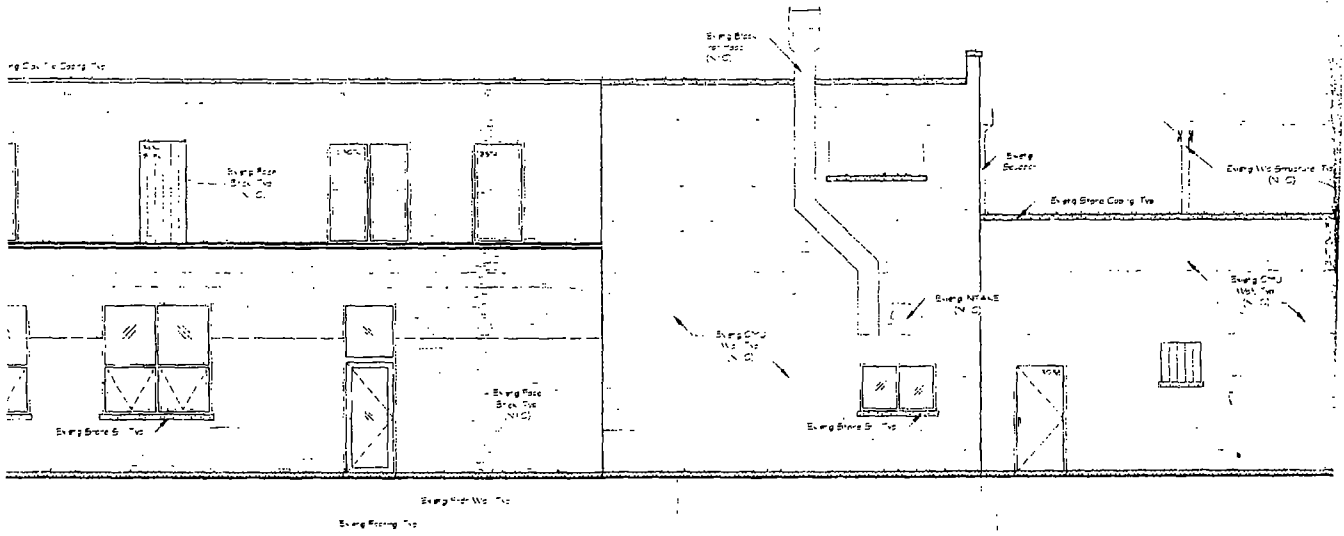

WEST ELEVATION - FOR REFERENCE ONLY

SCALE 3/4" = 1'-0"



City of Chicago



O2015-7758

Office of the City Clerk

Document Tracking Sheet

Meeting Date:	10/21/2015
Sponsor(s):	Ervin (28)
Type:	Ordinance
Title:	Grant(s) of privilege in public way for Ogden North LLC
Committee(s) Assignment:	Committee on Transportation and Public Way

ORDINANCE
Ogden North LLC
Acct No. 350716 - 1
Permit No. 1119018

Be It Ordained by the City Council of the City of Chicago:

SECTION 1. Permission and authority are hereby given and granted to Ogden North LLC, upon the terms and subject to the conditions of this ordinance to maintain and use, as now constructed, one (1) Fence(s) on the public right-of-way adjacent to its premises known as 1262-1300 S. Washtenaw Ave.

Said Fence(s) at 1262-1300 S WASHTENAW AVENUE measure(s)
One (1) fifty-five point five six (55.56) feet in length and approximately six (6) feet in height.

The location of said privilege shall be as shown on prints kept on file with the Department of Business Affairs and Consumer Protection and the Office of the City Clerk.

Said privilege shall be constructed in accordance with plans and specifications approved by the Department of Transportation (Division of Project Development).

This grant of privilege in the public way shall be subject to the provisions of Section 10-28-015 and all other required provisions of the Municipal Code of Chicago

The grantee shall pay to the City of Chicago as compensation for the privilege #1119018 herein granted the sum of four hundred (\$400 00) per annum in advance.

A 25% penalty will be added for payments received after due date

The permit holder agrees to hold the City of Chicago harmless for any damage, relocation or replacement costs associated with damage, relocation or removal of private property caused by the City performing work in the public way

Authority herein given and granted for a period of five (5) years from and after 05/12/2016.

Alderman



Jason Ervin 28th Ward

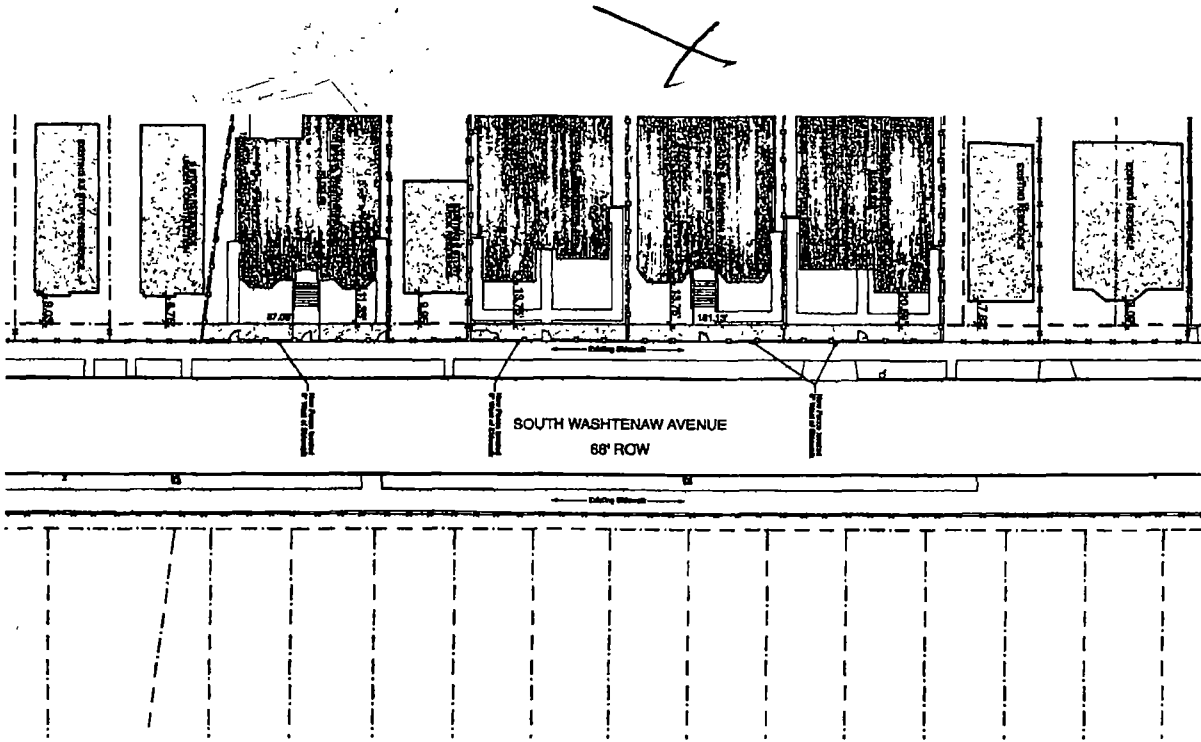

SOUTH WASHTENAW AVENUE
68' ROW

Property Line	-----
Building Footing	-----
Year of High Frame	-----
Owner's Handwritten Address	-----
Year of Encroachment in the Public Way	-----

Ogden North
Ogden and California
Chicago, Illinois
Buildings & Pl. N. A. & B.
Scale: 1/4"=1'-0"
Date: 11/11/11

East Ogden, LLC
Chicago, Illinois

Encroachments Within
the Public Way

KOD
KOD Associates, LLC
11111 1st Street
Suite 100
Ogden, UT 84403
PH: 438-2345



11/11/11
11/11/11
11/11/11



City of Chicago



O2015-7760

Office of the City Clerk

Document Tracking Sheet

Meeting Date:	10/21/2015
Sponsor(s):	Austin (34)
Type:	Ordinance
Title:	Grant(s) of privilege in public way for Acceptance Insurance
Committee(s) Assignment:	Committee on Transportation and Public Way

ORDINANCE
ACCEPTANCE INSURANCE
Acct. No. 398912 - 5
Permit No. 1119117

Be It Ordained by the City Council of the City of Chicago:

SECTION 1. Permission and authority are hereby given and granted to ACCEPTANCE INSURANCE, upon the terms and subject to the conditions of this ordinance to maintain and use one (1) sign(s) projecting over the public right-of-way attached to its premises known as 11109 S. Halsted St..

Said sign structure(s) measures as follows; along S HALSTED ST:

One (1) at fifteen point eight three (15.83) feet in length, three (3) feet in height and twelve (12) feet above grade level.

The location of said privilege shall be as shown on prints kept on file with the Department of Business Affairs and Consumer Protection and the Office of the City Clerk.

Said privilege shall be constructed in accordance with plans and specifications approved by the Department of Transportation (Division of Project Development) and Zoning Department - Signs.

This grant of privilege in the public way shall be subject to the provisions of Section 10-28-015 and all other required provisions of the Municipal Code of Chicago.

The grantee shall pay to the City of Chicago as compensation for the privilege #1119117 herein granted the sum of three hundred (\$300.00) per annum in advance.

A 25% penalty will be added for payments received after due date.

The permit holder agrees to hold the City of Chicago harmless for any damage, relocation or replacement costs associated with damage, relocation or removal of private property caused by the City performing work in the public way.

Authority herein given and granted for a period of five (5) years from and after Date of Passage.

Alderman

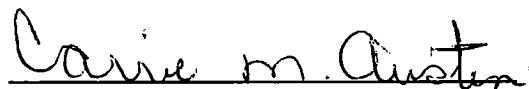

Carrie M. Austin 34th Ward



36" Internally Illuminated Raceway Mounted Channel Letter Set

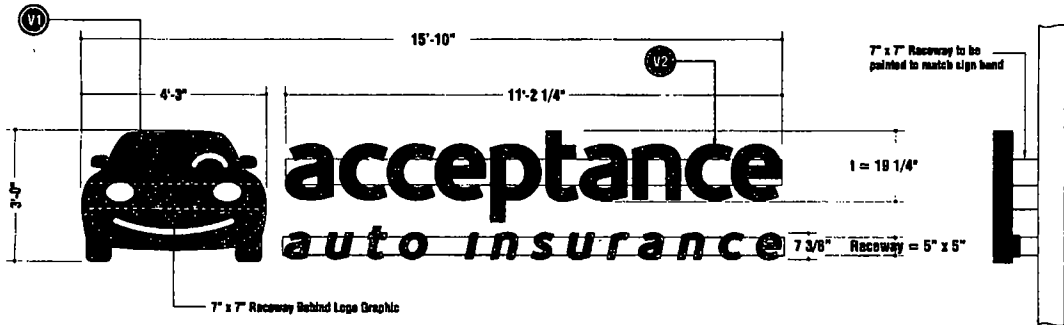

General Description

Car Logo will be a Free Form Can Sign, fabricated like a large single channel letter with aluminum returns and back, trim cap, white acrylic faces decorated with 3M Vinyl graphics 1st surface illumination to be white L E D 's Taglines to be a typical LED Letterset all on Raceways

Color Schedule

3M Vinyl Specifications

- V1 PMS #362c - Green
3M 3630-156 Vivid Green
- V2 PMS #2745c - Purple
3M 3630-67 Royal Blue

Color Schedule

Paint Specifications

- Painted Black (Returns)
- Mounted Raceway (Paint to match Warm Gray 1c)

"ACCEPTANCE" LED Face LH Letter Mounted on (Raceway)

1	ALUMINUM LED 7 CHANNEL	ALUMINUM BODY
2	FRONT BODY	FRONT BODY
3	FRONT FACE	FRONT FACE
4	FRONT TRIM	FRONT TRIM
5	FRONT CAP	FRONT CAP
6	FRONT TRIM	FRONT TRIM
7	FRONT TRIM	FRONT TRIM
8	FRONT TRIM	FRONT TRIM
9	FRONT TRIM	FRONT TRIM
10	FRONT TRIM	FRONT TRIM
11	FRONT TRIM	FRONT TRIM
12	FRONT TRIM	FRONT TRIM

*LEDS ARE NOT TO BE USED IN THIS APPLICATION
*ALL LETTER PRODUCT IS MADE IN U.S.A.
*ALL ELECTRICAL WIRING MUST BE DONE BY A QUALIFIED ELECTRICIAN

"AUTO INSURANCE" LED Face LH Letter Mounted on (Raceway)

1	ALUMINUM LED 7 CHANNEL	ALUMINUM BODY
2	FRONT BODY	FRONT BODY
3	FRONT FACE	FRONT FACE
4	FRONT TRIM	FRONT TRIM
5	FRONT CAP	FRONT CAP
6	FRONT TRIM	FRONT TRIM
7	FRONT TRIM	FRONT TRIM
8	FRONT TRIM	FRONT TRIM
9	FRONT TRIM	FRONT TRIM
10	FRONT TRIM	FRONT TRIM
11	FRONT TRIM	FRONT TRIM
12	FRONT TRIM	FRONT TRIM

*LEDS ARE NOT TO BE USED IN THIS APPLICATION
*ALL LETTER PRODUCT IS MADE IN U.S.A.
*ALL ELECTRICAL WIRING MUST BE DONE BY A QUALIFIED ELECTRICIAN

SQUARE FEET 47.50

SCALE: 1/2" = 1'-0"



2015 2016 2017 2018 2019 2020 2021 2022 2023 2024 2025 2026 2027 2028 2029 2030 2031 2032 2033 2034 2035 2036 2037 2038 2039 2040 2041 2042 2043 2044 2045 2046 2047 2048 2049 2050 2051 2052 2053 2054 2055 2056 2057 2058 2059 2060 2061 2062 2063 2064 2065 2066 2067 2068 2069 2070 2071 2072 2073 2074 2075 2076 2077 2078 2079 2080 2081 2082 2083 2084 2085 2086 2087 2088 2089 2090 2091 2092 2093 2094 2095 2096 2097 2098 2099 2100

CUSTOMER: Acceptance Insurance
 LOCATION: Store #448 - Chicago, IL
 SALESMAN: SM ORGANIZER JHR
 DATE: 02/04/18



PRODUCTION PROCESSING
 Job # _____
 001 _____
 002 _____
 003 _____
 004 _____

INITIALS: _____
 DATE: _____
 REVIEWER: _____

B68230A



2nd ATTEMPT AT INTRODUCTION

10/21/2015

Alderman **Carrie M. Austin**
Ward # **34**
City of Chicago
City Hall, Room **200**
121 North LaSalle Street
Chicago, Illinois 60602

Re: An ordinance to use and maintain a portion of the public right-of-way for **one (1) sign(s)** for **ACCEPTANCE INSURANCE**, adjacent to the premises known as **11109 S. Halsted St.**

Dear Alderman **Carrie M. Austin**:

The applicant referenced above has requested the use of the public right-of-way for a **sign(s)**. An ordinance has been prepared by the Department of Business Affairs and Consumer Protection – Small Business Center - Public Way Use Unit for presentation to the City Council. Because this request was made for properties located in your ward, as approved by you as per the attached, I respectfully request that you introduce the attached ordinance at the next City Council meeting.

If you have any questions regarding this ordinance, please contact Anthony Bertuca at (312) 744-5506.

Department of Business Affairs and Consumer Protection



City of Chicago



O2015-7763

Office of the City Clerk

Document Tracking Sheet

Meeting Date:	10/21/2015
Sponsor(s):	Ramirez-Rosa (35)
Type:	Ordinance
Title:	Grant(s) of privilege in public way for Black Tie Formalwear
Committee(s) Assignment:	Committee on Transportation and Public Way

ORDINANCE
BLACK TIE FORMALWEAR
Acct. No. 272765 - 1
Permit No. 1120397

Be It Ordained by the City Council of the City of Chicago:

SECTION 1. Permission and authority are hereby given and granted to BLACK TIE FORMALWEAR, upon the terms and subject to the conditions of this ordinance to maintain and use one (1) sign(s) projecting over the public right-of-way attached to its premises known as 3534 W. Irving Park Rd..

Said sign structure(s) measures as follows; along W. Irving Park:
One (1) at eight (8) feet in length, three (3) feet in height and nine (9) feet above grade level.

The location of said privilege shall be as shown on prints kept on file with the Department of Business Affairs and Consumer Protection and the Office of the City Clerk.

Said privilege shall be constructed in accordance with plans and specifications approved by the Department of Transportation (Division of Project Development) and Zoning Department - Signs.

This grant of privilege in the public way shall be subject to the provisions of Section 10-28-015 and all other required provisions of the Municipal Code of Chicago.

The grantee shall pay to the City of Chicago as compensation for the privilege #1120397 herein granted the sum of one hundred (\$100.00) per annum in advance.

A 25% penalty will be added for payments received after due date.

The permit holder agrees to hold the City of Chicago harmless for any damage, relocation or replacement costs associated with damage, relocation or removal of private property caused by the City performing work in the public way.

Authority herein given and granted for a period of five (5) years from and after 07/30/2013.

Alderman  35

Carlos Ramirez-Rosa 35th Ward



Hwangso Sign & Design Inc.
www.3hwangso.com
3hwangso@gmail.com
8526 W. Golf Rd #Q Niles, IL 60714

Drawing Date 6/19/2015
Drawing Name Catholic Biblical Book Store
Company Catholic Biblical Book Store
Address . 5525 W Belmont
State :IL

City Chicago
Phone 547-962-7556

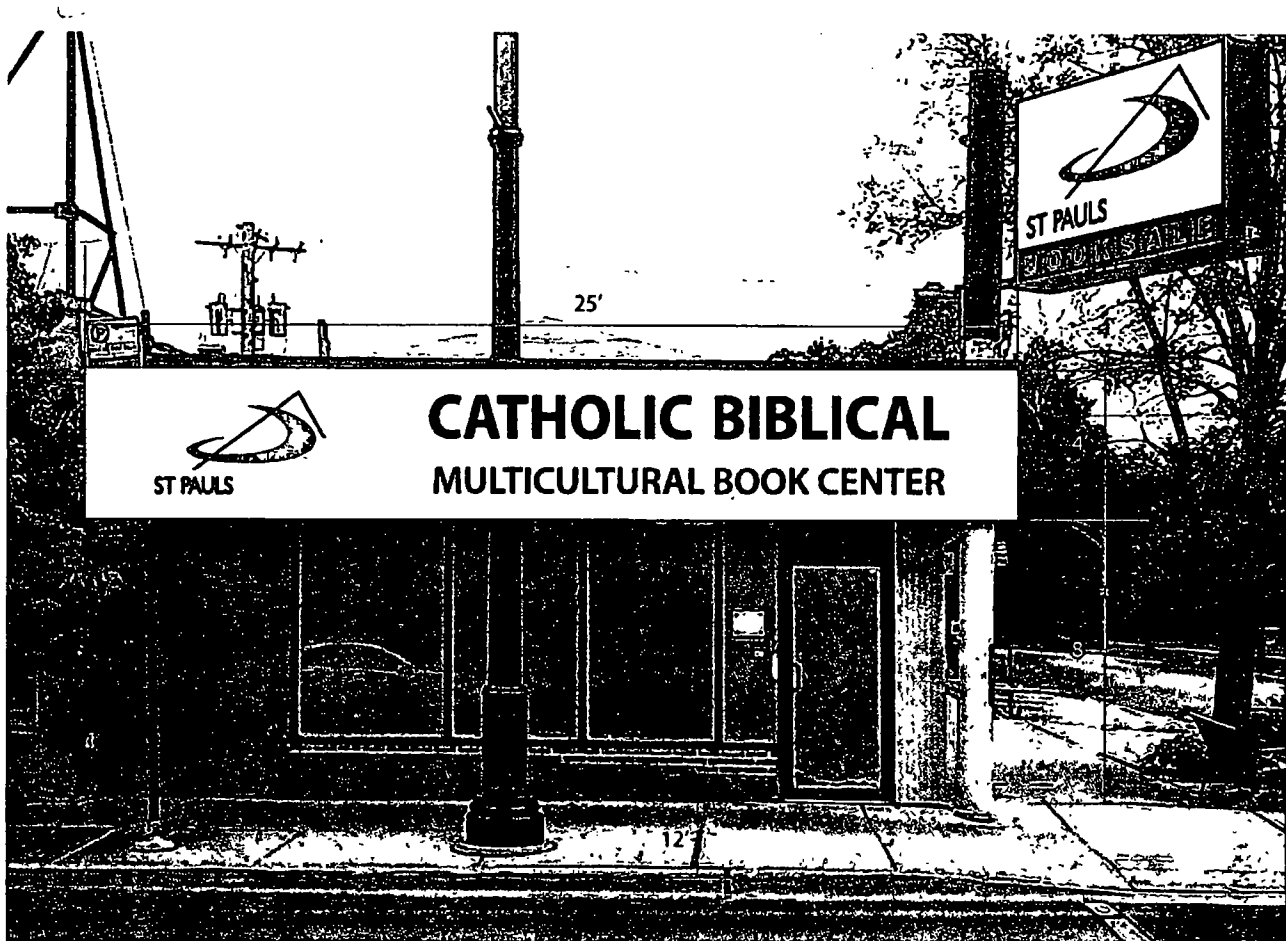

Non-Illuminated
T : 1" Routed letters (Black Sintra PVC Board)
25ft x 4ft (300"x48") Scale : 10/100

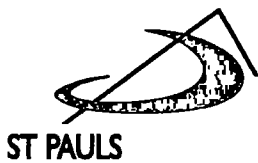

**CATHOLIC BIBLICAL
MULTICULTURAL BOOK CENTER**

Customer Approval Signature

Date

Landlord Approval

Date

Please review the following COLORS, LAYOUT, LOGOS, SIZES and DESIGN IDEAS You signature AUTHORIZES HWANGSO SIGN & DESIGN Inc To Manufacture items as shown above



City of Chicago



O2015-7765

Office of the City Clerk

Document Tracking Sheet

Meeting Date: 10/21/2015
Sponsor(s): Villegas (36)
Type: Ordinance
Title: Grant(s) of privilege in public way for Healthcare Alternatives
Committee(s) Assignment: Committee on Transportation and Public Way

ORDINANCE
HEALTHCARE ALTERNATIVES
Acct. No. 86733 - 6
Permit No. 1119400

Be It Ordained by the City Council of the City of Chicago:

SECTION 1. Permission and authority are hereby given and granted to HEALTHCARE ALTERNATIVES, upon the terms and subject to the conditions of this ordinance to construct, install, maintain and use one (1) Handicap Ramp on the public right-of-way adjacent to its premises known as 5005 W. Fullerton Ave..

Said Handicap Ramp at W. Fullerton Avenue measure(s):

One (1) at thirty-two point two five (32.25) feet in length, and four point three three (4.33) feet in width for a total of one hundred thirty-nine point six four (139.64) square feet. Said handicap ramp shall have hand railing.

The location of said privilege shall be as shown on prints kept on file with the Department of Business Affairs and Consumer Protection and the Office of the City Clerk.

Said privilege shall be constructed in accordance with plans and specifications approved by the Department of Transportation (Division of Project Development) and Mayor's Office for People with Disabilities.

This grant of privilege in the public way shall be subject to the provisions of Section 10-28-015 and all other required provisions of the Municipal Code of Chicago.

The grantee shall pay to the City of Chicago as compensation for the privilege #1119400 herein granted the sum of four hundred (\$400.00) per annum in advance.

A 25% penalty will be added for payments received after due date.

The permit holder agrees to hold the City of Chicago harmless for any damage, relocation or replacement costs associated with damage, relocation or removal of private property caused by the City performing work in the public way.

Authority herein given and granted for a period of five (5) years from and after Date of Passage.

Alderman  _____
Gilbert Villegas 36th Ward

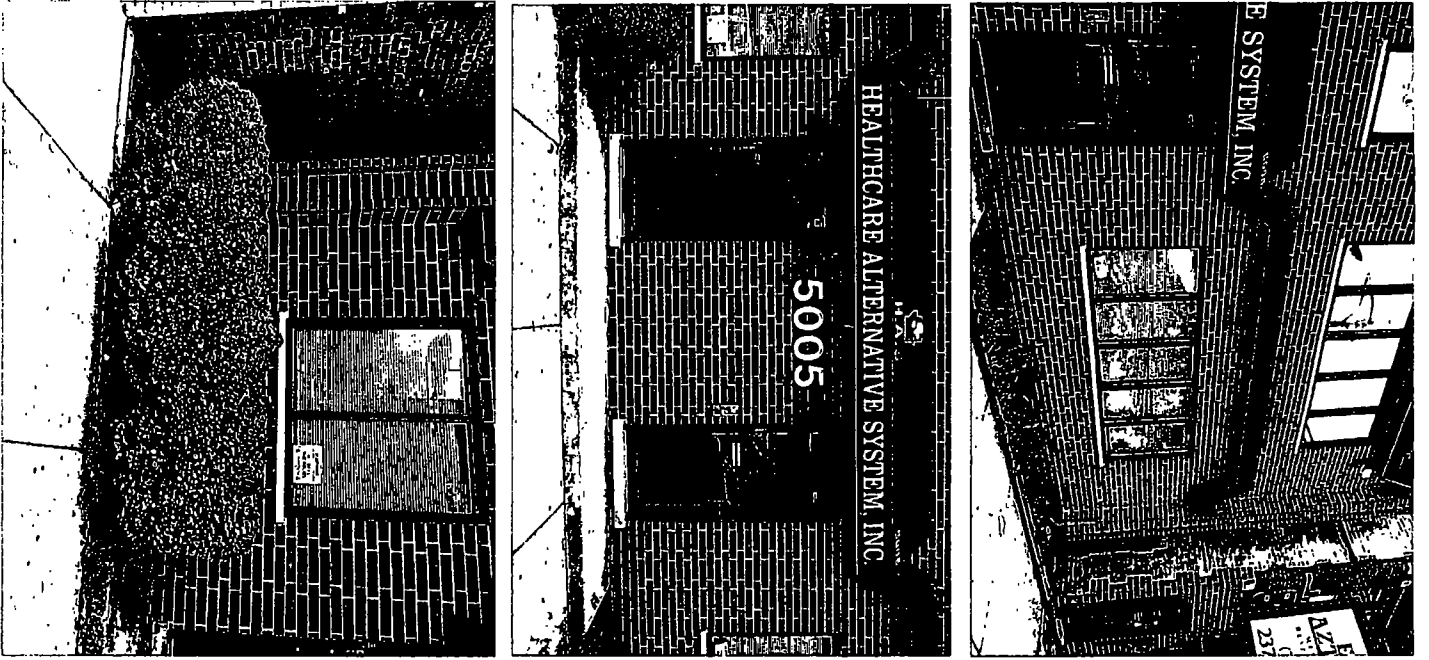

APPLICATION TO USE THE PUBLIC RIGHT OF WAY
5005 W FULLERTON AVE.
Healthcare Alternative Systems, Inc.



2nd ATTEMPT AT INTRODUCTION

10/21/2015

Alderman **Gilbert Villegas**
Ward # **36**
City of Chicago
City Hall, Room **200**
121 North LaSalle Street
Chicago, Illinois 60602

Re: An ordinance to use and maintain a portion of the public right-of-way for **one (1) ramp(s)** for **HEALTHCARE ALTERNATIVES**, adjacent to the premises known as **5005 W. Fullerton Ave.**

Dear Alderman **Gilbert Villegas**:

The applicant referenced above has requested the use of the public right-of-way for a **ramp(s)**. An ordinance has been prepared by the Department of Business Affairs and Consumer Protection – Small Business Center - Public Way Use Unit for presentation to the City Council. Because this request was made for properties located in your ward, as approved by you as per the attached, I respectfully request that you introduce the attached ordinance at the next City Council meeting.

If you have any questions regarding this ordinance, please contact Anthony Bertuca at (312) 744-5506.

Department of Business Affairs and Consumer Protection



City of Chicago



O2015-7767

Office of the City Clerk

Document Tracking Sheet

Meeting Date:	10/21/2015
Sponsor(s):	Villegas (36)
Type:	Ordinance
Title:	Grant(s) of privilege in public way for Lucki Communication
Committee(s) Assignment:	Committee on Transportation and Public Way

ORDINANCE
LUCKI COMMUNICATION
Acct. No. 6405 - 2
Permit No. 1119616

Be It Ordained by the City Council of the City of Chicago:

SECTION 1. Permission and authority are hereby given and granted to LUCKI COMMUNICATION, upon the terms and subject to the conditions of this ordinance to maintain and use one (1) sign(s) projecting over the public right-of-way attached to its premises known as 6456 W. Belmont Ave..

Said sign structure(s) measures as follows; along W. Belmont Avenue:
One (1) at eight (8) feet in length, eight (8) feet in height and ten (10) feet above grade level.

The location of said privilege shall be as shown on prints kept on file with the Department of Business Affairs and Consumer Protection and the Office of the City Clerk.

Said privilege shall be constructed in accordance with plans and specifications approved by the Department of Transportation (Division of Project Development) and Zoning Department - Signs.

This grant of privilege in the public way shall be subject to the provisions of Section 10-28-015 and all other required provisions of the Municipal Code of Chicago.

The grantee shall pay to the City of Chicago as compensation for the privilege #1119616 herein granted the sum of three hundred (\$300.00) per annum in advance.

A 25% penalty will be added for payments received after due date.

The permit holder agrees to hold the City of Chicago harmless for any damage, relocation or replacement costs associated with damage, relocation or removal of private property caused by the City performing work in the public way.

Authority herein given and granted for a period of five (5) years from and after Date of Passage.

Alderman  _____

Gilbert Villegas 36th Ward

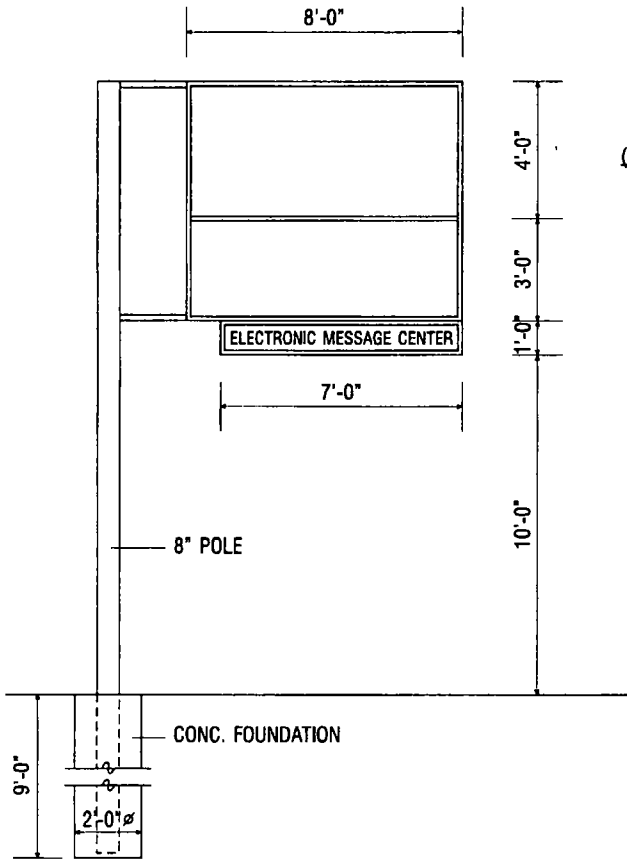

(1) 'D/F ILLUMINATED SIGN



APPROVED _____ DATE _____

M-K SIGNS
 CHICAGO
 4900 N. ELSTON AVE
 CHICAGO, IL 60630
 773-545-4444 / FAX 773-545-9275
 EMAIL: Anthony.Cilia70@yahoo.com
 KC@mksigns.net

LUCKI COMMUNICATIONS
 CHICAGO, IL

Colors represented in this drawing are for presentation purposes only
 They will not match your finished product exactly
 Actual color samples can be obtained from your sales representative
 This design is the original and unpublished work of MK SIGNS and may not be
 reproduced, copied or exhibited in any fashion without the expressed written
 consent of MK SIGNS. The rights to this design may be purchased

DATE	REVISION	SCALE	DATE
		1/4" = 1'-0"	6-15-15
		DESIGNER	SALES
		LM	RC
		FILE	DRAWING NUMBER
		Lucki Communications	2407-2



2nd ATTEMPT AT INTRODUCTION

10/21/2015

Alderman **Gilbert Villegas**
Ward # **36**
City of Chicago
City Hall, Room **200**
121 North LaSalle Street
Chicago, Illinois 60602

Re: An ordinance to use and maintain a portion of the public right-of-way for **one (1) sign(s)** for **LUCKI COMMUNICATION**, adjacent to the premises known as **6456 W. Belmont Ave.**

Dear Alderman **Gilbert Villegas**:

The applicant referenced above has requested the use of the public right-of-way for a **sign(s)**. An ordinance has been prepared by the Department of Business Affairs and Consumer Protection – Small Business Center - Public Way Use Unit for presentation to the City Council. Because this request was made for properties located in your ward, as approved by you as per the attached, I respectfully request that you introduce the attached ordinance at the next City Council meeting.

If you have any questions regarding this ordinance, please contact Anthony Bertuca at (312) 744-5506.

Department of Business Affairs and Consumer Protection



City of Chicago

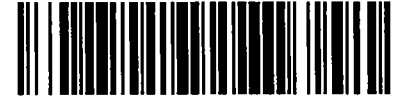

O2015-7768

Office of the City Clerk

Document Tracking Sheet

Meeting Date:	10/21/2015
Sponsor(s):	Villegas (36)
Type:	Ordinance
Title:	Grant(s) of privilege in public way for McGrath City Honda
Committee(s) Assignment:	Committee on Transportation and Public Way

ORDINANCE
MCGRATH CITY HONDA
Acct. No. 311637 - 1
Permit No. 1119667

Be It Ordained by the City Council of the City of Chicago:

SECTION 1. Permission and authority are hereby given and granted to MCGRATH CITY HONDA, upon the terms and subject to the conditions of this ordinance to maintain and use one (1) sign(s) projecting over the public right-of-way attached to its premises known as 6720 W. Grand Ave..

Said sign structure(s) measures as follows; along W. Grand Avenue:
One (1) at eight (8) feet in length, two (2) feet in height and twelve (12) feet above grade level.

The location of said privilege shall be as shown on prints kept on file with the Department of Business Affairs and Consumer Protection and the Office of the City Clerk.

Said privilege shall be constructed in accordance with plans and specifications approved by the Department of Transportation (Division of Project Development) and Zoning Department - Signs.

This grant of privilege in the public way shall be subject to the provisions of Section 10-28-015 and all other required provisions of the Municipal Code of Chicago.

The grantee shall pay to the City of Chicago as compensation for the privilege #1119667 herein granted the sum of one hundred (\$100.00) per annum in advance.

A 25% penalty will be added for payments received after due date.

The permit holder agrees to hold the City of Chicago harmless for any damage, relocation or replacement costs associated with damage, relocation or removal of private property caused by the City performing work in the public way.

Authority herein given and granted for a period of five (5) years from and after Date of Passage.

Alderman _____

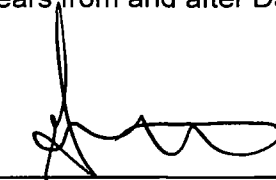

Gilbert Villegas 36th Ward

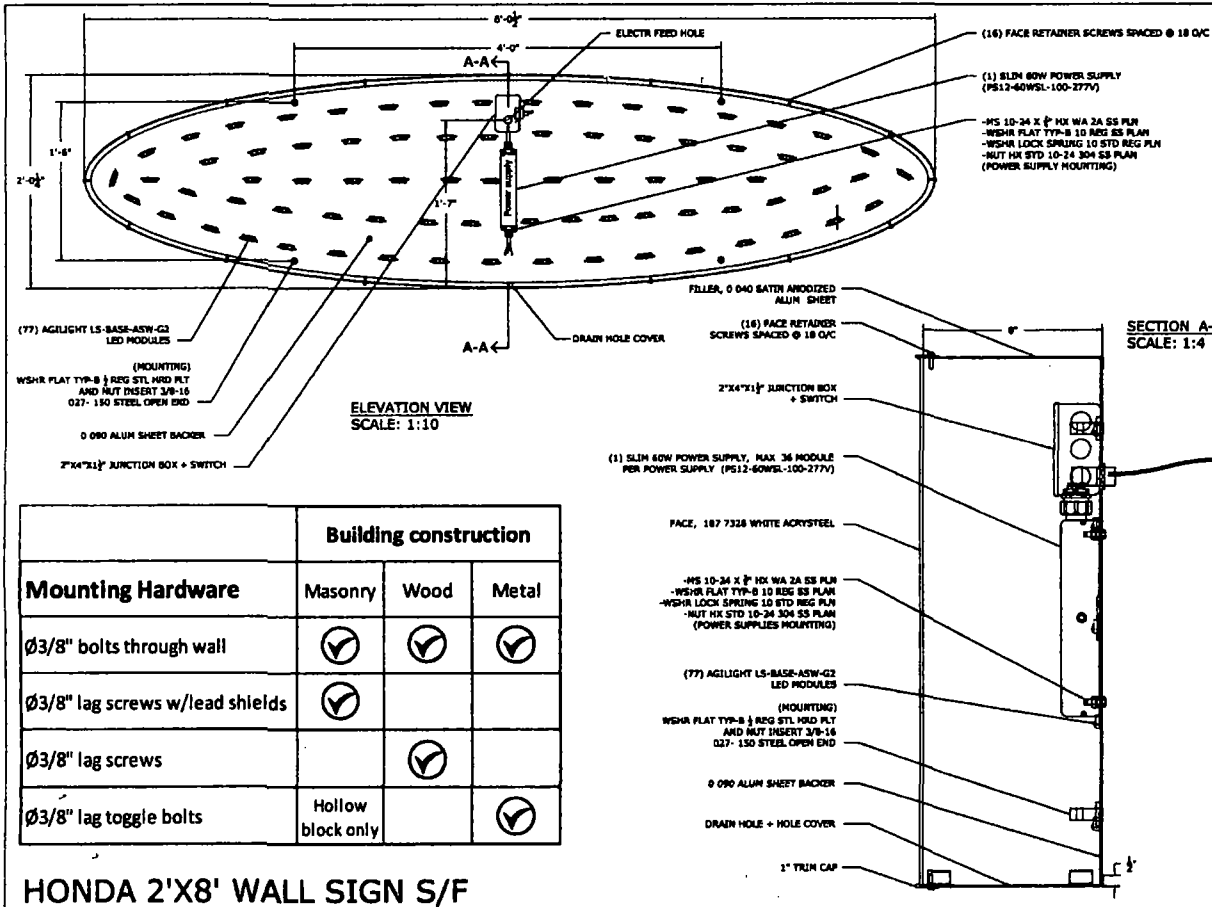

NOTES

This sign is intended to be installed in accordance with the requirements of article 600 of the National code or CSA and other applicable local codes. This includes proper grounding and bonding of the sign. All LED and Electrical components to be UL recognized or classified as listed in the UL sign construction manual (SAB) and in conjunction with UL standards for electric signs (UL48). See Art for graphic details and color specs.

ELECTRICAL

(1) PS12-60WSL-100-277V power supply, 0.63 Amps @ 120 Volts

(77) LS-BASE-ASW-G2 white LED modules

Dealer's Electrician to provide:
(1) 15AMP or 20AMP dedicated circuit behind the wall where oval sign is to be mounted.

Sign installed @ 120 Volts.
Max 15 amp/120 volt circuits
Unless otherwise specified

Pattison Sign Group illuminated signs contain fluorescent, neon and/or HID lamps. These lamps contain Mercury (Hg). Dispose of these lamps according to Local, State, Provincial or Federal Laws.

NOTICE

Patent Sign Group illuminated signs contain fluorescent, neon and/or HID lamps. These lamps contain Mercury (Hg). Dispose of these lamps according to Local, State, Provincial or Federal Laws.

REVISIONS

REV	DESCRIPTION	DATE
01	First revision (24)	Nov 21-14
02	2 hole x 1/2" threaded LED revision (18)	Nov 20-14
03	Location of each hole dimensioned (24)	Nov 22-14
04	Trim detail, mounting short added (24)	Apr 10-14

DATE ORDERED: APR 09-14

QUANTITY: 1/1

MODEL: HONDA 2R x 8R OVAL S/F

FINISH: 2 x 8 SF Oval

Mounting Hardware	Building construction		
	Masonry	Wood	Metal
Ø3/8" bolts through wall	✓	✓	✓
Ø3/8" lag screws w/lead shields	✓		
Ø3/8" lag screws		✓	
Ø3/8" lag toggle bolts	Hollow block only		✓

HONDA 2'X8' WALL SIGN S/F

PATTISON SIGN GROUP INC.

410 N. Cedar Street P.O. Box 191 Danville, VA 24541
Tel (800) 862-7800 Fax (800) 862-7800 Toll Free (800) 218-0233



2nd ATTEMPT AT INTRODUCTION

09/24/2015

Alderman **Gilbert Villegas**
Ward # 36
City of Chicago
City Hall, Room 200
121 North LaSalle Street
Chicago, Illinois 60602

Re: An ordinance to use and maintain a portion of the public right-of-way for **one (1) sign(s)** for **MCGRATH CITY HONDA**, adjacent to the premises known as **6720 W. Grand Ave.**.

Dear Alderman **Gilbert Villegas**:

The applicant referenced above has requested the use of the public right-of-way for a **sign(s)**. An ordinance has been prepared by the Department of Business Affairs and Consumer Protection – Small Business Center - Public Way Use Unit for presentation to the City Council. Because this request was made for properties located in your ward, as approved by you as per the attached, I respectfully request that you introduce the attached ordinance at the next City Council meeting.

If you have any questions regarding this ordinance, please contact Anthony Bertuca at (312) 744-5506.

Department of Business Affairs and Consumer Protection



City of Chicago



O2015-7770

Office of the City Clerk

Document Tracking Sheet

Meeting Date:	10/21/2015
Sponsor(s):	Villegas (36)
Type:	Ordinance
Title:	Grant(s) of privilege in public way for Menasha Packaging Co. LLC
Committee(s) Assignment:	Committee on Transportation and Public Way

ORDINANCE
MENASHA PACKAGING COMPANY, LLC
Acct. No. 391013 - 3
Permit No. 1120162

Be It Ordained by the City Council of the City of Chicago:

SECTION 1. Permission and authority are hereby given and granted to MENASHA PACKAGING COMPANY, LLC, upon the terms and subject to the conditions of this ordinance to maintain and use one (1) sign(s) projecting over the public right-of-way attached to its premises known as 4545 W. Palmer St..

Said sign structure(s) measures as follows; along W. Palmer Street:
One (1) at four (4) feet in length, three (3) feet in height and twelve (12) feet above grade level.

The location of said privilege shall be as shown on prints kept on file with the Department of Business Affairs and Consumer Protection and the Office of the City Clerk.

Said privilege shall be constructed in accordance with plans and specifications approved by the Department of Transportation (Division of Project Development) and Zoning Department - Signs.

This grant of privilege in the public way shall be subject to the provisions of Section 10-28-015 and all other required provisions of the Municipal Code of Chicago.

The grantee shall pay to the City of Chicago as compensation for the privilege #1120162 herein granted the sum of one hundred (\$100.00) per annum in advance.

A 25% penalty will be added for payments received after due date.

The permit holder agrees to hold the City of Chicago harmless for any damage, relocation or replacement costs associated with damage, relocation or removal of private property caused by the City performing work in the public way.

Authority herein given and granted for a period of five (5) years from and after 01/09/2013.

Alderman _____



Gilbert Villegas 36th Ward

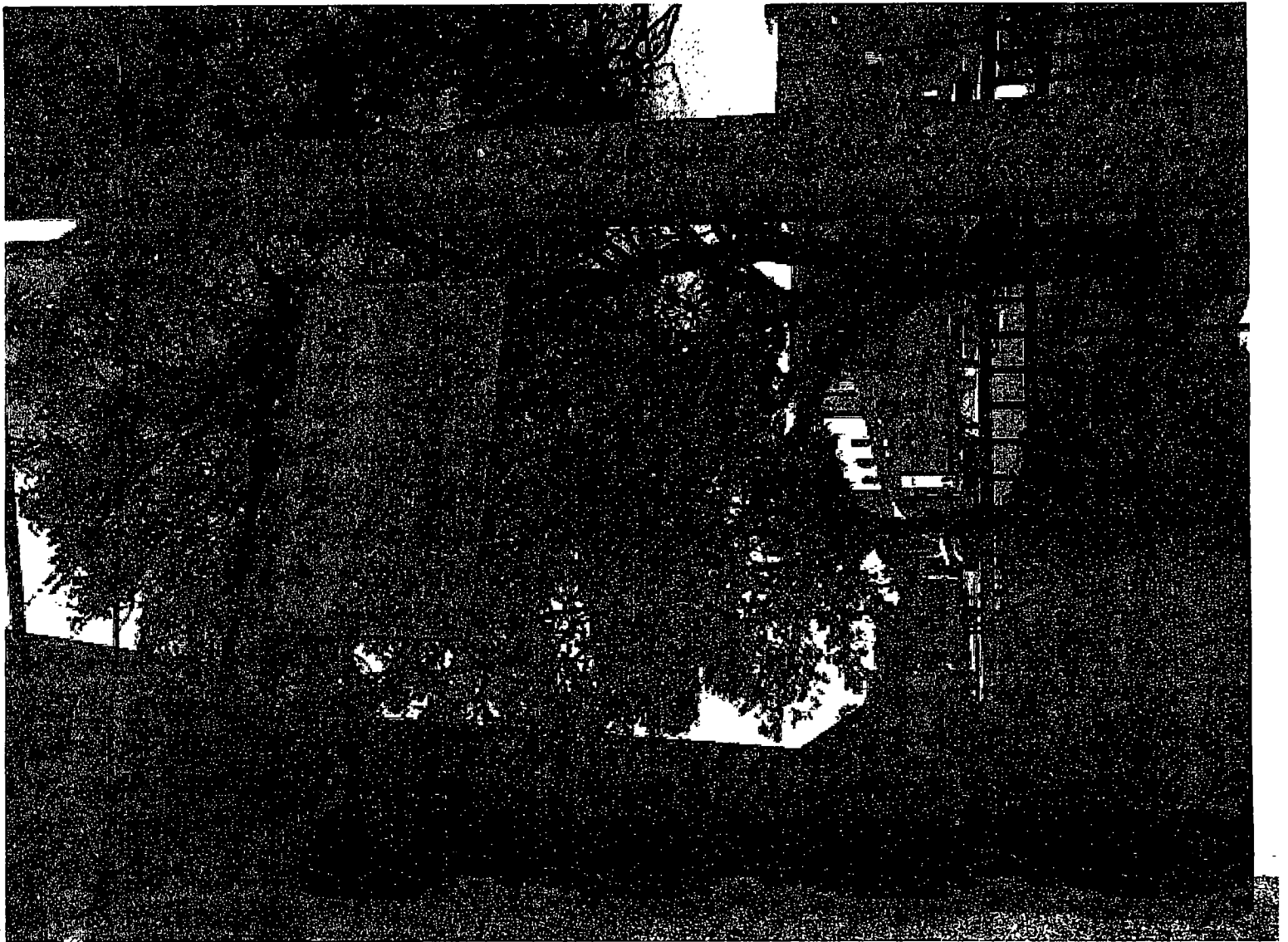



2nd ATTEMPT AT INTRODUCTION

10/21/2015

Alderman **Gilbert Villegas**
Ward # **36**
City of Chicago
City Hall, Room **200**
121 North LaSalle Street
Chicago, Illinois 60602

Re: An ordinance to use and maintain a portion of the public right-of-way for **one (1) sign(s)** for
MENASHA PACKAGING COMPANY, LLC, adjacent to the premises known as **4545 W.**
Palmer St.

Dear Alderman **Gilbert Villegas**:

The applicant referenced above has requested the use of the public right-of-way for a **sign(s)**. An ordinance has been prepared by the Department of Business Affairs and Consumer Protection – Small Business Center - Public Way Use Unit for presentation to the City Council. Because this request was made for properties located in your ward, as approved by you as per the attached, I respectfully request that you introduce the attached ordinance at the next City Council meeting.

If you have any questions regarding this ordinance, please contact Anthony Bertuca at (312) 744-5506.

Department of Business Affairs and Consumer Protection



City of Chicago



O2015-7772

Office of the City Clerk

Document Tracking Sheet

Meeting Date:	10/21/2015
Sponsor(s):	Villegas (36)
Type:	Ordinance
Title:	Grant(s) of privilege in public way for Walgreens No. 5121 - light fixtures
Committee(s) Assignment:	Committee on Transportation and Public Way

ORDINANCE
WALGREENS #5121
Acct. No. 7551 - 64
Permit No. 1119731

Be It Ordained by the City Council of the City of Chicago:

SECTION 1. Permission and authority are hereby given and granted to WALGREENS #5121, upon the terms and subject to the conditions of this ordinance to maintain and use, as now constructed, seven (7) Light Fixture(s) projecting over the public right-of-way adjacent to its premises known as 5935 W. Addison St..

Said Light Fixture(s) at W. ADDISON measure(s):
Seven (7) at one (1) foot in length, point six seven (.67) feet in width and ten point five (10.5) feet above grade level.

The location of said privilege shall be as shown on prints kept on file with the Department of Business Affairs and Consumer Protection and the Office of the City Clerk.

Said privilege shall be constructed in accordance with plans and specifications approved by the Department of Transportation (Division of Project Development).

This grant of privilege in the public way shall be subject to the provisions of Section 10-28-015 and all other required provisions of the Municipal Code of Chicago.

The grantee shall pay to the City of Chicago as compensation for the privilege #1119731 herein granted the sum of one hundred five (\$105.00) per annum in advance.

A 25% penalty will be added for payments received after due date.

The permit holder agrees to hold the City of Chicago harmless for any damage, relocation or replacement costs associated with damage, relocation or removal of private property caused by the City performing work in the public way.

Authority herein given and granted for a period of five (5) years from and after 06/03/2014.

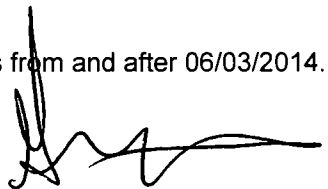
Alderman 

Gilbert Villegas 36th Ward





2nd ATTEMPT AT INTRODUCTION

10/21/2015

Alderman **Gilbert Villegas**
Ward # **36**
City of Chicago
City Hall, Room **200**
121 North LaSalle Street
Chicago, Illinois 60602

Re: An ordinance to use and maintain a portion of the public right-of-way for **seven (7) light fixture(s)** for **WALGREENS #5121**, adjacent to the premises known as **5935 W. Addison St.**

Dear Alderman **Gilbert Villegas**:

The applicant referenced above has requested the use of the public right-of-way for a **light fixture(s)**. An ordinance has been prepared by the Department of Business Affairs and Consumer Protection – Small Business Center - Public Way Use Unit for presentation to the City Council. Because this request was made for properties located in your ward, as approved by you as per the attached, I respectfully request that you introduce the attached ordinance at the next City Council meeting.

If you have any questions regarding this ordinance, please contact Anthony Bertuca at (312) 744-5506.

Department of Business Affairs and Consumer Protection



City of Chicago



O2015-7773

Office of the City Clerk

Document Tracking Sheet

Meeting Date:	10/21/2015
Sponsor(s):	Villegas (36)
Type:	Ordinance
Title:	Grant(s) of privilege in public way for Walgreens No. 5121 - signs
Committee(s) Assignment:	Committee on Transportation and Public Way

ORDINANCE
WALGREENS #5121
Acct. No. 7551 - 64
Permit No. 1119732

Be It Ordained by the City Council of the City of Chicago:

SECTION 1. Permission and authority are hereby given and granted to WALGREENS #5121, upon the terms and subject to the conditions of this ordinance to maintain and use three (3) sign(s) projecting over the public right-of-way attached to its premises known as 5935 W. Addison St..

Said sign structure(s) measures as follows; along W. ADDISON:

One (1) at thirty-seven point eight three (37.83) feet in length, four (4) feet in height and fifteen (15) feet above grade level.

Said sign structure(s) measures as follows; along W. ADDISON:

One (1) at fourteen (14) feet in length, one point five (1.5) feet in height and thirteen (13) feet above grade level.

Said sign structure(s) measures as follows; along W. ADDISON:

One (1) at twelve point eight three (12.83) feet in length, one point five (1.5) feet in height and thirteen (13) feet above grade level.

The location of said privilege shall be as shown on prints kept on file with the Department of Business Affairs and Consumer Protection and the Office of the City Clerk.

Said privilege shall be constructed in accordance with plans and specifications approved by the Department of Transportation (Division of Project Development) and Zoning Department - Signs.

This grant of privilege in the public way shall be subject to the provisions of Section 10-28-015 and all other required provisions of the Municipal Code of Chicago.

The grantee shall pay to the City of Chicago as compensation for the privilege #1119732 herein granted the sum of four hundred seventy-five (\$475.00) per annum in advance.

A 25% penalty will be added for payments received after due date.

The permit holder agrees to hold the City of Chicago harmless for any damage, relocation or replacement costs associated with damage, relocation or removal of private property caused by the City performing work in the public way.

Authority herein given and granted for a period of five (5) years from and after 04/22/2014.

Alderman

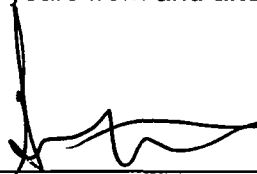

Gilbert Villegas 36th Ward



5121



2nd ATTEMPT AT INTRODUCTION

10/21/2015

Alderman **Gilbert Villegas**
Ward # 36
City of Chicago
City Hall, Room 200
121 North LaSalle Street
Chicago, Illinois 60602

Re: An ordinance to use and maintain a portion of the public right-of-way for **three (3) sign(s)** for **WALGREENS #5121**, adjacent to the premises known as **5935 W. Addison St.**

Dear Alderman **Gilbert Villegas**:

The applicant referenced above has requested the use of the public right-of-way for a **sign(s)**. An ordinance has been prepared by the Department of Business Affairs and Consumer Protection – Small Business Center - Public Way Use Unit for presentation to the City Council. Because this request was made for properties located in your ward, as approved by you as per the attached, I respectfully request that you introduce the attached ordinance at the next City Council meeting.

If you have any questions regarding this ordinance, please contact Anthony Bertuca at (312) 744-5506.

Department of Business Affairs and Consumer Protection



City of Chicago



O2015-7759

Office of the City Clerk

Document Tracking Sheet

Meeting Date:	10/21/2015
Sponsor(s):	Reilly (42)
Type:	Ordinance
Title:	Grant(s) of privilege in public way for AMC Dine-In Theatres Block 37 - banner
Committee(s) Assignment:	Committee on Transportation and Public Way

ORDINANCE
AMC DINE-IN THEATRES BLOCK 37
Acct. No. 313337 - 6
Permit No. 1119965

Be It Ordained by the City Council of the City of Chicago:

SECTION 1. Permission and authority are hereby given and granted to AMC DINE-IN THEATRES BLOCK 37, upon the terms and subject to the conditions of this ordinance to construct, install, maintain and use one (1) Banner(s) projecting over the public right-of-way adjacent to its premises known as 108 N. State St..

Said Banner(s) at N DEARBORN ST measure(s):

One (1) at three point four two (3.42) feet in length, and thirty-seven point five eight (37.58) feet in width for a total of one hundred twenty-eight point five two (128.52) square feet.

The location of said privilege shall be as shown on prints kept on file with the Department of Business Affairs and Consumer Protection and the Office of the City Clerk.

Said privilege shall be constructed in accordance with plans and specifications approved by the Zoning Department - Signs.

This grant of privilege in the public way shall be subject to the provisions of Section 10-28-015 and all other required provisions of the Municipal Code of Chicago.

The grantee shall pay to the City of Chicago as compensation for the privilege #1119965 herein granted the sum of seventy-five (\$75.00) per annum in advance.

A 25% penalty will be added for payments received after due date.

The permit holder agrees to hold the City of Chicago harmless for any damage, relocation or replacement costs associated with damage, relocation or removal of private property caused by the City performing work in the public way.

Authority herein given and granted for a period of five (5) years from and after Date of Passage.

Alderman 

Brendan Reilly 42nd Ward

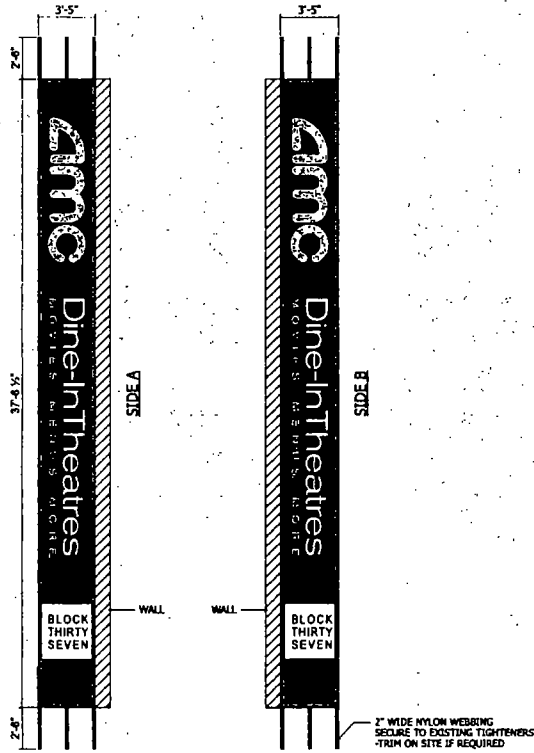

WF205-2 D/F HANGING SUNBRELLA BANNER SCALE 3/16" = 1'-0"
 ONE (1) REQUIRED - MANUFACTURE AND INSTALL SQ FT 128.27
 REMOVE EXISTING D/F BANNER AND LEAVE WITH LANDLORD
 MANUFACTURE AND INSTALL ONE (1) NEW D/F BANNER TO MATCH EXISTING SIZE
 SUNBRELLA BANNER TO BE HEMMED WITH BLACK 2" WEBBING AS NEEDED
 ALL COPY TO BE SILK SCREENED

41 x 150 = 128



PHOTO - EXISTING

NTS



PHOTO - AFTER

NTS



0610726AR3	
Rev	4 of 5
AMC BLOCK 37	
108 N STATE ST CHICAGO IL 60602	
Proj No	Stan Museum
Designer	Justin Bernhardt
Drawn	J GARCIA
Date	3/4/15
Client	
Contract	
Location	
Contract No.	

CHANDLER SIGNS 1000 N. LAKE ST. SUITE 100 CHICAGO, IL 60610 (773) 327-1111 www.chandler-signs.com

Chandler Signs 1000 N. LAKE ST. SUITE 100 CHICAGO, IL 60610 (773) 327-1111 www.chandler-signs.com

FINAL ELECTRICAL CONNECTION BY CUSTOMER



City of Chicago



O2015-7761

Office of the City Clerk

Document Tracking Sheet

Meeting Date:	10/21/2015
Sponsor(s):	Reilly (42)
Type:	Ordinance
Title:	Grant(s) of privilege in public way for AMC Dine-In Theatres Block 37 - sign
Committee(s) Assignment:	Committee on Transportation and Public Way

ORDINANCE
AMC DINE-IN THEATRES BLOCK 37
Acct. No. 313337 - 6
Permit No. 1119966

Be It Ordained by the City Council of the City of Chicago:

SECTION 1. Permission and authority are hereby given and granted to AMC DINE-IN THEATRES BLOCK 37, upon the terms and subject to the conditions of this ordinance to maintain and use one (1) sign(s) projecting over the public right-of-way attached to its premises known as 108 N. State St..

Said sign structure(s) measures as follows; along N STATE ST:

One (1) at five (5) feet in length, forty-five (45) feet in height and eighteen (18) feet above grade level.

The location of said privilege shall be as shown on prints kept on file with the Department of Business Affairs and Consumer Protection and the Office of the City Clerk.

Said privilege shall be constructed in accordance with plans and specifications approved by the Department of Transportation (Division of Project Development) and Zoning Department - Signs.

This grant of privilege in the public way shall be subject to the provisions of Section 10-28-015 and all other required provisions of the Municipal Code of Chicago.

The grantee shall pay to the City of Chicago as compensation for the privilege #1119966 herein granted the sum of three hundred (\$300.00) per annum in advance.

A 25% penalty will be added for payments received after due date.

The permit holder agrees to hold the City of Chicago harmless for any damage, relocation or replacement costs associated with damage, relocation or removal of private property caused by the City performing work in the public way.

Authority herein given and granted for a period of five (5) years from and after Date of Passage.

Alderman

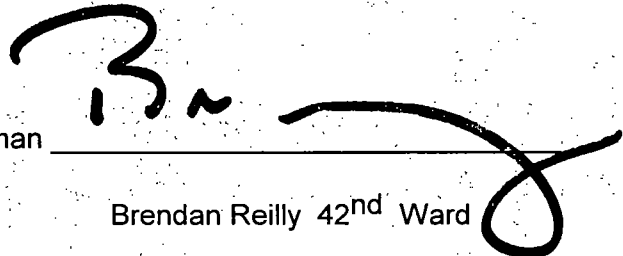

Brendan Reilly 42nd Ward

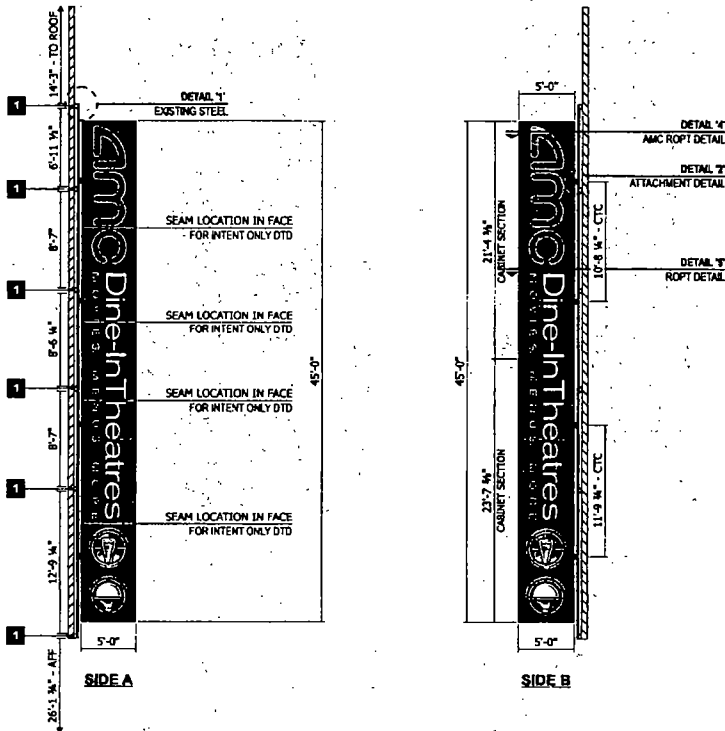

WF205-1 D/F ROFT ALUM. BLADE SIGN SCALE 1/8" = 1'-0"
 ONE (1) REQUIRED - MANUFACTURE AND INSTALL SQ FT 225

ALUMINUM CABINET FACES, FILLER & SUPPORTS TO BE PAINTED MP#H923 FLAT BLACK
 COPY & LOGOS TO BE ROUTED OUT PUSH THRU ACRYLIC WITH PRINTED 1ST SURFACE VINYL
 & 2ND SURFACE WHITE DIFFUSER

SEE DETAILS ON NEXT PAGE

ENGINEERING REQUIRED



EXISTING 5" STEEL SQ TUBE SUPPORT

NOTE DIMENSIONS SHOWN PER SURVEY



0810726AR3	
Rev	2 of 5
AMC BLOCK #7	
108 N STATE ST CHICAGO IL 60602	
Aut No	0881 Mactern
Customer	AMC Block #7
Designer	J. GARCIA
Date	3/4/15
Client	
Scale	
Notes	
Comments	

Chandler Signs

1000 N. State St. Chicago, IL 60610
 Phone: (773) 327-1111
 Fax: (773) 327-1112
 Website: www.chandler-signs.com

FINAL ELECTRICAL CONNECTION BY CUSTOMER



City of Chicago



O2015-7762

Office of the City Clerk

Document Tracking Sheet

Meeting Date:	10/21/2015
Sponsor(s):	Reilly (42)
Type:	Ordinance
Title:	Grant(s) of privilege in public way for Beacon Tavern
Committee(s) Assignment:	Committee on Transportation and Public Way

ORDINANCE
BEACON TAVERN
Acct. No. 401471 - 1
Permit No. 1120265

Be It Ordained by the City Council of the City of Chicago:

SECTION 1. Permission and authority are hereby given and granted to BEACON TAVERN, upon the terms and subject to the conditions of this ordinance to construct, install, maintain and use three (3) Window & Frame(s) which will swing out over the public right-of-way adjacent to its premises known as 405 N. Wabash Ave..

Said Window & Frame(s) at N. WABASH AVE measure(s):

Two (2) at thirteen point zero four (13.04) feet in length, and two (2) feet in width for a total of fifty-two point one six (52.16) square feet. Said window & frame (s) shall be two (2) feet above grade level.

One (1) at ten (10) feet in length, and two (2) feet in width for a total of twenty (20) square feet. Said window & frame shall be two (2) feet above grade level.

The location of said privilege shall be as shown on prints kept on file with the Department of Business Affairs and Consumer Protection and the Office of the City Clerk.

Said privilege shall be constructed in accordance with plans and specifications approved by the Department of Planning and Development and Department of Transportation (Division of Project Development).

This grant of privilege in the public way shall be subject to the provisions of Section 10-28-015 and all other required provisions of the Municipal Code of Chicago.

The grantee shall pay to the City of Chicago as compensation for the privilege #1120265 herein granted the sum of two hundred twenty-five (\$225.00) per annum in advance.

A 25% penalty will be added for payments received after due date.

The permit holder agrees to hold the City of Chicago harmless for any damage, relocation or replacement costs associated with damage, relocation or removal of private property caused by the City performing work in the public way.

Authority herein given and granted for a period of five (5) years from and after Date of Passage.

Alderman _____

Brendan Reilly 42nd Ward



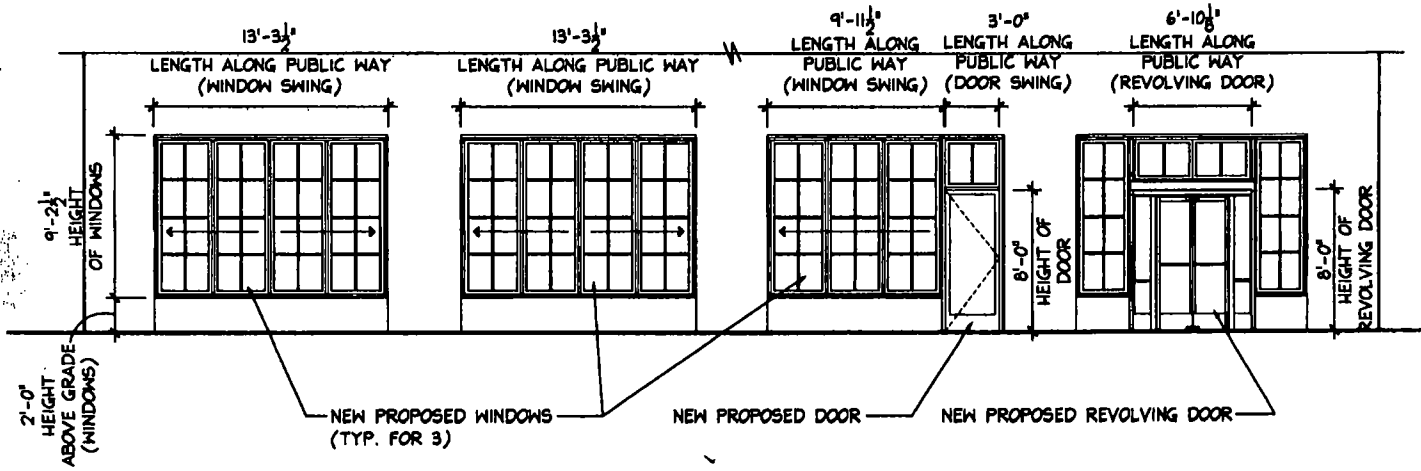

SOUTH PROPOSED PUBLIC WAY ELEVATION

1/8" = 1'-0"



JSa

Jonathan SPLITT architects Ltd.

4001 north reynolds avenue
suite 601
chicago illinois 60613
773 888 1017 fax 773 883 3061

proj.# 1522 MICHIGAN AVE ENTERPRISES LLC
 proj. BEACON TAVERN
 INT. BUILDOUT - NEW RESTAURANT
 405 N HABASH AVE
 CHICAGO, IL

description 9/21/15, ISSUED FOR REVIEW





City of Chicago



O2015-7764

Office of the City Clerk

Document Tracking Sheet

Meeting Date:	10/21/2015
Sponsor(s):	Reilly (42)
Type:	Ordinance
Title:	Grant(s) of privilege in public way for Northwestern University
Committee(s) Assignment:	Committee on Transportation and Public Way

ORDINANCE
NORTHWESTERN UNIVERSITY
Acct. No. 69296 - 1
Permit No. 1120359

Be It Ordained by the City Council of the City of Chicago:

SECTION 1. Permission and authority are hereby given and granted to NORTHWESTERN UNIVERSITY, upon the terms and subject to the conditions of this ordinance to construct, install, maintain and use three (3) Conduit(s) under the public right-of-way adjacent to its premises known as 710 N. Lake Shore Dr..

Said Conduit(s) at E. Erie Street measure(s):

One (1) at seventy-four (74) feet in length, and point three three (.33) feet in width for a total of twenty-four point four two (24.42) square feet.

One (1) at seventy-five (75) feet in length, and point three three (.33) feet in width for a total of twenty-four point seven five (24.75) square feet.

Said Conduit(s) at E. Houron Street measure(s):

One (1) at seventy-eight (78) feet in length, and point three three (.33) feet in width for a total of twenty-five point seven four (25.74) square feet.

The location of said privilege shall be as shown on prints kept on file with the Department of Business Affairs and Consumer Protection and the Office of the City Clerk.

Said privilege shall be constructed in accordance with plans and specifications approved by the Department of Transportation (Division of Project Development) and Department of Transportation (Office of Underground Coordination).

This grant of privilege in the public way shall be subject to the provisions of Section 10-28-015 and all other required provisions of the Municipal Code of Chicago.

The grantee shall pay to the City of Chicago as compensation for the privilege #1120359 herein granted the sum of one thousand three hundred sixty-two (\$1,362.00) per annum in advance.

A 25% penalty will be added for payments received after due date.

The permit holder agrees to hold the City of Chicago harmless for any damage, relocation or replacement costs associated with damage, relocation or removal of private property caused by the City performing work in the public way.

Authority herein given and granted for a period of five (5) years from and after Date of Passage.

Alderman _____

Brendan Reilly 42nd Ward

Handwritten scribble or signature.



OUTSIDE PLANT FIBER OPTIC BUILD

Northwestern University
710 N LAKE SHORE DRIVE
CHICAGO, IL 60611

DRAWING INDEX:	
SHEET	DRAWING TITLE
1	COVER
2	LEGEND
3	NOTES AND ABBREVIATIONS
4-5	TYPICALS
6	PROJECT SUMMARY
7-8	TRAFFIC PLANS
9	RESTORATION PLANS
10-11	PLANS
12-14	PROFILES

REV	DATE	DESCRIPTION	BY
	08/18/15	CONSTRUCTION DRAWING	JR

THIS DOCUMENT CONTAINS CONFIDENTIAL INFORMATION AND IS THE PROPERTY OF THE OWNER. RELEASE OR DISTRIBUTION OF THIS DOCUMENT IN ANY FORM TO ANYONE WITHOUT WRITTEN PERMISSION OF THE OWNER IS STRICTLY PROHIBITED.



CALL CHICAGO DIGGERS HOTLINE
1-312-364-7000
REQUIRES 911
NOTICE BEFORE YOU DIG/AWAY

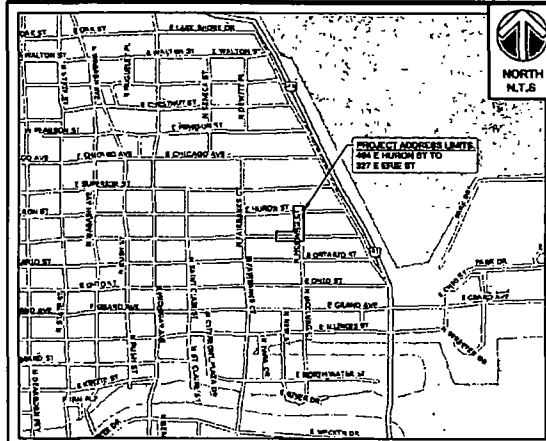

PROJECT LOCATION:
LOCATION: SEC 10, T39N-R14E
CHICAGO, COOK COUNTY, ILLINOIS

PROJECT (1537-001) DESCRIPTION:
INSTALLATION OF (1)-1" HOPE 808-11 CONDUIT & (1)-1" PVC SCHEDULE 40 CONDUIT W/ (2)-2" & (1)-1" OF 808-11 HOPE PRODUCTS @ 4" MINIMUM DEPTH BY UNIDIRECTIONAL BORE AND OPEN CUT/TRENCH TO THE ABOVE MENTIONED ADDRESS

CONSTRUCTION DRAWING

CONTACT LIST:

OWNER:
DOUG DEKORSON
FIELD OPERATIONS MANAGER
NORTHWESTERN UNIVERSITY
INFORMATION TECHNOLOGY
3001 BRIDGEMAN RD, LEVEONE HALL
6-110 EVANSTON, IL 60208
PHONE: (847) 487-1008
CELL: (847) 388-0809

CONTRACTOR:

T.B.D.

DESIGN FIRM:
LAURANCE P. LEVINS
CEO
COMDESCO GROUP, INC.
184 BRIMMAN BLVD, SUITE 575
PAPERVILLE, IL 60563
PHONE: (708) 395-3000
FAX: (708) 394-4341



City of Chicago



O2015-7766

Office of the City Clerk

Document Tracking Sheet

Meeting Date:	10/21/2015
Sponsor(s):	Reilly (42)
Type:	Ordinance
Title:	Grant(s) of privilege in public way for Northwestern Memorial Hospital
Committee(s) Assignment:	Committee on Transportation and Public Way

ORDINANCE
NORTHWESTERN MEMORIAL HOSPITAL
Acct. No. 69273 - 12
Permit No. 1120343

Be It Ordained by the City Council of the City of Chicago:

SECTION 1. Permission and authority are hereby given and granted to NORTHWESTERN MEMORIAL HOSPITAL, upon the terms and subject to the conditions of this ordinance to maintain and use, as now constructed, one (1) Manhole(s) under the public right-of-way adjacent to its premises known as 201 E. Huron St..

Said Manhole(s) at E. Erie measure(s):

One (1) at two (2) feet in length, and two (2) feet in width for a total of four (4) square feet.

The location of said privilege shall be as shown on prints kept on file with the Department of Business Affairs and Consumer Protection and the Office of the City Clerk.

Said privilege shall be constructed in accordance with plans and specifications approved by the Department of Transportation (Office of Underground Coordination) and Department of Water Management.

This grant of privilege in the public way shall be subject to the provisions of Section 10-28-015 and all other required provisions of the Municipal Code of Chicago.

The grantee shall pay to the City of Chicago as compensation for the privilege #1120343 herein granted the sum of four hundred (\$400.00) per annum in advance.

A 25% penalty will be added for payments received after due date.

The permit holder agrees to hold the City of Chicago harmless for any damage, relocation or replacement costs associated with damage, relocation or removal of private property caused by the City performing work in the public way.

Authority herein given and granted for a period of five (5) years from and after 10/06/2015.

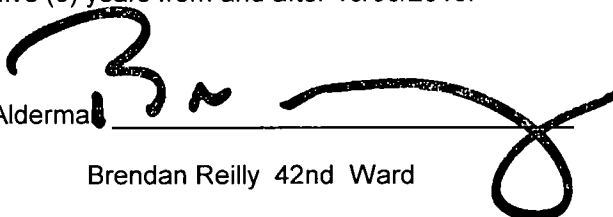
Alderman 
Brendan Reilly 42nd Ward

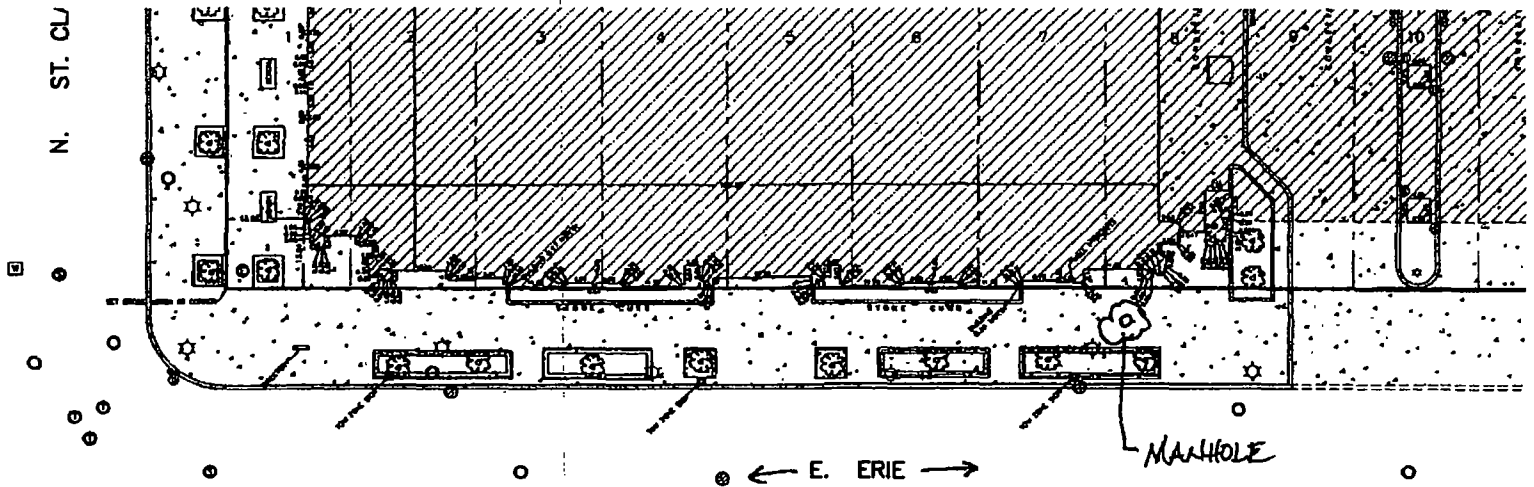

ORDERED BY: NORTHWESTERN MEMORIAL HOSPITAL	CHECKED: #68	DRAWN: BS
ADDRESS: 251 E. MURKIN, CHICAGO, IL		
 CHICAGO GUARANTEE SURVEY COMPANY		
A DIVISION OF PLCS, CORPORATION LICENSE NO. 031-001322 PROFESSIONAL LAND SURVEYORS 4505 NORTH ELSTON AVENUE, CHICAGO, IL 60630 TELEPHONE: (312) 986-9445 FAX: (312) 986-9679 EMAIL: DFD@PLCS-SURVEY.COM		
ORDER NO.	DATE	PAGE NO.
2010-13965-001	MAY 25, 2010	1 of 1
SCALE: 1 INCH = 15 FEET		

Distances are to
BEFORE building
done.

For easements,
to your abstract

NO dimensions

Unless otherwise
Datum if used

COPYRIGHT CHIC

C:\CAD\2010\2010-13965\dwg\2010-13965-001.dwg

PARTIAL SITE PLAN
MANHOLE, 69273-12
PWH 1093050





City of Chicago



O2015-7769

Office of the City Clerk

Document Tracking Sheet

Meeting Date:	10/21/2015
Sponsor(s):	Reilly (42)
Type:	Ordinance
Title:	Grant(s) of privilege in public way for RMW Streeterville LLC
Committee(s) Assignment:	Committee on Transportation and Public Way

ORDINANCE
RMW STREETERVILLE LLC
Acct. No. 399254 - 2
Permit No. 1120381

Be It Ordained by the City Council of the City of Chicago:

SECTION 1. Permission and authority are hereby given and granted to RMW STREETERVILLE LLC, upon the terms and subject to the conditions of this ordinance to construct, install, maintain and use two (2) Conduit(s) under the public right-of-way adjacent to its premises known as 451 E. Grand Ave..

Said Conduit(s) at E Grand Ave measure(s):

One (1) at one hundred fifty (150) feet in length, and one point two five (1.25) foot in width for a total of one hundred eighty-seven point five (187.5) square feet.

Said Conduit(s) at N Peshtigo Ct measure(s):

One (1) at one hundred seventy-three point zero eight (173.08) feet in length, and twelve point five (12.5) feet in width for a total of two thousand one hundred sixty-three point five (2163.5) square feet.

The location of said privilege shall be as shown on prints kept on file with the Department of Business Affairs and Consumer Protection and the Office of the City Clerk.

Said privilege shall be constructed in accordance with plans and specifications approved by the Department of Transportation (Division of Project Development) and Department of Transportation (Office of Underground Coordination).

This grant of privilege in the public way shall be subject to the provisions of Section 10-28-015 and all other required provisions of the Municipal Code of Chicago.

The grantee shall pay to the City of Chicago as compensation for the privilege #1120381 herein granted the sum of one thousand nine hundred thirty-eight dollars and forty-eight cents (\$1,938.48) per annum in advance.

A 25% penalty will be added for payments received after due date.

The permit holder agrees to hold the City of Chicago harmless for any damage, relocation or replacement costs associated with damage, relocation or removal of private property caused by the City performing work in the public way.

Authority herein given and granted for a period of five (5) years from and after Date of Passage.

Alderman _____

Brendan Reilly 42nd Ward

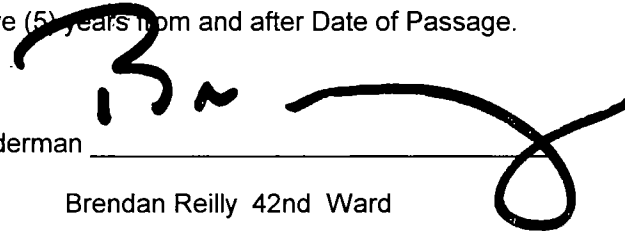
A handwritten signature in black ink, appearing to read 'B. Reilly', is written over a horizontal line. The signature is stylized and extends to the right of the line.

Handwritten scribbles and marks, possibly a signature or initials, located in the lower-left quadrant of the page.

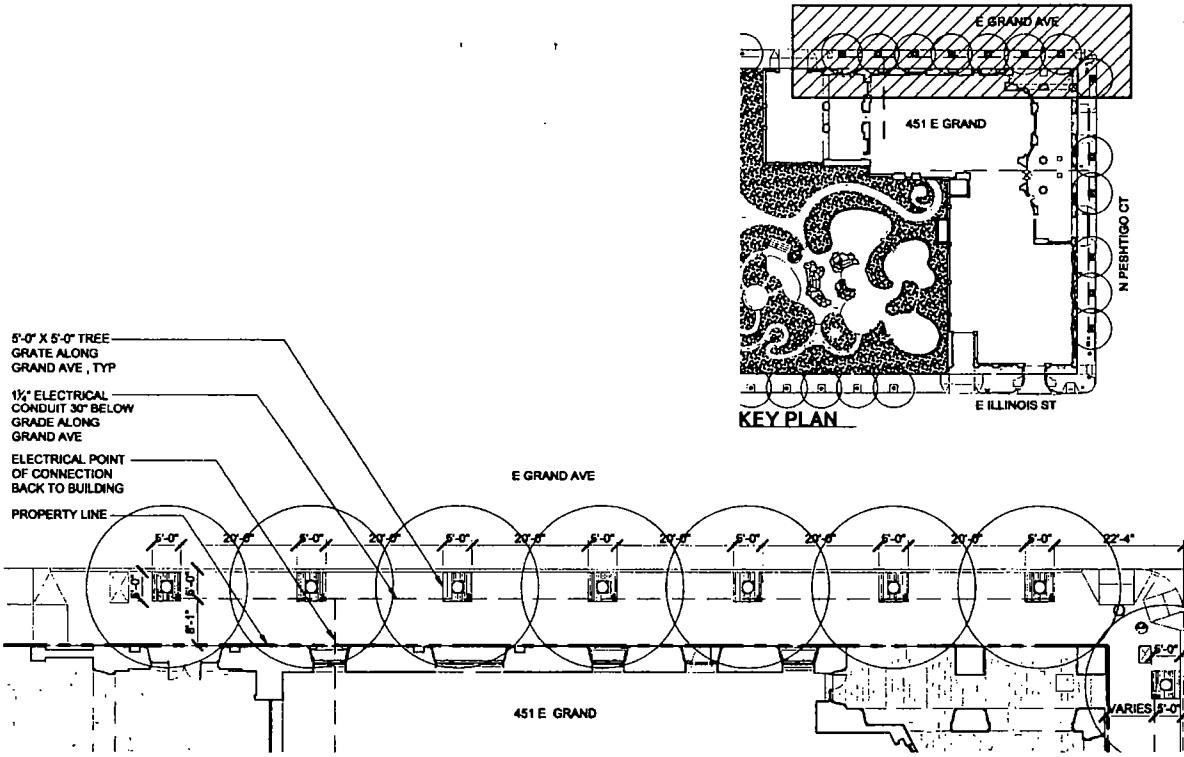

GOP-SK-001: TREE GRATES - E GRAND AVE.

SCALE 1/4" = 1'-0"





City of Chicago



O2015-7771

Office of the City Clerk

Document Tracking Sheet

Meeting Date:	10/21/2015
Sponsor(s):	Tunney (44)
Type:	Ordinance
Title:	Grant(s) of privilege in public way for Blackwood BBQ
Committee(s) Assignment:	Committee on Transportation and Public Way

ORDINANCE
BLACKWOOD BBQ
Acct. No. 381102 - 6
Permit No. 1120399

Be It Ordained by the City Council of the City of Chicago:

SECTION 1. Permission and authority are hereby given and granted to BLACKWOOD BBQ, upon the terms and subject to the conditions of this ordinance to construct, install, maintain and use ten (10) Light Fixture(s) projecting over the public right-of-way adjacent to its premises known as 962 W. Belmont Ave..

Said Light Fixture(s) at Sheffield measure(s):

Five (5) at one point five (1.5) foot in length, one point five (1.5) foot in width and seven point eight four (7.84) feet above grade level.

Said Light Fixture(s) at Corner of Belmont and Sheffield measure(s):

Two (2) at one point six seven (1.67) foot in length, one point five nine (1.59) foot in width and fifteen (15) feet above grade level.

Said Light Fixture(s) at Belmont measure(s):

Three (3) at two point six seven (2.67) feet in length, one point five nine (1.59) foot in width and fifteen (15) feet above grade level.

The location of said privilege shall be as shown on prints kept on file with the Department of Business Affairs and Consumer Protection and the Office of the City Clerk.

Said privilege shall be constructed in accordance with plans and specifications approved by the Department of Transportation (Division of Project Development).

This grant of privilege in the public way shall be subject to the provisions of Section 10-28-015 and all other required provisions of the Municipal Code of Chicago.

The grantee shall pay to the City of Chicago as compensation for the privilege #1120399 herein granted the sum of one hundred twenty (\$120.00) per annum in advance.

A 25% penalty will be added for payments received after due date.

The permit holder agrees to hold the City of Chicago harmless for any damage, relocation or replacement costs associated with damage, relocation or removal of private property caused by the City performing work in the public way.

Authority herein given and granted for a period of five (5) years from and after Date of Passage.

Alderman _____



Thomas Tunney 44th Ward

Blackwood BBQ - 962 W Belmont Ave

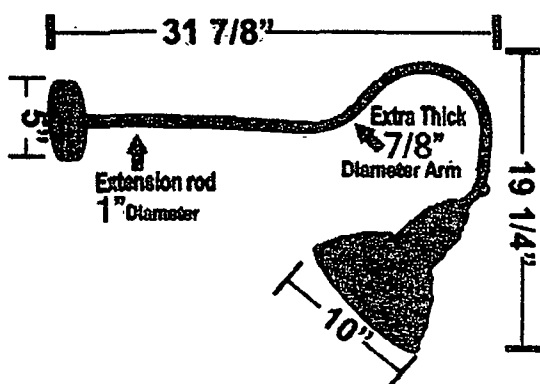
Lighting Application

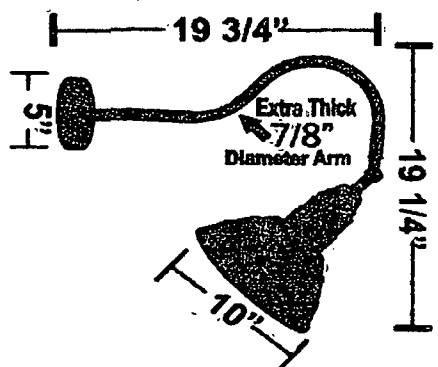

Above Awnings
Three Above Belmont Side Awning
and One Above One Sheffield Awning



Two with Pig Sign



10/21/2015

Alderman **Thomas Tunney**
Ward # 44
City of Chicago
City Hall, Room 300
121 North LaSalle Street
Chicago, Illinois 60602

Re: An ordinance to use and maintain a portion of the public right-of-way for **ten (10) light fixture(s)** for **BLACKWOOD BBQ**, adjacent to the premises known as **962 W. Belmont Ave.**.

Dear Alderman **Thomas Tunney**:

The applicant referenced above has requested the use of the public right-of-way for a **light fixture(s)**. An ordinance has been prepared by the Department of Business Affairs and Consumer Protection – Small Business Center - Public Way Use Unit for presentation to the City Council. Because this request was made for properties located in your ward, as approved by you as per the attached, I respectfully request that you introduce the attached ordinance at the next City Council meeting.

If you have any questions regarding this ordinance, please contact Anthony Bertuca at (312) 744-5506.

Department of Business Affairs and Consumer Protection



City of Chicago



O2015-7713

Office of the City Clerk

Document Tracking Sheet

Meeting Date:	10/21/2015
Sponsor(s):	Moreno (1)
Type:	Ordinance
Title:	Amendment of grant(s) of privilege in public way to 2510 W Armitage Ave
Committee(s) Assignment:	Committee on Transportation and Public Way

ORDINANCE AMENDMENT

Acct. No. 399888 - 1

Permit No. 1119642

BE IT ORDAINED BY THE CITY COUNCIL OF THE CITY OF CHICAGO:

Section 1:

The ordinance passed by the City Council of the City of Chicago for **2501 ARMITAGE, LLC** on **09/24/2015**, and printed upon page **7406** of the Journal of Proceedings of the City of Chicago is here by Amended by deleting the words

“2510 W. Armitage Ave.”

and inserting in their place the words

“2501 West Armitage Avenue”

Section 2:

This ordinance Amendment shall be in effect upon its passage.

ALDERMAN: _____

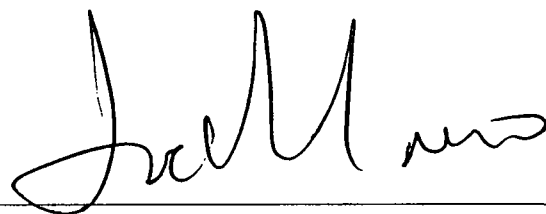

10-21-15

Proco Joe Moreno

Ward: 01

Date:



10/21/2015

Alderman Proco Joe Moreno
Ward # 01
City of Chicago
City Hall, Room 300
121 North LaSalle Street
Chicago, Illinois 60602

Re: An amended ordinance to use and maintain a portion of the public right-of-way for **three (3) canopy(ies)** for **2501 ARMITAGE, LLC**, adjacent to the premises known as **2501 W. Armitage Ave.**.

Dear Alderman Proco Joe Moreno:

The applicant referenced above has requested the use of the public right-of-way for a **canopy(ies)**. An ordinance has been prepared by the Department of Business Affairs and Consumer Protection – Small Business Center - Public Way Use Unit for presentation to the City Council. Because this request was made for properties located in your ward, as approved by you as per the attached, I respectfully request that you introduce the attached ordinance at the next City Council meeting.

If you have any questions regarding this ordinance, please contact Anthony Bertuca at (312) 744-5506.

Department of Business Affairs and Consumer Protection



City of Chicago



O2015-7718

Office of the City Clerk

Document Tracking Sheet

Meeting Date:	10/21/2015
Sponsor(s):	Hopkins (2)
Type:	Ordinance
Title:	Amendment of grant(s) of privilege in public way to Cafe Sushi-Wells
Committee(s) Assignment:	Committee on Transportation and Public Way

ORDINANCE AMENDMENT

**Acct. No. 210982 - 1
Permit No. 1119722**

BE IT ORDAINED BY THE CITY COUNCIL OF THE CITY OF CHICAGO:

Section 1:

The ordinance passed by the City Council of the City of Chicago for **CAFE SUSHI-WELLS** on **09/24/2015**, and printed upon page **7325** of the Journal of Proceedings of the City of Chicago is here by Amended by deleting the words

“Said Awning(s) at W. Greenview St measure(s):

Said Awning(s) at Corner of N. Wells and W. Greenview measure(s):”

and inserting in their place the words

“Said Awning(s) at W. Evergreen Avenue measure(s):

Said Awning(s) at Corner of N. Wells Street and W. Evergreen Avenue measure(s):”

Section 2:

This ordinance Amendment shall be in effect upon its passage.

ALDERMAN: _____

Brian Hopkins

Oct. 21, 2015

Brian Hopkins

Ward: 02 Date:



10/21/2015

Alderman **Brian Hopkins**
Ward # **02**
City of Chicago
City Hall, Room **200**
121 North LaSalle Street
Chicago, Illinois 60602

Re: An amended ordinance to use and maintain a portion of the public right-of-way for **three (3) awning(s)** for **CAFE SUSHI-WELLS**, adjacent to the premises known as **1342 N. Wells St.**.

Dear Alderman **Brian Hopkins**:

The applicant referenced above has requested the use of the public right-of-way for **awning(s)**. An ordinance has been prepared by the Department of Business Affairs and Consumer Protection – Small Business Center - Public Way Use Unit for presentation to the City Council. Because this request was made for properties located in your ward, as approved by you as per the attached, I respectfully request that you introduce the attached ordinance at the next City Council meeting.

If you have any questions regarding this ordinance, please contact Anthony Bertuca at (312) 744-5506.

Department of Business Affairs and Consumer Protection



City of Chicago



O2015-7722

Office of the City Clerk

Document Tracking Sheet

Meeting Date:	10/21/2015
Sponsor(s):	Hopkins (2)
Type:	Ordinance
Title:	Amendment of grant(s) of privilege in public way to Jimmy Johns
Committee(s) Assignment:	Committee on Transportation and Public Way

ORDINANCE AMENDMENT

Acct. No. 361790 - 3

Permit No. 1115907

BE IT ORDAINED BY THE CITY COUNCIL OF THE CITY OF CHICAGO:

Section 1:

The ordinance passed by the City Council of the City of Chicago for **Jimmy Johns** on **01/21/2015**, and printed upon page **101957** of the Journal of Proceedings of the City of Chicago is here by Amended by deleting the words "2006 N Clybourn" and inserting in their place the words "2206 N Clybourn"

Section 2:

This ordinance Amendment shall be in effect upon its passage.

ALDERMAN: _____

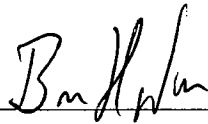

Oct. 21, 2015

Brian Hopkins

Ward: 02

Date:



2nd ATTEMPT AT INTRODUCTION

10/21/2015

Alderman **Brian Hopkins**
Ward # **02**
City of Chicago
City Hall, Room **200**
121 North LaSalle Street
Chicago, Illinois 60602

Re: An amended ordinance to use and maintain a portion of the public right-of-way for **one (1) sign(s)** for **Jimmy Johns**, adjacent to the premises known as **2206 N. Clybourn Ave.**.

Dear Alderman **Brian Hopkins**:

The applicant referenced above has requested the use of the public right-of-way for a **sign(s)**. An ordinance has been prepared by the Department of Business Affairs and Consumer Protection – Small Business Center - Public Way Use Unit for presentation to the City Council. Because this request was made for properties located in your ward, as approved by you as per the attached, I respectfully request that you introduce the attached ordinance at the next City Council meeting.

If you have any questions regarding this ordinance, please contact Anthony Bertuca at (312) 744-5506.

Department of Business Affairs and Consumer Protection



City of Chicago



O2015-7735

Office of the City Clerk

Document Tracking Sheet

Meeting Date:	10/21/2015
Sponsor(s):	Hopkins (2)
Type:	Ordinance
Title:	Amendment of grant(s) of privilege in public way to Restoration Hardware - awnings
Committee(s) Assignment:	Committee on Transportation and Public Way

ORDINANCE AMENDMENT

Acct. No. 401975 - 1

Permit No. 1115958

BE IT ORDAINED BY THE CITY COUNCIL OF THE CITY OF CHICAGO:

Section 1:

The ordinance passed by the City Council of the City of Chicago for **RESTORATION HARDWARE** on **01/21/2015**, and printed upon page **102022** of the Journal of Proceedings of the City of Chicago is here by Amended by deleting the words "**RESTORATION HARDWARE**" and inserting in their place the words "**938 W NORTH AVE, LLC**"

Section 2:

This ordinance Amendment shall be in effect upon its passage.

ALDERMAN: _____

Brian Hopkins

Oct. 21, 2015

Brian Hopkins

Ward: 02

Date:



10/21/2015

Alderman Brian Hopkins
Ward # **02**
City of Chicago
City Hall, Room **200**
121 North LaSalle Street
Chicago, Illinois 60602

Re: An amended ordinance to use and maintain a portion of the public right-of-way for **four (4)** **awning(s)** for **938 W NORTH AVE, LLC**, adjacent to the premises known as **938 W. North Ave.**.

Dear Alderman **Brian Hopkins**:

The applicant referenced above has requested the use of the public right-of-way for a **awning(s)**. An ordinance has been prepared by the Department of Business Affairs and Consumer Protection – Small Business Center - Public Way Use Unit for presentation to the City Council. Because this request was made for properties located in your ward, as approved by you as per the attached, I respectfully request that you introduce the attached ordinance at the next City Council meeting.

If you have any questions regarding this ordinance, please contact Anthony Bertuca at (312) 744-5506.

Department of Business Affairs and Consumer Protection



City of Chicago



O2015-7737

Office of the City Clerk

Document Tracking Sheet

Meeting Date:	10/21/2015
Sponsor(s):	Hopkins (2)
Type:	Ordinance
Title:	Amendment of grant(s) of privilege in public way to Restoration Hardware - canopy
Committee(s) Assignment:	Committee on Transportation and Public Way

ORDINANCE AMENDMENT

Acct. No. 401975 - 1

Permit No. 1115960

BE IT ORDAINED BY THE CITY COUNCIL OF THE CITY OF CHICAGO:

Section 1:

The ordinance passed by the City Council of the City of Chicago for **RESTORATION HARDWARE** on **01/21/2015**, and printed upon page **102034** of the Journal of Proceedings of the City of Chicago is here by Amended by deleting the words "**RESTORATION HARDWARE**" and inserting in their place the words "**938 W NORTH AVE, LLC**"

Section 2:

This ordinance Amendment shall be in effect upon its passage.

ALDERMAN: _____

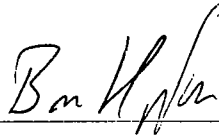

01/21, 2015

Brian Hopkins

Ward: 02

Date:



10/21/2015

Alderman **Brian Hopkins**
Ward # **02**
City of Chicago
City Hall, Room **200**
121 North LaSalle Street
Chicago, Illinois 60602

8

Re: An amended ordinance to use and maintain a portion of the public right-of-way for **one (1) canopy(ies)** for **938 W NORTH AVE, LLC**, adjacent to the premises known as **938 W. North Ave.**.

Dear Alderman **Brian Hopkins**:

The applicant referenced above has requested the use of the public right-of-way for a **canopy(ies)**. An ordinance has been prepared by the Department of Business Affairs and Consumer Protection – Small Business Center - Public Way Use Unit for presentation to the City Council. Because this request was made for properties located in your ward, as approved by you as per the attached, I respectfully request that you introduce the attached ordinance at the next City Council meeting.

If you have any questions regarding this ordinance, please contact Anthony Bertuca at (312) 744-5506.

Department of Business Affairs and Consumer Protection



City of Chicago



O2015-7741

Office of the City Clerk

Document Tracking Sheet

Meeting Date:	10/21/2015
Sponsor(s):	Hopkins (2)
Type:	Ordinance
Title:	Amendment of grant(s) of privilege in public way to Restoration Hardware - light fixtures
Committee(s) Assignment:	Committee on Transportation and Public Way

ORDINANCE AMENDMENT

Acct. No. 396326 - 1

Permit No. 1119675

BE IT ORDAINED BY THE CITY COUNCIL OF THE CITY OF CHICAGO:

Section 1:

The ordinance passed by the City Council of the City of Chicago for **RESTORATION HARDWARE** on **09/24/2015**, and printed upon page **7209** of the Journal of Proceedings of the City of Chicago is here by Amended by deleting the words

“eight (8) Light Fixture(s) projecting over the public right-of-way

Eight (8) at point three three (.33) feet in length, point six six (.66) feet in width and nine hundred ninety-nine thousand nine hundred ninety-nine (0) feet above grade level.”

and inserting in their place the words

“eight (8) Light fixture(s) in the public right-of-way

Eight (8) at four (4) inches in length and four (4) inches in width.

Said light fixtures shall be located in the sidewalk to illuminate existing historical building.”

Section 2:

This ordinance Amendment shall be in effect upon its passage

ALDERMAN: *Brian Hopkins* Oct 21, 2015

Brian Hopkins

Ward: 02 Date:



10/21/2015

Alderman **Brian Hopkins**
Ward # **02**
City of Chicago
City Hall, Room **200**
121 North LaSalle Street
Chicago, Illinois 60602

Re: An amended ordinance to use and maintain a portion of the public right-of-way for **eight (8) light fixture(s)** for **RESTORATION HARDWARE**, adjacent to the premises known as **1306 N. Dearborn St.**

Dear Alderman **Brian Hopkins**:

The applicant referenced above has requested the use of the public right-of-way for **light fixture(s)**. An ordinance has been prepared by the Department of Business Affairs and Consumer Protection – Small Business Center - Public Way Use Unit for presentation to the City Council. Because this request was made for properties located in your ward, as approved by you as per the attached, I respectfully request that you introduce the attached ordinance at the next City Council meeting.

If you have any questions regarding this ordinance, please contact Anthony Bertuca at (312) 744-5506.

Department of Business Affairs and Consumer Protection



City of Chicago



O2015-7744

Office of the City Clerk

Document Tracking Sheet

Meeting Date:	10/21/2015
Sponsor(s):	Burns (4)
Type:	Ordinance
Title:	Amendment of grant(s) of privilege in public way to American Sightseeing/Gray Line Tours
Committee(s) Assignment:	Committee on Transportation and Public Way

ORDINANCE AMENDMENT

Acct. No. 88486 - 13

Permit No. 1101478

BE IT ORDAINED BY THE CITY COUNCIL OF THE CITY OF CHICAGO:

Section 1:

The ordinance passed by the City Council of the City of Chicago for American Sightseeing / Gray Line Tours on **07/25/2012**, and printed upon page **31415** of the Journal of Proceedings of the City of Chicago is here by Amended by deleting the words "American Sightseeing / Gray Line Tours" and inserting in their place the words "**Big Bus Tours Chicago**"

Section 2:

This ordinance Amendment shall be in effect upon its passage.

ALDERMAN:

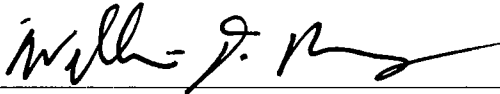

10/21/2015

William D. Burns

Ward: 04

Date:



2nd ATTEMPT AT INTRODUCTION

06/17/2015

Alderman **William D. Burns**
Ward # **04**
City of Chicago
City Hall, Room **305**
121 North LaSalle Street
Chicago, Illinois 60602

Re: An amended ordinance to use and maintain a portion of the public right-of-way for **one (1) booth(s)** for **Big Bus Tours Chicago**, adjacent to the premises known as **1200 S. Lake Shore Dr.**

Dear Alderman **William D. Burns**:

The applicant referenced above has requested the use of the public right-of-way for a **booth(s)**. An ordinance has been prepared by the Department of Business Affairs and Consumer Protection – Small Business Center - Public Way Use Unit for presentation to the City Council. Because this request was made for properties located in your ward, as approved by you as per the attached, I respectfully request that you introduce the attached ordinance at the next City Council meeting.

If you have any questions regarding this ordinance, please contact Anthony Bertuca at (312) 744-5506.

Department of Business Affairs and Consumer Protection



City of Chicago



O2015-7748

Office of the City Clerk

Document Tracking Sheet

Meeting Date:	10/21/2015
Sponsor(s):	Burnett (27)
Type:	Ordinance
Title:	Amendment of grant(s) of privilege in public way to Nebel, Inc.
Committee(s) Assignment:	Committee on Transportation and Public Way

ORDINANCE AMENDMENT

Acct. No. 398609 - 1

Permit No. 1118941

BE IT ORDAINED BY THE CITY COUNCIL OF THE CITY OF CHICAGO:

Section 1:

The ordinance passed by the City Council of the City of Chicago for **Nebel Inc** on **07/29/2015**, and printed upon page **3831** of the Journal of Proceedings of the City of Chicago is here by Amended by deleting the words

“the sum of eight hundred (\$800.00) per annum in advance.”

and inserting in their place the words

“the sum of zero dollars.

Building was built before 1922.”

Section 2:

This ordinance Amendment shall be in effect upon its passage.

ALDERMAN:

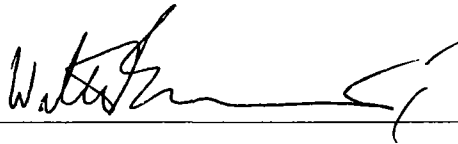

10-21-15

Walter Burnett Jr.

Ward: 27

Date:



City of Chicago



O2015-7747

Office of the City Clerk

Document Tracking Sheet

Meeting Date:	10/21/2015
Sponsor(s):	Sposato (38)
Type:	Ordinance
Title:	Amendment of grant(s) of privilege in public way to Irving Narragansett Partnership
Committee(s) Assignment:	Committee on Transportation and Public Way

ORDINANCE AMENDMENT

Acct. No. 397434 - 1

Permit No. 1118153

BE IT ORDAINED BY THE CITY COUNCIL OF THE CITY OF CHICAGO:

Section 1:

The ordinance passed by the City Council of the City of Chicago for **IRVING NARRAGANSETT PARTNERSHIP** on **09/24/2015**, and printed upon page **7149** of the Journal of Proceedings of the City of Chicago is here by Amended by deleting the words

“5635 W. Montrose Ave.”

and inserting in their place the words

“5625 West Montrose Avenue”

Section 2:

This ordinance Amendment shall be in effect upon its passage.

ALDERMAN:



Nicholas Sposato

Ward: 38

Date:



10/21/2015

Alderman Nicholas Sposato
Ward # **38**
City of Chicago
City Hall, Room **200**
121 North LaSalle Street
Chicago, Illinois 60602

Re: An amended ordinance to use and maintain a portion of the public right-of-way for **one (1) sign(s)** for **IRVING NARRAGANSETT PARTNERSHIP**, adjacent to the premises known as **5625 W. Montrose Ave.**.

Dear Alderman **Nicholas Sposato**:

The applicant referenced above has requested the use of the public right-of-way for a **sign(s)**. An ordinance has been prepared by the Department of Business Affairs and Consumer Protection – Small Business Center - Public Way Use Unit for presentation to the City Council. Because this request was made for properties located in your ward, as approved by you as per the attached, I respectfully request that you introduce the attached ordinance at the next City Council meeting.

If you have any questions regarding this ordinance, please contact Anthony Bertuca at (312) 744-5506.

Department of Business Affairs and Consumer Protection



City of Chicago



O2015-7749

Office of the City Clerk

Document Tracking Sheet

Meeting Date:	10/21/2015
Sponsor(s):	Reilly (42)
Type:	Ordinance
Title:	Amendment of grant(s) of privilege in public way to Fairfield Inn & Suites-Downtown Chicago
Committee(s) Assignment:	Committee on Transportation and Public Way

ORDINANCE AMENDMENT

**Acct. No. 200738 - 1
Permit No. 1119428**

BE IT ORDAINED BY THE CITY COUNCIL OF THE CITY OF CHICAGO:

Section 1:

The ordinance passed by the City Council of the City of Chicago for **FAIRFIELD INN & SUITES - DOWNTOWN CHICAGO** on **09/24/2015**, and printed upon page **7127** of the Journal of Proceedings of the City of Chicago is here by Amended by deleting the words

“Four (4) Light fixture(s) projecting over the public right-of-way

Four at one (1) foot in length, one (1) foot in width and nine hundred ninety-nine thousand nine hundred ninety-nine (0) feet above grade level.”

and inserting in their place the words

“Four Light Fixture(s) in the public right-of-way

Four at one (1) foot in diameter. Existing light fixtures are located in the Sidewalk.

Section 2:

This Ordinance Amendment shall be in effect upon its passage.

ALDERMAN: _____

Brendan Reilly

Ward: **42** Date:

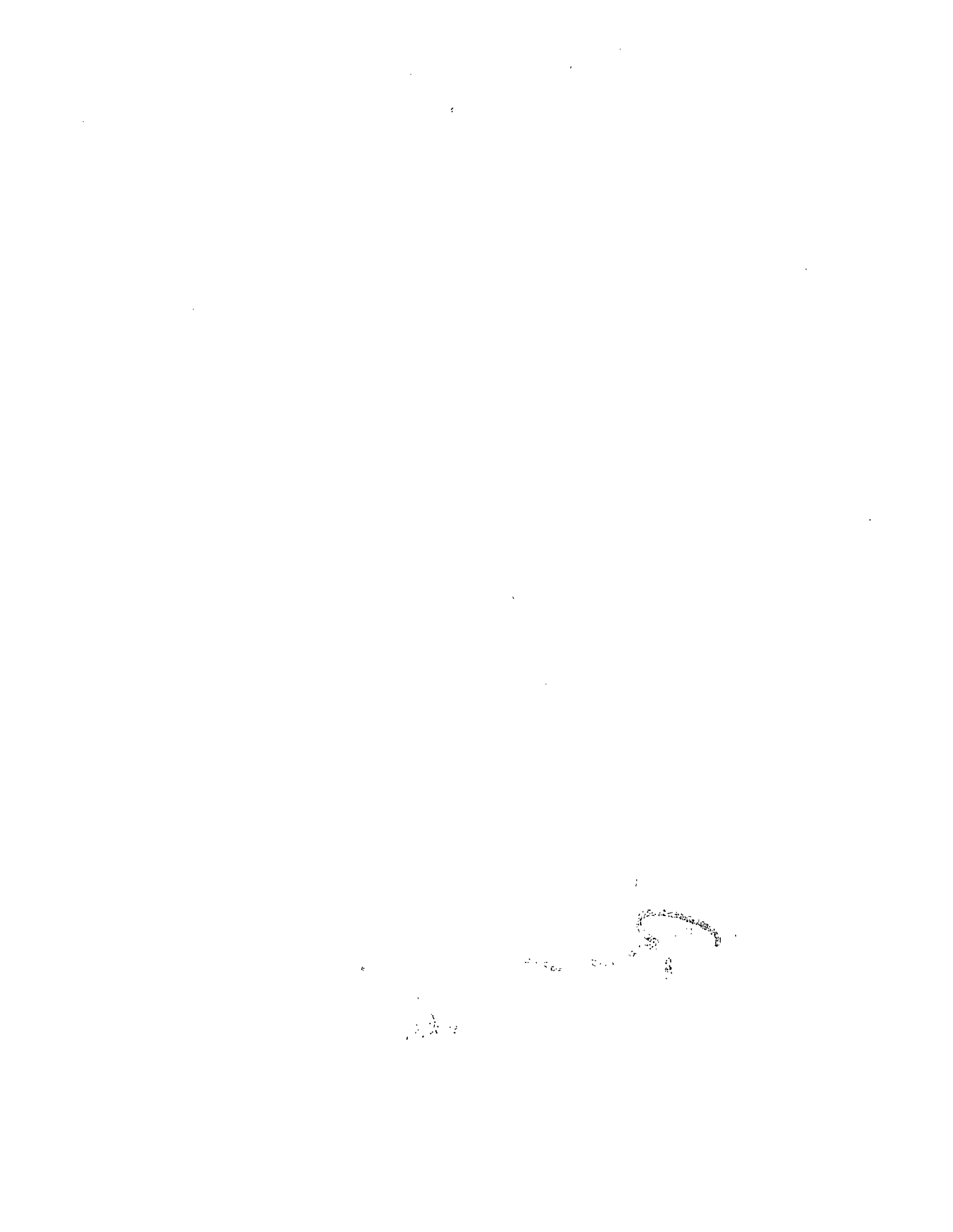



City of Chicago



O2015-7778

Office of the City Clerk

Document Tracking Sheet

Meeting Date: 10/21/2015

Sponsor(s): Moreno (1)
Smith (43)
Hopkins (2)
Moore (49)
Osterman (48)
Cappleman (46)
Sadlowski Garza (10)
Pawar (47)
O'Connor (40)
Dowell (3)
Arena (45)
Burns (4)

Type: Ordinance

Title: Amendment of Municipal Code Chapter 2-32 by adding new Section 2-32-627 establishing Property Tax Relief Program

Committee(s) Assignment: Committee on Finance

Budget Finance

ORDINANCE

PROPERTY TAX INCREASE AND TAX RELIEF PROGRAM 2015

WHEREAS, the City of Chicago is facing a massive budget shortfall in four pension plans and a pension deficit of up to \$550 million that must be paid December 2015; and

WHEREAS, in 2014, the City collected \$824 million in property taxes and roughly \$478 million went to payments for the four city pension funds: Police, Fire, Municipal, and Laborers; and

WHEREAS, on May 12, 2015, Moody's Investors Service announced it lowered the City of Chicago's credit rating to non-investment, or junk bond, status as a result of unfunded pension obligations; and

WHEREAS, there is a dire need for additional revenue to fulfill pension debt obligations; and

WHEREAS, by not funding pension liabilities, the debt will continue to grow and affect Chicago's fiscal operations and impact expenditures for critical areas such as education, public welfare, and infrastructure; and

WHEREAS, to fulfill obligations Chicago must raise additional revenue to address the city's financial liabilities; and

WHEREAS, increasing the property tax rate in the City may provide the financial soundness to pay for the city's fiscal obligations; and

WHEREAS, working families are already financially burdened and a significant property tax increase could harm them substantially; and

WHEREAS, to ease this burden the City will provide temporary property tax relief assistance to the hardest hit households; and

WHEREAS, in order to assist low and middle income families negatively affected by a property tax increase, the City of Chicago will institute a Property Tax Relief Program;

NOW, THEREFORE,

BE IT ORDAINED BY THE CITY COUNCIL OF THE CITY OF CHICAGO:

SECTION 1. The above recitals are expressly incorporated herein and made part hereof as though fully set forth herein.

SECTION 2. Chapter 2-32 of the Municipal Code of Chicago is amended by adding a new Section 2-32-627 as follows:

2-32-627 Property tax relief program.

(a) As used in this Section:

"Applicable year" means the calendar year for which a Homeowner has received a final real estate tax bill that exceeds the final real estate tax bill for the immediately preceding year;

"Assessed value" means the equalized assessed value set for Real estate tax purposes, as determined by the Office of the Cook County Assessor or the Cook County Board of Review;

"Base City's real estate tax assessment rate" is the fraction of the levy for the immediately preceding taxable year divided by the current taxable year's equalized assessed value, which when multiplied by the Equalized Assessed value of a property would determine the amount of money a Homeowner would pay for their portion of City of Chicago real estate taxes absent a change in the tax levy.

"Chief Financial Officer" means the Chief Financial Officer of the City of Chicago or his or her designee.

"City's real estate tax assessment rate" is that fraction which is multiplied by the Assessed value of the property to determine the amount of money the Homeowner must pay for his City of Chicago portion of his Real estate taxes.

"Eligible Homeowner" means a Homeowner who has adjusted gross income in the applicable year under \$100,000.

"Homeowner" means an individual who, at the time of the application and since January 1 of the calendar year immediately preceding the applicable year: (i) is the owner of record of or has a legal or equitable interest, except for a leasehold interest that is not a residential cooperative, in property in this city that is used by the individual as the individual's principal place of residence; and (ii) is liable for paying the Real estate taxes on the property. For purposes of the definition of "homeowner," an equitable interest shall include a beneficial interest in property that is held in an Illinois land trust;

"Household" means the Homeowner, the spouse of the Homeowner if the spouse filed a joint federal income tax return with the Homeowner for the applicable year, and all persons using the residence of the Homeowner as their principal place of residence;

"Household income" means the combined income of the members of a Household

for the applicable year;

"Real estate taxes" means the taxes on real property for which a Homeowner is liable under the Property Tax Code, 35 ILCS 200/1-1 *et seq.*; and

"Real estate tax increase" means the amount by which the total Real estate taxes payable in the applicable year exceeds the total Real estate taxes payable in the immediately preceding taxable year.

(b) The Chief Financial Officer is authorized to establish and administer a property tax relief program under this section for the purpose of providing assistance to certain Homeowners whose Real estate tax liability has significantly risen, particularly relative to their Household incomes as provided in this section. Under this program, a Homeowner who meets the eligibility requirements for a grant under this section may receive a grant in the amount specified in this section. A Homeowner shall be eligible for a grant under this section for that portion of an increase in taxes attributable to an increase in the tax rate assessed for the City of Chicago, and not for that portion attributable to either an increase in assessed value or an increase in tax rate of another taxing body.

(c) The relief the Homeowner is entitled to would be calculated as follows:

1. Start with 100,000 and subtract Household income
2. Take this result and divide by 100,000 to get the rebate rate
3. Multiply the rebate rate times the difference between the City's Real estate tax assessment rate for the applicable year and the City's Base real estate tax assessment rate.
4. Multiply this number by the Assessed value.

(c)(1) Additional relief will be provided to a Homeowner who is 60 years of age or older, who has resided in their household for 18 years or longer, and whose assessed value has increased by 30% or more from the prior tax year. Homeowners who are eligible for the Senior Citizens Assessment Freeze homestead exemption or the Homestead Improvement Exemption are not eligible for this relief. This additional relief would be calculated as follows:

1. Subtract the percentage increase of total equalized assessed value for the City of Chicago from the percentage increase in the homeowner's equalized assessed value to get the Long Term Homeowner supplemental relief rate
2. Multiply this supplemental relief rate by the difference between the City's Real estate tax assessment rate for the applicable year and the City's Base real estate tax assessment rate
3. Multiply this number by the Equalized Assessed Value.
4. Add this amount to the relief provided under Section (c) to determine the total amount of relief.

(d) A Homeowner must file an application to participate in the relief program with the Department of Finance. The application must be on a form prescribed by the Chief

Financial Officer and include evidence of the Homeowner's Household income for the applicable year, evidence that the applicant became the Homeowner prior to January 1st of the calendar year immediately preceding the applicable year, evidence of the amount of the Homeowner's Real estate tax increase.

(e) The provisions of Section 2-156-110 of this Code does not apply to City employees with respect to their participation in the property tax relief program created pursuant to this section.

(f) The Chief Financial Officer is authorized to expend legally available funds for the implementation of this section. However, the program created pursuant to this section will be suspended at any time that no funds are legally available for the program. The Chief Financial Officer also is authorized to enter into agreements and execute documents necessary to implement this section, to promulgate rules and regulations necessary to implement this section and to prescribe application forms and other forms necessary to elicit relevant information concerning participants in the property tax relief program. The Chief Financial Officer may request the Office of Compliance to conduct audits to determine eligibility of an applicant to participate in the property tax relief program created pursuant to this section. Any personal financial information provided to the City in connection with an application submitted under this section shall remain confidential.

(g) This Section will be effective for five tax years after its effective date.

SECTION 3. This ordinance takes effect upon its passage and approval.

*with D-1
(4)*

Jeff Mauer 37

Ben Hupker 2

Maria Lopez 3

Joseph A. Yoon 49

[Signature] 48

James Appleman 46

Susan Sedlow 40

Ann Taw 47

[Signature] 40
Pat Dowell 38

[Signature] 45

will

will

will



City of Chicago

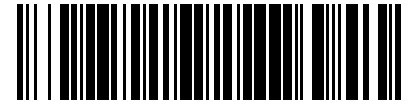

O2015-7779

Office of the City Clerk

Document Tracking Sheet

Meeting Date: 10/21/2015

Sponsor(s): Moore (17)
Villegas (36)
Napolitano (41)
Moreno (1)
Foulkes (16)
Curtis (18)
Sawyer (6)
Moore (49)
Lopez (15)
Cappleman (46)
Pawar (47)
Arena (45)
Ramirez-Rosa (35)
Silverstein (50)
Mitchell (7)
Zalewski (23)
Munoz (22)
Scott, Jr. (24)
Mitts (37)
Reilly (42)
Sposato (38)
Tunney (44)

Type: Ordinance

Title: Amendment of Municipal Code Chapter 2 by establishing new Chapter 2-174 entitled City of Chicago Equal Access Initiative

Committee(s) Assignment: Committee on Committees, Rules and Ethics

PROPOSED ORDINANCE
AMENDMENT

Sponsored by

THE HONORABLE DAVID MOORE

Co-sponsored by

THE HONORABLE GILBERT VILLEGAS

ORDINANCE ESTABLISHING THE
CITY OF CHICAGO EQUAL ACCESS INITIATIVE

BE IT ORDAINED, Pursuant to City of Chicago's home rule authority under Article VII, Section 6(a) of the 1970 Constitution of the State of Illinois, by the City Council of the City of Chicago ("City Council") that Title 2, City Government and Administration, Chapter 2-174, Section 2-174-005 through 2-174-030 are hereby inserted into a newly created Article __, entitled the "*City of Chicago Equal Access Initiative*" and are thereafter amended and renumbered as follows:

ARTICLE __. CITY OF CHICAGO EQUAL ACCESS INITIATIVE

2-174-005. DECLARATION OF POLICY.

It is the policy of the City of Chicago (the "City") to provide equal employment opportunities to all qualified persons without regard to their race, religion, color, age, disability, sex, national origin, sexual orientation, marital status, membership in the military reserves, creed, ancestry, arrest or conviction record, or use or nonuse of lawful products away from work. In adhering to this policy, the City complies with the Illinois Human Rights Act, Title VII of the Civil Rights Act of 1964, as amended, the Americans with Disabilities Act of 1990, and other applicable statutes and regulations relating to equal employment opportunities. The City Council hereby declares that the City of Chicago is a *Majority Minority City* where almost 62% of the City's population and therefore taxpayers are minority -- African Americans make up 32.9% of the City's population and Hispanics make up 28.9% of the City's population. The City is an employer that values the diversity of its employees and as such seeks to achieve the goal of hiring and maintaining an overall City workforce of 60% minority in every City department including the Chicago Police Department and Chicago Fire Department. This policy represents the City's commitment to a nondiscriminatory work environment for all qualified applicants and employees.

2-174-010. DEFINITIONS.

In this Article __ entitled "City of Chicago Equal Access Initiative" --

discrimination resulting in a competitive disadvantage or decreased opportunities to do business with the City.

2-174-015. OFFICE OF DIVERSITY AND OUTREACH.

There is established an Office of Diversity and Outreach that shall be budgeted as a department under the Department of Human Resources and shall maintain at least ten (10) full time equivalents ("FTE"), office space and all other reasonable expenditures needed for the purpose of promoting the importance, benefit and necessity of maintaining diversity within the City's workforce and ensuring compliance with applicable policies, ordinances, statutes, laws and executive orders. With the express goal of achieving an overall City workforce of 60% minority, this Office shall have the following authority and duties pertinent thereto, including but not limited to:

a. Reviewing and assisting the development of diversity, equal employment opportunity, equal access initiative plans of the various City departments including the Chicago Police Department and the Chicago Fire Department to ensure that each plan is consistent with the overall City plan.

b. Maintaining and reporting to the City Council on a quarterly basis statistics, which include, but are not limited to, the proportion of underrepresented group members at all levels and job classifications in the City's workforce and the availability of qualified underrepresented group members in the labor force of the relevant labor areas. The statistics shall indicate how each group has been affected by new hires, training opportunities, promotions, discipline and terminations. A presentation should be made to City Council on February 1st of every year.

c. Counseling employees, managers and others about diversity, equal employment opportunity and equal access initiative issues in the workplace.

d. Facilitating diversity related training programs and workplace mediation.

e. Receiving and investigating complaints of discriminatory employment practices, workplace violence, or of harassment in the workplace from City employees. If an investigation discloses a violation has occurred, the Diversity and Outreach Officer as herein defined shall work with department chiefs, department heads, and managers to implement corrective action and resolve the situation.

f. Receiving and filing investigating complaints with the City's Inspector General regarding any employee or applicant who believes that he or she has been discriminated against by the City.

g. Identifying and maintaining comprehensive and effective recruitment methods that promote a diverse workforce.

h. Monitoring results of all training, with emphasis on minority recruits.

i. Participating in performance examinations, job fairs, and recruitment activities at high schools, universities, law schools, chambers of commerce and other locations.

j. Reviewing all State of Illinois and federal laws, rules and regulations concerning equal employment opportunities to ensure compliance.

k. Direct participation in the hiring, termination and promotion of each employee of the City including employees of the Chicago Police Department and the Chicago Fire Department to determine whether such hiring, termination or promotion is promoting this Ordinance's goal of achieving an overall City workforce of 60% minority.

2-174-020. DIVERSITY AND OUTREACH OFFICER.

The Mayor of the City of Chicago with the advice and consent of a majority of the City Council shall appoint the Diversity and Outreach Officer to a term of six (6) years. The Diversity and Outreach Officer may be removed by a majority vote of the City Council. The Diversity and Outreach Officer shall manage the day-to-day operations of the Office of Diversity and Outreach; perform complaint intake functions; investigate complaints; serve as the City's Americans with Disabilities Act coordinator; directly participate in the hiring, termination and promotion of each employee of the City including employees of Chicago Police Department and Chicago Fire Department; ensure compliance with applicable ordinances, statutes, laws and executive orders; have responsibility and authority for the development and implementation of a comprehensive diversity, equal employment opportunity and equal access initiative plan for the City including the Chicago Police Department and the Chicago Fire Department; and function as the liaison between the City and the media and the community.

2-174-025. DEPARTMENT DIVERSITY, EQUAL EMPLOYMENT OPPORTUNITY AND EQUAL ACCESS INITIATIVE PLANS.

Beginning thirty (30) days after the effective date of this Ordinance, each City department including the Chicago Police Department and the Chicago Fire Department shall submit and present to the City Council and the Diversity and Outreach Officer its present racial employment make-up and its diversity, equal employment opportunity and equal access initiative plan to achieve in their department or offices (including the Chicago Police Department and the Chicago Fire Department) a workforce of 60% minority. Thereafter, each City department including the Chicago Police Department and the Chicago Fire Department shall submit and present every year to the City Council and the Diversity and Outreach Officer its racial make-up for that fiscal year and its diversity, equal employment opportunity and equal access initiative plan to achieve in their department including the Chicago Police Department and the Chicago Fire Department a workforce of 60% minority.

2-174-030. IMPLEMENTATION.

a. *Recruitment.* In collaboration with the Diversity and Outreach Officer, the Director of Human Resources shall practice comprehensive and inclusive advertising and recruiting efforts, which may include special recruiting targeting previously underrepresented groups in addition to traditional recruiting methods (with great emphasis on identifying qualified minority candidates to serve in Chicago Police Department and Chicago Fire Department), and report such recruitment findings to the City Council every year.

b. *Training.* In collaboration with the Diversity and Outreach Officer, the Director of Human Resources shall develop training plans and programs, including on-the-job training, designed to develop the knowledge, skills and abilities essential for developing each employee's fullest potential. The Diversity and Outreach Officer shall develop and provide relevant training to each City department including the Chicago Police Department and Chicago Fire Department to increase employees' knowledge and awareness of laws and regulations, as well as the City's policies relating to diversity, equal employment opportunity, equal access initiative and respecting diversity in the workplace. The Director of Human Resources shall report their training findings to the City Council each year.

c. *Testing, Selection, Placement and Promotion.* The Diversity and Outreach Officer shall review the City testing, selection, placement and promotion policies of each department including Chicago Police Department and Chicago Fire Department to ensure that they comply with applicable laws and regulations relating to the goal achieving a workforce consisting of 60% minority.

d. *Union Contracts.* The Office of Diversity and Outreach Diversity shall review every existing union contract of each department of each bargaining unit including Chicago Police Department and Chicago Fire Department to ensure that each contract complies with applicable laws and regulations relating to the goal of achieving a workforce consisting of 60% minority. The Diversity and Outreach Officer shall have the authority to terminate any union contract that fails to meet the herein stated goals.

Sponsor

David Moore

June 17th

[Signature] 21st

[Signature]
Rochelle (6)

[Signature] 45

[Signature]

Paul Scott 24

[Signature] 42

Co-Sponsor

Gilbert Villegas

[Signature] 36th 1st

Joe Mero

Debra 18

People & More 49

James Caplan 40

[Signature] 41

Carl January 35

Debra Lee 50

Rob Miller 22

Melissa 23

Ernest 37

Nick 38

[Signature]

1. 1000

2. 1000

3. 1000

SPONSOR

David Moore

17TH

21ST

26th

35

45

24
42

Co-Sponsor

Gilbert Villegas

36th 1st

Joe M... 18

49

46

41

35

50

22

23

37

38th

41

Sponsor

David Moore

4/17/17 17TH

[Signature] 21ST

[Signature] 46

[Signature] (6)

[Signature] 15

[Signature] 45

[Signature] 24

[Signature] 42

Co-Sponsor

Gilbert Villegas

[Signature] 36TH 1-1

Ive M... 20

[Signature] 18

[Signature] 49

[Signature] 46

[Signature] 41

Carl January 35

[Signature] 50

[Signature] 22

[Signature] 23

[Signature] 37

[Signature] 38

[Signature]



City of Chicago



O2015-7697

Office of the City Clerk

Document Tracking Sheet

Meeting Date: 10/21/2015

Sponsor(s): Cochran (20)

Type: Ordinance

Title: Amendment of Municipal Code Section 9-68-020 concerning residential parking permit placards for aldermen and aldermanic staff

Committee(s) Assignment: Committee on Pedestrian and Traffic Safety

Traffic

ORDINANCE

BE IT ORDAINED BY THE CITY COUNCIL OF THE CITY OF CHICAGO:

SECTION 1. Section 9-68-020 of the Municipal Code of Chicago is hereby amended by deleting the language struck through and by inserting the language underscored, as follows,

9-68-020 Residential parking permits.

(Omitted text is not affected by this ordinance)

(b-1) Upon application and payment of the required fee to the city clerk, the clerk or his designee shall issue one annual residential parking permit placard (for purposes of this subsection, "placard") to any alderman. The placard shall be issued in such format that enables easy transferability from one vehicle to another vehicle, and it must include the ward's number and a unique identification number. The placard can be used to park any vehicle in any residential parking permit zone in the alderman's ward or in any ward adjacent to the alderman's ward when such vehicle is used by the alderman or his aldermanic staff for the performance of official city business. When in use, the placard must be conspicuously displayed on the dashboard of the vehicle. The fee for issuing a placard shall be \$200.00 per year. Any alderman or his aldermanic staff shall immediately report to the city clerk the loss or theft of any placard. A misuse of a residential parking placard by any alderman or his aldermanic staff shall be deemed to be a violation of Section 2-156-060 of this Code. In addition to any applicable penalty, any person who uses a false, lost, stolen or altered placard shall be fined not less than \$500.00 nor more than \$1,000.00 for each offense.

(Omitted text is not affected by this ordinance)

(f) Except as otherwise provided in subsection (b-1) of this section, it shall be unlawful for any person to affix, cause to be affixed, or otherwise display any residential parking permit or other vehicle-specific permit issued pursuant to any other parking permit program to any automobile other than the vehicle to which the permit was intended to be affixed at the time of issuance by the city.

(Omitted text is not affected by this ordinance)

(j) Except as otherwise provided in subsections (b-1) and (g) of this section, any person violating any of the provisions of this section shall be fined not less than \$200.00 nor more than \$500.00 for each offense, and each day such a violation continues shall be deemed a separate and distinct offense.

(Omitted text is not affected by this ordinance)

SECTION 2. This ordinance shall take effect upon passage and publication.

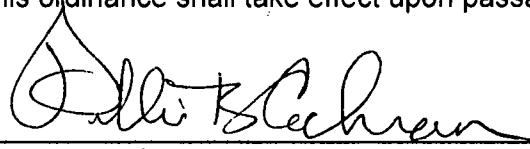
A handwritten signature in black ink, appearing to read "Willie Cochran", written over a horizontal line.

Willie Cochran
Alderman, 20th Ward



City of Chicago

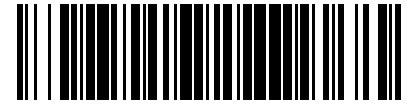

O2015-7755

Office of the City Clerk

Document Tracking Sheet

Meeting Date:	10/21/2015
Sponsor(s):	Solis (25)
Type:	Ordinance
Title:	Amendment of Municipal Code Section 9-64-205 by further regulating parking meters and hours of operation on portion of S Archer Ave, removal of meters on portion of W Taylor St and installation of meters on portion of S Canalport
Committee(s) Assignment:	Committee on Pedestrian and Traffic Safety

Traffic

October 21, 2015

BE IT ORDAINED BY THE CITY COUNCIL OF THE CITY OF CHICAGO:

SECTION 1. The Comptroller of the City of Chicago is directed to remove parking meters at:

- West Taylor Street, south side of the street, from South Clinton Street heading east approximately 105 feet (495-517 W. Taylor Street)

SECTION 2. The Comptroller of the City of Chicago is directed to install parking meters at:

- 2100 block of South Canalport, both sides of the street
- South Archer Avenue, both sides of the street, from West Cermak Road to South Stewart Avenue

SECTION 3. Section 9-64-206 of the Municipal Code is hereby amended by adding the language underscored and by deleting the language struck through as follows:

9-64-205 Parking meters—hours of operation

Notwithstanding any prior ordinance establishing different hours of operation, the hours of operation for a parking meter shall be as follows:

(Omitted text is unaffected by this ordinance)

(e) Notwithstanding the days and hours of operation in subsections (a), (b), (c), and (d) of this section, parking meters shall operate:

(1) From 8 a.m. to 10 p.m., Monday through Sunday on:

25.1- South Archer Avenue, both sides of the street, from West Cermak Road to South Stewart Avenue

(f) The time limits set forth above shall not replace any other more restrictive parking or standing restrictions and do not relieve a person from the duty to observe other and more restrictive provisions prohibiting or limiting the standing or parking of vehicles in specified places or at specified times.

SECTION 4. This ordinance shall be in full force and effect from and after the date of its passage and approval.



Daniel S. Solis
Alderman, 25th Ward



City of Chicago

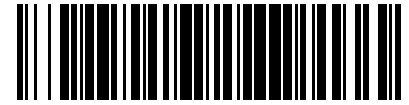

O2015-7719

Office of the City Clerk

Document Tracking Sheet

Meeting Date: 10/21/2015

Sponsor(s): Ramirez-Rosa (35)
Waguespack (32)
Sposato (38)
Arena (45)
Foulkes (16)
Sadlowski Garza (10)
Moore (17)
Munoz (22)
Sawyer (6)
Hairston (5)

Type: Ordinance

Title: Amendment of Municipal Code Chapters 3-12 and 11-12 by establishment of stormwater stress user fee

Committee(s) Assignment: Committee on Finance

FINANCE

ORDINANCE

STORMWATER STRESS FEE

WHEREAS, the City of Chicago is a home rule unit of government as defined in Article VII, Section 6 (a) of the Illinois Constitution, and, as such, may exercise any power and perform any function pertaining to its government and affairs.

WHEREAS, stormwater is the only major infrastructure system in the City that is currently not paid for through user fees.

WHEREAS, more than \$773 million was paid out in over 181,000 flood related insurance claims in Cook County between 2007 and 2011. And whereas, 10 of the 23 zip codes with the highest number of aggregated claims also fell within the ZIP codes with the highest levels of impervious surface.

BE IT ORDAINED BY THE CITY COUNCIL OF CHICAGO, AS FOLLOWS:

Section 1. Purpose.

The purpose of this Ordinance is to provide a stormwater stress user fee for water users in the City of Chicago. To the extent that the provisions of this Ordinance conflict with any prior Ordinance or provision of the City, this Ordinance shall control.

Section 2. Definitions.

SECTION 1. Chapter 11-12 of the Municipal Code of Chicago is amended by adding a new Section 11-12-325, as follows:

11-12-325 Stormwater Stress Fee

(a) As used in this section:

"City" means the City of Chicago.

"Impervious Surface" means a surface which substantially precludes the infiltration of water, such as concrete, asphalt, tile or compacted gravel.

"Eligible properties" means properties that are currently billed by the Department of Water Management for water and sewer services.

"Fee" means a monthly stormwater stress user fee to be added to eligible properties' monthly water bills.

(b) The Department of Water Management is authorized to establish and administer a stormwater stress fee program under this section. Under this program, owners whose properties meet the eligibility requirements for stormwater stress fee collection may be charged a fee in the amount specified in Section 3.

Section 3-1 Method of Computing and Reflecting Stormwater Stress for Residential Properties

Commencing in 2017, the City will collect a monthly stormwater stress fee on eligible properties.

The Department of Water Management will be responsible for auditing the sewer fund and determining exactly how much of the sewer fund is allocated annually towards stormwater management.

The Department of Water Management will determine the median square feet of impervious surface area for single family homes in the city. This shall be defined as an "equivalent residential unit" (ERU) and will be the base billing unit for the stormwater stress fee.

The Department of Water Management will set a billing rate for single-family detached residences and single-family attached residences that will be calculated as follows:

$$\frac{SWM_R}{ERU_R}$$

Where:

SWM_R = Annual Stormwater Management Cost for all single-family detached and single-family attached residential properties in the City of Chicago

ERU_R = Equivalent Residential Units for all single-family detached residences and single-family attached residences in the City of Chicago

Thus, if the annual stormwater management cost for all single-family detached and single-family attached residential properties in the City of Chicago was determined to be \$10,000,000 and it is determined that there are 500,000 ERUs for all single-family detached residences and single-family attached residences in the city, the rate for the stormwater stress fee would be \$20 per ERU. Single-family detached residences and single-family attached residences will all be assumed to have an ERU of 1.0 and their fee will be assessed accordingly.

Section 3-2 Method of Computing and Reflecting Stormwater Stress for Non-Residential Properties

Properties other than single-family detached residences and single-family attached residences will be charged a stormwater stress fee that will be calculated as follows:

$$\frac{SWM_C}{ERU_C}$$

Where:

SWM_C = Annual Stormwater Management Cost for all non single-family detached and single-family attached residential properties in the City of Chicago

ERU_C = Equivalent Residential Units for all non single family detached residences and single-family attached residences in the entirety of the City of Chicago

Thus, if the stormwater management cost for all non single-family detached and single-family attached residential properties in the city was determined to be \$40,000,000 and it is determined that there are 5,000,000 ERUs for all non single-family detached residences and single-family attached residences in the city, the rate for the stormwater stress fee would be \$8 per ERU.

Properties other than single-family detached residences and single-family attached residences will then be charged a stormwater stress fee at the corresponding rate set by the Department of Water Management for each ERU, or fraction thereof, of impervious surface area of the property. (Example: a property consisting of 25,000 ft² of which 10,000 ft² is impervious would pay a stormwater stress fee

computed as follows: 10,000 ft² of impervious surface divided by an ERU of 2,000 ft² equals 5.0; the 5.0 ERU is then multiplied by the rate set by the Department of Water Management.)

Section 4. Implementation, Eligibility and Enforcement

The Department of Water Management of the City of Chicago will assess which properties are subject to fee collection. They will work with the Department of Innovation and Technology to use their Geographic Information Systems program to assess the square footage of impervious surface area on eligible properties in Chicago.

A portion of the fees collected under this ordinance will be used towards implementing the stormwater stress fee program. The remaining funds will be deposited into the sewer fund. The amount in fees deposited into the sewer fund will be deducted from the total amount of funds currently collected under the sewer billing system. This will be reflected by an according decrease in the sewer bill as a percentage of the water bill.

Owners of eligible properties will be held to the liability standards as defined under section 11-12-330 of the Municipal Code of the City of Chicago. All fees are to be enforced as specified in Chapter 11-12, Article V of the Municipal Code of the City of Chicago.

Section 5. Section 3-12-020 of Title 3 of the Municipal Code of Chicago is hereby amended by inserting the underscored language as follows:

3-12-020 Charge for Sewer Service and Use of Sewerage System.

(a). A charge for sewer service and use of the sewerage system of the City of Chicago is hereby established. The charge shall be an amount equal to the percentage set forth in the below Table, of the amount charged for water service pursuant to Chapter 11-12 of this Code, whether such water service is metered or otherwise. The percentages established in the below Table are subject to change when the sewer fund is subsidized by fees collected by the stormwater stress fee program. Provided, however, that:

(Omitted text is unaffected by this ordinance.)

Section 6. Appeals

The Department of Water Management will develop an application form and application process for appeals to the assessed stormwater fee on a property, incorporating requirements as are necessary to effectuate the intent of this Ordinance.

Any owner may file an application with the Department of Water Management contesting the calculation of impervious surface area on the lot as of the date of the application. The applicant must submit satisfactory evidence as required by the Department of Water Management, such as square footage measurements and descriptions of the relevant buildings or materials.

Section 7. Exemptions

Exemptions for sewer fees governed under Section 11-12-540 and Section 3-12-050 of the Municipal Code of the City of Chicago will also be made applicable to the stormwater stress fee. The Department of Water Management will develop an application process for these exceptions, incorporating requirements as are necessary to effectuate the intent of this Ordinance.

Section 8. User Credits

Owners of properties subject to Chapter 11-18 of the Municipal Code of the City of Chicago will be eligible for user credits to offset a portion of their assessed stormwater stress fee. The Department of Water Management will prepare an ordinance, for submission to the City Council, which determines a credits program and an application process for the credits program. Credits given to owners of properties subject to Chapter 11-18 of the Municipal Code of the City of Chicago will be capped at 20% of the assessed stormwater stress fee.

Section 9. Review

The Commissioner of the Department Water Management shall perform an audit of the program one year after it has been enacted. The audit will include an analysis of single-family detached residences' and single-family attached residences' water utility expenses prior to and after the enactment of the program. This analysis will also forecast single-family detached residences' and single-family attached residences' projected water utility expenses from that point forward.

Section 10.

The ordinance shall be in full force and effect from and after its passage and approval.



Carlos Ramirez-Rosa
Alderman, 35th Ward



32



33rd



45

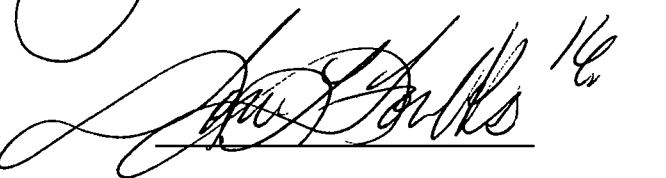

16th

Susan Sablowki Daza¹⁰

W. Me 17

MB Ms 22

Robt (75-6)

Luslie/Huiston 5



City of Chicago

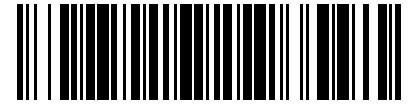

O2015-7693

Office of the City Clerk

Document Tracking Sheet

Meeting Date: 10/21/2015

Sponsor(s): Arena (45)
Beale (9)
Sposato (38)
Munoz (22)
Hairston (5)
Sawyer (6)
Cochran (20)
Moore (17)
Waguespack (32)
Cappleman (46)
Pawar (47)
Silverstein (50)
Lopez (15)
Napolitano (41)
Maldonado (26)
Reboyras (30)
Solis (25)
Foulkes (16)
Dowell (3)
Ramirez-Rosa (35)
Sadlowski Garza (10)

Type: Ordinance

Title: Amendment of Municipal Code Chapters 3-46 and 9-115
concerning regulation and licencing of tax of transportation
network service drivers

Committee(s) Assignment: Committee on Finance

ORDINANCE

BE IT ORDAINED BY THE CITY COUNCIL OF THE CITY OF CHICAGO:

SECTION 1. Chapter 3-46 of the Municipal Code of Chicago is hereby amended by inserting the underscored language as follows:

3-46-030 Tax Imposed.

(Omitted text is unaffected by this ordinance)

(b-1) For ground transportation used in the city to provide transportation network service by transportation network drivers:

- ~~(i) Engaged with a Class A transportation network provider,~~
- ~~(a) \$5.40 for every ride that includes a pickup or drop-off, or both, at O'Hare International Airport, Midway International Airport, Navy Pier, or McCormick Place, and (b) in all other cases, \$0.40 per vehicle per ride accepted;~~

(Omitted text is unaffected by this ordinance)

SECTION 2. Chapter 9-115 of the Municipal Code of Chicago is hereby amended by inserting the underscored language as follows:

(Omitted text is unaffected by this ordinance)

9-115-150 Transportation network drivers – Requirements.

(a) No Class B transportation network provider licensee shall engage any person as a transportation network driver unless the person possesses a valid restricted public chauffeur license issued by the city pursuant to Chapter 9-104 of this Code and rules and regulations promulgated thereto.

(b) (1) No Class A transportation network provider licensee shall engage any person as a transportation network driver unless the licensee ascertains, in a process approved by the commissioner, that the person:

(Omitted text is unaffected by ordinance)

(viii) has no outstanding debt to the City of Chicago and is not in arrears of any child support obligations.

(Omitted text unaffected by this ordinance)

9-115-180 Operating regulations.

(Omitted text is unaffected by this ordinance)

(b) No transportation network driver shall pick up a passenger on any portion of (1) O'Hare International Airport, Midway International Airport, Navy Pier or McCormick Place unless the commissioner determines, in duly promulgated rules, following consultation with the commissioner of aviation, that such ~~pick-ups~~ pickups can be accomplished in a manner that preserves security, public safety, the orderly flow of traffic and compliance with ~~the Metropolitan Pier and Exposition Authority Airport Departure Tax Ordinance or payment of an equivalent tax to the city~~ all applicable tax ordinances; and (2) designated taxicab stands or loading zones.

(c) No transportation network driver shall pick up a passenger on any portion of O'Hare International Airport, Midway International Airport, Navy Pier or McCormick Place unless driver has a valid restricted chauffeur license issued by the City pursuant to Chapter 9-104 and rules and regulations promulgated thereto. Any transportation network driver who serves O'Hare International Airport, Midway International Airport, Navy Pier or McCormick Place shall be deemed to be engaged by a Class B Licensee under Chapter 9-115.

Section 3. This ordinance shall be in force and effect upon its passage and approval.

City all Beale 9th

Nicholas Sparto 38th

Robert Mitz 22

Leslie A. Houston 5

Paul A. J. 66th

Allie Blachon 20

Y. W. 17
J. W. 32

James Appleman 46

Paul J. 10

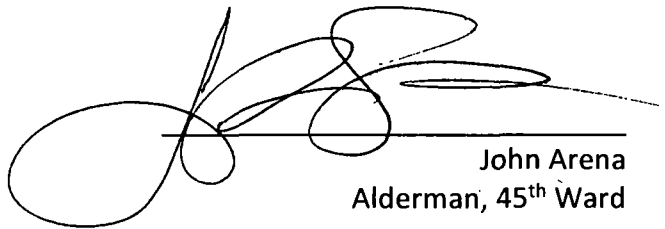

John Arena
Alderman, 45th Ward

Robert M. 26

Daniel J. 25

Paul J. 18

Pat Dowell, 31

Cathy J. 35
Susan J. 10

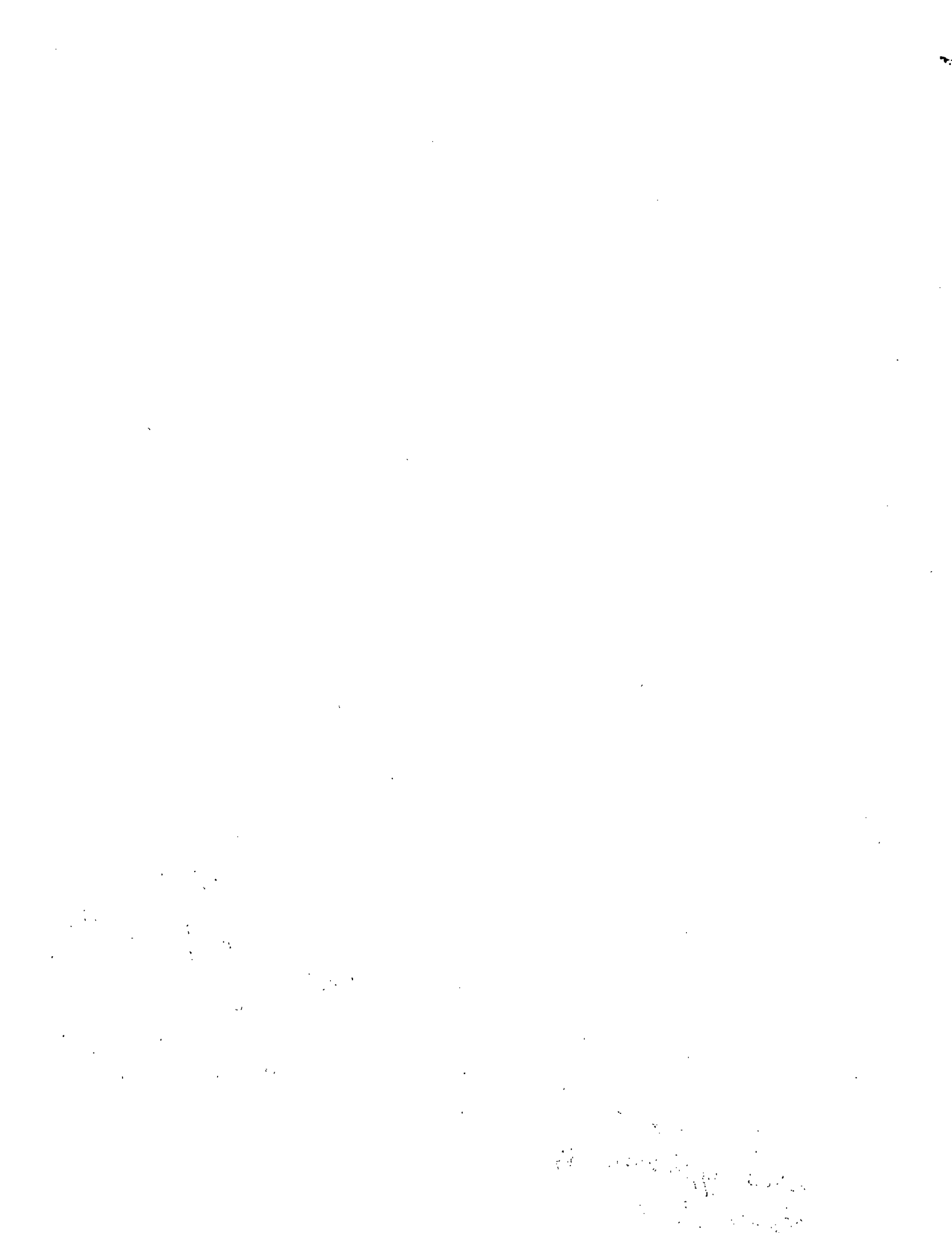



City of Chicago



O2015-7774

Office of the City Clerk

Document Tracking Sheet

Meeting Date: 10/21/2015

Sponsor(s): Arena (45)
Foulkes (16)
Sawyer (6)
Sadlowski Garza (10)
Hairston (5)
Waguespack (32)
Moore (17)
Munoz (22)
Ramirez-Rosa (35)

Type: Ordinance

Title: Amendment of Municipal Code Section 10-28-805 regarding
minimum fee for sidewalk cafe permit

Committee(s) Assignment: Committee on Finance

ORDINANCE

BE IT ORDAINED BY THE CITY COUNCIL OF THE CITY OF CHICAGO:

SECTION 1. Section 10-28-805 of the Municipal Code of Chicago is hereby amended by inserting the underscored language as follows:

10-28-805 Permit required for sidewalk café.

A permit, which shall be known as a sidewalk café permit, shall be required to operate a sidewalk café. A sidewalk café permit shall be valid from March 1st to and including December 1st of the year of its issuance. The fee for a sidewalk café permit shall be determined by the commissioner, taking into account land values, and shall be set forth by regulation. The minimum fee for a sidewalk café permit shall be \$1,200.00.

SECTION 2. This ordinance shall be in force and effect upon passage and approval.

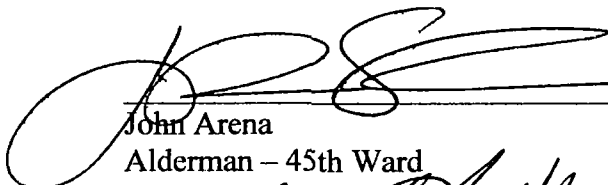

John Arena
Alderman – 45th Ward



Scott Waguespack

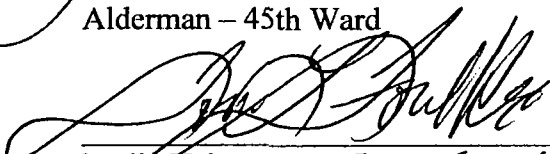

~~Leslie Hairston~~ *TONI FOULKES*
Alderman – ~~5th~~ Ward

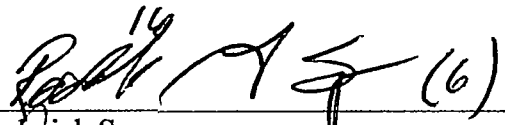

Roderick Sawyer
Alderman – 6th Ward

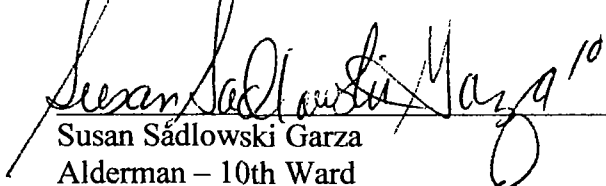

Susan Sadowski Garza
Alderman – 10th Ward

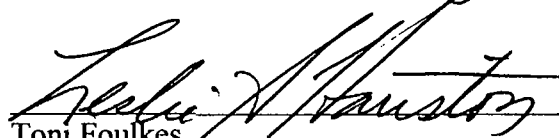

Toni Foulkes
Alderman – 16th Ward



David Moore
Alderman – 17th Ward



Ricardo Munoz
Alderman – 22nd Ward

Chris Taliaferro
Alderman – 29th Ward

Scott Waguespack
Alderman – 32nd Ward



Carlos Ramirez-Rosa
Alderman – 35th Ward

Nicholas Sposato
Alderman – 38th Ward



City of Chicago

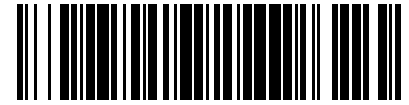

O2015-7776

Office of the City Clerk

Document Tracking Sheet

Meeting Date: 10/21/2015

Sponsor(s): Arena (45)
Hairston (5)
Sawyer (6)
Sadlowski Garza (10)
Foulkes (16)
Moore (17)
Munoz (22)
Waguespack (32)
Ramirez-Rosa (35)
Napolitano (41)
Maldonado (26)

Type: Ordinance

Title: Amendment of Municipal Code Section 4-156-020
concerning amusement tax imposed on admission to artistic
or musical performances

Committee(s) Assignment: Committee on Finance

ORDINANCE

BE IT ORDAINED BY THE CITY COUNCIL OF THE CITY OF CHICAGO:

SECTION 1. Section 4-156-020 of the Municipal Code of Chicago is hereby amended by deleting the struck-through language and inserting the underscored language as follows:

4-156-020 Tax imposed

A. Except as otherwise provided by this article, an amusement tax is imposed upon the patrons of every amusement within the city. The rate of the tax shall be equal to nine percent of the admission fees or other charges paid for the privilege to enter, to witness, to view or to participate in such amusement, unless subsection E of this section provides for a lower rate.

B. The tax imposed by subsection A shall not apply to the following persons or privileges:

(omitted text is unaffected by this ordinance)

~~(g) societies or organizations conducted for the sole purpose of maintaining symphony orchestras, opera performances or artistic presentations, including, but not limited to, musical presentations (“artistic societies or organizations”), if the artistic society or organization (i) receives substantial support from voluntary contributions, (ii) is a not for profit institution where no part of the net earnings inure to the benefit of any private shareholder or person, and (iii) either (a) bears all risk of financial loss from its presentation of the amusement and the amusement is limited to an engagement of not more than eight calendar days over the course of a calendar year or (b) is substantially and materially involved in the production and performance of the amusement. Where an amusement is sponsored or conducted by two or more artistic societies or organizations, the requirements of subsections (i) and (ii) of this subsection 4-156-020(B)(5)(g) must be met by each of such artistic societies or organizations, but the requirements of subsection (iii) may be met by any of such artistic societies or organizations, but the requirements of subsection (iii) may be met by any of such artistic societies or organizations, individually or in combination.~~

(g) any admission to symphony orchestras, opera performances or artistic presentations, including, but not limited to, musical presentations (“artistic societies or organizations”), if admission to such performances is purchased by or facilitated by the Chicago Public Schools or the Chicago Park District for the benefit of children enrolled in public schools or park district programs.

SECTION 2. This ordinance shall be in force and effect upon passage and approval.

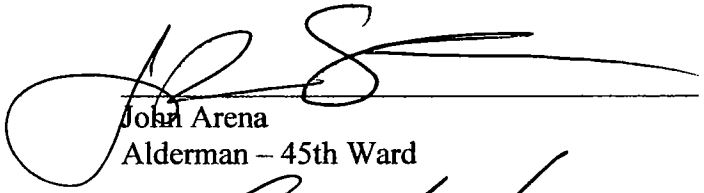

John Arena
Alderman - 45th Ward

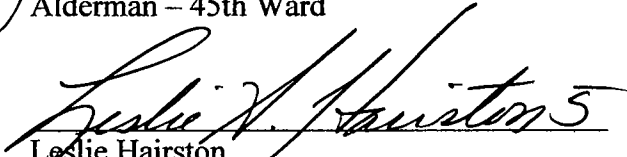

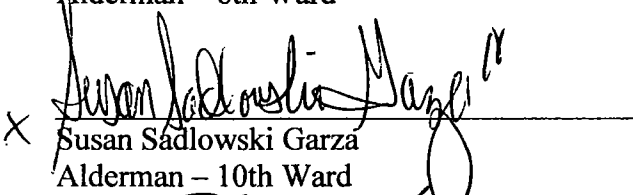

Leslie Hairston
Alderman - 5th Ward

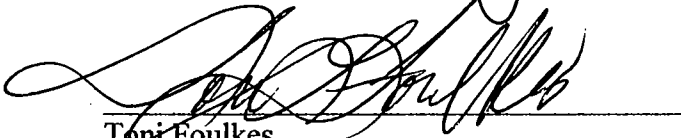
Roderick Sawyer
Alderman - 6th Ward

x 
Susan Sadlowski Garza
Alderman - 10th Ward

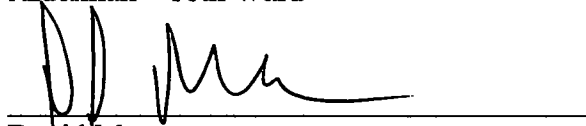
Toni Foulkes
Alderman - 16th Ward

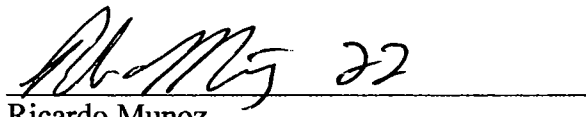
David Moore
Alderman - 17th Ward

Ricardo Munoz
Alderman - 22nd Ward

Chris Taliaferro
Alderman - 29th Ward

Scott Waguespack
Alderman – 32nd Ward

Carlos Ramirez-Rosa - 35

Carlos Ramirez-Rosa
Alderman – 35th Ward

Nicholas Sposato
Alderman – 38th Ward

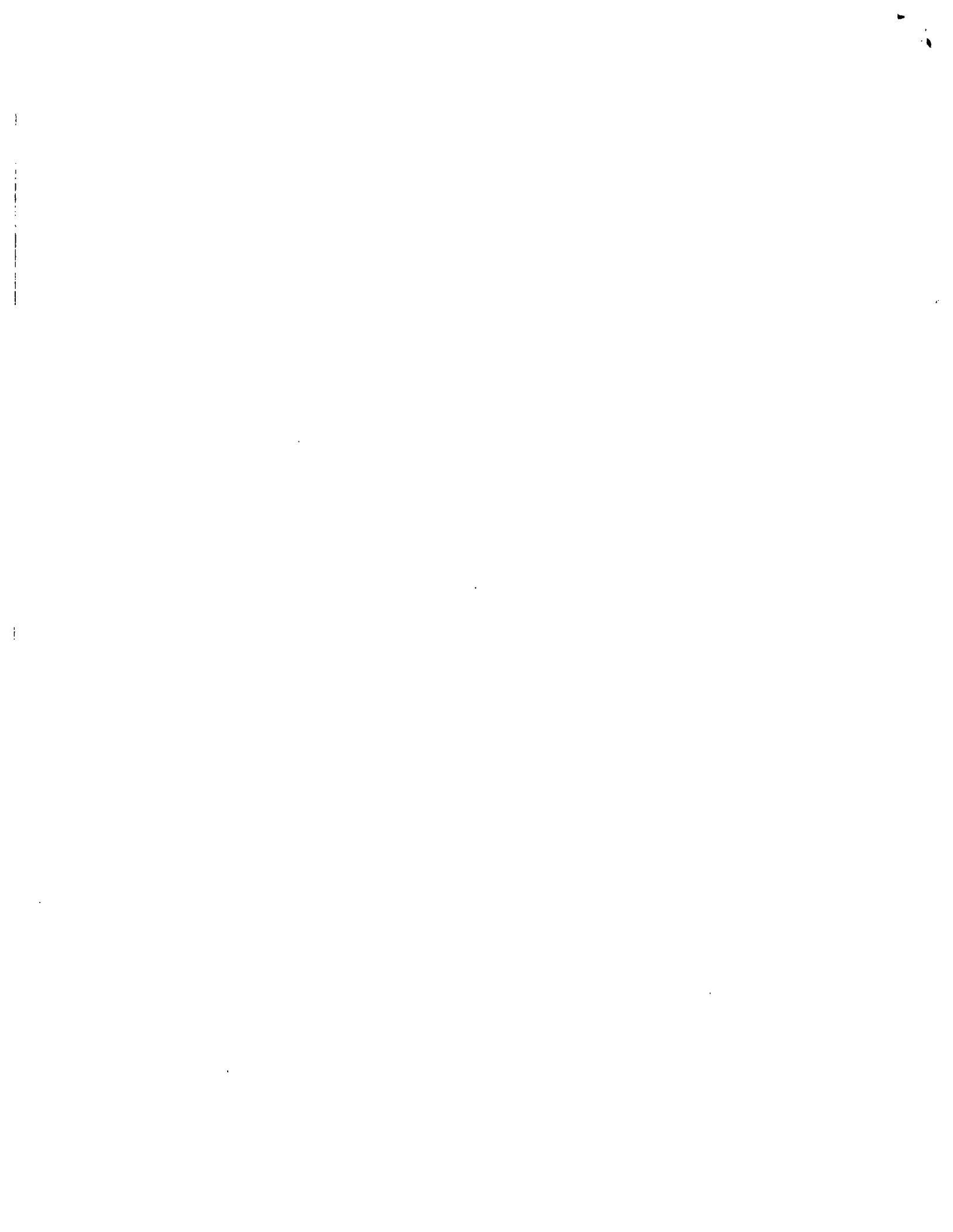

SECTION 2. This ordinance shall be in force and effect upon passage and approval.



John Arena
Alderman – 45th Ward

Leslie Hairston
Alderman – 5th Ward

Roderick Sawyer
Alderman – 6th Ward

Susan Sadlowski Garza
Alderman – 10th Ward

Toni Foulkes
Alderman – 16th Ward

David Moore
Alderman – 17th Ward

Ricardo Munoz
Alderman – 22nd Ward

Chris Taliaferro
Alderman – 29th Ward

Scott Waguespack
Alderman – 32nd Ward

Carlos Ramirez-Rosa
Alderman – 35th Ward

Nicholas Sposato
Alderman – 38th Ward

Robert Maldonado
Alderman - 26 Ward



City of Chicago

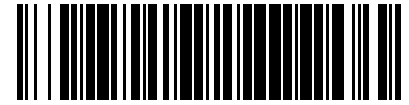

O2015-7777

Office of the City Clerk

Document Tracking Sheet

Meeting Date: 10/21/2015

Sponsor(s): Arena (45)
Hairston (5)
Sawyer (6)
Sadlowski Garza (10)
Foulkes (16)
Moore (17)
Munoz (22)
Waguespack (32)
Ramirez-Rosa (35)
Maldonado (26)

Type: Ordinance

Title: Amendment of Municipal Code Section 4-156-020
concerning imposition of amusement tax for horse drawn
carriages

Committee(s) Assignment: Committee on Finance

ORDINANCE

BE IT ORDAINED BY THE CITY COUNCIL OF THE CITY OF CHICAGO:

SECTION 1. Section 4-156-020 of the Municipal Code of Chicago is hereby amended by deleting the struck-through language and inserting the underscored language as follows:

4-156-020 Tax imposed

A. Except as otherwise provided by this article, an amusement tax is imposed upon the patrons of every amusement within the city. The rate of the tax shall be equal to nine percent of the admission fees or other charges paid for the privilege to enter, to witness, to view or to participate in such amusement, unless subsection E of this section provides for a lower rate.

B. The tax imposed by subsection A shall not apply to the following persons or privileges:

(omitted text is unaffected by this ordinance)

(3) ~~the privilege of hiring a horse drawn carriage licensed under chapter 9-108 of this Code or a pedicab licensed under chapter 9-110 of this code, or~~

SECTION 2. This ordinance shall be in force and effect upon passage and approval.

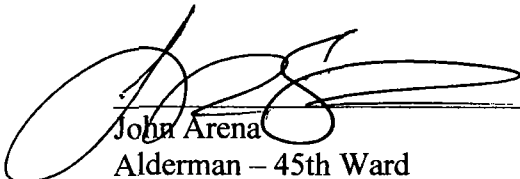

John Arena
Alderman – 45th Ward

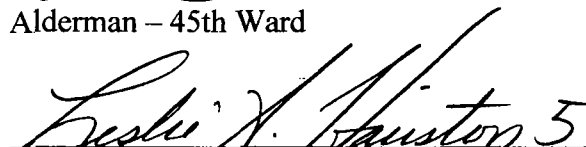

Leslie Hairston
Alderman – 5th Ward



Roderick Sawyer
Alderman – 6th Ward

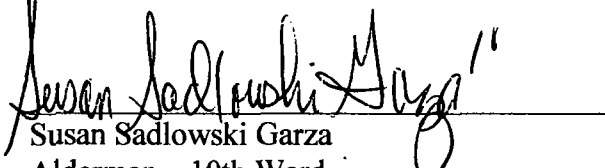

Susan Sadlowski Garza
Alderman – 10th Ward

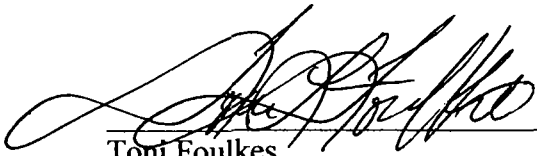

Toni Foulkes
Alderman - 16th Ward

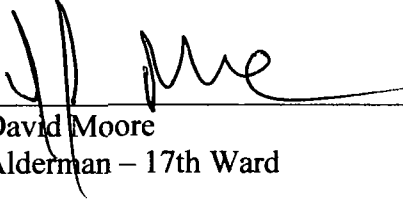

David Moore
Alderman - 17th Ward

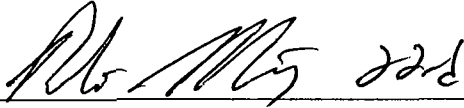

Ricardo Munoz
Alderman - 22nd Ward

Chris Taliaferro
Alderman - 29th Ward

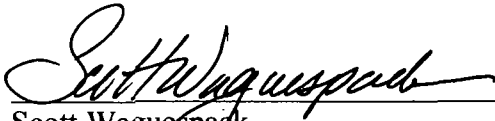

Scott Waguespack
Alderman - 32nd Ward

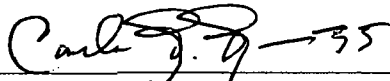

Carlos Ramirez-Rosa
Alderman - 35th Ward

Nicholas Sposato
Alderman - 38th Ward

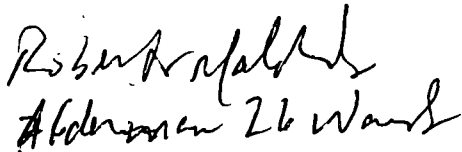

Robert Raphael
Alderman 26 Ward

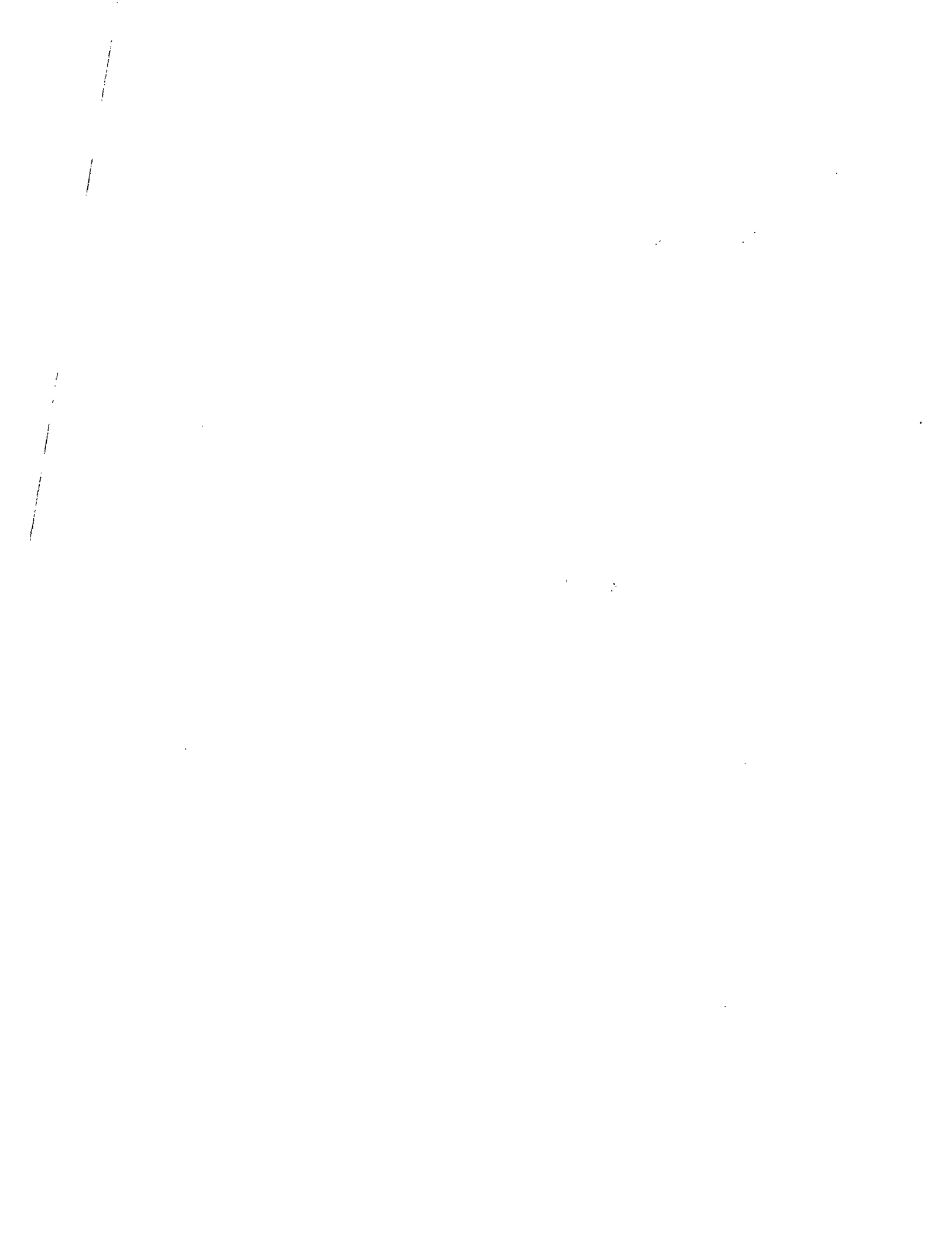



City of Chicago

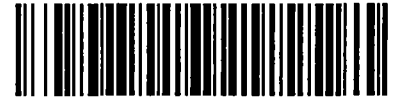

Or2015-644

Office of the City Clerk

Document Tracking Sheet

Meeting Date:	10/21/2015
Sponsor(s):	Moreno (1)
Type:	Order
Title:	Issuance of permits for sign(s)/signboard(s) at 1433 -- 1437 N Milwaukee Ave
Committee(s) Assignment:	Committee on Zoning, Landmarks and Building Standards

Committee on Zoning, Landmarks, and Building Standards

(Signs)

ORDERED, That the Commissioner of Buildings is hereby directed to issue a sign permit to: (Contractor's name and address)

Magic Sign

2839 West Montrose Avenue

Country Club Hills, Illinois 60618

for the erection of a sign/signboard over 24 feet in height and/or over 100 square feet (in area of one face) at: (Business Name & Address)

fringe

1433-37 North Milwaukee Avenue

Chicago, Illinois 60636

Dimensions: Length 50 feet **Height** 7 feet
Height above grade/roof to top of sign 10 feet
TOTAL SQUARE FOOT AREA: 350 square feet

Such sign(s) shall comply with all applicable provisions of TITLE 17 of the Chicago Zoning Ordinance and all other applicable provisions of the Municipal Code of the City of Chicago governing the construction and maintenance of outdoor signs, signboards and structures.

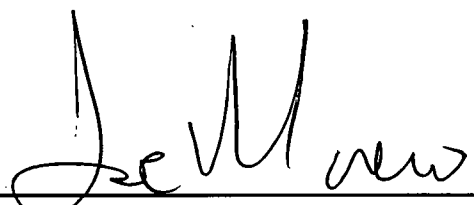

PROCO JOE MORENO
Alderman, 1st Ward

Zoning

COMMITTEE ON ZONING, LANDMARKS & BUILDING STANDARDS

(signs)

ORDERED, That the Commissioner of Buildings is hereby directed to issue a sign permit to:

Name of Sign Company **MAGIC SIGN**
Street Address **2839 W. Montrose Ave**
City State, Zip Code **CHICAGO IL 60618**

For the erection of a sign/signboard over 24 feet in height and/or 100 square feet (in area of one face) at:

Sign Location **1433-37**
Street Address **N. MILWAUKEE Ave**
City State, Zip Code **CHICAGO IL**

Dimensions: Length: # feet - # inches **50'** Height: # feet - # inches **7'**

Height above grade/roof to top of sign: # feet - # inches **10'**

TOTAL SQUARE FOOT AREA: # square feet **350 Sqft.**

Such sign(s) shall comply with all applicable provisions of TITLE 17 of the Chicago Zoning Ordinance and all other applicable provisions of the Municipal Code of the CITY OF CHICAGO governing the construction and maintenance of outdoor sign, signboards and structures.



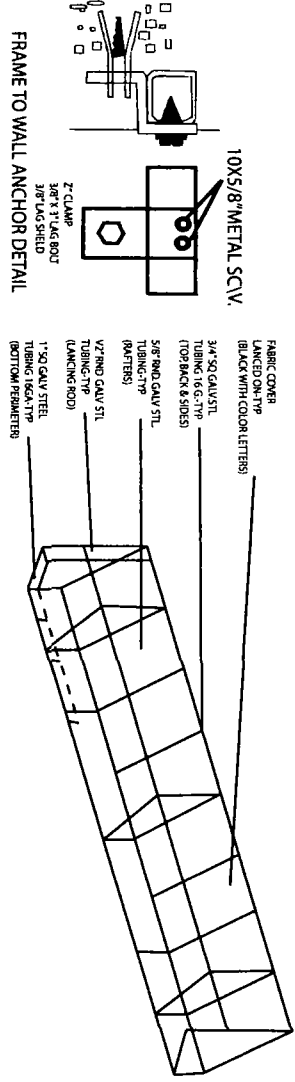
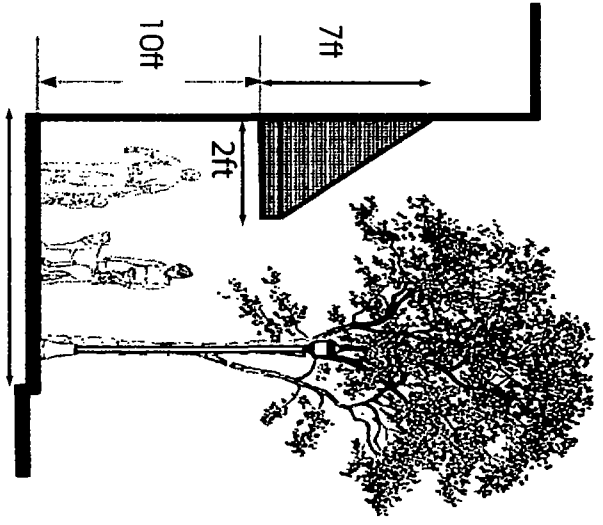
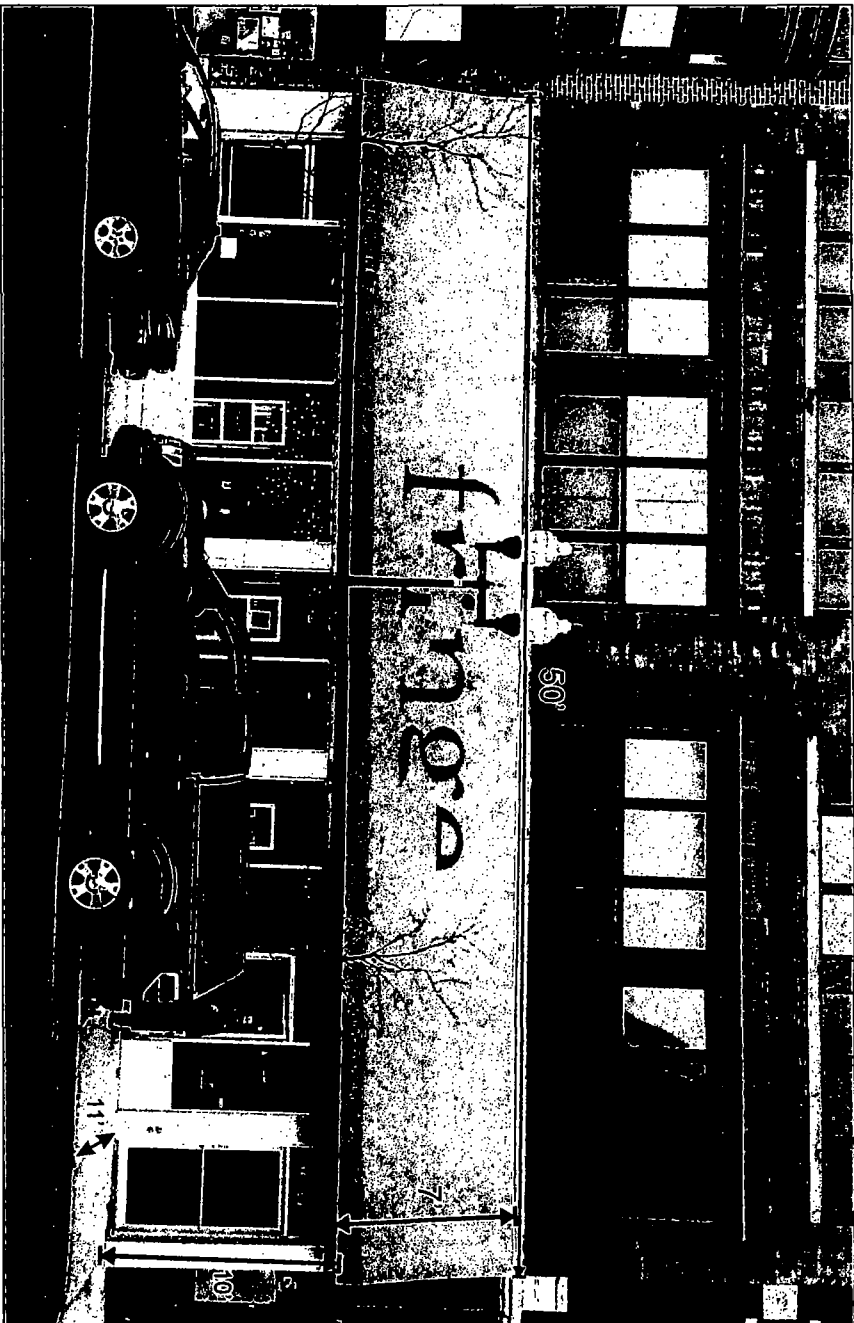

Customer Approval: _____

Date: _____

Client: Fringe

Drawing #: 1

Address: 1433 - 37 N Milwaukee Ave.

Date: 08/10/15

Scale:

Drawn By:

Rev Date:

All sign and concepts shown here are confidential and are the property of Magic Sign Co. They are not to be distributed, copied or otherwise used without our written permission.

COMPUTER GENERATED COLORS ARE NOT A TRUE MATCH TO ANY PMS, VINYL OR PAINT.
 Tel: 773 267 5744, magic@magic.com
Magic Sign
 The Sign That Shines

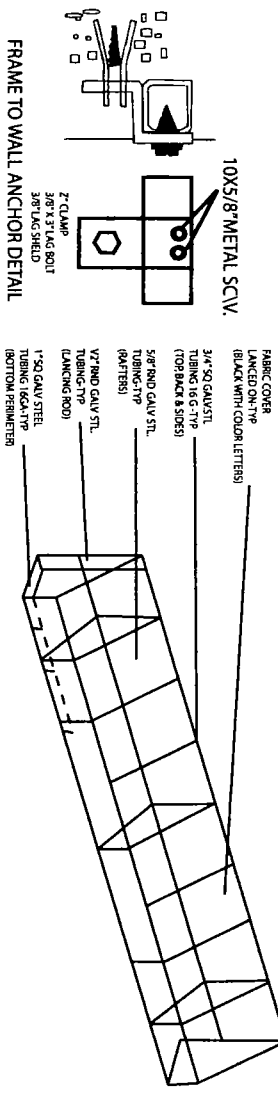
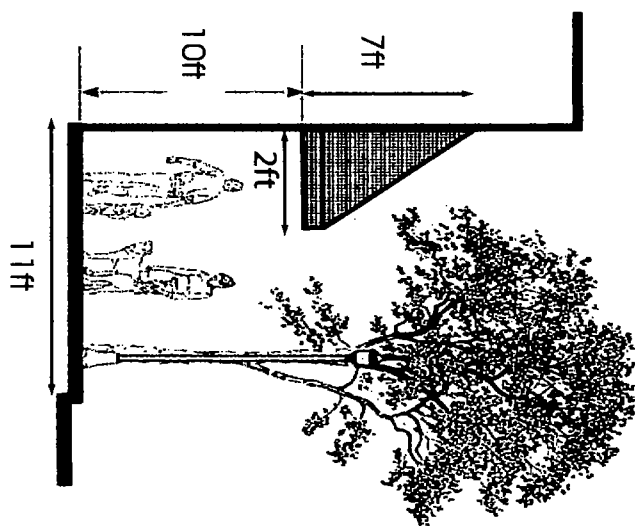
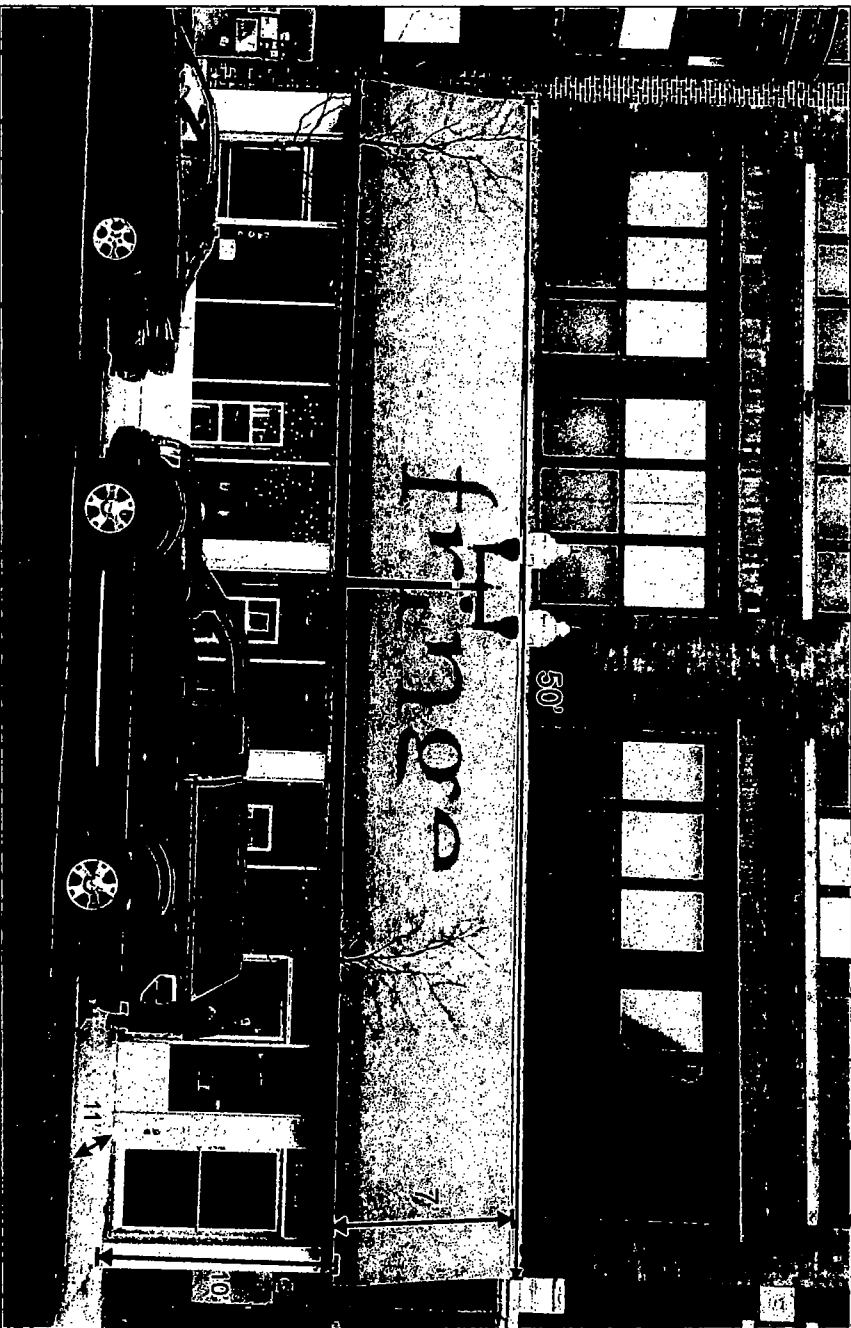

- FABRIC COVER
- LANCED OVAL TUBE
- (BLACK WITH COLOR LETTERS)
- 3/4" SQ GALV. STL. TUBING 16 G. TYP (TOP BACK & SIDES)
- 5/8" RND GALV. STL. TUBING 17 G. TYP (VERTICALS)
- 5/8" RND GALV. STL. TUBING 17 G. TYP (LANCING ROD)
- 1" SQ GALV. STEEL TUBING 160 G. TYP (BOTTOM PERIMETER)
- Z-CLAMP 3/8" X 3/16" BOLT 3/8" LAG SHELD

Customer Approval: _____

Date: _____

Client: Fringe

Drawing #: 1

Address: 1433 - 37 N Milwaukee Ave.

Date: 08/10/15

Scale:

Drawn By:

Rev Date:

All sign and concepts shown here are confidential and are the property of Magic Sign Co. They are not to be distributed, copied or otherwise used without our written permission.

COMPUTER GENERATED COLORS ARE NOT A TRUE MATCH TO ANY PMS, VINYL OR PAINT.
Tel: 773 267 5744, magicsign@stccglobal.net



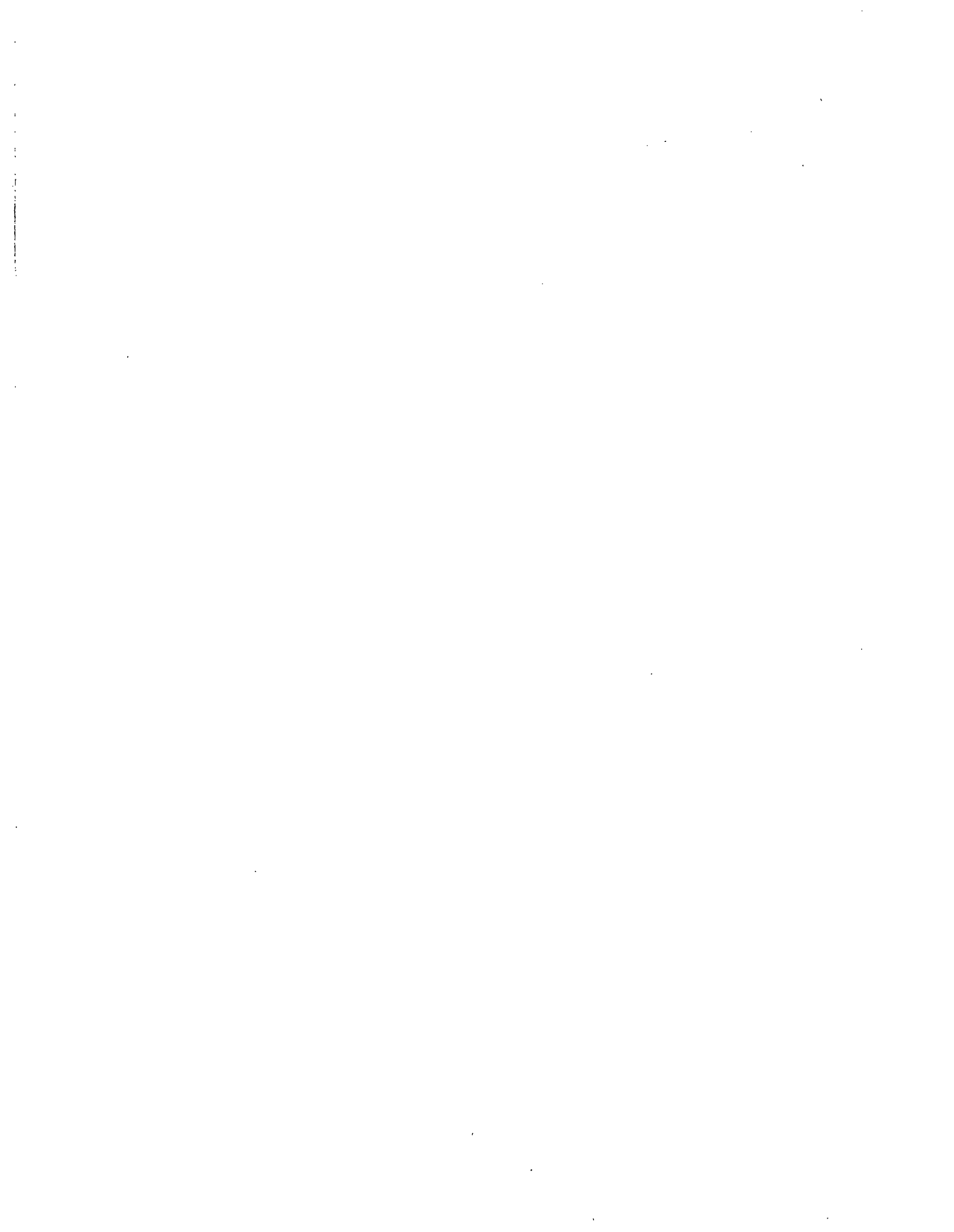



City of Chicago



Or2015-642

Office of the City Clerk

Document Tracking Sheet

Meeting Date:	10/21/2015
Sponsor(s):	O'Shea (19)
Type:	Order
Title:	Issuance of permits for sign(s)/signboard(s) at 9928 S Western Ave
Committee(s) Assignment:	Committee on Zoning, Landmarks and Building Standards

City Council
October 21, 2015

ORDERED, that the Commissioner of Buildings is hereby directed to issue a sign permit to:

Chesterfield Awning Co.
16999 Van Dam Road
South Holland, Illinois 606473

For the election of a sign/signboard over 100 square feet (in area of one face) at:

Chicagoland Eye Associates
9928 S. Western Avenue
Chicago, Illinois 60643

Dimensions:	Length 25' 0"	Height 8' 0"
Height above grade/roof to top of sign:	17' 0" to top of sign	
TOTAL SQUARE FOOT AREA:	200sq ft	

Such sign(s) shall comply with all applicable provision of TITLE 17 of the Chicago Zoning Ordinance and all other applicable provisions of the Municipal Code of the City of Chicago governing the construction and maintenance of outdoor signs, signboard and structures.

Alderman Matthew J. O'Shea
19th Ward



City of Chicago



Or2015-643

Office of the City Clerk

Document Tracking Sheet

Meeting Date:	10/21/2015
Sponsor(s):	Solis (25)
Type:	Order
Title:	Issuance of permits for sign(s)/signboard(s) at 2335 S Western Ave
Committee(s) Assignment:	Committee on Zoning, Landmarks and Building Standards

October 21, 2015

Committee on Zoning, Landmarks, and Building Standards

(Signs)

ORDERED, That the Commissioner of Buildings is hereby directed to issue a sign permit to: (Contractor's name and address)

Dsigns MX Corp.

3801 W 63rd St

Chicago, Illinois 60608

for the erection of a sign/signboard over 24 feet in height and/or over 100 square feet (in area of one face) at: (Business Name & Address)

Mufflers 4less

2335 S Western Avenue

Chicago, Illinois 60608

Dimensions: Length 106 ft **Height** 5'8"
Height above grade/roof to top of sign 9 feet
TOTAL SQUARE FOOT AREA: 601 square feet

Such sign(s) shall comply with all applicable provisions of TITLE 17 of the Chicago Zoning Ordinance and all other applicable provisions of the Municipal Code of the City of Chicago governing the construction and maintenance of outdoor signs, signboards and structures.

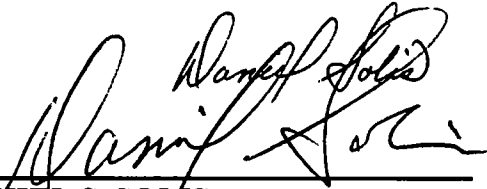

DANIEL S. SOLIS
Alderman, 25th Ward



City of Chicago



Or2015-647

Office of the City Clerk

Document Tracking Sheet

Meeting Date:	10/21/2015
Sponsor(s):	Mell (33)
Type:	Order
Title:	Issuance of permits for sign(s)/signboard(s) at 4710 N Kimball Ave
Committee(s) Assignment:	Committee on Zoning, Landmarks and Building Standards

ORDERED, That the Commissioner of the Building Department is hereby directed to issue a sign permit to: *(Contractor's name and address)*

**OMEGA SIGN AND LIGHTING
100 W FAY
ADDISON, IL 60101**

For the erection of a sign / signboard over twenty-four (24) feet in height and / or over one hundred (100) square feet (in area of one face) at:

**SHOPS ON KIMBALL
4710 N KIMBALL
CHICAGO, IL 60625**

With the following Dimensions, height, and square foot area:

Dimensions: **Length: 8' – 6" feet Height 21' – 7" feet**
Height Above Grade / Roof to top of Sign: **4' feet**
Total Square Foot Area: **195.22 Square Feet**

Such signs shall comply with all provisions of Title 17 of the Chicago Zoning Ordinance and all other applicable provisions of the Municipal Code of the City of Chicago governing the construction and maintenance of outdoor signs, sign boards, and structures.

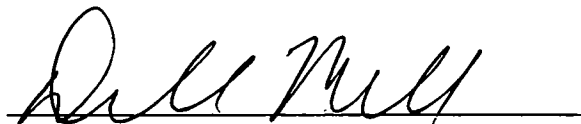
A handwritten signature in cursive script, appearing to read "Dale Miller", is written over a horizontal line.

Alderman, 33RD Ward

APPLICATION TO USE THE PUBLIC RIGHT OF WAY



APPLICANT INFORMATION

LEGAL NAME OF ENTITY: North Kimball JR TELLLZ
PERMIT MAILING ADDRESS: 8711-B West 95th Street
CITY: Hickory Hills STATE: IL ZIP CODE: 60457
CONTACT PERSON: Bill Klauseger TITLE: Manager
PHONE: 708-430-3150 FAX: 708-430-0531 E-MAIL: B.Klauseger@AOL.com

USE OF THE PUBLIC WAY

- List the proposed or existing use below and complete the worksheet on page 3.
Use only one application per public way use type.

TYPE	HOW MANY?	BUILDING ADDRESS
<u>TERRACE Pylon</u>	<u>1</u>	<u>4710 N. KIMBALL</u>

- Please enclose one sketch of proposed use of the public way, which maps to scale the proposed use and its relationship to surrounding right-of-way. All measurements must be indicated.

The prints should also accurately depict the location of the property line and public facilities (meters, light poles, sidewalks).

APPLICANT CERTIFICATION

I hereby certify that all statements made as part of the application, and the attachments herein, are true to the best of my knowledge and belief.

BY: William Klauseger TITLE: Manager

F.E.I.N. or SOCIAL SECURITY NUMBER: _____

ALDERMAN'S APPROVAL

As part of this application process, you are required to notify/obtain approval from the Alderman in whose ward your proposed use of the public way is located.

ALDERMAN'S SIGNATURE: [Signature] WARD: 33 DATE: 10/15/15



City of Chicago | Department of Business Affairs and Consumer Protection | Public Way Use Unit
Business Assistance Center | City Hall, Room 800 | 121 North LaSalle Street | Chicago, Illinois 60602
www.cityofchicago.org/bacp | 312.74.GOBIZ (744.6249) | 312.742.1974 (TTY)



NEW D/F MULTI-TENANT PYLON SIGN - SHOPS ON KIMBALL - 4710 N. KIMBALL AVE. CHICAGO, IL



EXISTING



PROPOSED

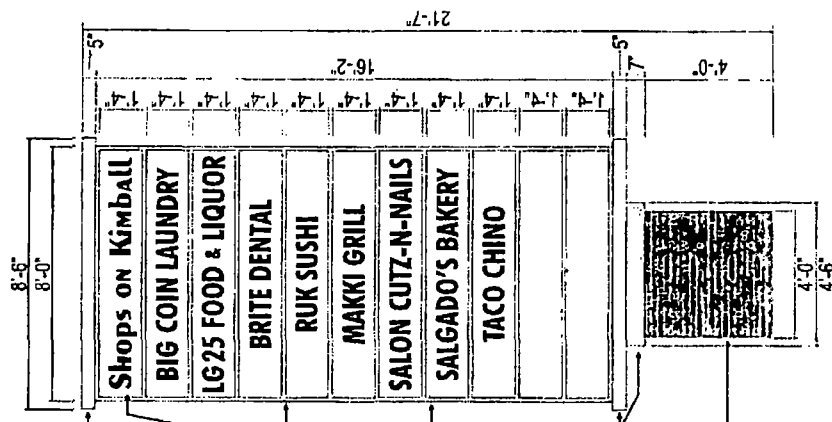
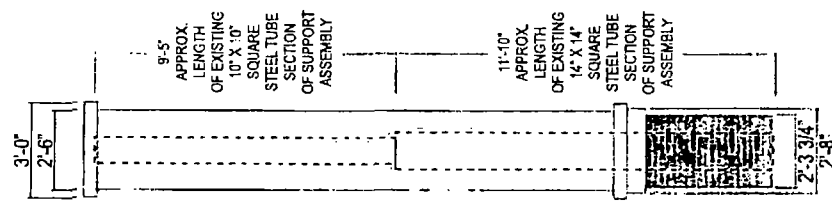

- DECORATIVE ALUMINUM LEDGE PAINTED MATTHEWS #MP25833 BONE WHITE
- MAIN I.D. SECTION: ROUTED ALUMINUM PANEL PAINTED MATTHEWS #MP25833 BONE WHITE WITH #2283 RED ACRYLIC BACK-UP.
- MULTI-TENANT SECTION: ALUMINUM CABINET WITH ALUMINUM RETAINERS AND DIVIDER BARS. ALL PAINTED MATTHEWS #MP25833 BONE WHITE. TRANSLUCENT WHITE POLYCARBONATE FACES WITH FIRST SURFACE APPLIED TRANSLUCENT BLACK VINYL GRAPHICS.
- ILLUMINATION: INTERNALLY ILLUMINATED USING WHITE NEPTUN SELF BALASTED LED TUBES.
- DECORATIVE ALUMINUM LEDGES PAINTED MATTHEWS #MP25833 BONE WHITE
- ALUMINUM SIGN BASE (COLUMN COVER) WITH "HISTORIC OLD WORLD" FAUX BRICK PANELS

MULTI-TENANT PYLON SIGN TO BE INSTALLED ONTO EXISTING POLE SUPPORT AND FOUNDATION SUPPLIED BY OTHERS. HOOK UP TO EXISTING ELECTRICAL AT BASE OF POLE SUPPLIED BY OTHERS. ALL EXISTING SIGNS MUST BE REMOVED FROM SUPPORT POLES) BEFORE INSTALLATION OF NEW SIGN.



SHOPS ON KIMBALL
 ADDRESS: 4710 N. Kimball Ave.
 CITY/STATE: Chicago, IL
 ZIP: 60625
 WWW.OMEGASIGNCHICAGO.COM
 PHONE 630.237.4397 FAX 630.237.4398



SCALE: 3/16" = 1'-0"	Rev 1	00/00/00
DATE: 06/23/15	Rev 2	00/00/00
DWG: 001	Rev 3	00/00/00
FILE PATH: SourceClient Files\Shops on Kimball - Chicago IL - pylon sign.rvt	Rev 4	00/00/00
	Rev 5	00/00/00
	Rev 6	00/00/00
	Rev 7	00/00/00

CUSTOMER APPROVAL	DATE
LANDLORD APPROVAL	DATE

ELECTRICAL NOTES
 1. All wiring shall be in accordance with the National Electrical Code (NEC) and all applicable local codes.
 2. Each sign must have a minimum of 120V AC power.
 3. All wiring shall be done in accordance with the manufacturer's instructions.
 4. All wiring shall be done in accordance with the manufacturer's instructions.
 5. All wiring shall be done in accordance with the manufacturer's instructions.

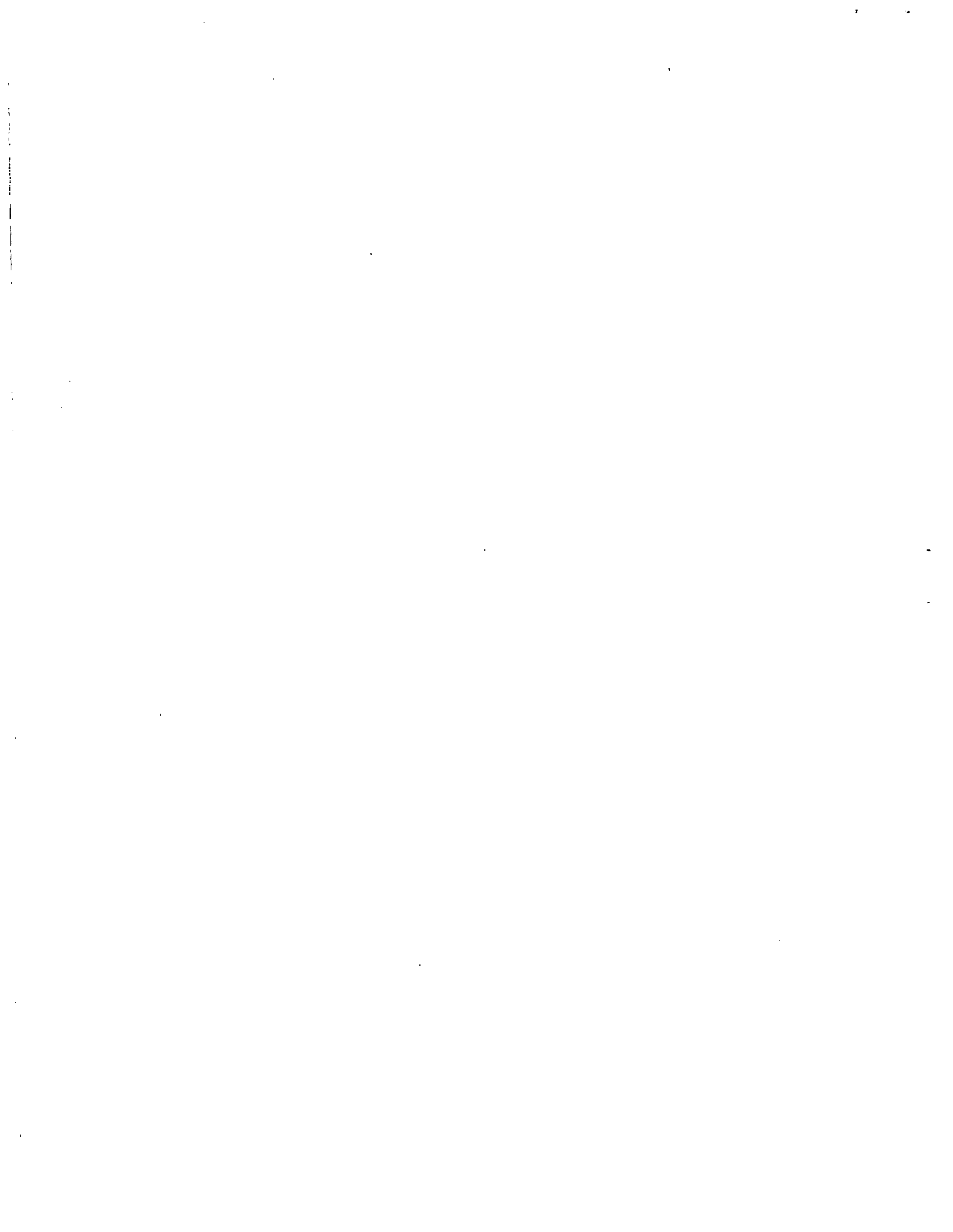



APPLICATION TO USE THE PUBLIC RIGHT OF WAY

APPLICATION WORKSHEET

- For use by NEW APPLICANTS ONLY.
- For renewals obtain form from City Hall, 121 N. LaSalle St., Rm. 800 or call (312) 74 - GOBIZ (744-6249)

Complete the worksheet for each use of the public way and indicate all applicable measurements.

	Exact Street (i.e. S. State St.)	Quantity	Length of structure along public way	Height of structure	Depth of structure	Height above grade	Total depth over public way	Is this sign(s) illuminated? (Y/N)	Is this an Existing Public Way Use (Y/N)
SIGNS	4710 N. KIMBALL	1	N/A	21-7'	3'	4'	N/A	Y	N
CANOPIES/AWINGS									
LIGHTS									

See example of required plans beginning on the next page.

NOTE: Pursuant to section 2-154-030 of the Municipal Code of the City of Chicago the Corporation Counsel of the City of Chicago may require any such additional information from any applicant to achieve full disclosure relevant to the request for action by the City Council or other city agency. Pursuant to section 2-154-020 of the Municipal code of the City of Chicago any material change in the information required above must be provided by supplementing this statement at any time up to the time the City Council or any city agency takes action on the application.

