



City of Chicago Office of the City Clerk

City Hall
121 North LaSalle Street
Room 107
Chicago, IL 60602
www.chicityclerk.com

Legislation Referred to Committees at the Chicago City Council Meeting 5/28/2014

Section 3c - Aldermanic Introductions Regarding Unclassified Matters

| File # | Title | Sponsor(s) | Committee Referral |
|--|------------|--|-------------------------------|
| 4-60-022 & 4-60-023 Disallow Alcoholic Liquor & Package Goods | | | |
| 1 | O2014-4205 | Amendment of Municipal Code Sections 4-60-022 and 4-60-023 to disallow additional alcoholic liquor and package good licenses on portions S Stony Island Ave, E 87th St and E 95th St | Harris (8) License |
| 4-60-022 Allow Alcoholic Liquor | | | |
| 2 | O2014-4235 | Amendment of Section 4-60-022 of Municipal Code to allow additional alcoholic liquor licenses on portion(s) of W Chicago Ave | Moreno (1) License |
| 4-60-023 Disallow Package Goods | | | |
| 3 | O2014-4206 | Amendment of Municipal Code Section 4-60-023 to disallow additional package goods licenses on portion(s) of N Mobile Ave | Graham (29) License |
| Alley Access Barrier(s) | | | |
| 4 | O2014-4236 | Exemption from physical barrier requirement for commercial driveway alley access for Ashland 820 LLC | Moreno (1) Transportation |
| 5 | O2014-4216 | Exemption from physical barrier requirement for commercial driveway alley access for CAF Construction LLC | Burns (4) Transportation |
| 6 | O2014-4218 | Exemption from physical barrier requirement for commercial driveway alley access for Dedicated Auto | Sawyer (6) Transportation |
| 7 | O2014-4209 | Exemption from physical barrier requirement for commercial driveway alley access for Little Feathers Performing Arts Child Care Center | Beale (9) Transportation |
| 8 | O2014-4245 | Exemption from physical barrier requirement for commercial driveway alley access for T.F. Real Estate (Commercial fast food Restaurant) | Pope (10) Transportation |
| 9 | O2014-4246 | Exemption from physical barrier requirement for commercial driveway alley access for Jump Start Academy-Amazing Friends LLC | Pope (10) Transportation |
| 10 | O2014-4210 | Exemption from physical barrier requirement for commercial driveway alley access for Jackie Edwards | Thomas (17) Transportation |
| 11 | O2014-4204 | Exemption from physical barrier requirement for commercial driveway alley access for Young Scholars Learning Center | Lane (18) Transportation |

Legislation Referred to Committees at the Chicago City Council Meeting

5/28/2014

Section 3c - Aldermanic Introductions Regarding Unclassified Matters

| File # | Title | Sponsor(s) | Committee Referral | |
|------------------|------------|---|--------------------|----------------|
| 12 | O2014-4207 | Exemption from physical barrier requirement for commercial driveway alley access for Rogelio Richart of Xpress Auto and Tires | Zalewski (23) | Transportation |
| 13 | O2014-4219 | Exemption from physical barrier requirement for commercial driveway alley access for J&M Auto Repair | Solis (25) | Transportation |
| 14 | O2014-4222 | Exemption from physical barrier requirement for commercial driveway alley access for Atotonilco | Solis (25) | Transportation |
| 15 | O2014-4241 | Exemption from physical barrier requirement for commercial driveway alley access for Phil Denny Peppercorn 1229 LLC | Burnett (27) | Transportation |
| 16 | O2014-4243 | Exemption from physical barrier requirement for commercial driveway alley access for Penelope Vamava Learn Chartered School Network | Burnett (27) | Transportation |
| 17 | O2014-4155 | Exemption from physical barrier requirement for commercial driveway alley access for Yakov Plotkim | Reboyras (30) | Transportation |
| 18 | O2014-4228 | Exemption from physical barrier requirement for commercial driveway alley access for Clybourn Construction LLC | Waguespack (32) | Transportation |
| 19 | O2014-4229 | Exemption from physical barrier requirement for commercial driveway alley access for Clybourn Ventures LLC | Waguespack (32) | Transportation |
| 20 | O2014-4213 | Exemption from physical barrier requirement for commercial driveway alley access for Dando Repair Resale and Restoration | Sposato (36) | Transportation |
| 21 | O2014-4239 | Exemption from physical barrier requirement for commercial driveway alley access for Wells Street Development LLC | Reilly (42) | Transportation |
| 22 | O2014-4240 | Exemption from physical barrier requirement for commercial driveway alley access for Eleven Hundred LLC | Reilly (42) | Transportation |
| 23 | O2014-4242 | Exemption from physical barrier requirement for commercial driveway alley access for 1221 N LaSalle LLC | Reilly (42) | Transportation |
| 24 | O2014-4238 | Exemption from physical barrier requirement for commercial driveway alley access for Chicago Cubs Baseball Club LLC | Tunney (44) | Transportation |
| 25 | O2014-4244 | Exemption from physical barrier requirement for commercial driveway alley access for Maya Motors, Inc. | Pawar (47) | Transportation |
| Awning(s) | | | | |
| 26 | O2014-4282 | Awning(s) for Artemio's Bakery No. 2 | Moreno (1) | Transportation |
| 27 | O2014-4288 | Awning(s) for Delta Animal Hospital | Moreno (1) | Transportation |
| 28 | O2014-4290 | Awning(s) for Gardner School, The | Moreno (1) | Transportation |
| 29 | O2014-4293 | Awning(s) for Janik's Cafe | Moreno (1) | Transportation |
| 30 | O2014-4300 | Awning(s) for Kasia's | Moreno (1) | Transportation |

Legislation Referred to Committees at the Chicago City Council Meeting

5/28/2014

Section 3c - Aldermanic Introductions Regarding Unclassified Matters

| File # | Title | Sponsor(s) | Committee Referral | |
|--------|------------|---|--------------------|----------------|
| 31 | O2014-4307 | Awning(s) for Margie's Candies | Moreno (1) | Transportation |
| 32 | O2014-4311 | Awning(s) for Milk & Honey Cafe | Moreno (1) | Transportation |
| 33 | O2014-4324 | Awning(s) for Mirai Sushi | Moreno (1) | Transportation |
| 34 | O2014-4325 | Awning(s) for Runa Japanese | Moreno (1) | Transportation |
| 35 | O2014-4329 | Awning(s) for Lou Malnati's Pizzeria | Fioretti (2) | Transportation |
| 36 | O2014-4334 | Awning(s) for Standing Room Only Chicago | Fioretti (2) | Transportation |
| 37 | O2014-4337 | Awning(s) for 7-Eleven | Fioretti (2) | Transportation |
| 38 | O2014-4342 | Awning(s) for Quick Snacks, Inc. | Hairston (5) | Transportation |
| 39 | O2014-4343 | Awning(s) for Subway | Hairston (5) | Transportation |
| 40 | O2014-4346 | Awning(s) for Vogue Cleaners | Hairston (5) | Transportation |
| 41 | O2014-4350 | Awning(s) for Chatham Jewelry & Loan, Inc. | Sawyer (6) | Transportation |
| 42 | O2014-4353 | Awning(s) for Sapstein Drugs | Sawyer (6) | Transportation |
| 43 | O2014-4360 | Awning(s) for Links to Learning Child Care | Harris (8) | Transportation |
| 44 | O2014-4363 | Awning(s) for Woodard Building, Inc. | Harris (8) | Transportation |
| 45 | O2014-4366 | Awning(s) for Ramon Reyes | Pope (10) | Transportation |
| 46 | O2014-4370 | Awning(s) for Archer Cafe | Balcer (11) | Transportation |
| 47 | O2014-4378 | Awning(s) for Village Discount Outlet, Inc. | Cardenas (12) | Transportation |
| 48 | O2014-4384 | Awning(s) for Doctor's Office | Burke (14) | Transportation |
| 49 | O2014-4392 | Awning(s) for Marin Funeral Home | Burke (14) | Transportation |
| 50 | O2014-4399 | Awning(s) for Tina's Cocktail Lounge | Thomas (17) | Transportation |
| 51 | O2014-4406 | Awning(s) for Djenne Collection | O'Shea (19) | Transportation |
| 52 | O2014-4408 | Awning(s) for Ellie's | O'Shea (19) | Transportation |
| 53 | O2014-4418 | Awning(s) for HTP Associates Occupation Ltd. | O'Shea (19) | Transportation |
| 54 | O2014-4421 | Awning(s) for Shear Soul, Inc. | O'Shea (19) | Transportation |
| 55 | O2014-4431 | Awning(s) for Cellular Zone | Chandler (24) | Transportation |
| 56 | O2014-4435 | Awning(s) for House of Fortune | Solis (25) | Transportation |
| 57 | O2014-4439 | Awning(s) for Grandma J's, Inc. | Maldonado (26) | Transportation |
| 58 | O2014-4444 | Awning(s) for Rob West Plumbing, Inc. | Maldonado (26) | Transportation |
| 59 | O2014-4448 | Awning(s) for Chasing Tails 4 U Pet Fitness, Inc. | Burnett (27) | Transportation |
| 60 | O2014-4451 | Awning(s) for Suite Lounge | Burnett (27) | Transportation |
| 61 | O2014-4458 | Awning(s) for Armitage Hair Salon | Reboyras (30) | Transportation |
| 62 | O2014-4462 | Awning(s) for Barbara Deerfler | Suarez (31) | Transportation |
| 63 | O2014-4473 | Awning(s) for V&J America Multiservices | Suarez (31) | Transportation |
| 64 | O2014-4479 | Awning(s) for BFF Bikes | Waguespack (32) | Transportation |

Legislation Referred to Committees at the Chicago City Council Meeting

5/28/2014

Section 3c - Aldermanic Introductions Regarding Unclassified Matters

| File # | Title | Sponsor(s) | Committee Referral | |
|--------|------------|---|--------------------|----------------|
| 65 | O2014-4482 | Awning(s) for New Divine Nails and Spa | Waguespack (32) | Transportation |
| 66 | O2014-4491 | Awning(s) for Peek, Aren't You Curious, Inc. | Waguespack (32) | Transportation |
| 67 | O2014-4498 | Awning(s) for 24 Karrots | Waguespack (32) | Transportation |
| 68 | O2014-4512 | Awning(s) for Beauty Box Hair Salon & Spa | Colón (35) | Transportation |
| 69 | O2014-4515 | Awning(s) for Carniceria La Mejor, Inc. | Colón (35) | Transportation |
| 70 | O2014-4519 | Awning(s) for Chuck's & Ed's Tavern | Colón (35) | Transportation |
| 71 | O2014-4526 | Awning(s) for Restaurant 2 Amigos | Colón (35) | Transportation |
| 72 | O2014-4539 | Awning(s) for Pierre's Mini Detail Center | Laurino (39) | Transportation |
| 73 | O2014-4548 | Awning(s) for Piatto Pronto | O'Connor (40) | Transportation |
| 74 | O2014-4552 | Awning(s) for Subway | O'Connor (40) | Transportation |
| 75 | O2014-4561 | Awning(s) for Ernest Cheirgalos | O'Connor (41) | Transportation |
| 76 | O2014-4565 | Awning(s) for Le Flour Bake Shop & Market, Inc. | O'Connor (41) | Transportation |
| 77 | O2014-4566 | Awning(s) for Argo Tea | Reilly (42) | Transportation |
| 78 | O2014-4573 | Awning(s) for Bedazzled Nails & Spa, Inc. | Reilly (42) | Transportation |
| 79 | O2014-4576 | Awning(s) for Hangge-Uppe, Inc., The | Reilly (42) | Transportation |
| 80 | O2014-4580 | Awning(s) for Hotel Allegro | Reilly (42) | Transportation |
| 81 | O2014-4589 | Awning(s) for Luxbar | Reilly (42) | Transportation |
| 82 | O2014-4596 | Awning(s) for Maggiano's Little Italy - privilege No. 1112890 | Reilly (42) | Transportation |
| 83 | O2014-4600 | Awning(s) for Maggiano's Little Italy - privilege No. 1112891 | Reilly (42) | Transportation |
| 84 | O2014-4605 | Awning(s) for North Community Bank | Reilly (42) | Transportation |
| 85 | O2014-4611 | Awning(s) for Rossi's Liquors, Inc. | Reilly (42) | Transportation |
| 86 | O2014-4613 | Awning(s) for Trattoria Gianni | Smith (43) | Transportation |
| 87 | O2014-4619 | Awning(s) for Artemio's Bakery | Tunney (44) | Transportation |
| 88 | O2014-4630 | Awning(s) for Ballet D'Enfant | Tunney (44) | Transportation |
| 89 | O2014-4636 | Awning(s) for Carissima, Inc. | Tunney (44) | Transportation |
| 90 | O2014-4638 | Awning(s) for Cohiba Cuban Cuisine, Inc. | Tunney (44) | Transportation |
| 91 | O2014-4645 | Awning(s) for Exedus II | Tunney (44) | Transportation |
| 92 | O2014-4647 | Awning(s) for K.S. Cleaners and Laundromat | Tunney (44) | Transportation |
| 93 | O2014-4648 | Awning(s) for McKillip Animal Hospitals | Tunney (44) | Transportation |
| 94 | O2014-4650 | Awning(s) for Murphy's Bleachers | Tunney (44) | Transportation |
| 95 | O2014-4651 | Awning(s) for New Cleaners | Tunney (44) | Transportation |
| 96 | O2014-4654 | Awning(s) for Plus Auto Care | Tunney (44) | Transportation |
| 97 | O2014-4659 | Awning(s) for Shirts Illustrated, Inc. | Tunney (44) | Transportation |

Legislation Referred to Committees at the Chicago City Council Meeting

5/28/2014

Section 3c - Aldermanic Introductions Regarding Unclassified Matters

| File # | Title | Sponsor(s) | Committee Referral | |
|------------------|------------|---|--------------------|----------------|
| 98 | O2014-4661 | Awning(s) for Sushi Mura Japanese Restaurant | Tunney (44) | Transportation |
| 99 | O2014-4663 | Awning(s) for 7-Eleven | Tunney (44) | Transportation |
| 100 | O2014-4666 | Awning(s) for House of Hair, Inc. | Arena (45) | Transportation |
| 101 | O2014-4668 | Awning(s) for La Pena Restaurante | Arena (45) | Transportation |
| 102 | O2014-4674 | Awning(s) for Fifth Third Bank | Cappleman (46) | Transportation |
| 103 | O2014-4677 | Awning(s) for Eye See Ravenswood, P.C. | Pawar (47) | Transportation |
| 104 | O2014-4680 | Awning(s) for New Asia Restaurant | Pawar (47) | Transportation |
| 105 | O2014-4706 | Awning(s) for Northcenter Rug Cleaning | Pawar (47) | Transportation |
| 106 | O2014-4709 | Awning(s) for Ricochets | Pawar (47) | Transportation |
| 107 | O2014-4712 | Awning(s) for Thai Oscar | Pawar (47) | Transportation |
| 108 | O2014-4714 | Awning(s) for Winona Cleaners, Inc. | Pawar (47) | Transportation |
| 109 | O2014-4717 | Awning(s) for Know No Limits | Osterman (48) | Transportation |
| 110 | O2014-4721 | Awning(s) for Vincent | Osterman (48) | Transportation |
| 111 | O2014-4535 | Awning(s) for Grooming by Galdy | Moore (49) | Transportation |
| 112 | O2014-4722 | Awning(s) for Par Birdie Foods | Silverstein (50) | Transportation |
| Canopy(s) | | | | |
| 113 | O2014-4524 | Canopy(s) for Fringe A Hair Salon, Inc. | Moreno (1) | Transportation |
| 114 | O2014-4527 | Canopy(s) for Lubinski Furniture Sale | Moreno (1) | Transportation |
| 115 | O2014-4529 | Canopy(s) for Wabash/Roosevelt LLC | Fioretti (2) | Transportation |
| 116 | O2014-4531 | Canopy(s) for 233 S Wacker LLC | Fioretti (2) | Transportation |
| 117 | O2014-4536 | Canopy(s) for Lakeside Bank | Dowell (3) | Transportation |
| 118 | O2014-4540 | Canopy(s) for Big City Fashions | Sawyer (6) | Transportation |
| 119 | O2014-4557 | Canopy(s) for Catholic Charities of Chicago, The | Pope (10) | Transportation |
| 120 | O2014-4567 | Canopy(s) for Cortez Carter - 7901-7911 S Racine Ave | Thomas (17) | Transportation |
| 121 | O2014-4572 | Canopy(s) for Cortez Carter - 1151-1159 W 79th St | Thomas (17) | Transportation |
| 122 | O2014-4574 | Canopy(s) for Las Vegas Nite Club, Inc. | Maldonado (26) | Transportation |
| 123 | O2014-4579 | Canopy(s) for Greek Islands Restaurant | Burnett (27) | Transportation |
| 124 | O2014-4582 | Canopy(s) for El Vigia Restaurant | Colón (35) | Transportation |
| 125 | O2014-4584 | Canopy(s) for Allied Inventory Co., Inc. | O'Connor (40) | Transportation |
| 126 | O2014-4592 | Canopy(s) for Hyatt Place | Reilly (42) | Transportation |
| 127 | O2014-4597 | Canopy(s) for James Hotel Chicago | Reilly (42) | Transportation |
| 128 | O2014-4606 | Canopy(s) for Portillo's Hot Dogs, Inc. - Privilege No. 1112895 | Reilly (42) | Transportation |

Legislation Referred to Committees at the Chicago City Council Meeting

5/28/2014

Section 3c - Aldermanic Introductions Regarding Unclassified Matters

| File # | Title | Sponsor(s) | Committee Referral | |
|------------------------------------|------------|---|---|------------------------|
| 129 | O2014-4610 | Canopy(s) for Portillo's Hot Dogs, Inc. - Privilege No. 1113072 | Reilly (42) | Transportation |
| 130 | O2014-4614 | Canopy(s) for Reit Management & Research LLC | Reilly (42) | Transportation |
| 131 | O2014-4624 | Canopy(s) for 535 North Michigan Venture LLC | Reilly (42) | Transportation |
| 132 | O2014-4658 | Canopy(s) for Public Storage | Smith (43) | Transportation |
| 133 | O2014-4665 | Canopy(s) for Days Inn Chicago | Tunney (44) | Transportation |
| 134 | O2014-4667 | Canopy(s) for Ann Sather's Cafe | Tunney (44) | Transportation |
| 135 | O2014-4669 | Canopy(s) for O'Malley's Liquor Kitchen | Tunney (44) | Transportation |
| 136 | O2014-4670 | Canopy(s) for Salt & Pepper Diner | Tunney (44) | Transportation |
| 137 | O2014-4672 | Canopy(s) for Self Storage No. 1 | Tunney (44) | Transportation |
| 138 | O2014-4660 | Canopy(s) for Architectural Artifacts, Inc. | Pawar (47) | Transportation |
| 139 | O2014-4664 | Canopy(s) for Holsten Management Corp. | Osterman (48) | Transportation |
| Committee/Public Hearing(s) | | | | |
| 140 | R2014-356 | Call for hearing(s) to identify health care provider issues at Veterans Administration hospitals and facilities | Balcer (11) Reboyas (30) Cardenas (12) Burke (14) | Human Relations |
| 141 | R2014-352 | Call on Commissioner of Department of Business Affairs and representatives of Chicago Police Department and banking and retail industry to provide information on fraud prevention and identity security when making credit card transactions | Burke (14) Laurino (39) | Finance |
| 142 | R2014-351 | Call for hearing(s) on methods and programs used to educate children, young adults and adults about dangers of violent responses to conflict | Thompson (16) Burnett (27) Dowell (3) Lane (18) Austin (34) Pawar (47) Beale (9) Reboyas (30) Cochran (20) O'Shea (19) | Joint Education/Health |

Legislation Referred to Committees at the Chicago City Council Meeting

5/28/2014

Section 3c - Aldermanic Introductions Regarding Unclassified Matters

| File # | Title | Sponsor(s) | Committee Referral | |
|------------------------------|------------|--|--|----------------|
| 143 | R2014-358 | Chicago Board of Education, Community College District No. 508, Chicago Park District, Chicago Transit Authority, and Chicago Housing Authority urged to adopt diversity in non-minority owned firms disclosure requirements | Thomas (17) Austin (34) Burnett (27) Ervin (28) Graham (29) Mitts (37) Cochran (20) Chandler (24) Lane (18) Holmes (7) Brookins (21) Harris (8) Sawyer (6) Dowell (3) Beale (9) Foulkes (15) Thompson (16) | Finance |
| Grant(s) of Privilege | | | | |
| 144 | O2014-4278 | Grant(s) of privilege in public way for Artemio's Bakery No. 2 | Moreno (1) | Transportation |
| 145 | O2014-4284 | Grant(s) of privilege in public way for Ashland & Division Currency Exchange | Moreno (1) | Transportation |
| 146 | O2014-4287 | Grant(s) of privilege in public way for Bartosz Wisniewski | Moreno (1) | Transportation |
| 147 | O2014-4298 | Grant(s) of privilege in public way for Delta Animal Hospital | Moreno (1) | Transportation |
| 148 | O2014-4299 | Grant(s) of privilege in public way for Gold Star Bar, Inc. | Moreno (1) | Transportation |
| 149 | O2014-4301 | Grant(s) of privilege in public way for Hollywood Grill | Moreno (1) | Transportation |
| 150 | O2014-4309 | Grant(s) of privilege in public way for Mariano's No. 8527 Ukranian Village | Moreno (1) | Transportation |
| 151 | O2014-4310 | Grant(s) of privilege in public way for Pet Supplies Plus | Moreno (1) | Transportation |
| 152 | O2014-4314 | Grant(s) of privilege in public way for Picante's Authentaco | Moreno (1) | Transportation |
| 153 | O2014-4318 | Grant(s) of privilege in public way for Real Drugs, Inc. | Moreno (1) | Transportation |
| 154 | O2014-4321 | Grant(s) of privilege in public way for Reckless Records | Moreno (1) | Transportation |
| 155 | O2014-4327 | Grant(s) of privilege in public way for Reckless Records - light fixtures | Moreno (1) | Transportation |
| 156 | O2014-4330 | Grant(s) of privilege in public way for Roscoe Village Chamber of Commerce | Moreno (1) | Transportation |
| 157 | O2014-4354 | Grant(s) of privilege in public way for Argo Tea | Fioretti (2) | Transportation |
| 158 | O2014-4356 | Grant(s) of privilege in public way for Ashland & Van Buren | Fioretti (2) | Transportation |
| 159 | O2014-4361 | Grant(s) of privilege in public way for Brasserie by LM | Fioretti (2) | Transportation |

Legislation Referred to Committees at the Chicago City Council Meeting

5/28/2014

Section 3c - Aldermanic Introductions Regarding Unclassified Matters

| File # | Title | Sponsor(s) | Committee Referral |
|--------|--|--------------|--------------------|
| 160 | O2014-4364 Grant(s) of privilege in public way for Daily Parking, Inc. | Fioretti (2) | Transportation |
| 161 | O2014-4365 Grant(s) of privilege in public way for Jaks Tap | Fioretti (2) | Transportation |
| 162 | O2014-4373 Grant(s) of privilege in public way for Paramount Lofts Condo Assn. - balconies | Fioretti (2) | Transportation |
| 163 | O2014-4390 Grant(s) of privilege in public way for Paramount Lofts Condo Assn. - grease separator | Fioretti (2) | Transportation |
| 164 | O2014-4396 Grant(s) of privilege in public way for Petco | Fioretti (2) | Transportation |
| 165 | O2014-4404 Grant(s) of privilege in public way for St. Leonard's Ministries | Fioretti (2) | Transportation |
| 166 | O2014-4424 Grant(s) of privilege in public way for 36th and King Drive, Inc. Amoco | Fioretti (2) | Transportation |
| 167 | O2014-4433 Grant(s) of privilege in public way for 303 Madison - roof soffit | Fioretti (2) | Transportation |
| 168 | O2014-4436 Grant(s) of privilege in public way for 303 Madison - vaults | Fioretti (2) | Transportation |
| 169 | O2014-4447 Grant(s) of privilege in public way for 1720 S Michigan Condo - balconies | Fioretti (2) | Transportation |
| 170 | O2014-4483 Grant(s) of privilege in public way for 1720 S Michigan Condo - planters | Fioretti (2) | Transportation |
| 171 | O2014-4492 Grant(s) of privilege in public way for University of Chicago, The - caissons | Hairston (5) | Transportation |
| 172 | O2014-4513 Grant(s) of privilege in public way for University of Chicago, The - sheeting | Hairston (5) | Transportation |
| 173 | O2014-4516 Grant(s) of privilege in public way for University of Chicago Medical Center | Hairston (5) | Transportation |
| 174 | O2014-4533 Grant(s) of privilege in public way for CBA, Small Business Development, Inc. - 611 E 75th St | Sawyer (6) | Transportation |
| 175 | O2014-4543 Grant(s) of privilege in public way for CBA, Small Business Development, Inc. - 555 E 75th St | Sawyer (6) | Transportation |
| 176 | O2014-4545 Grant(s) of privilege in public way for CBA, Small Business Development, Inc. - 511 E 75th St | Sawyer (6) | Transportation |
| 177 | O2014-4551 Grant(s) of privilege in public way for CBA, Small Business Development, Inc. - 457 E 75th St | Sawyer (6) | Transportation |
| 178 | O2014-4558 Grant(s) of privilege in public way for CBA, Small Business Development, Inc. - 647 E 75th St | Sawyer (6) | Transportation |
| 179 | O2014-4560 Grant(s) of privilege in public way for City Sports on Michigan | Beale (9) | Transportation |
| 180 | O2014-4564 Grant(s) of privilege in public way for US Furniture & Linen | Beale (9) | Transportation |
| 181 | O2014-4569 Grant(s) of privilege in public way for DSO Properties LLC - bay windows | Balcer (11) | Transportation |

Legislation Referred to Committees at the Chicago City Council Meeting

5/28/2014

Section 3c - Aldermanic Introductions Regarding Unclassified Matters

| File # | Title | Sponsor(s) | Committee Referral | |
|--------|------------|--|--------------------|----------------|
| 182 | O2014-4585 | Grant(s) of privilege in public way for DSO Properties LLC - fire escape | Balcer (11) | Transportation |
| 183 | O2014-4590 | Grant(s) of privilege in public way for Jesus Estrella | Cardenas (12) | Transportation |
| 184 | O2014-4593 | Grant(s) of privilege in public way for American Family Insurance | Quinn (13) | Transportation |
| 185 | O2014-4598 | Grant(s) of privilege in public way for Athletic & Therapeutic Institute of Midway LLC | Quinn (13) | Transportation |
| 186 | O2014-4603 | Grant(s) of privilege in public way for Ray Buick, Inc. | Quinn (13) | Transportation |
| 187 | O2014-4616 | Grant(s) of privilege in public way for Taqueria La Haciendita, Inc. | Quinn (13) | Transportation |
| 188 | O2014-4620 | Grant(s) of privilege in public way for Apartment Lounge, The | Burke (14) | Transportation |
| 189 | O2014-4627 | Grant(s) of privilege in public way for PS Orangeco, Inc. No. 28401 | Burke (14) | Transportation |
| 190 | O2014-4649 | Grant(s) of privilege in public way for Zapotlan, Inc | Burke (14) | Transportation |
| 191 | O2014-4725 | Grant(s) of privilege in public way for Mexico Sons Muffler & Brakes | Thompson (16) | Transportation |
| 192 | O2014-4726 | Grant(s) of privilege in public way for State Farm | Thompson (16) | Transportation |
| 193 | O2014-4728 | Grant(s) of privilege in public way for Tibbs Superior Auto | Thompson (16) | Transportation |
| 194 | O2014-4729 | Grant(s) of privilege in public way for Charming Beauty | Thomas (17) | Transportation |
| 195 | O2014-4730 | Grant(s) of privilege in public way for City Mart | Thomas (17) | Transportation |
| 196 | O2014-4732 | Grant(s) of privilege in public way for King Food & Liquor | Thomas (17) | Transportation |
| 197 | O2014-4735 | Grant(s) of privilege in public way for Riverdale Body Shop | Thomas (17) | Transportation |
| 198 | O2014-4736 | Grant(s) of privilege in public way for Taqueria Valparaiso | O'Shea (19) | Transportation |
| 199 | O2014-4741 | Grant(s) of privilege in public way for Cosmo Superstore, Inc. | Cochran (20) | Transportation |
| 200 | O2014-4743 | Grant(s) of privilege in public way for Dolex Dollar Express, Inc. | Cochran (20) | Transportation |
| 201 | O2014-4745 | Grant(s) of privilege in public way for H&W Dental | Brookins (21) | Transportation |
| 202 | O2014-4746 | Grant(s) of privilege in public way for Restaurante Alanis Ltd. | Munoz (22) | Transportation |
| 203 | O2014-4747 | Grant(s) of privilege in public way for Allstate Insurance | Zalewski (23) | Transportation |
| 204 | O2014-4748 | Grant(s) of privilege in public way for Dunkin Donuts | Zalewski (23) | Transportation |
| 205 | O2014-4749 | Grant(s) of privilege in public way for Moran Body Shop | Zalewski (23) | Transportation |
| 206 | O2014-4751 | Grant(s) of privilege in public way for Ivory Cleaners | Chandler (24) | Transportation |

Legislation Referred to Committees at the Chicago City Council Meeting

5/28/2014

Section 3c - Aldermanic Introductions Regarding Unclassified Matters

| File # | Title | Sponsor(s) | Committee Referral |
|--------|---|----------------|--------------------|
| 207 | O2014-4752 Grant(s) of privilege in public way for La Azteca Paleteria | Chandler (24) | Transportation |
| 208 | O2014-4753 Grant(s) of privilege in public way for Rothchild Liquors | Chandler (24) | Transportation |
| 209 | O2014-4754 Grant(s) of privilege in public way for Cell Com of Chicago, Inc. | Solis (25) | Transportation |
| 210 | O2014-4756 Grant(s) of privilege in public way for Digital Green Sign | Solis (25) | Transportation |
| 211 | O2014-4758 Grant(s) of privilege in public way for Monterrey Security Consultants, Inc. | Solis (25) | Transportation |
| 212 | O2014-4759 Grant(s) of privilege in public way for Uncle Bob's Storage - banners | Solis (25) | Transportation |
| 213 | O2014-4766 Grant(s) of privilege in public way for Uncle Bob's Storage - signs | Solis (25) | Transportation |
| 214 | O2014-4769 Grant(s) of privilege in public way for La Canasta Bakery, Inc. | Maldonado (26) | Transportation |
| 215 | O2014-4289 Grant(s) of privilege in public way for Bert's Car Wash & Detail Center | Burnett (27) | Transportation |
| 216 | O2014-4294 Grant(s) of privilege in public way for Chicago Park District - landscapings | Burnett (27) | Transportation |
| 217 | O2014-4302 Grant(s) of privilege in public way for Chicago Park District - planter raillings | Burnett (27) | Transportation |
| 218 | O2014-4308 Grant(s) of privilege in public way for Chicago Park District - trees | Burnett (27) | Transportation |
| 219 | O2014-4313 Grant(s) of privilege in public way for De Cero | Burnett (27) | Transportation |
| 220 | O2014-4315 Grant(s) of privilege in public way for Empire Cooler Service, Inc. | Burnett (27) | Transportation |
| 221 | O2014-4317 Grant(s) of privilege in public way for Kaiser Tiger | Burnett (27) | Transportation |
| 222 | O2014-4320 Grant(s) of privilege in public way for Lou Malnati's Pizzeria | Burnett (27) | Transportation |
| 223 | O2014-4332 Grant(s) of privilege in public way for Michalik Funeral Home | Burnett (27) | Transportation |
| 224 | O2014-4335 Grant(s) of privilege in public way for Mr. Clarence L. Burch | Burnett (27) | Transportation |
| 225 | O2014-4383 Grant(s) of privilege in public way for Prairie Material | Burnett (27) | Transportation |
| 226 | O2014-4389 Grant(s) of privilege in public way for Roosevelt Square II Limited Partnership - 1302 W Roosevelt Rd | Burnett (27) | Transportation |
| 227 | O2014-4403 Grant(s) of privilege in public way for Roosevelt Square II Limited Partnership - 1328-1352 W Roosevelt Rd | Burnett (27) | Transportation |
| 228 | O2014-4412 Grant(s) of privilege in public way for Thalia Spice Asian Fusion Bistro - light fixtures | Burnett (27) | Transportation |
| 229 | O2014-4414 Grant(s) of privilege in public way for Thalia Spice Asian Fusion Bistro - signs | Burnett (27) | Transportation |
| 230 | O2014-4417 Grant(s) of privilege in public way for Transit | Burnett (27) | Transportation |

Legislation Referred to Committees at the Chicago City Council Meeting

5/28/2014

Section 3c - Aldermanic Introductions Regarding Unclassified Matters

| File # | Title | Sponsor(s) | Committee Referral | |
|--------|------------|--|--------------------|----------------|
| 231 | O2014-4426 | Grant(s) of privilege in public way for VCP Funding 111 LLC, VCP Series 1057 Grand - balconies | Burnett (27) | Transportation |
| 232 | O2014-4430 | Grant(s) of privilege in public way for VCP Funding 111 LLC, VCP Series 1057 Grand - bay windows | Burnett (27) | Transportation |
| 233 | O2014-4437 | Grant(s) of privilege in public way for VCP Funding 111 LLC, VCP Series 1057 Grand - fence | Burnett (27) | Transportation |
| 234 | O2014-4440 | Grant(s) of privilege in public way for VCP Funding 111 LLC, VCP Series 1057 Grand - staircase | Burnett (27) | Transportation |
| 235 | O2014-4449 | Grant(s) of privilege in public way for Westhaven Coin Laundry | Burnett (27) | Transportation |
| 236 | O2014-4454 | Grant(s) of privilege in public way for 167 N May Street - Chris Livieratos | Burnett (27) | Transportation |
| 237 | O2014-4322 | Grant(s) of privilege in public way for Madison Street Gold Exchange, Inc. | Ervin (28) | Transportation |
| 238 | O2014-4371 | Grant(s) of privilege in public way for Ogden, The | Ervin (28) | Transportation |
| 239 | O2014-4380 | Grant(s) of privilege in public way for Polk & Western, Inc. | Ervin (28) | Transportation |
| 240 | O2014-4465 | Grant(s) of privilege in public way for Angelo's Quick Stop | Graham (29) | Transportation |
| 241 | O2014-4467 | Grant(s) of privilege in public way for Barney's Pizza | Graham (29) | Transportation |
| 242 | O2014-4472 | Grant(s) of privilege in public way for Advantage MRI | Reboyras (30) | Transportation |
| 243 | O2014-4475 | Grant(s) of privilege in public way for Bristol Liquors, Inc. | Reboyras (30) | Transportation |
| 244 | O2014-4478 | Grant(s) of privilege in public way for EM Lounge | Reboyras (30) | Transportation |
| 245 | O2014-4480 | Grant(s) of privilege in public way for Podlasie | Reboyras (30) | Transportation |
| 246 | O2014-4486 | Grant(s) of privilege in public way for Taqueria La Oaxaquena | Reboyras (30) | Transportation |
| 247 | O2014-4490 | Grant(s) of privilege in public way for Advanced Medical Clinic | Suarez (31) | Transportation |
| 248 | O2014-4494 | Grant(s) of privilege in public way for Baskin Robbins/Dunkin Donuts | Suarez (31) | Transportation |
| 249 | O2014-4496 | Grant(s) of privilege in public way for Salgado Furniture, Inc. | Suarez (31) | Transportation |
| 250 | O2014-4502 | Grant(s) of privilege in public way for Bluelight | Waguespack (32) | Transportation |
| 251 | O2014-4504 | Grant(s) of privilege in public way for Goose Island Shrimp House, Inc. | Waguespack (32) | Transportation |
| 252 | O2014-4506 | Grant(s) of privilege in public way for Horween Leather Co. | Waguespack (32) | Transportation |
| 253 | O2014-4507 | Grant(s) of privilege in public way for Neil Kauffman | Waguespack (32) | Transportation |

Legislation Referred to Committees at the Chicago City Council Meeting

5/28/2014

Section 3c - Aldermanic Introductions Regarding Unclassified Matters

| File # | Title | Sponsor(s) | Committee Referral | |
|--------|------------|---|--------------------|----------------|
| 254 | O2014-4510 | Grant(s) of privilege in public way for North Community Bank | Waguespack (32) | Transportation |
| 255 | O2014-4518 | Grant(s) of privilege in public way for Roscoe Village Chamber of Commerce - 1819 W Belmont Ave | Waguespack (32) | Transportation |
| 256 | O2014-4523 | Grant(s) of privilege in public way for Roscoe Village Chamber of Commerce - 1900 W Belmont Ave | Waguespack (32) | Transportation |
| 257 | O2014-4525 | Grant(s) of privilege in public way for Roscoe Village Chamber of Commerce - 1948 W Belmont Ave | Waguespack (32) | Transportation |
| 258 | O2014-4530 | Grant(s) of privilege in public way for Roscoe Village Chamber of Commerce - 2058 W Belmont Ave | Waguespack (32) | Transportation |
| 259 | O2014-4532 | Grant(s) of privilege in public way for Roscoe Village Chamber of Commerce - 2059 W Belmont Ave | Waguespack (32) | Transportation |
| 260 | O2014-4537 | Grant(s) of privilege in public way for Roscoe Village Chamber of Commerce - 2159 W Belmont Ave | Waguespack (32) | Transportation |
| 261 | O2014-4541 | Grant(s) of privilege in public way for Roscoe Village Chamber of Commerce - 2200 W Belmont Ave | Waguespack (32) | Transportation |
| 262 | O2014-4547 | Grant(s) of privilege in public way for Roscoe Village Chamber of Commerce - 2300 W Belmont Ave | Waguespack (32) | Transportation |
| 263 | O2014-4550 | Grant(s) of privilege in public way for Roscoe Village Chamber of Commerce - 2332 W Belmont Ave | Waguespack (32) | Transportation |
| 264 | O2014-4553 | Grant(s) of privilege in public way for Shigeyo Henriquez | Waguespack (32) | Transportation |
| 265 | O2014-4556 | Grant(s) of privilege in public way for Sixteen Condo Assn. | Waguespack (32) | Transportation |
| 266 | O2014-4563 | Grant(s) of privilege in public way for Visual Cast Media | Waguespack (32) | Transportation |
| 267 | O2014-4568 | Grant(s) of privilege in public way for Elston Ace Hardware, Inc. | Mell (33) | Transportation |
| 268 | O2014-4571 | Grant(s) of privilege in public way for Lincoln Antique Mall | Mell (33) | Transportation |
| 269 | O2014-4575 | Grant(s) of privilege in public way for North Park University | Mell (33) | Transportation |
| 270 | O2014-4583 | Grant(s) of privilege in public way for North River Commission | Mell (33) | Transportation |
| 271 | O2014-4588 | Grant(s) of privilege in public way for Express Food Mart & Cellular | Austin (34) | Transportation |
| 272 | O2014-4595 | Grant(s) of privilege in public way for Magic Johnson Bridgescape Academy | Austin (34) | Transportation |
| 273 | O2014-4601 | Grant(s) of privilege in public way for Cafe Con Leche D'Noche | Colón (35) | Transportation |
| 274 | O2014-4602 | Grant(s) of privilege in public way for Fullerton Hotel | Colón (35) | Transportation |

Legislation Referred to Committees at the Chicago City Council Meeting

5/28/2014

Section 3c - Aldermanic Introductions Regarding Unclassified Matters

| File # | Title | Sponsor(s) | Committee Referral |
|--------|--|---------------|--------------------|
| 275 | O2014-4608 Grant(s) of privilege in public way for Kedzie Elston C.E., Inc. | Colón (35) | Transportation |
| 276 | O2014-4615 Grant(s) of privilege in public way for L' Patron - 2815 W Diversey Ave | Colón (35) | Transportation |
| 277 | O2014-4618 Grant(s) of privilege in public way for L' Patron - 2817 W Diversey Ave | Colón (35) | Transportation |
| 278 | O2014-4622 Grant(s) of privilege in public way for My Wireless Store 1021, Inc. | Mitts (37) | Transportation |
| 279 | O2014-4628 Grant(s) of privilege in public way for A. K. Auto Service, Inc. | Laurino (39) | Transportation |
| 280 | O2014-4634 Grant(s) of privilege in public way for Pearl Beauty | Laurino (39) | Transportation |
| 281 | O2014-4772 Grant(s) of privilege in public way for New Chicago Restaurant | O'Connor (40) | Transportation |
| 282 | O2014-4774 Grant(s) of privilege in public way for Scooterworks USA | O'Connor (40) | Transportation |
| 283 | O2014-4776 Grant(s) of privilege in public way for Superior Super Auto Wash | O'Connor (40) | Transportation |
| 284 | O2014-4778 Grant(s) of privilege in public way for Lehigh Dental Care Ltd. | O'Connor (41) | Transportation |
| 285 | O2014-4781 Grant(s) of privilege in public way for Tricoci University of Beauty Culture LLC | O'Connor (41) | Transportation |
| 286 | O2014-4783 Grant(s) of privilege in public way for Argo Tea | Reilly (42) | Transportation |
| 287 | O2014-4784 Grant(s) of privilege in public way for Bank of American/LaSalle | Reilly (42) | Transportation |
| 288 | O2014-4789 Grant(s) of privilege in public way for Bar Toma | Reilly (42) | Transportation |
| 289 | O2014-4791 Grant(s) of privilege in public way for Boker Investment Management, Inc. | Reilly (42) | Transportation |
| 290 | O2014-4793 Grant(s) of privilege in public way for Camper | Reilly (42) | Transportation |
| 291 | O2014-4795 Grant(s) of privilege in public way for Chicago Marriott Downtown | Reilly (42) | Transportation |
| 292 | O2014-4796 Grant(s) of privilege in public way for Capital One 360 | Reilly (42) | Transportation |
| 293 | O2014-4799 Grant(s) of privilege in public way for Courtyard by Marriott Chicago | Reilly (42) | Transportation |
| 294 | O2014-4801 Grant(s) of privilege in public way for East Bank Club - light fixtures | Reilly (42) | Transportation |
| 295 | O2014-4803 Grant(s) of privilege in public way for East Bank Club - security camera | Reilly (42) | Transportation |
| 296 | O2014-4807 Grant(s) of privilege in public way for Eataly | Reilly (42) | Transportation |
| 297 | O2014-4809 Grant(s) of privilege in public way for Equity Office Properties Management Corporation | Reilly (42) | Transportation |
| 298 | O2014-4811 Grant(s) of privilege in public way for Gibsons LLC | Reilly (42) | Transportation |
| 299 | O2014-4813 Grant(s) of privilege in public way for GLL Properties 444 North Michigan L.P | Reilly (42) | Transportation |

Legislation Referred to Committees at the Chicago City Council Meeting

5/28/2014

Section 3c - Aldermanic Introductions Regarding Unclassified Matters

| File # | Title | Sponsor(s) | Committee Referral |
|--------|---|-------------|--------------------|
| 300 | O2014-4815 Grant(s) of privilege in public way for Hotel Allegro - earth retention systems | Reilly (42) | Transportation |
| 301 | O2014-4818 Grant(s) of privilege in public way for Hotel Allegro - flagpoles | Reilly (42) | Transportation |
| 302 | O2014-4819 Grant(s) of privilege in public way for Hotel Allegro - vaults | Reilly (42) | Transportation |
| 303 | O2014-4822 Grant(s) of privilege in public way for Hugo's Frog Bar | Reilly (42) | Transportation |
| 304 | O2014-4824 Grant(s) of privilege in public way for Hyatt Place | Reilly (42) | Transportation |
| 305 | O2014-4825 Grant(s) of privilege in public way for KHRG Allegro LLC | Reilly (42) | Transportation |
| 306 | O2014-4826 Grant(s) of privilege in public way for Macy's Retail Holdings, Inc. | Reilly (42) | Transportation |
| 307 | O2014-4827 Grant(s) of privilege in public way for Madison LaSalle Partners LLC | Reilly (42) | Transportation |
| 308 | O2014-4828 Grant(s) of privilege in public way for Maggiano's Little Italy - light fixtures | Reilly (42) | Transportation |
| 309 | O2014-4831 Grant(s) of privilege in public way for Maggiano's Little Italy - park bench | Reilly (42) | Transportation |
| 310 | O2014-4833 Grant(s) of privilege in public way for Maggiano's Little Italy - sign | Reilly (42) | Transportation |
| 311 | O2014-4836 Grant(s) of privilege in public way for MB Financial Bank | Reilly (42) | Transportation |
| 312 | O2014-4838 Grant(s) of privilege in public way for Millennium Trolley Tours LLC | Reilly (42) | Transportation |
| 313 | O2014-4839 Grant(s) of privilege in public way for Northwestern University/Chicago Campus - Privilege No. 1112817 | Reilly (42) | Transportation |
| 314 | O2014-4841 Grant(s) of privilege in public way for Northwestern University/Chicago Campus - sheetings | Reilly (42) | Transportation |
| 315 | O2014-4844 Grant(s) of privilege in public way for Northwestern University/Chicago Campus - tree grates | Reilly (42) | Transportation |
| 316 | O2014-4869 Grant(s) of privilege in public way for Original Hair Designers, The | Reilly (42) | Transportation |
| 317 | O2014-4870 Grant(s) of privilege in public way for River Point LLC - foundation support | Reilly (42) | Transportation |
| 318 | O2014-4871 Grant(s) of privilege in public way for River Point LLC - irrigation system | Reilly (42) | Transportation |
| 319 | O2014-4872 Grant(s) of privilege in public way for River Point LLC - staircase | Reilly (42) | Transportation |
| 320 | O2014-4873 Grant(s) of privilege in public way for Saks Fifth Avenue | Reilly (42) | Transportation |
| 321 | O2014-4874 Grant(s) of privilege in public way for Standard Parking | Reilly (42) | Transportation |
| 322 | O2014-4875 Grant(s) of privilege in public way for Thor Palmer House Hotel & Shops LLC | Reilly (42) | Transportation |

Legislation Referred to Committees at the Chicago City Council Meeting

5/28/2014

Section 3c - Aldermanic Introductions Regarding Unclassified Matters

| File # | Title | Sponsor(s) | Committee Referral | |
|--------|------------|--|--------------------|----------------|
| 323 | O2014-4876 | Grant(s) of privilege in public way for Tower 10 Glades LLC | Reilly (42) | Transportation |
| 324 | O2014-4877 | Grant(s) of privilege in public way for Tumi Stores, Inc. | Reilly (42) | Transportation |
| 325 | O2014-4878 | Grant(s) of privilege in public way for Northwestern University/Chicago Campus - Privilege No. 1112341 | Reilly (42) | Transportation |
| 326 | O2014-4879 | Grant(s) of privilege in public way for Walton on the Park LLC | Reilly (42) | Transportation |
| 327 | O2014-4880 | Grant(s) of privilege in public way for 131 S Dearborn LLC | Reilly (42) | Transportation |
| 328 | O2014-4633 | Grant(s) of privilege in public way for David Young-Jeff Peters - planter | Smith (43) | Transportation |
| 329 | O2014-4653 | Grant(s) of privilege in public way for David Young-Jeff Peters - fence | Smith (43) | Transportation |
| 330 | O2014-4655 | Grant(s) of privilege in public way for Great Clips | Smith (43) | Transportation |
| 331 | O2014-4656 | Grant(s) of privilege in public way for New Balance Chicago | Smith (43) | Transportation |
| 332 | O2014-4657 | Grant(s) of privilege in public way for Public Storage | Smith (43) | Transportation |
| 333 | O2014-4788 | Grant(s) of privilege in public way for Exedus II | Tunney (44) | Transportation |
| 334 | O2014-4797 | Grant(s) of privilege in public way for Teavana No. 21920 | Tunney (44) | Transportation |
| 335 | O2014-4812 | Grant(s) of privilege in public way for Annoyance Productions | Tunney (44) | Transportation |
| 336 | O2014-4814 | Grant(s) of privilege in public way for Bel-Port Food & Liquor, Inc. | Tunney (44) | Transportation |
| 337 | O2014-4816 | Grant(s) of privilege in public way for Lakeview Ace Hardware, Inc. | Tunney (44) | Transportation |
| 338 | O2014-4820 | Grant(s) of privilege in public way for O'Malley's Liquor Kitchen | Tunney (44) | Transportation |
| 339 | O2014-4821 | Grant(s) of privilege in public way for Secrets | Tunney (44) | Transportation |
| 340 | O2014-4823 | Grant(s) of privilege in public way for Standard Bank & Trust Company | Tunney (44) | Transportation |
| 341 | O2014-4785 | Grant(s) of privilege in public way for Accelerated Rehabilitation Centers | Arena (45) | Transportation |
| 342 | O2014-4787 | Grant(s) of privilege in public way for Central Milwaukee Currency Exchange, Inc. | Arena (45) | Transportation |
| 343 | O2014-4790 | Grant(s) of privilege in public way for Foremost Liquor Center | Arena (45) | Transportation |
| 344 | O2014-4792 | Grant(s) of privilege in public way for Irving-Cicero Currency Exchange, Inc. | Arena (45) | Transportation |
| 345 | O2014-4794 | Grant(s) of privilege in public way for Kingston Reflexology LLC | Arena (45) | Transportation |
| 346 | O2014-4798 | Grant(s) of privilege in public way for Unique Travel | Arena (45) | Transportation |
| 347 | O2014-4800 | Grant(s) of privilege in public way for Valbona's Beauty Salon | Arena (45) | Transportation |

Legislation Referred to Committees at the Chicago City Council Meeting

5/28/2014

Section 3c - Aldermanic Introductions Regarding Unclassified Matters

| File # | Title | Sponsor(s) | Committee Referral | |
|--------|------------|---|--------------------|----------------|
| 348 | O2014-4802 | Grant(s) of privilege in public way for Boost Mobile - banner | Cappleman (46) | Transportation |
| 349 | O2014-4804 | Grant(s) of privilege in public way for Boost Mobile - sign | Cappleman (46) | Transportation |
| 350 | O2014-4805 | Grant(s) of privilege in public way for Dearborn Food Mart | Cappleman (46) | Transportation |
| 351 | O2014-4806 | Grant(s) of privilege in public way for Fifth Third Bank | Cappleman (46) | Transportation |
| 352 | O2014-4808 | Grant(s) of privilege in public way for Language Stars LLC | Cappleman (46) | Transportation |
| 353 | O2014-4810 | Grant(s) of privilege in public way for US Wireless Communications | Cappleman (46) | Transportation |
| 354 | O2014-4764 | Grant(s) of privilege in public way for ATI Physical Therapy | Pawar (47) | Transportation |
| 355 | O2014-4765 | Grant(s) of privilege in public way for Domestic Linen Supply Co., Inc. | Pawar (47) | Transportation |
| 356 | O2014-4767 | Grant(s) of privilege in public way for Half Acre Beer Company | Pawar (47) | Transportation |
| 357 | O2014-4768 | Grant(s) of privilege in public way for Julius Meinl | Pawar (47) | Transportation |
| 358 | O2014-4770 | Grant(s) of privilege in public way for Mrs Murphys and Sons Irish Bistro | Pawar (47) | Transportation |
| 359 | O2014-4771 | Grant(s) of privilege in public way for State Farm Insurance | Pawar (47) | Transportation |
| 360 | O2014-4773 | Grant(s) of privilege in public way for Strongbox | Pawar (47) | Transportation |
| 361 | O2014-4775 | Grant(s) of privilege in public way for Thai Oscar | Pawar (47) | Transportation |
| 362 | O2014-4777 | Grant(s) of privilege in public way for Bryn Mawr Belle Shore LP | Osterman (48) | Transportation |
| 363 | O2014-4779 | Grant(s) of privilege in public way for Bryn Mawr Sheridan | Osterman (48) | Transportation |
| 364 | O2014-4780 | Grant(s) of privilege in public way for Indie Cafe | Osterman (48) | Transportation |
| 365 | O2014-4782 | Grant(s) of privilege in public way for Mariano's No. 8522 | Osterman (48) | Transportation |
| 366 | O2014-4755 | Grant(s) of privilege in public way for Morland Coin Laundry | Moore (49) | Transportation |
| 367 | O2014-4757 | Grant(s) of privilege in public way for Autozone No. 5247 | Silverstein (50) | Transportation |
| 368 | O2014-4760 | Grant(s) of privilege in public way for K.R.K. International Corporation | Silverstein (50) | Transportation |
| 369 | O2014-4762 | Grant(s) of privilege in public way for New Devon Video | Silverstein (50) | Transportation |
| 370 | O2014-4763 | Grant(s) of privilege in public way for Pride Sushi and Thai | Silverstein (50) | Transportation |

Grant(s) of Privilege - Amend

| | | | | |
|-----|------------|--|--------------|----------------|
| 371 | O2014-4476 | Amendment of grant(s) of privilege in public way to Belly Q/Urban Belly II | Burnett (27) | Transportation |
|-----|------------|--|--------------|----------------|

Legislation Referred to Committees at the Chicago City Council Meeting

5/28/2014

Section 3c - Aldermanic Introductions Regarding Unclassified Matters

| File # | Title | Sponsor(s) | Committee Referral | |
|--|------------|--|--------------------|-------------------------------|
| 372 | O2014-4304 | Amendment of grant(s) of privilege in public way to NM Project Company LLC - six columns | Reilly (42) | Transportation |
| 373 | O2014-4372 | Amendment of grant(s) of privilege in public way to NM Project Company LLC - four archs | Reilly (42) | Transportation |
| 374 | O2014-4381 | Amendment of grant(s) of privilege in public way to NM Project Company LLC - nine stone copings | Reilly (42) | Transportation |
| 375 | O2014-4386 | Amendment of grant(s) of privilege in public way to NM Project Company LLC - four sculptures | Reilly (42) | Transportation |
| 376 | O2014-4394 | Amendment of grant(s) of privilege in public way to NM Project Company LLC - 12 building projections | Reilly (42) | Transportation |
| 377 | O2014-4402 | Amendment of grant(s) of privilege in public way to NM Project Company LLC - six cornices | Reilly (42) | Transportation |
| 378 | O2014-4410 | Amendment of grant(s) of privilege in public way to NM Project Company LLC - 12 exterior mounts | Reilly (42) | Transportation |
| 379 | O2014-4415 | Amendment of grant(s) of privilege in public way to NM Project Company LLC - four balconies | Reilly (42) | Transportation |
| 380 | O2014-4425 | Amendment of grant(s) of privilege in public way to NM Project Company LLC - four facades | Reilly (42) | Transportation |
| 381 | O2014-4441 | Amendment of grant(s) of privilege in public way to NM Project Company LLC - one sheeting | Reilly (42) | Transportation |
| 382 | O2014-4445 | Amendment of grant(s) of privilege in public way to NM Project Company LLC - one elevator | Reilly (42) | Transportation |
| 383 | O2014-4470 | Amendment of grant(s) of privilege in public way to NM Project Company LLC - one vault | Reilly (42) | Transportation |
| 384 | O2014-4474 | Amendment of grant(s) of privilege in public way to Next Randolph & Wells Park | Reilly (42) | Transportation |
| 385 | O2014-4295 | Amendment of grant(s) of privilege in public way to Alibis | Silverstein (50) | Transportation |
| Historical Landmark Fee Waiver(s) | | | | |
| 386 | Or2014-251 | Historical landmark fee waiver for 518 W Fullerton Pkwy | Smith (43) | Zoning <i>Redacted Record</i> |
| Honorary Street Designation(s) | | | | |
| 387 | O2014-4237 | Honorary street designation as "Edwin 'Ode' Boska Way" | Moreno (1) | Transportation |
| 388 | O2014-4227 | Honorary street designation as "Officer Nikki Bostic-Jones Way" | Chandler (24) | Transportation |
| 389 | O2014-4214 | Community street designation sign as "Welcome to Polish Village" | Colón (35) | Transportation |

Legislation Referred to Committees at the Chicago City Council Meeting

5/28/2014

Section 3c - Aldermanic Introductions Regarding Unclassified Matters

| File # | Title | Sponsor(s) | Committee Referral | |
|------------------------------------|------------|--|--|----------------|
| 390 | O2014-4223 | Honorary designation as "Chopin Plaza" in area bounded by N Milwaukee Ave, N Elston Ave N Melvina Ave and W Holbrook St | Laurino (39) | Transportation |
| 391 | O2014-4230 | Honorary street designation as "Honorary Women and Children First Way" | Osterman (48) | Transportation |
| 392 | Or2014-240 | Honorary street designation as "Honorary Ziaur Rahman Way" | Moore (49) | Transportation |
| Journal Correction(s) | | | | |
| 393 | O2014-4208 | Correction of City Council Journal of Proceedings for April 30, 2014 | Harris (8) | Rules |
| Municipal Code Amendment(s) | | | | |
| 394 | O2014-4252 | Amendment of Municipal Code Chapter 2-154 by adding new Section 2-154-017 titled "Diversity in Non-Minority-Owned Firms Disclosure Ordinance" | Thomas (17) Austin (34) Burnett (27) Graham (29) Ervin (28) Mitts (37) Brookins (21) Cochran (20) Holmes (7) Harris (8) Sawyer (6) Chandler (24) Lane (18) Dowell (3) Beale (9) Foulkes (15) Thompson (16) | Finance |
| 395 | O2014-4225 | Amendment of Municipal Code Section 17-6-0403 concerning planned development approval for large entertainment and spectator sport venues in Planned Manufacturing District No. 11a | Solis (25) | Zoning |
| 396 | O2014-4212 | Amendment of Municipal Code Titles 4, 7 and 10 concerning mobile prepared food vendors | Maldonado (26) | License |
| 397 | O2014-4161 | Amendment of Municipal Code Chapter 17-11 extending landscape requirement compliance date for accessory vehicular use areas | Reboyas (30) | Zoning |
| 398 | O2014-4232 | Amendment of previous ordinance concerning construction funding for City College facilities | Suarez (31) Burke (14) | Finance |
| 399 | O2014-4203 | Amendment of Municipal Code Chapter 2-159 concerning Adjacent Neighbors Land Acquisition Program | Austin (34) | Housing |
| 400 | O2014-4233 | Amendment of Section 4-64-110 modifying retail tobacco dealer's license issuance or renewal requirements | Tunney (44) | License |

Legislation Referred to Committees at the Chicago City Council Meeting

5/28/2014

Section 3c - Aldermanic Introductions Regarding Unclassified Matters

| File # | Title | Sponsor(s) | Committee Referral | |
|-------------------------|------------|---|---|-----------------------|
| 401 | O2014-4251 | Amendment of Municipal Code Title 4 by adding new Chapter 4-404 titled "Chicago Minimum Wage" | Arena (45) Sawyer (6) Moreno (1) Foulkes (15) Waguespack (32) Burnett (27) Holmes (7) Chandler (24) Moore (49) Graham (29) Lane (18) Fioretti (2) Hairston (5) Munoz (22) Sposato (36) Solis (25) Ervin (28) Cochran (20) Colón (35) Thomas (17) Maldonado (26) | Workforce Development |
| 402 | O2014-4234 | Amendment of Municipal Code Section 4-6-230(g)(5) concerning booting of motor vehicles within 47th Ward | Pawar (47) | License |
| Sidewalk Cafe(s) | | | | |
| 403 | O2014-4277 | Sidewalk cafe(s) for Craft Pizza | Moreno (1) | Transportation |
| 404 | O2014-4279 | Sidewalk cafe(s) for Hash | Moreno (1) | Transportation |
| 405 | O2014-4281 | Sidewalk cafe(s) for Koko's Mediterranean Grill | Moreno (1) | Transportation |
| 406 | O2014-4286 | Sidewalk cafe(s) for La Strade Cafe | Moreno (1) | Transportation |
| 407 | O2014-4291 | Sidewalk cafe(s) for Las Islas Marias | Moreno (1) | Transportation |
| 408 | O2014-4305 | Sidewalk cafe(s) for Mexique | Moreno (1) | Transportation |
| 409 | O2014-4312 | Sidewalk cafe(s) for Runa Japanese | Moreno (1) | Transportation |
| 410 | O2014-4316 | Sidewalk cafe(s) for Shambles Bar | Moreno (1) | Transportation |
| 411 | O2014-4319 | Sidewalk cafe(s) for Xoco | Moreno (1) | Transportation |
| 412 | O2014-4323 | Sidewalk cafe(s) for Giordano's Restaurant | Fioretti (2) | Transportation |
| 413 | O2014-4326 | Sidewalk cafe(s) for Meli Cafe on Dearborn | Fioretti (2) | Transportation |
| 414 | O2014-4338 | Sidewalk cafe(s) for Al's Beef | Fioretti (2) | Transportation |
| 415 | O2014-4340 | Sidewalk cafe(s) for Acadia Restaurant | Fioretti (2) | Transportation |
| 416 | O2014-4345 | Sidewalk cafe(s) for Epples Restaurant | Fioretti (2) | Transportation |
| 417 | O2014-4351 | Sidewalk cafe(s) for Waffles | Fioretti (2) | Transportation |
| 418 | O2014-4358 | Sidewalk cafe(s) for Ellie's | O'Shea (19) | Transportation |
| 419 | O2014-4362 | Sidewalk cafe(s) for Jamba Juice | Solis (25) | Transportation |
| 420 | O2014-4368 | Sidewalk cafe(s) for Cafe Colao | Maldonado (26) | Transportation |

Legislation Referred to Committees at the Chicago City Council Meeting

5/28/2014

Section 3c - Aldermanic Introductions Regarding Unclassified Matters

| File # | Title | Sponsor(s) | Committee Referral |
|--------|---|-----------------|--------------------|
| 421 | O2014-4374 Sidewalk cafe(s) for Lockdown | Maldonado (26) | Transportation |
| 422 | O2014-4377 Sidewalk cafe(s) for Papa's Cache Sabroso, Inc. | Maldonado (26) | Transportation |
| 423 | O2014-4388 Sidewalk cafe(s) for Upton's Naturals Co. | Maldonado (26) | Transportation |
| 424 | O2014-4393 Sidewalk cafe(s) for Vainilla Bean Bake Shop, Inc. | Maldonado (26) | Transportation |
| 425 | O2014-4397 Sidewalk cafe(s) for Arista Foods | Burnett (27) | Transportation |
| 426 | O2014-4400 Sidewalk cafe(s) for Glazed and Infused | Burnett (27) | Transportation |
| 427 | O2014-4405 Sidewalk cafe(s) for Viaggio | Burnett (27) | Transportation |
| 428 | O2014-4411 Sidewalk cafe(s) for Vinnies Sub Shop | Burnett (27) | Transportation |
| 429 | O2014-4419 Sidewalk cafe(s) for Mambo Cafe | Reboyras (30) | Transportation |
| 430 | O2014-4422 Sidewalk cafe(s) for Bird's Nest | Waguespack (32) | Transportation |
| 431 | O2014-4428 Sidewalk cafe(s) for Butcher & The Burger | Waguespack (32) | Transportation |
| 432 | O2014-4432 Sidewalk cafe(s) for Fairways | Waguespack (32) | Transportation |
| 433 | O2014-4443 Sidewalk cafe(s) for Las Tablas on Lincoln | Waguespack (32) | Transportation |
| 434 | O2014-4446 Sidewalk cafe(s) for Sofra Turkish Kitchen | Waguespack (32) | Transportation |
| 435 | O2014-4450 Sidewalk cafe(s) for Antojitos Majicos | Mell (33) | Transportation |
| 436 | O2014-4455 Sidewalk cafe(s) for Alaska Paleteria Y Neveria | Colón (35) | Transportation |
| 437 | O2014-4457 Sidewalk cafe(s) for Logan Theatre, The | Colón (35) | Transportation |
| 438 | O2014-4460 Sidewalk cafe(s) for Osteria Langhe | Colón (35) | Transportation |
| 439 | O2014-4464 Sidewalk cafe(s) for Caffè Italia | Sposato (36) | Transportation |
| 440 | O2014-4468 Sidewalk cafe(s) for Euro Cafe | Sposato (36) | Transportation |
| 441 | O2014-4471 Sidewalk cafe(s) for Leadbelly | Cullerton (38) | Transportation |
| 442 | O2014-4477 Sidewalk cafe(s) for El Restaurante Tinajon | Laurino (39) | Transportation |
| 443 | O2014-4481 Sidewalk cafe(s) for Sunset Caffè | O'Connor (40) | Transportation |
| 444 | O2014-4505 Sidewalk cafe(s) for Chicago French Market | Reilly (42) | Transportation |
| 445 | O2014-4508 Sidewalk cafe(s) for Corner Bakery Cafe | Reilly (42) | Transportation |
| 446 | O2014-4521 Sidewalk cafe(s) for Dunkin Donuts - 100 W Randolph St | Reilly (42) | Transportation |
| 447 | O2014-4522 Sidewalk cafe(s) for Dunkin Donuts - 223 W Washington St | Reilly (42) | Transportation |
| 448 | O2014-4528 Sidewalk cafe(s) for Dunkin Donuts - 205 W Randolph St | Reilly (42) | Transportation |
| 449 | O2014-4534 Sidewalk cafe(s) for Freshii - 50 E Washington St | Reilly (42) | Transportation |
| 450 | O2014-4538 Sidewalk cafe(s) for Freshii -200 W Randolph St | Reilly (42) | Transportation |
| 451 | O2014-4542 Sidewalk cafe(s) for Howl at the Moon | Reilly (42) | Transportation |
| 452 | O2014-4544 Sidewalk cafe(s) for Jamba Juice | Reilly (42) | Transportation |

Legislation Referred to Committees at the Chicago City Council Meeting

5/28/2014

Section 3c - Aldermanic Introductions Regarding Unclassified Matters

| File # | Title | Sponsor(s) | Committee Referral |
|--------|--|----------------|--------------------|
| 453 | O2014-4546 Sidewalk cafe(s) for Jersey Mikes | Reilly (42) | Transportation |
| 454 | O2014-4549 Sidewalk cafe(s) for Maggiano's Little Italy | Reilly (42) | Transportation |
| 455 | O2014-4554 Sidewalk cafe(s) for McCormick & Schmick's Seafood Restaurant | Reilly (42) | Transportation |
| 456 | O2014-4555 Sidewalk cafe(s) for Merlo on Maple | Reilly (42) | Transportation |
| 457 | O2014-4559 Sidewalk cafe(s) for Piccolo Sogno Due | Reilly (42) | Transportation |
| 458 | O2014-4562 Sidewalk cafe(s) for Pizzeria Uno Chicago Bar & Grill | Reilly (42) | Transportation |
| 459 | O2014-4570 Sidewalk cafe(s) for Red Robin's Burger Works | Reilly (42) | Transportation |
| 460 | O2014-4577 Sidewalk cafe(s) for Fiesta Mexicana Restaurant | Smith (43) | Transportation |
| 461 | O2014-4581 Sidewalk cafe(s) for Hi-Tops | Smith (43) | Transportation |
| 462 | O2014-4587 Sidewalk cafe(s) for Le Pain Quotidien | Smith (43) | Transportation |
| 463 | O2014-4594 Sidewalk cafe(s) for McGee's Tavern & Grille | Smith (43) | Transportation |
| 464 | O2014-4599 Sidewalk cafe(s) for Pizano's Pizza & Pasta On Lincoln | Smith (43) | Transportation |
| 465 | O2014-4604 Sidewalk cafe(s) for Woodie's Flat | Smith (43) | Transportation |
| 466 | O2014-4607 Sidewalk cafe(s) for Beezzee | Tunney (44) | Transportation |
| 467 | O2014-4612 Sidewalk cafe(s) for Efes Restaurant | Tunney (44) | Transportation |
| 468 | O2014-4617 Sidewalk cafe(s) for Falafill | Tunney (44) | Transportation |
| 469 | O2014-4621 Sidewalk cafe(s) for Johnny O'Hagan's | Tunney (44) | Transportation |
| 470 | O2014-4673 Sidewalk cafe(s) for Joys | Tunney (44) | Transportation |
| 471 | O2014-4675 Sidewalk cafe(s) for MFK | Tunney (44) | Transportation |
| 472 | O2014-4676 Sidewalk cafe(s) for Michael Diversey's | Tunney (44) | Transportation |
| 473 | O2014-4678 Sidewalk cafe(s) for O'Malley's Liquor Kitchen | Tunney (44) | Transportation |
| 474 | O2014-4682 Sidewalk cafe(s) for Ping Pong | Tunney (44) | Transportation |
| 475 | O2014-4684 Sidewalk cafe(s) for Redmond's | Tunney (44) | Transportation |
| 476 | O2014-4685 Sidewalk cafe(s) for Spencer's Jolly Posh Foods | Tunney (44) | Transportation |
| 477 | O2014-4688 Sidewalk cafe(s) for Tac Quick | Tunney (44) | Transportation |
| 478 | O2014-4689 Sidewalk cafe(s) for Wakamono | Tunney (44) | Transportation |
| 479 | O2014-4691 Sidewalk cafe(s) for Margaret's | Arena (45) | Transportation |
| 480 | O2014-4694 Sidewalk cafe(s) for Rasmus | Arena (45) | Transportation |
| 481 | O2014-4696 Sidewalk cafe(s) for Baker & Nosh Bakery | Cappleman (46) | Transportation |
| 482 | O2014-4697 Sidewalk cafe(s) for Coronas Coffee II | Cappleman (46) | Transportation |
| 483 | O2014-4700 Sidewalk cafe(s) for Taverna 750 | Cappleman (46) | Transportation |
| 484 | O2014-4348 Sidewalk cafe(s) for Revolver | Pawar (47) | Transportation |

Legislation Referred to Committees at the Chicago City Council Meeting

5/28/2014

Section 3c - Aldermanic Introductions Regarding Unclassified Matters

| File # | Title | Sponsor(s) | Committee Referral |
|-----------------------------|---|---------------|--------------------|
| 485 | O2014-4701 Sidewalk cafe(s) for Chicago Grind | Osterman (48) | Transportation |
| 486 | O2014-4703 Sidewalk cafe(s) for Demera Ethiopian Restaurant | Osterman (48) | Transportation |
| 487 | O2014-4704 Sidewalk cafe(s) for Fiesta Mexicana Corp. | Osterman (48) | Transportation |
| 488 | O2014-4708 Sidewalk cafe(s) for La Fonda Latino Grill | Osterman (48) | Transportation |
| 489 | O2014-4711 Sidewalk cafe(s) for Chuckie's | Moore (49) | Transportation |
| Sign(s)/Signboard(s) | | | |
| 490 | Or2014-242 Issuance of permits for sign(s)/signboard(s) at 829 S Wabash Ave | Fioretti (2) | Zoning |
| 491 | Or2014-228 Issuance of permits for sign(s)/signboard(s) at 9000 S Stony Island Ave | Harris (8) | Zoning |
| 492 | Or2014-229 Issuance of permits for sign(s)/signboard(s) at 2201 S Halsted St - north wall | Balcer (11) | Zoning |
| 493 | Or2014-230 Issuance of permits for sign(s)/signboard(s) at 2201 S Halsted St - southeast wall | Balcer (11) | Zoning |
| 494 | Or2014-225 Issuance of permits for sign(s)/signboard(s) at 7601 S Cicero Ave - 502 sq. ft. | Lane (18) | Zoning |
| 495 | Or2014-226 Issuance of permits for sign(s)/signboard(s) at 7601 S Cicero Ave - 278 sq. ft. | Lane (18) | Zoning |
| 496 | Or2014-231 Issuance of permits for sign(s)/signboard(s) at 1100 S Canal St - sign C1 | Solis (25) | Zoning |
| 497 | Or2014-232 Issuance of permits for sign(s)/signboard(s) at 1100 S Canal St - sign C2 | Solis (25) | Zoning |
| 498 | Or2014-233 Issuance of permits for sign(s)/signboard(s) at 1100 S Canal St - sign C3 | Solis (25) | Zoning |
| 499 | Or2014-234 Issuance of permits for sign(s)/signboard(s) at 1100 S Canal St - sign C4 | Solis (25) | Zoning |
| 500 | Or2014-235 Issuance of permits for sign(s)/signboard(s) at 1100 S Canal St - sign C5 | Solis (25) | Zoning |
| 501 | Or2014-236 Issuance of permits for sign(s)/signboard(s) at 1100 S Canal St - 137 sq. ft. - sign 1 | Solis (25) | Zoning |
| 502 | Or2014-237 Issuance of permits for sign(s)/signboard(s) at 1100 S Canal St - 137 sq. ft. - sign 2 | Solis (25) | Zoning |
| 503 | Or2014-238 Issuance of permits for sign(s)/signboard(s) at 1100 S Canal St - 137 sq. ft. - sign B1 | Solis (25) | Zoning |
| 504 | Or2014-239 Issuance of permits for sign(s)/signboard(s) at 1100 S Canal St - 137 sq. ft./49 ft. above grade | Solis (25) | Zoning |
| 505 | Or2014-241 Issuance of permits for sign(s)/signboard(s) at 2333 W Madison St | Burnett (27) | Zoning |
| 506 | Or2014-248 Issuance of permits for sign(s)/signboard(s) at 821 W Evergreen Ave - 560 sq. ft. | Burnett (27) | Zoning |
| 507 | Or2014-249 Issuance of permits for sign(s)/signboard(s) at 1333 N Kingsbury St | Burnett (27) | Zoning |
| 508 | Or2014-250 Issuance of permits for sign(s)/signboard(s) at 1717 W 115th St | Austin (34) | Zoning |
| 509 | Or2014-245 Issuance of permits for sign(s)/signboard(s) at 737 N Michigan Ave | Reilly (42) | Zoning |

Legislation Referred to Committees at the Chicago City Council Meeting

5/28/2014

Section 3c - Aldermanic Introductions Regarding Unclassified Matters

| File # | Title | Sponsor(s) | Committee Referral | |
|--------|------------|--|--------------------|--------|
| 510 | Or2014-246 | Issuance of permits for sign(s)/signboard(s) 549 N Wells St - north elevation | Reilly (42) | Zoning |
| 511 | Or2014-247 | Issuance of permits for sign(s)/signboard(s) at 549 N Wells St - west elevation | Reilly (42) | Zoning |
| 512 | Or2014-227 | Issuance of permits for sign(s)/signboard(s) at 3401 N Clark St | Tunney (44) | Zoning |
| 513 | Or2014-243 | Issuance of permits for sign(s)/signboard(s) at 3046 N Halsted St | Tunney (44) | Zoning |
| 514 | Or2014-216 | Issuance of permits for sign(s)/signboard(s) at 4646 N Marine Dr | Cappleman (46) | Zoning |
| 515 | Or2014-244 | Issuance of permits for sign(s)/signboard(s) at 3300 N Campbell Ave | Pawar (47) | Zoning |



City of Chicago



O2014-4205

Office of the City Clerk

Document Tracking Sheet

Meeting Date: 5/28/2014

Sponsor(s): Harris (8)

Type: Ordinance

Title: Amendment of Municipal Code Sections 4-60-022 and 4-60-023 to disallow additional alcoholic liquor & package good licenses on various portions within 8th Ward

Committee(s) Assignment: Committee on License and Consumer Protection

ORDINANCE

BE IT ORDAINED BY THE CITY COUNCIL OF THE CITY OF CHICAGO:

SECTION 1. The City Council finds that the areas described in Section 2 through 5 of this ordinance are adversely affected by the over-concentration of businesses licensed to sell alcoholic liquor within and near the areas.

SECTION 2. Section 4-60-022 of the Municipal Code of Chicago is hereby amended by replacing subsection 4-60-022 (8.41), which was previously deleted as shown in the Journal of Proceedings of October 3, 2012 at pages 35388 through 35339, with the following underscored text:

4-60-022 (8.41) On Stony Island Avenue, from 87th Street to 91st Street.

SECTION 3. Section 4-60-023 of the Municipal Code of Chicago is hereby amended by replacing subsection 4-60-023 (8.20), which was previously deleted as shown in the Journal of Proceedings of May 9, 2012 at pages 26712 through 26713, with the following underscored text:

4-60-023 (8.20) On 87th Street, from Yates Avenue to Paxton Avenue.

SECTION 4. Section 4-60-023 of the Municipal Code of Chicago is hereby amended by replacing subsection 4-60-023 (8.28), which was previously deleted as shown in the Journal of Proceedings of April 10, 2013 at pages 51207 through 51209, with the following underscored text:

4-60-023 (8.28) On 95th Street, from Jeffrey Avenue to the line of Cregier Avenue
(extended).

SECTION 5. Section 4-60-023 of the Municipal Code of Chicago is hereby amended by replacing subsection 4-60-023 (8.42(a)), which was previously deleted as shown in the Journal of Proceedings of July 29, 2009 at pages 67876 through 67878, with the following underscored text:

4-60-023 (8.42(a)) On Stony Island Avenue, from 87th Street to 89th Street.

SECTION 6. This ordinance shall be in full force and effect from and after its passage and publication.



Michelle Harris
Alderman, 8th Ward



City of Chicago



O2014-4235

Office of the City Clerk

Document Tracking Sheet

| | |
|---------------------------------|--|
| Meeting Date: | 5/28/2014 |
| Sponsor(s): | Moreno (1) |
| Type: | Ordinance |
| Title: | Amendment of Section 4-60-022 of Municipal Code to allow additional alcoholic liquor licenses on portion(s) of W Chicago Ave |
| Committee(s) Assignment: | Committee on License and Consumer Protection |

ORDINANCE

BE IT ORDAINED BY THE CITY COUNCIL OF THE CITY OF CHICAGO:

SECTION 1. Section 4-60-022 of the Municipal Code of Chicago is hereby amended by deleting the language struck through, as follows:

4-60-022 Restrictions on additional licenses.

Subject to the provisions of subsection 4-60-021(c), no additional license shall be issued for the sale of alcoholic liquor, for consumption on the premises within the following areas:

(Omitted text is unaffected by this ordinance)

~~(1.2) On Chicago Avenue, from Ashland Avenue to Wood Street.~~

(Omitted text is unaffected by this ordinance)

SECTION 2. This ordinance shall be in force and effect upon passage and approval.

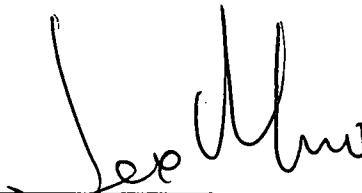

Proco Joe Mofeno
Alderman, 1st Ward



City of Chicago



O2014-4206

Office of the City Clerk

Document Tracking Sheet

| | |
|---------------------------------|--|
| Meeting Date: | 5/28/2014 |
| Sponsor(s): | Graham (29) |
| Type: | Ordinance |
| Title: | Amendment of Municipal Code Section 4-60-023 to disallow additional package goods licenses on portion(s) of N Mobile Ave |
| Committee(s) Assignment: | Committee on License and Consumer Protection |

ORDINANCE

BE IT ORDAINED BY THE CITY COUNCIL OF THE CITY OF CHICAGO:

SECTION 1. The City Council finds that the areas described in Section 2 of this ordinance are adversely affected by the over-concentration of businesses licensed to sell alcoholic liquor within and near the areas.

SECTION 2. Section 4-60-023 of the Municipal Code of Chicago is hereby amended by inserting the underscored language as a new subsection 4-60-023 (29.61), as follows:

4-60-023 Restrictions on additional package goods licenses.

Subject to the provisions of subsection 4-60-021(c), no additional package goods license shall be issued for any premises located within the following areas:

(Omitted text is unaffected by this ordinance)

(29.61) On Mobile Avenue to Narragansett Avenue, and from North Avenue to Bloomingdale Avenue.

(Omitted text is unaffected by this ordinance)

SECTION 3. This ordinance shall be in full force and effect from and after its passage and publication.



Deborah Graham
Alderman, 29th Ward



City of Chicago



O2014-4236

Office of the City Clerk

Document Tracking Sheet

| | |
|---------------------------------|--|
| Meeting Date: | 5/28/2014 |
| Sponsor(s): | Moreno (1) |
| Type: | Ordinance |
| Title: | Exemption from physical barrier requirement for commercial driveway alley access for Ashland 820 LLC |
| Committee(s) Assignment: | Committee on Transportation and Public Way |

BE IT ORDAINED BY THE CITY COUNCIL OF THE CITY OF CHICAGO:

SECTION 1. Per Section 10-20-430 of the Municipal Code of Chicago, the Director of Revenue is hereby authorized and directed to exempt **Ashland 820, LLC** from the provisions requiring barriers as a prerequisite to prohibit alley ingress and egress into **820 N Ashland Avenue**.

SECTION 2. This ordinance shall be in force and take effect from and after its passage and publication.

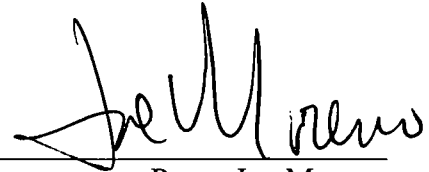
A handwritten signature in black ink, appearing to read "Joe Moreno", written over a horizontal line.

Proco Joe Moreno
Alderman, 1st Ward



City of Chicago



O2014-4216

Office of the City Clerk

Document Tracking Sheet

| | |
|---------------------------------|---|
| Meeting Date: | 5/28/2014 |
| Sponsor(s): | Burns (4) |
| Type: | Ordinance |
| Title: | Exemption from physical barrier requirement for commercial driveway alley access for CAF Construction LLC |
| Committee(s) Assignment: | Committee on Transportation and Public Way |

ORDINANCE

BE IT ORDAINED BY THE CITY COUNCIL OF THE CITY OF CHICAGO:

SECTION 1. Section 10-20-430 of the Municipal Code of Chicago, Commissioner of Transportation is hereby authorized and directed to exempt CAF Construction, LLC on behalf of Owner, Andrew Ahitow from the provisions requiring barriers as a prerequisite to prohibit alley ingress and egress to parking facilities for Premise Address at 5432 South Woodlawn.

SECTION 2. This ordinance shall take effect and be in force from and after its passage and publication.



William D. Burns
Alderman, 4th Ward



City of Chicago



O2014-4218

Office of the City Clerk

Document Tracking Sheet

| | |
|---------------------------------|---|
| Meeting Date: | 5/28/2014 |
| Sponsor(s): | Sawyer (6) |
| Type: | Ordinance |
| Title: | Exemption from physical barrier requirement for commercial driveway alley access for Dedicated Auto |
| Committee(s) Assignment: | Committee on Transportation and Public Way |

COMMITTEE ON TRANSPORTATION AND THE PUBLIC WAY
DRIVEWAY PERMITS

BE IT ORDAINED BY THE CITY COUNCIL OF THE CITY OF CHICAGO

SECTION 1: Section 10-20-430 of the Municipal Code of the City of Chicago, Commissioner of Transportation is hereby authorized and directed to exempt:

DEDICATED AUTO of 7142 S. Vincennes Avenue, from the provisions requiring barriers as a prerequisite to prohibit alley ingress and egress to parking facilities for Premise Address.

SECTION 2: This Ordinance shall take effect and be in force from and after its passage and publication.



RODERICK T. SAWYER, ALDERMAN 6TH Ward

05/28/2014

Handwritten signature or scribble.



City of Chicago



O2014-4209

Office of the City Clerk

Document Tracking Sheet

| | |
|---------------------------------|--|
| Meeting Date: | 5/28/2014 |
| Sponsor(s): | Beale (9) |
| Type: | Ordinance |
| Title: | Exemption from physical barrier requirement for commercial driveway alley access for Little Feathers Performing Arts Child Care Center |
| Committee(s) Assignment: | Committee on Transportation and Public Way |

BE IT ORDAINED BY THE CITY COUNCIL OF THE CITY OF CHICAGO

SECTION: Pursuant of Section 10-20-430 of the Municipal Code of Chicago, Commissioner of Transportation is hereby authorized and directed to exempt Little Feathers Performing Arts Child Care Center at 11255 S. Michigan Ave., from the provisions requiring barriers as prerequisite to prohibit alley ingress and or egress to parking facilities for 11255 S. Michigan Ave.

Section 2. This ordinance shall take effect and be in force from and after its passage and publication.

Alderman Anthony A. Beale

5-28-14
Date



City of Chicago



O2014-4245

Office of the City Clerk

Document Tracking Sheet

| | |
|---------------------------------|---|
| Meeting Date: | 5/28/2014 |
| Sponsor(s): | Pope (10) |
| Type: | Ordinance |
| Title: | Exemption from physical barrier requirement for commercial driveway alley access for T.F. Real Estate (Commercial fast food Restaurant) |
| Committee(s) Assignment: | Committee on Transportation and Public Way |

Referred to:
Committee on Transportation and Public Way

Introduction Date: Page 1
May 28, 2014

TO ALL PROPERTY OWNERS, INGRESS AND EGRESS TO PUBLIC ALLEYS FROM PRIVATE PROPERTY IS PROHIBITED, UNLESS EXEMPTED BY ORDINANCE FROM THE ALDERMAN OF YOUR WARD.

BE IT ORDAINED BY THE CITY COUNCIL OF THE CITY OF CHICAGO.

Section 1. Sections 10-20-430 of the Municipal Code of Chicago, Commissioner of Transportation is hereby authorized and directed to exempt T.F. Real Estate (Commercial fast food restaurant) of 10258 S. Ewing from the provisions requiring barriers as a prerequisite to prohibit alley ingress and egress to parking facilities from premise address.

Section 2. This ordinance shall take effect and be in force from and after its passage and publication.

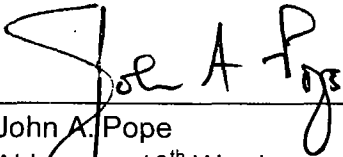

John A. Pope
Alderman, 10th Ward



City of Chicago



O2014-4246

Office of the City Clerk

Document Tracking Sheet

| | |
|---------------------------------|---|
| Meeting Date: | 5/28/2014 |
| Sponsor(s): | Pope (10) |
| Type: | Ordinance |
| Title: | Exemption from physical barrier requirement for commercial driveway alley access for Jump Start Academy-Amazing Friends LLC |
| Committee(s) Assignment: | Committee on Transportation and Public Way |

Referred to:
Committee on Transportation and Public Way

Introduction Date: Page 1
May 28, 2014

TO ALL PROPERTY OWNERS, INGRESS AND EGRESS TO PUBLIC ALLEYS FROM PRIVATE PROPERTY IS PROHIBITED, UNLESS EXEMPTED BY ORDINANCE FROM THE ALDERMAN OF YOUR WARD.

BE IT ORDAINED BY THE CITY COUNCIL OF THE CITY OF CHICAGO.

Section 1. Sections 10-20-430 of the Municipal Code of Chicago, Commissioner of Transportation is hereby authorized and directed to exempt Jump Start Academy – Amazing Friends LLC of 9802 S. Ewing from the provisions requiring barriers as a prerequisite to prohibit alley ingress and egress to parking facilities from premise address.

Section 2. This ordinance shall take effect and be in force from and after its passage and publication.

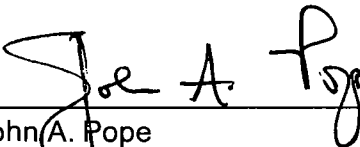

John A. Pope
Alderman, 10th Ward



City of Chicago



O2014-4210

Office of the City Clerk

Document Tracking Sheet

| | |
|---------------------------------|---|
| Meeting Date: | 5/28/2014 |
| Sponsor(s): | Thomas (17) |
| Type: | Ordinance |
| Title: | Exemption from physical barrier requirement for commercial driveway alley access for Jackie Edwards |
| Committee(s) Assignment: | Committee on Transportation and Public Way |

CITY COUNCIL MEETING
April 30, 2014

BE IT ORDAINED BY THE CITY COUNCIL OF THE CITY OF CHICAGO:

- SECTION 1. Pursuant to Section 10-20-430 of the Municipal code of Chicago, the Director of Revenue is hereby authorized and directed to exempt **Jackie Edwards** from the provisions requiring barriers as a prerequisite to prohibit alley ingress and/or egress to parking facilities for **1153 W. 69th St.**
- SECTION 2. This ordinance shall take effect and be in force upon its passage and publication.



Latasha R. Thomas
Alderman, 17th Ward



City of Chicago



O2014-4204

Office of the City Clerk

Document Tracking Sheet

| | |
|---------------------------------|---|
| Meeting Date: | 5/28/2014 |
| Sponsor(s): | Lane (18) |
| Type: | Ordinance |
| Title: | Exemption from physical barrier requirement for commercial driveway alley access for Young Scholars Learning Center |
| Committee(s) Assignment: | Committee on Transportation and Public Way |

ORDINANCE

BE IT ORDAINED BY THE CITY COUNCIL OF THE CITY OF CHICAGO:

SECTION 1: Section 10-20-430 of the Municipal Code of Chicago, the Commissioner of Transportation is hereby authorized and directed to exempt Young Scholars Learning Center, 3800 W. 84th Street, Chicago, IL 60652 from the provisions requiring barriers as a prerequisite to prohibit alley ingress and egress to parking facilities for premise address.

SECTION 2: This ordinance shall take effect and be in force from and after its passage and publication.



Lona Lane
18th Ward Alderman

City Council: May 28, 2014



City of Chicago



O2014-4207

Office of the City Clerk

Document Tracking Sheet

| | |
|---------------------------------|---|
| Meeting Date: | 5/28/2014 |
| Sponsor(s): | Zalewski (23) |
| Type: | Ordinance |
| Title: | Exemption from physical barrier requirement for commercial driveway alley access for Rogelio Richart of Xpress Auto and Tires |
| Committee(s) Assignment: | Committee on Transportation and Public Way |

BE IT ORDAINED BY THE COUNCIL OF THE CITY OF CHICAGO:

SECTIONS 1. Pursuant to Section 10-20-430 of the Municipal Code of Chicago, the Commissioner of Transportation is hereby authorized and directed to exempt Rogelio Richart of Xpress Auto and Tires from the provisions requiring barriers as a prerequisite to prohibit alley ingress and egress to the parking facilities for 3800 W. 55th Street, Chicago, IL. 60632.

SECTION 2. This ordinance shall take effect and be in force from and after its passage and publication.

City Council Meeting
May 28, 2014

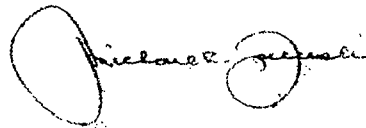
A handwritten signature in black ink, appearing to read "Michael R. Zalewski". The signature is written in a cursive style with a large, looped initial "M".

Michael R. Zalewski
Alderman, 23rd Ward



City of Chicago



O2014-4219

Office of the City Clerk

Document Tracking Sheet

| | |
|---------------------------------|--|
| Meeting Date: | 5/28/2014 |
| Sponsor(s): | Solis (25) |
| Type: | Ordinance |
| Title: | Exemption from physical barrier requirement for commercial driveway alley access for J&M Auto Repair |
| Committee(s) Assignment: | Committee on Transportation and Public Way |

May 28, 2014

BE IT ORDAINED BY THE CITY COUNCIL OF THE CITY OF CHICAGO:

SECTION 1. Section 10-20-430 of the Municipal Code of Chicago, Commissioner of Transportation is hereby authorized and directed to exempt:

Property Owner: Jose Orozco Merced Vieyra

Business Type: Auto Repair Shop

Business Name: J&M Auto Repair

Address: 2560 South Blue Island Chicago, IL 60608

from the provisions requiring barriers as a prerequisite to prohibit alley ingress and egress to parking facilities for Premise Address.

SECTION 2. This ordinance shall take effect and be in force from and after its passage and publication.

Alderman



Date

5/28/14



City of Chicago



O2014-4222

Office of the City Clerk

Document Tracking Sheet

| | |
|---------------------------------|---|
| Meeting Date: | 5/28/2014 |
| Sponsor(s): | Solis (25) |
| Type: | Ordinance |
| Title: | Exemption from physical barrier requirement for commercial driveway alley access for Atotonilco |
| Committee(s) Assignment: | Committee on Transportation and Public Way |

May 28, 2014

BE IT ORDAINED BY THE CITY COUNCIL OF THE CITY OF CHICAGO:

SECTION 1. Section 10-20-430 of the Municipal Code of Chicago, Commissioner of Transportation is hereby authorized and directed to exempt:

Property Owner: Oscar Munoz

Business Type: Restaurant

Business Name: Atotonilco

Address: 1633 South Blue Island Chicago, IL 60608

from the provisions requiring barriers as a prerequisite to prohibit alley ingress and egress to parking facilities for Premise Address.

SECTION 2. This ordinance shall take effect and be in force from and after its passage and publication.

Alderman

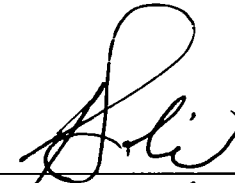

Date

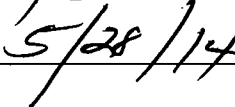



City of Chicago



O2014-4241

Office of the City Clerk

Document Tracking Sheet

| | |
|---------------------------------|---|
| Meeting Date: | 5/28/2014 |
| Sponsor(s): | Burnett (27) |
| Type: | Ordinance |
| Title: | Exemption from physical barrier requirement for commercial driveway alley access for Phil Denny Peppercorn 1229 LLC |
| Committee(s) Assignment: | Committee on Transportation and Public Way |

Driveway Permits

BE IT ORDAINED BY THE CITY COUNCIL OF THE CITY OF CHICAGO

SECTION 1: Section 10-20-430 of the Municipal Code of Chicago, Commissioner of Transportation is hereby authorized and directed to exempt

Phil Denny
Peppercorn 1229, LLC of **1229 W. Washington**, from the provisions requiring barriers as prerequisite to prohibit alley ingress and egress to parking facilities for Premise Address.

SECTION 2: This ordinance shall take effect and be in force from and after its passage and publication.

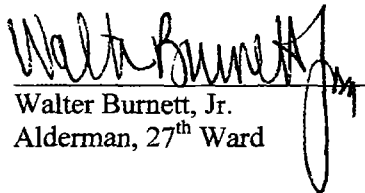
Walter Burnett, Jr.
Alderman, 27th Ward



City of Chicago



O2014-4243

Office of the City Clerk

Document Tracking Sheet

| | |
|---------------------------------|---|
| Meeting Date: | 5/28/2014 |
| Sponsor(s): | Burnett (27) |
| Type: | Ordinance |
| Title: | Exemption from physical barrier requirement for commercial driveway alley access for Penelope Vamava Learn Chartered School Network |
| Committee(s) Assignment: | Committee on Transportation and Public Way |

Driveway Permits

BE IT ORDAINED BY THE CITY COUNCIL OF THE CITY OF CHICAGO

SECTION 1: Section 10-20-430 of the Municipal Code of Chicago, Commissioner of

Transportation is hereby authorized and directed to exempt

Penelope Vamava
Learn Chartered School Network of **3000 W. Fulton**, from the

provisions requiring barriers as prerequisite to prohibit alley ingress

and egress to parking facilities for Premise Address.

SECTION 2: This ordinance shall take effect and be in force from and after its

passage and publication.

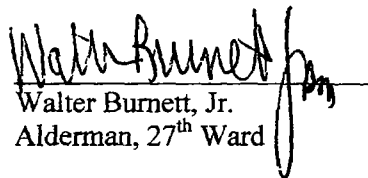
Walter Burnett, Jr.
Alderman, 27th Ward



City of Chicago



O2014-4155

Office of the City Clerk

Document Tracking Sheet

| | |
|---------------------------------|--|
| Meeting Date: | 5/28/2014 |
| Sponsor(s): | Reboyras (30) |
| Type: | Ordinance |
| Title: | Exemption from physical barrier requirement for commercial driveway alley access for Yakov Plotkim |
| Committee(s) Assignment: | Committee on Transportation and Public Way |

BE IT ORDAINED BY THE CITY COUNCIL OF THE CITY OF CHICAGO:

SECTION 1. Section 10-20-430 of the Municipal Code of Chicago, the Director of Revenue is hereby authorized and directed to exempt:

**Mr. Yakov Plotkim
3445 North Milwaukee Avenue**

from the provisions requiring barriers as a prerequisite to prohibit alley ingress and egress to parking facilities for premise(s) address.

SECTION 2. This ordinance shall take effect and be in force from and after its passage and due publication.

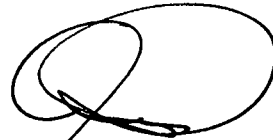

Ariel E. Reboyras
30th Ward Alderman



City of Chicago



O2014-4228

Office of the City Clerk

Document Tracking Sheet

| | |
|---------------------------------|--|
| Meeting Date: | 5/28/2014 |
| Sponsor(s): | Waguespack (32) |
| Type: | Ordinance |
| Title: | Exemption from physical barrier requirement for commercial driveway alley access for Clybourn Construction LLC |
| Committee(s) Assignment: | Committee on Transportation and Public Way |

BE IT ORDAINED BY THE CITY COUNCIL OF THE CITY OF CHICAGO:

SECTION 1. Pursuant to Section 10-20-430 of the Municipal Code of Chicago, the Director of the Department of Revenue is hereby authorized and directed to exempt Clybourn Construction LLC at 2440-42 N Clybourn from requiring barriers as a prerequisite to prohibit alley ingress and egress.

SECTION 2. This ordinance shall take effect and be in force upon its passage and publication.



Scott Waguespack
Alderman, 32nd Ward



City of Chicago



O2014-4229

Office of the City Clerk

Document Tracking Sheet

| | |
|---------------------------------|--|
| Meeting Date: | 5/28/2014 |
| Sponsor(s): | Waguespack (32) |
| Type: | Ordinance |
| Title: | Exemption from physical barrier requirement for commercial driveway alley access for Clybourn Ventures LLC |
| Committee(s) Assignment: | Committee on Transportation and Public Way |

BE IT ORDAINED BY THE CITY COUNCIL OF THE CITY OF CHICAGO:

SECTION 1. Pursuant to Section 10-20-430 of the Municipal Code of Chicago, the Director of the Department of Revenue is hereby authorized and directed to exempt Clybourn Ventures LLC at 2464 N Clybourn from requiring barriers as a prerequisite to prohibit alley ingress and egress.

SECTION 2. This ordinance shall take effect and be in force upon its passage and publication.

Scott Waguespack
Alderman, 32nd Ward



City of Chicago



O2014-4213

Office of the City Clerk

Document Tracking Sheet

Meeting Date: 5/28/2014

Sponsor(s): Sposato (36)

Type: Ordinance

Title: Exemption from physical barrier requirement for commercial driveway alley access for Dando Repair Resale and Restoration

Committee(s) Assignment: Committee on Transportation and Public Way

CITY COUNCIL: May 28, 2014

BE IT ORDAINED BY THE CITY COUNCIL OF CHICAGO:

SECTION 1. Pursuant to Section 10-20-430 of the Municipal Code of Chicago, the Commissioner of Transportation is hereby authorized and directed to exempt **Dando Repair Resale and Restoration, 6957-6959 W. Grand Avenue**, from the provisions requiring barriers as a prerequisite to prohibit alley ingress and egress to parking facilities for Premise Address.

SECTION 2. This ordinance shall take effect and be in force from and after its passage and publication.

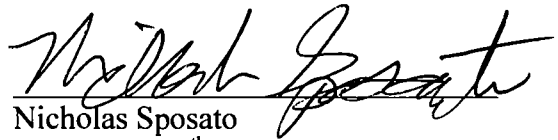

Nicholas Sposato
Alderman, 36th Ward



City of Chicago



O2014-4239

Office of the City Clerk

Document Tracking Sheet

| | |
|---------------------------------|---|
| Meeting Date: | 5/28/2014 |
| Sponsor(s): | Reilly (42) |
| Type: | Ordinance |
| Title: | Exemption from physical barrier requirement for commercial driveway alley access for Wells Street Development LLC |
| Committee(s) Assignment: | Committee on Transportation and Public Way |

Committee on Transportation and Public Way
City Council Meeting May 28, 2014
Alderman Brendan Reilly, 42nd Ward
Alley Access Ordinance

BE IT ORDAINED BY THE CITY COUNCIL OF THE CITY OF CHICAGO:

SECTION 1. Pursuant to Section 10-20-430 of the Municipal Code of Chicago, the Commissioner of Transportation is hereby authorized and directed to exempt Wells Street Development LLC from the provisions requiring barriers as a prerequisite to prohibit alley ingress and/or egress 707 North Wells Street.

SECTION 2. This ordinance shall take effect and be in force upon its passage and publication.



Brendan Reilly
Alderman, 42nd Ward

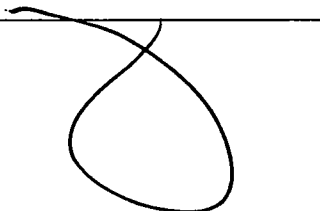



City of Chicago



O2014-4240

Office of the City Clerk

Document Tracking Sheet

| | |
|---------------------------------|---|
| Meeting Date: | 5/28/2014 |
| Sponsor(s): | Reilly (42) |
| Type: | Ordinance |
| Title: | Exemption from physical barrier requirement for commercial driveway alley access for Eleven Hundred LLC |
| Committee(s) Assignment: | Committee on Transportation and Public Way |

Committee on Transportation and Public Way
City Council Meeting May 28, 2014
Alderman Brendan Reilly, 42nd Ward
Alley Access Ordinance

BE IT ORDAINED BY THE CITY COUNCIL OF THE CITY OF CHICAGO:

SECTION 1. Pursuant to Section 10-20-430 of the Municipal Code of Chicago, the Commissioner of Transportation is hereby authorized and directed to exempt Eleven Hundred LLC from the provisions requiring barriers as a prerequisite to prohibit alley ingress and/or egress 1100 North State Street.

SECTION 2. This ordinance shall take effect and be in force upon its passage and publication.



Brendan Reilly
Alderman, 42nd Ward

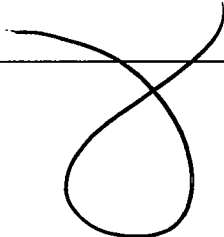



City of Chicago



O2014-4242

Office of the City Clerk

Document Tracking Sheet

| | |
|---------------------------------|---|
| Meeting Date: | 5/28/2014 |
| Sponsor(s): | Reilly (42) |
| Type: | Ordinance |
| Title: | Exemption from physical barrier requirement for commercial driveway alley access for 1221 N LaSalle LLC |
| Committee(s) Assignment: | Committee on Transportation and Public Way |

Committee on Transportation and Public Way
City Council Meeting May 28, 2014
Alderman Brendan Reilly, 42nd Ward
Alley Access Ordinance

BE IT ORDAINED BY THE CITY COUNCIL OF THE CITY OF CHICAGO:

SECTION 1. Pursuant to Section 10-20-430 of the Municipal Code of Chicago, the Commissioner of Transportation is hereby authorized and directed to exempt 1221 N. LaSalle LLC from the provisions requiring barriers as a prerequisite to prohibit alley ingress and/or egress 1221 North LaSalle.

SECTION 2. This ordinance shall take effect and be in force upon its passage and publication.



Brendan Reilly
Alderman, 42nd Ward

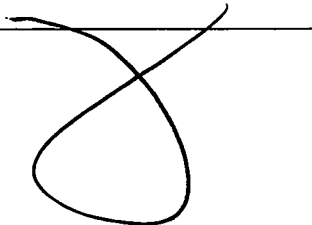



City of Chicago



O2014-4238

Office of the City Clerk

Document Tracking Sheet

| | |
|---------------------------------|---|
| Meeting Date: | 5/28/2014 |
| Sponsor(s): | Tunney (44) |
| Type: | Ordinance |
| Title: | Exemption from physical barrier requirement for commercial driveway alley access for Chicago Cubs Baseball Club LLC |
| Committee(s) Assignment: | Committee on Transportation and Public Way |

trans + public way

City Council Meeting
May 28, 2014

BE IT ORDAINED BY THE CITY COUNCIL OF THE CITY OF CHICAGO:

SECTION 1. Section 10-20-430 of the Municipal Code of Chicago, the Director of Revenue is hereby authorized and directed to exempt:

Chicago Cubs Baseball Club LLC located at 1152 West Eddy Street, from the provisions requiring barriers as a prerequisite to prohibit alley ingress and egress to parking facilities.

SECTION 2. This ordinance shall take effect and be in force from and after its passage and publication.

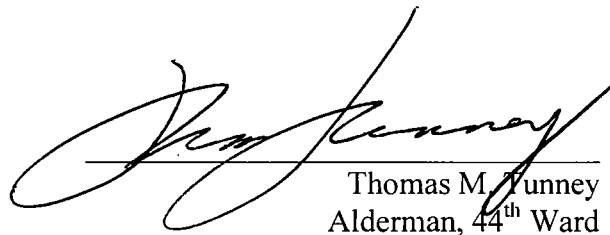
Thomas M. Tunney
Alderman, 44th Ward



City of Chicago



O2014-4244

Office of the City Clerk

Document Tracking Sheet

| | |
|---------------------------------|--|
| Meeting Date: | 5/28/2014 |
| Sponsor(s): | Pawar (47) |
| Type: | Ordinance |
| Title: | Exemption from physical barrier requirement for commercial driveway alley access for Maya Motors, Inc. |
| Committee(s) Assignment: | Committee on Transportation and Public Way |

BE IT ORDAINED BY THE CITY COUNCIL OF THE CITY OF CHICAGO:

SECTION 1. Pursuant to Section 10-20-430 of the Municipal Code of Chicago, the Director of the Department of Revenue is hereby authorized and directed to exempt **Maya Motors Inc.** at **4620 N Western Ave** from requiring barriers as a prerequisite to prohibit alley ingress and egress to parking facilities for premise address.

SECTION 2. This ordinance shall take effect and be in force upon its passage and publication.

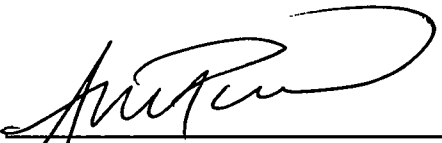

Arneja Pawar
Alderman, Ward 47



CITY COUNCIL

CITY OF CHICAGO

COUNCIL CHAMBER

CITY HALL, ROOM 200
121 NORTH LA SALLE STREET
CHICAGO, ILLINOIS 60602
TELEPHONE 312-744-0446

COMMITTEE MEMBERSHIPS

COMMITTEES, RULES & ETHICS

ECONOMIC, CAPITAL AND TECHNOLOGY DEPARTMENT

PUBLIC SAFETY

SPECIAL EVENTS, CULTURAL AFFAIRS AND RECREATION

ZONING, LANDMARKS AND BUILDING STANDARDS

AMEYA PAWAR, MPA, M.Sc.

ALDERMAN, 47TH WARD
4243 NORTH LINCOLN AVENUE
CHICAGO, ILLINOIS 60618
TELEPHONE: 773-868-4747
FAX: 773-549-4757

May 7, 2014

Honorable Anthony Beale
Chairman, Committee on Transportation and Public Way
121 N LaSalle Street, Room 305
Chicago, IL 60602

Re: Alley Access at **4620 N Western Ave**

Dear Chairman Beale:

I am respectfully requesting a commissioner's authority letter exempting **Maya Motors Inc.** from being required to place barriers as a prerequisite to prohibit alley ingress and egress to parking facilities at their property at **4620 N Western Ave.** Please issue the letter once an ordinance to this effect has been introduced to the City Council on **May 28, 2014.**

Please contact my office with any questions.

Sincerely,

Alderman, Ward 47



City of Chicago



O2014-4282

Office of the City Clerk

Document Tracking Sheet

| | |
|---------------------------------|--|
| Meeting Date: | 5/28/2014 |
| Sponsor(s): | Moreno (1) |
| Type: | Ordinance |
| Title: | Awning(s) for Artemio's Bakery No. 2 |
| Committee(s) Assignment: | Committee on Transportation and Public Way |

ORDINANCE
ARTEMIO'S BAKERY #2
Acct. No. 6600 - 3
Permit No. 1112961

Be It Ordained by the City Council of the City of Chicago:

SECTION 1. Permission and authority are hereby given and granted to ARTEMIO'S BAKERY #2, upon the terms and subject to the conditions of this ordinance to maintain and use, as now constructed, one (1) Awning(s) projecting over the public right-of-way adjacent to its premises known as 1443 N. Milwaukee Ave..

Said Awning(s) at N MILWAUKEE AVE measure(s):

One (1) at twenty (20) feet in length, and four (4) feet in width for a total of eighty (80) square feet.

The location of said privilege shall be as shown on prints kept on file with the Department of Business Affairs and Consumer Protection and the Office of the City Clerk.

Said privilege shall be constructed in accordance with plans and specifications approved by the Zoning Department - Signs.

This grant of privilege in the public way shall be subject to the provisions of Section 10-28-015 and all other required provisions of the Municipal Code of Chicago.

The grantee shall pay to the City of Chicago as compensation for the privilege #1112961 herein granted the sum of fifty (\$50.00) per annum in advance.

A 25% penalty will be added for payments received after due date.

The permit holder agrees to hold the City of Chicago harmless for any damage, relocation or replacement costs associated with damage, relocation or removal of private property caused by the City performing work in the public way.

Authority herein given and granted for a period of five (5) years from and after 04/22/2014.

Alderman _____

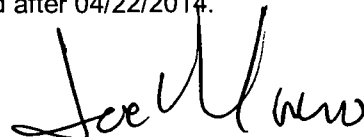

Proco Joe Moreno 1st Ward

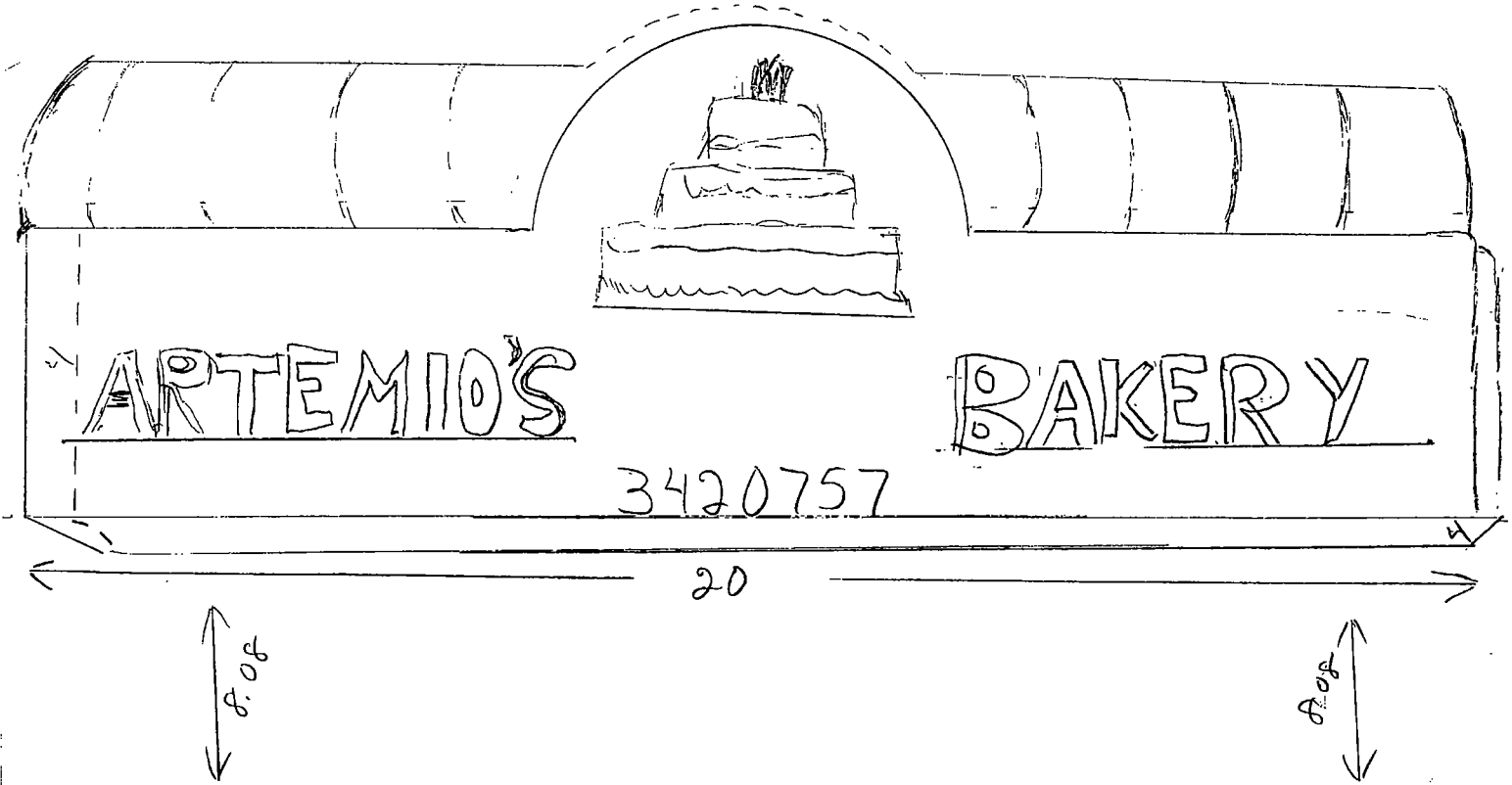



05/28/2014

Alderman **Proco Joe Moreno**
Ward # **01**
City of Chicago
City Hall, Room **300**
121 North LaSalle Street
Chicago, Illinois 60602

Re: An ordinance to use and maintain a portion of the public right-of-way for **one (1) awning(s)** for **ARTEMIO'S BAKERY #2**, adjacent to the premises known as **1443 N. Milwaukee Ave.**.

Dear Alderman **Proco Joe Moreno**:

The applicant referenced above has requested the use of the public right-of-way for a **awning(s)**. An ordinance has been prepared by the Department of Business Affairs and Consumer Protection – Small Business Center - Public Way Use Unit for presentation to the City Council. Because this request was made for properties located in your ward, as approved by you as per the attached, I respectfully request that you introduce the attached ordinance at the next City Council meeting.

If you have any questions regarding this ordinance, please contact Anthony Bertuca at (312) 744-5506.

Department of Business Affairs and Consumer Protection



City of Chicago



O2014-4288

Office of the City Clerk

Document Tracking Sheet

| | |
|---------------------------------|--|
| Meeting Date: | 5/28/2014 |
| Sponsor(s): | Moreno (1) |
| Type: | Ordinance |
| Title: | Awning(s) for Delta Animal Hospital |
| Committee(s) Assignment: | Committee on Transportation and Public Way |

ORDINANCE
DELTA ANIMAL HOSPITAL
Acct. No. 24952 - 1
Permit No. 1113096

Be It Ordained by the City Council of the City of Chicago:

SECTION 1. Permission and authority are hereby given and granted to DELTA ANIMAL HOSPITAL, upon the terms and subject to the conditions of this ordinance to maintain and use, as now constructed, one (1) Awning(s) projecting over the public right-of-way adjacent to its premises known as 2105 W. Chicago Ave..

Said Awning(s) at W. CHICAGO AVE. measure(s):

One (1) at fifteen point five eight (15.58) feet in length, and four (4) feet in width for a total of sixty-two point three two (62.32) square feet.

The location of said privilege shall be as shown on prints kept on file with the Department of Business Affairs and Consumer Protection and the Office of the City Clerk.

Said privilege shall be constructed in accordance with plans and specifications approved by the Zoning Department - Signs.

This grant of privilege in the public way shall be subject to the provisions of Section 10-28-015 and all other required provisions of the Municipal Code of Chicago.

The grantee shall pay to the City of Chicago as compensation for the privilege #1113096 herein granted the sum of fifty (\$50.00) per annum in advance.

A 25% penalty will be added for payments received after due date.

The permit holder agrees to hold the City of Chicago harmless for any damage, relocation or replacement costs associated with damage, relocation or removal of private property caused by the City performing work in the public way.

Authority herein given and granted for a period of five (5) years from and after 05/13/2014.

Alderman _____ 

Proco Joe Moreno 1st Ward

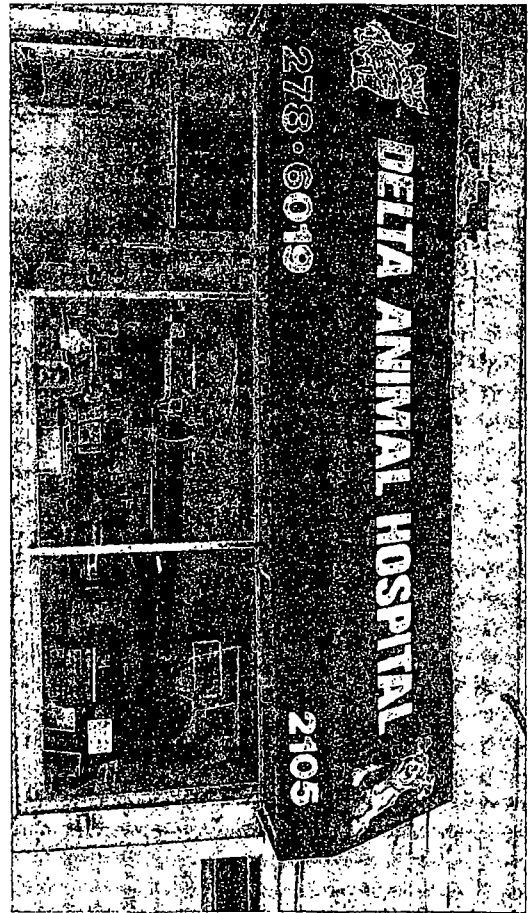



05/28/2014

Alderman **Proco Joe Moreno**
Ward # **01**
City of Chicago
City Hall, Room **300**
121 North LaSalle Street
Chicago, Illinois 60602

Re: An ordinance to use and maintain a portion of the public right-of-way for **one (1) awning(s)** for **DELTA ANIMAL HOSPITAL**, adjacent to the premises known as **2105 W. Chicago Ave.**.

Dear Alderman **Proco Joe Moreno**:

The applicant referenced above has requested the use of the public right-of-way for a **awning(s)**. An ordinance has been prepared by the Department of Business Affairs and Consumer Protection – Small Business Center - Public Way Use Unit for presentation to the City Council. Because this request was made for properties located in your ward, as approved by you as per the attached, I respectfully request that you introduce the attached ordinance at the next City Council meeting.

If you have any questions regarding this ordinance, please contact Anthony Bertuca at (312) 744-5506.

Department of Business Affairs and Consumer Protection



City of Chicago



O2014-4290

Office of the City Clerk

Document Tracking Sheet

| | |
|---------------------------------|--|
| Meeting Date: | 5/28/2014 |
| Sponsor(s): | Moreno (1) |
| Type: | Ordinance |
| Title: | Awning(s) for Gardner School, The |
| Committee(s) Assignment: | Committee on Transportation and Public Way |

ORDINANCE
THE GARDNER SCHOOL
Acct. No. 384649 - 1
Permit No. 1108552

Be It Ordained by the City Council of the City of Chicago:

SECTION 1. Permission and authority are hereby given and granted to THE GARDNER SCHOOL, upon the terms and subject to the conditions of this ordinance to construct, install, maintain and use five (5) Awning(s) projecting over the public right-of-way adjacent to its premises known as 1612 W. North Ave..

Said Awning(s) at North Avenue measure(s):

Three (3) at thirteen point three three (13.33) feet in length, and three (3) feet in width for a total of one hundred nineteen point nine seven (119.97) square feet.

Said Awning(s) at Marshfield measure(s):

Two (2) at thirteen point three three (13.33) feet in length, and three (3) feet in width for a total of seventy-nine point nine eight (79.98) square feet.

The location of said privilege shall be as shown on prints kept on file with the Department of Business Affairs and Consumer Protection and the Office of the City Clerk.

Said privilege shall be constructed in accordance with plans and specifications approved by the Zoning Department - Signs.

This grant of privilege in the public way shall be subject to the provisions of Section 10-28-015 and all other required provisions of the Municipal Code of Chicago.

The grantee shall pay to the City of Chicago as compensation for the privilege #1108552 herein granted the sum of one hundred seventy-five (\$175.00) per annum in advance.

A 25% penalty will be added for payments received after due date.

The permit holder agrees to hold the City of Chicago harmless for any damage, relocation or replacement costs associated with damage, relocation or removal of private property caused by the City performing work in the public way.

Authority herein given and granted for a period of five (5) years from and after Date of Passage.

Alderman _____ 

Proco Joe Moreno 1st Ward

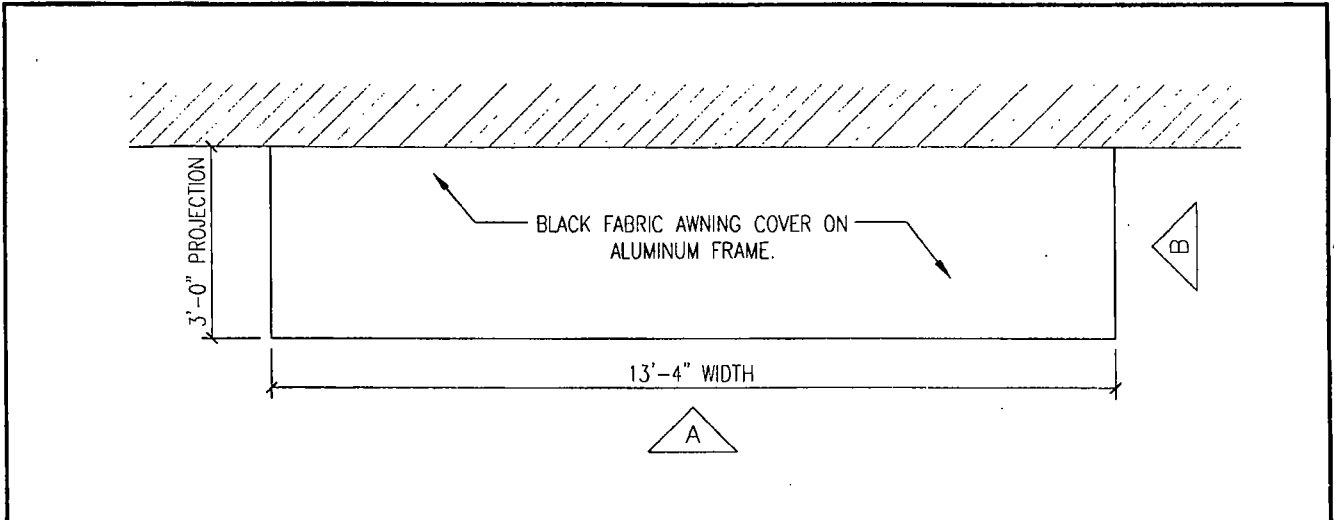

01 AWNING PLAN
SCALE 3/8"=1'-0"

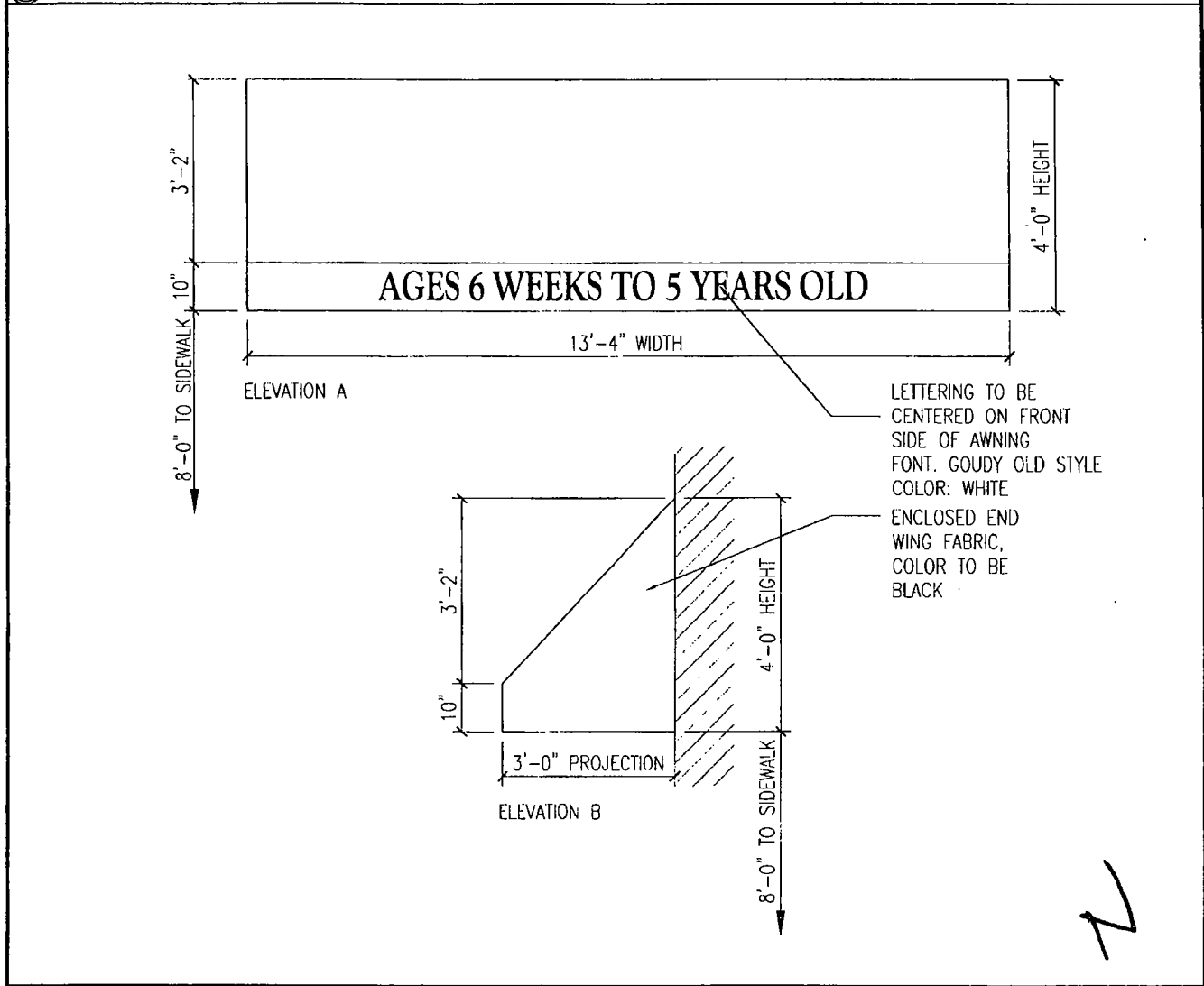

ARCHITECT:
NORR
ARCHITECTS PLANNERS
323 N. LaSalle St., Suite 703 Chicago, IL 60610
312.467.4400 / 312.467.4411 www.norr.com

PROJECT:
THE GARDNER SCHOOL
1612 NORTH AVENUE
CHICAGO, ILLINOIS 60622

| REVISIONS | | |
|-----------|---------|--------------------|
| # | Date | Issue |
| 01 | 6/29/13 | Awning Application |
| | | |
| | | |

SHEET TITLE
A003
AWNING DRAWINGS



05/28/2014

Alderman **Proco Joe Moreno**
Ward # **01**
City of Chicago
City Hall, Room **300**
121 North LaSalle Street
Chicago, Illinois 60602

Re: An ordinance to use and maintain a portion of the public right-of-way for **five (5) awning(s)** for **THE GARDNER SCHOOL**, adjacent to the premises known as **1612 W. North Ave.**.

Dear Alderman **Proco Joe Moreno**:

The applicant referenced above has requested the use of the public right-of-way for a **awning(s)**. An ordinance has been prepared by the Department of Business Affairs and Consumer Protection – Small Business Center - Public Way Use Unit for presentation to the City Council. Because this request was made for properties located in your ward, as approved by you as per the attached, I respectfully request that you introduce the attached ordinance at the next City Council meeting.

If you have any questions regarding this ordinance, please contact Anthony Bertuca at (312) 744-5506.

Department of Business Affairs and Consumer Protection



City of Chicago



O2014-4293

Office of the City Clerk

Document Tracking Sheet

| | |
|---------------------------------|--|
| Meeting Date: | 5/28/2014 |
| Sponsor(s): | Moreno (1) |
| Type: | Ordinance |
| Title: | Awning(s) for Janik's Cafe |
| Committee(s) Assignment: | Committee on Transportation and Public Way |

ORDINANCE
JANIK'S CAFE
Acct. No. 263712 - 1
Permit No. 1112951

Be It Ordained by the City Council of the City of Chicago:

SECTION 1. Permission and authority are hereby given and granted to JANIK'S CAFE, upon the terms and subject to the conditions of this ordinance to maintain and use, as now constructed, one (1) Awning(s) projecting over the public right-of-way adjacent to its premises known as 2011 W. Division St..

Said Awning(s) at W. Division Street measure(s):

One (1) at twenty-one point three three (21.33) feet in length, and four (4) feet in width for a total of eighty-five point three two (85.32) square feet.

The location of said privilege shall be as shown on prints kept on file with the Department of Business Affairs and Consumer Protection and the Office of the City Clerk.

Said privilege shall be constructed in accordance with plans and specifications approved by the Zoning Department - Signs.

This grant of privilege in the public way shall be subject to the provisions of Section 10-28-015 and all other required provisions of the Municipal Code of Chicago.

The grantee shall pay to the City of Chicago as compensation for the privilege #1112951 herein granted the sum of fifty (\$50.00) per annum in advance.

A 25% penalty will be added for payments received after due date.

The permit holder agrees to hold the City of Chicago harmless for any damage, relocation or replacement costs associated with damage, relocation or removal of private property caused by the City performing work in the public way.

Authority herein given and granted for a period of five (5) years from and after 05/24/2014.

Alderman _____ 

Proco Joe Moreno 1st Ward

Janik's Café
2011 W. Division St.
Chicago, IL. 60622
773.276.7930

Canopy Drawing Includes Front and Side View

Canopy is 21 ft long and 4 Ft high and 2 ft. wide.
To be secured to the masonry front at 9 ft. 5 in.
above the public way.

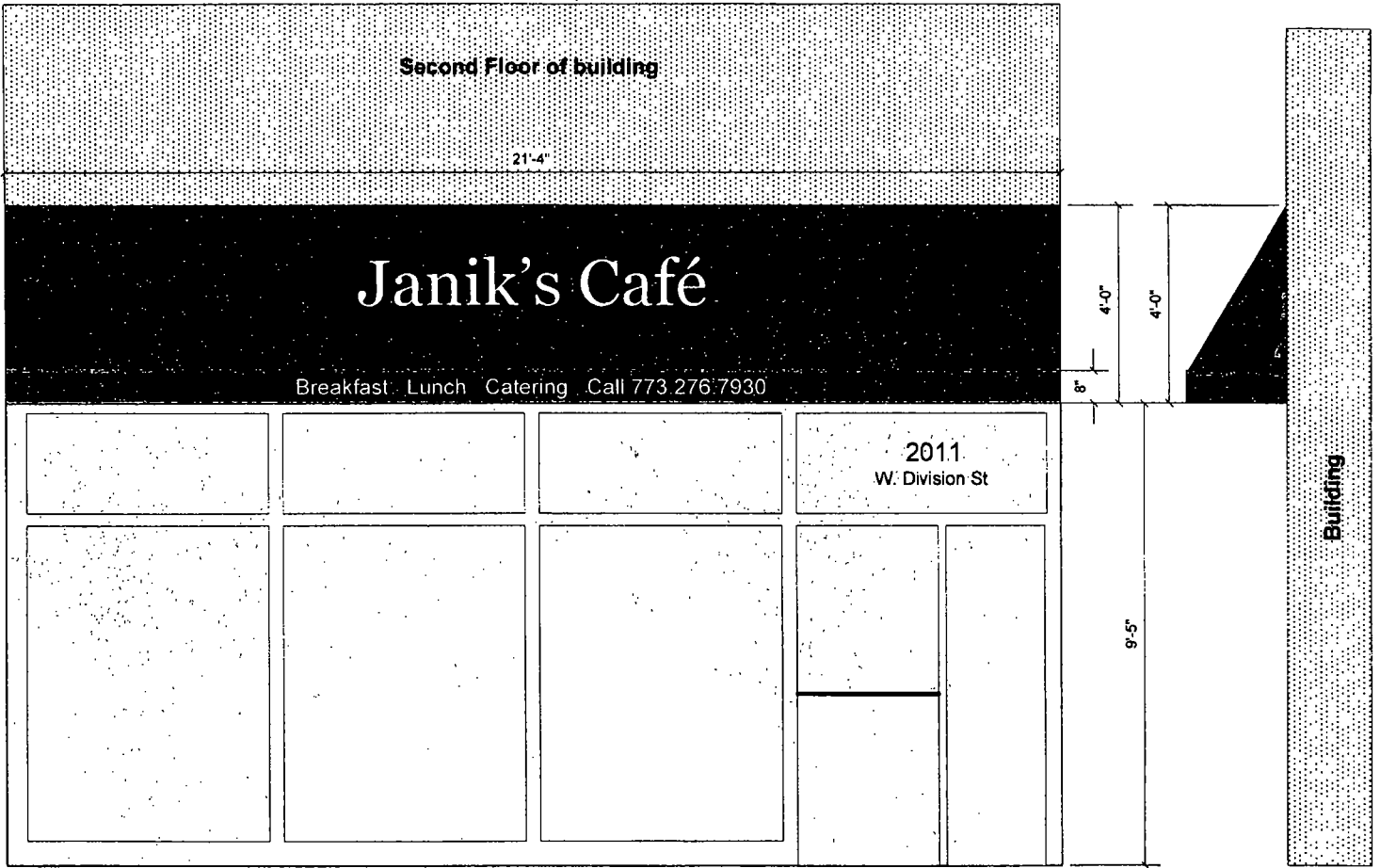

Front View

Side View



05/28/2014

Alderman **Proco Joe Moreno**
Ward # **01**
City of Chicago
City Hall, Room **300**
121 North LaSalle Street
Chicago, Illinois 60602

Re: An ordinance to use and maintain a portion of the public right-of-way for **one (1) awning(s)** for **JANIK'S CAFE**, adjacent to the premises known as **2011 W. Division St.**

Dear Alderman **Proco Joe Moreno**:

The applicant referenced above has requested the use of the public right-of-way for a **awning(s)**. An ordinance has been prepared by the Department of Business Affairs and Consumer Protection – Small Business Center - Public Way Use Unit for presentation to the City Council. Because this request was made for properties located in your ward, as approved by you as per the attached, I respectfully request that you introduce the attached ordinance at the next City Council meeting.

If you have any questions regarding this ordinance, please contact Anthony Bertuca at (312) 744-5506.

Department of Business Affairs and Consumer Protection



City of Chicago



O2014-4300

Office of the City Clerk

Document Tracking Sheet

| | |
|---------------------------------|--|
| Meeting Date: | 5/28/2014 |
| Sponsor(s): | Moreno (1) |
| Type: | Ordinance |
| Title: | Awning(s) for Kasia's |
| Committee(s) Assignment: | Committee on Transportation and Public Way |

ORDINANCE
KASIA'S
Acct. No. 271902 - 1
Permit No. 1113088

Be It Ordained by the City Council of the City of Chicago:

SECTION 1. Permission and authority are hereby given and granted to KASIA'S, upon the terms and subject to the conditions of this ordinance to maintain and use, as now constructed, two (2) Awning(s) projecting over the public right-of-way adjacent to its premises known as 2101 W. Chicago Ave..

Said Awning(s) at W. CHICAGO measure(s):

One (1) at fourteen (14) feet in length, and three (3) feet in width for a total of forty-two (42) square feet.

Said Awning(s) at N. HOYNE measure(s):

One (1) at seven (7) feet in length, and three (3) feet in width for a total of twenty-one (21) square feet.

The location of said privilege shall be as shown on prints kept on file with the Department of Business Affairs and Consumer Protection and the Office of the City Clerk.

Said privilege shall be constructed in accordance with plans and specifications approved by the Zoning Department - Signs.

This grant of privilege in the public way shall be subject to the provisions of Section 10-28-015 and all other required provisions of the Municipal Code of Chicago.

The grantee shall pay to the City of Chicago as compensation for the privilege #1113088 herein granted the sum of one hundred (\$100.00) per annum in advance.

A 25% penalty will be added for payments received after due date.

The permit holder agrees to hold the City of Chicago harmless for any damage, relocation or replacement costs associated with damage, relocation or removal of private property caused by the City performing work in the public way.

Authority herein given and granted for a period of five (5) years from and after 03/18/2014.

Alderman _____



Proco Joe Moreno 1st Ward

W Chicago Ave

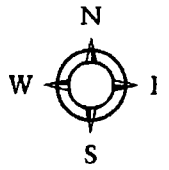
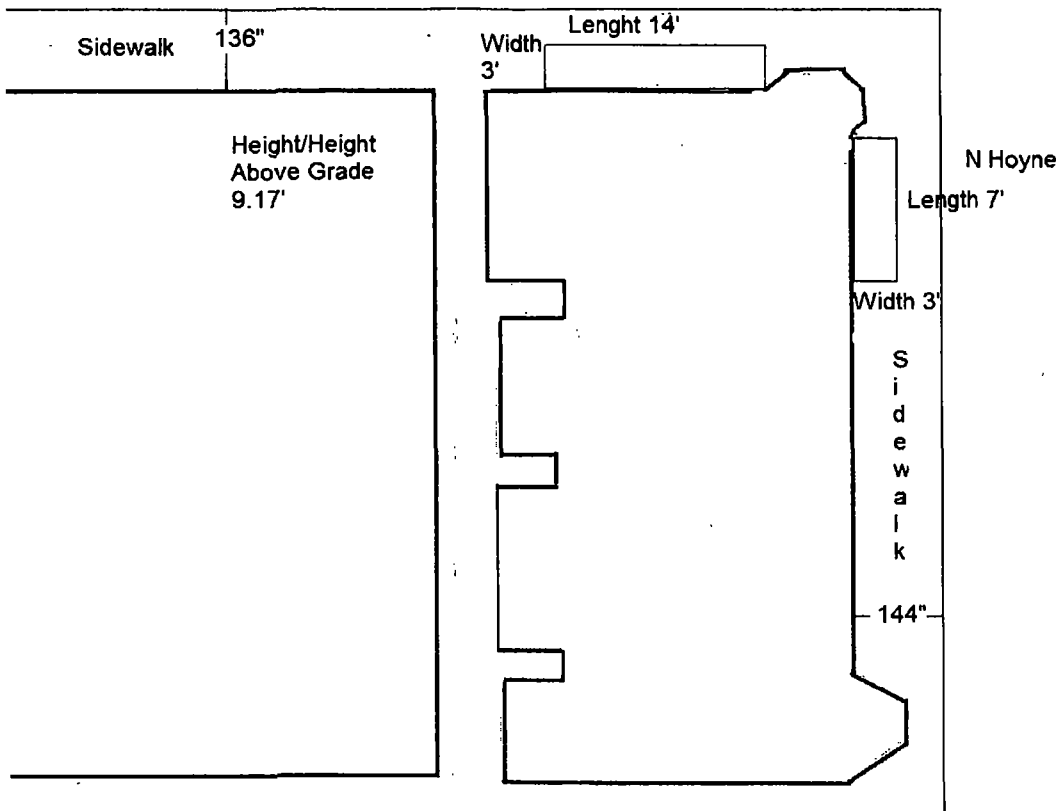



05/28/2014

Alderman **Proco Joe Moreno**
Ward # **01**
City of Chicago
City Hall, Room **300**
121 North LaSalle Street
Chicago, Illinois 60602

Re: An ordinance to use and maintain a portion of the public right-of-way for **two (2) awning(s)** for **KASIA'S**, adjacent to the premises known as **2101 W. Chicago Ave.**.

Dear Alderman **Proco Joe Moreno**:

The applicant referenced above has requested the use of the public right-of-way for a **awning(s)**. An ordinance has been prepared by the Department of Business Affairs and Consumer Protection – Small Business Center - Public Way Use Unit for presentation to the City Council. Because this request was made for properties located in your ward, as approved by you as per the attached, I respectfully request that you introduce the attached ordinance at the next City Council meeting.

If you have any questions regarding this ordinance, please contact Anthony Bertuca at (312) 744-5506.

Department of Business Affairs and Consumer Protection



City of Chicago



O2014-4307

Office of the City Clerk

Document Tracking Sheet

| | |
|---------------------------------|--|
| Meeting Date: | 5/28/2014 |
| Sponsor(s): | Moreno (1) |
| Type: | Ordinance |
| Title: | Awning(s) for Margie's Candies |
| Committee(s) Assignment: | Committee on Transportation and Public Way |

ORDINANCE
MARGIE'S CANDIES
Acct. No. 295980 - 2
Permit No. 1108330

Be It Ordained by the City Council of the City of Chicago:

SECTION 1. Permission and authority are hereby given and granted to MARGIE'S CANDIES, upon the terms and subject to the conditions of this ordinance to maintain and use, as now constructed, two (2) Awning(s) projecting over the public right-of-way adjacent to its premises known as 1960 N. Western Ave..

Said Awning(s) at Western measure(s):

One (1) at fourteen (14) feet in length, and four (4) feet in width for a total of fifty-six (56) square feet.

One (1) at fifteen (15) feet in length, and four (4) feet in width for a total of sixty (60) square feet.

The location of said privilege shall be as shown on prints kept on file with the Department of Business Affairs and Consumer Protection and the Office of the City Clerk.

Said privilege shall be constructed in accordance with plans and specifications approved by the Zoning Department - Signs.

This grant of privilege in the public way shall be subject to the provisions of Section 10-28-015 and all other required provisions of the Municipal Code of Chicago.

The grantee shall pay to the City of Chicago as compensation for the privilege #1108330 herein granted the sum of one hundred (\$100.00) per annum in advance.

A 25% penalty will be added for payments received after due date.

The permit holder agrees to hold the City of Chicago harmless for any damage, relocation or replacement costs associated with damage, relocation or removal of private property caused by the City performing work in the public way.

Authority herein given and granted for a period of five (5) years from and after Date of Passage.

Alderman _____

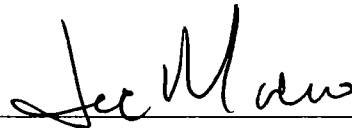

Proco Joe Moreno 1st Ward

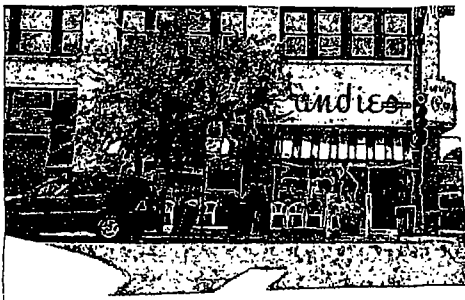

Canopy Drawings

Margies' Candies
1960 North Western
Chicago, Illinois 60647

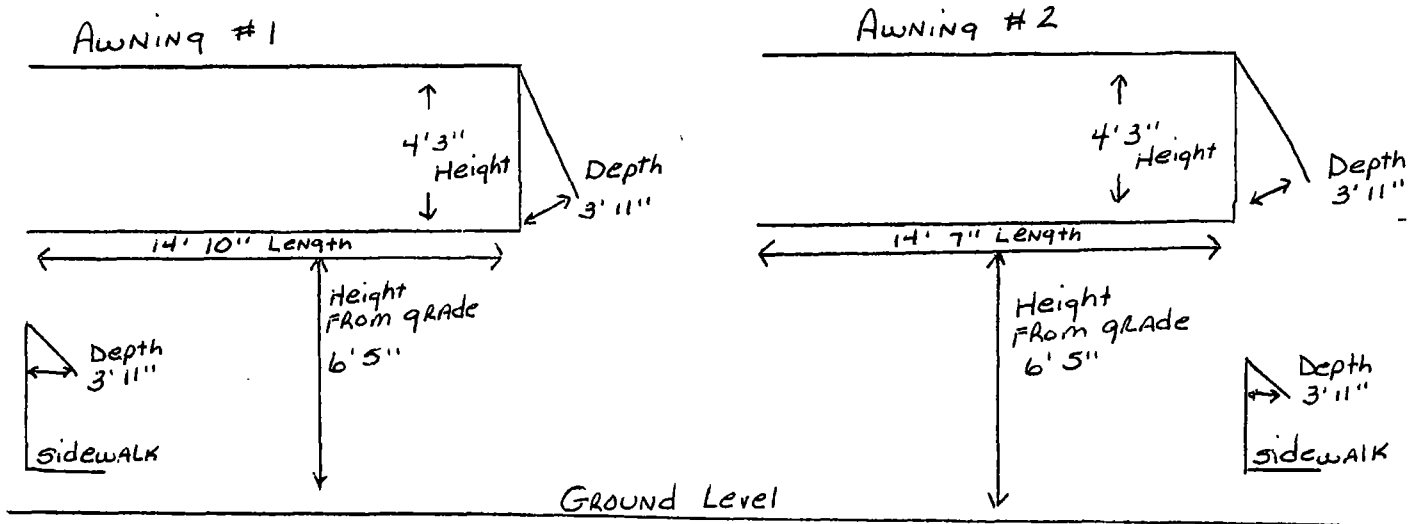

Western Avenue



05/28/2014

Alderman **Proco Joe Moreno**
Ward # **01**
City of Chicago
City Hall, Room **300**
121 North LaSalle Street
Chicago, Illinois 60602

Re: An ordinance to use and maintain a portion of the public right-of-way for **two (2) awning(s)** for **MARGIE'S CANDIES**, adjacent to the premises known as **1960 N. Western Ave.**

Dear Alderman **Proco Joe Moreno**:

The applicant referenced above has requested the use of the public right-of-way for a **awning(s)**. An ordinance has been prepared by the Department of Business Affairs and Consumer Protection – Small Business Center - Public Way Use Unit for presentation to the City Council. Because this request was made for properties located in your ward, as approved by you as per the attached, I respectfully request that you introduce the attached ordinance at the next City Council meeting.

If you have any questions regarding this ordinance, please contact Anthony Bertuca at (312) 744-5506.

Department of Business Affairs and Consumer Protection



City of Chicago

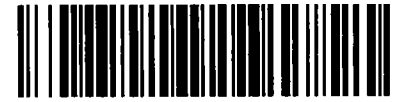

O2014-4311

Office of the City Clerk

Document Tracking Sheet

| | |
|---------------------------------|--|
| Meeting Date: | 5/28/2014 |
| Sponsor(s): | Moreno (1) |
| Type: | Ordinance |
| Title: | Awning(s) for Milk & Honey Cafe |
| Committee(s) Assignment: | Committee on Transportation and Public Way |

ORDINANCE
MILK & HONEY CAFE
Acct. No. 222564 - 1
Permit No. 1113108

Be It Ordained by the City Council of the City of Chicago:

SECTION 1. Permission and authority are hereby given and granted to MILK & HONEY CAFE, upon the terms and subject to the conditions of this ordinance to maintain and use, as now constructed, one (1) Awning(s) projecting over the public right-of-way adjacent to its premises known as 1920 W. Division St..

Said Awning(s) at W. Division Street measure(s):

One (1) at six (6) feet in length, and two point five (2.5) feet in width for a total of fifteen (15) square feet.

The location of said privilege shall be as shown on prints kept on file with the Department of Business Affairs and Consumer Protection and the Office of the City Clerk.

Said privilege shall be constructed in accordance with plans and specifications approved by the Zoning Department - Signs.

This grant of privilege in the public way shall be subject to the provisions of Section 10-28-015 and all other required provisions of the Municipal Code of Chicago.

The grantee shall pay to the City of Chicago as compensation for the privilege #1113108 herein granted the sum of fifty (\$50.00) per annum in advance.

A 25% penalty will be added for payments received after due date.

The permit holder agrees to hold the City of Chicago harmless for any damage, relocation or replacement costs associated with damage, relocation or removal of private property caused by the City performing work in the public way.

Authority herein given and granted for a period of five (5) years from and after .

Alderman _____



Proco Joe Moreno 1st Ward

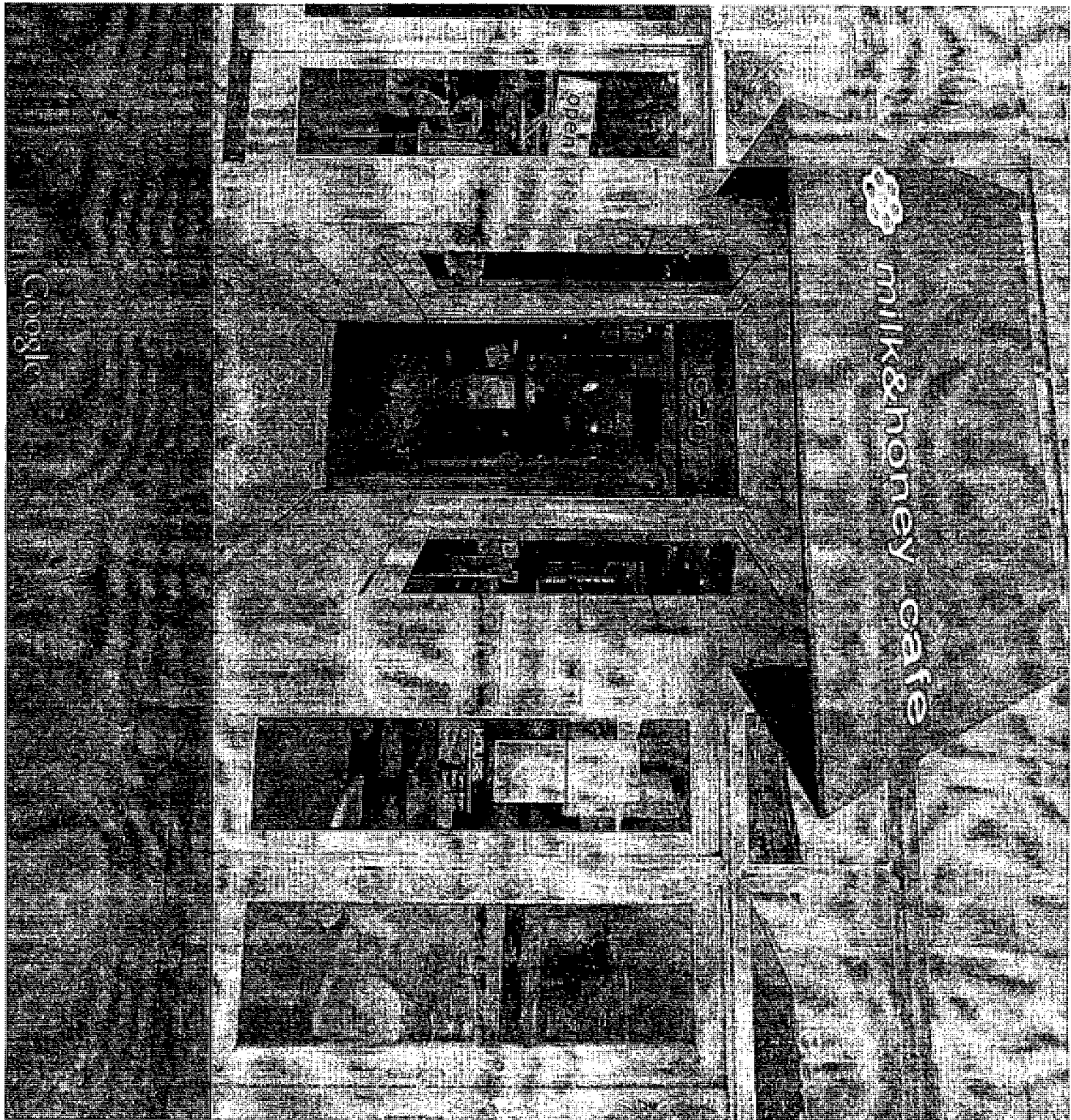



05/28/2014

Alderman **Proco Joe Moreno**
Ward # **01**
City of Chicago
City Hall, Room **300**
121 North LaSalle Street
Chicago, Illinois 60602

Re: An ordinance to use and maintain a portion of the public right-of-way for **one (1) awning(s)** for **MILK & HONEY CAFE**, adjacent to the premises known as **1920 W. Division St.**

Dear Alderman **Proco Joe Moreno**:

The applicant referenced above has requested the use of the public right-of-way for a **awning(s)**. An ordinance has been prepared by the Department of Business Affairs and Consumer Protection – Small Business Center - Public Way Use Unit for presentation to the City Council. Because this request was made for properties located in your ward, as approved by you as per the attached, I respectfully request that you introduce the attached ordinance at the next City Council meeting.

If you have any questions regarding this ordinance, please contact Anthony Bertuca at (312) 744-5506.

Department of Business Affairs and Consumer Protection



City of Chicago



O2014-4324

Office of the City Clerk Document Tracking Sheet

| | |
|---------------------------------|--|
| Meeting Date: | 5/28/2014 |
| Sponsor(s): | Moreno (1) |
| Type: | Ordinance |
| Title: | Awning(s) for Mirai Sushi |
| Committee(s) Assignment: | Committee on Transportation and Public Way |

ORDINANCE
MIRAI SUSHI
Acct. No. 23090 - 2
Permit No. 1113044

Be It Ordained by the City Council of the City of Chicago:

SECTION 1. Permission and authority are hereby given and granted to MIRAI SUSHI, upon the terms and subject to the conditions of this ordinance to maintain and use, as now constructed, one (1) Awning(s) projecting over the public right-of-way adjacent to its premises known as 2020 W. Division St..

Said Awning(s) at W. DIVISION measure(s):

One (1) at twelve (12) feet in length, and eleven (11) feet in width for a total of one hundred thirty-two (132) square feet.

The location of said privilege shall be as shown on prints kept on file with the Department of Business Affairs and Consumer Protection and the Office of the City Clerk.

Said privilege shall be constructed in accordance with plans and specifications approved by the Zoning Department - Signs.

This grant of privilege in the public way shall be subject to the provisions of Section 10-28-015 and all other required provisions of the Municipal Code of Chicago.

The grantee shall pay to the City of Chicago as compensation for the privilege #1113044 herein granted the sum of fifty (\$50.00) per annum in advance.

A 25% penalty will be added for payments received after due date.

The permit holder agrees to hold the City of Chicago harmless for any damage, relocation or replacement costs associated with damage, relocation or removal of private property caused by the City performing work in the public way.

Authority herein given and granted for a period of five (5) years from and after 05/13/2014.

Alderman _____

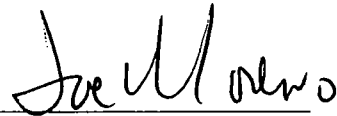

Proco Joe Moreno 1st Ward

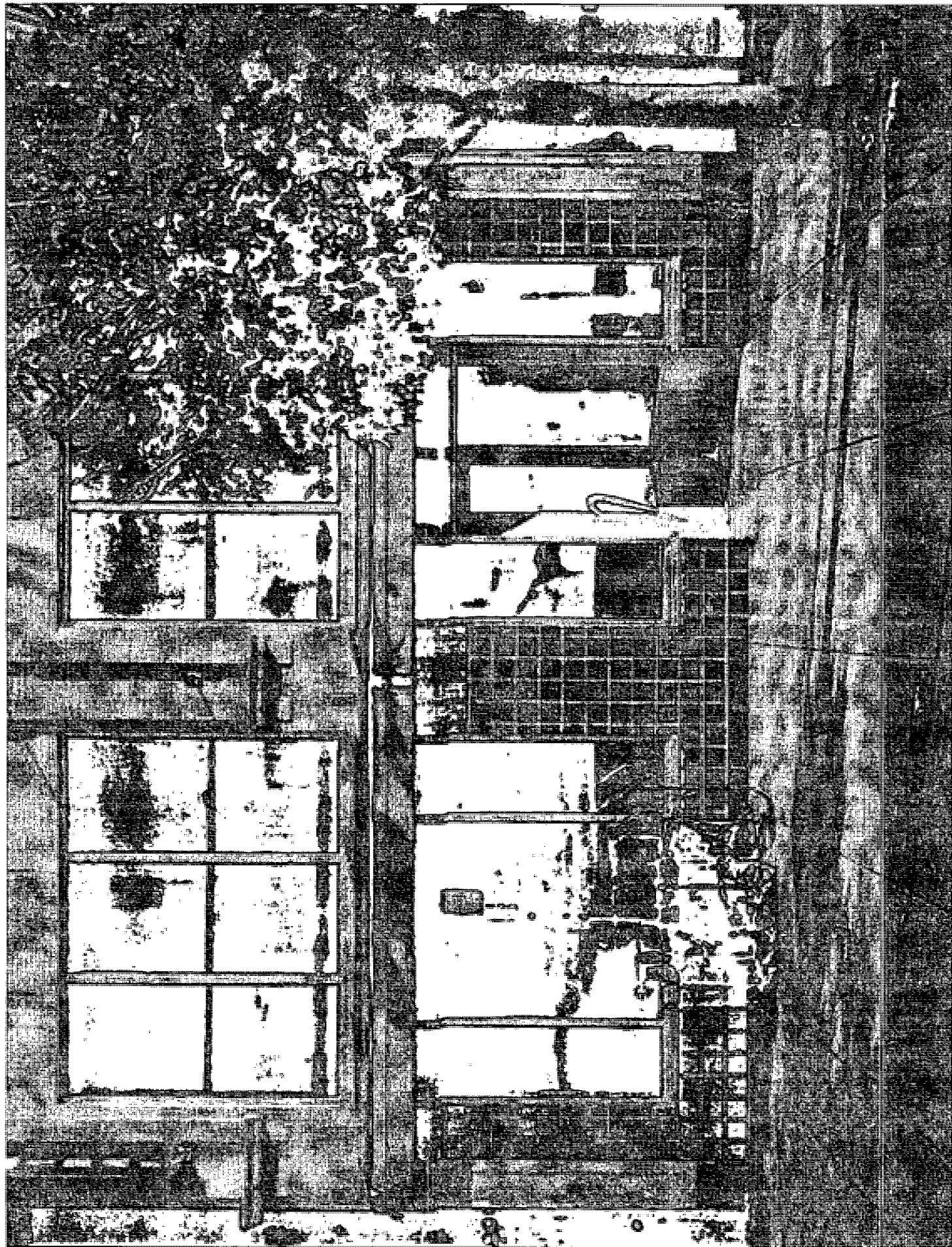



05/28/2014

Alderman **Proco Joe Moreno**
Ward # **01**
City of Chicago
City Hall, Room **300**
121 North LaSalle Street
Chicago, Illinois 60602

Re: An ordinance to use and maintain a portion of the public right-of-way for **one (1) awning(s)** for **MIRAI SUSHI**, adjacent to the premises known as **2020 W. Division St.**

Dear Alderman **Proco Joe Moreno**:

The applicant referenced above has requested the use of the public right-of-way for a **awning(s)**. An ordinance has been prepared by the Department of Business Affairs and Consumer Protection – Small Business Center - Public Way Use Unit for presentation to the City Council. Because this request was made for properties located in your ward, as approved by you as per the attached, I respectfully request that you introduce the attached ordinance at the next City Council meeting.

If you have any questions regarding this ordinance, please contact Anthony Bertuca at (312) 744-5506.

Department of Business Affairs and Consumer Protection



City of Chicago



O2014-4325

Office of the City Clerk

Document Tracking Sheet

| | |
|---------------------------------|--|
| Meeting Date: | 5/28/2014 |
| Sponsor(s): | Moreno (1) |
| Type: | Ordinance |
| Title: | Awning(s) for Runa Japanese |
| Committee(s) Assignment: | Committee on Transportation and Public Way |

ORDINANCE
Runa Japanese
Acct. No. 384063 - 1
Permit No. 1108262

Be It Ordained by the City Council of the City of Chicago:

SECTION 1. Permission and authority are hereby given and granted to Runa Japanese, upon the terms and subject to the conditions of this ordinance to construct, install, maintain and use one (1) Awning(s) projecting over the public right-of-way adjacent to its premises known as 2257 W. North Ave..

Said Awning(s) at North measure(s):

One (1) at twenty (20) feet in length, and four (4) feet in width for a total of eighty (80) square feet.

The location of said privilege shall be as shown on prints kept on file with the Department of Business Affairs and Consumer Protection and the Office of the City Clerk.

Said privilege shall be constructed in accordance with plans and specifications approved by the Zoning Department - Signs.

This grant of privilege in the public way shall be subject to the provisions of Section 10-28-015 and all other required provisions of the Municipal Code of Chicago.

The grantee shall pay to the City of Chicago as compensation for the privilege #1108262 herein granted the sum of fifty (\$50.00) per annum in advance.

A 25% penalty will be added for payments received after due date.

The permit holder agrees to hold the City of Chicago harmless for any damage, relocation or replacement costs associated with damage, relocation or removal of private property caused by the City performing work in the public way.

Authority herein given and granted for a period of five (5) years from and after Date of Passage.

Alderman _____ 

Proco Joe Moreno 1st Ward



Monsibic
 (Bridgeport)
 Chicago, IL
 3401 S. Halsted St.
 Chicago, IL 60608
 773-847-2828
 Fax 773-847-0088

SIGN ELEVATION EXHIBIT

Address: 2257 W North Ave
 City: Chicago
 State: IL
 Account Rep: _____
 Sales Rep: K. WONG

APPROVALS
 CLIENT _____
 DESIGN _____
 PROD _____
 Designer: K. WONG
 Design No _____
 DATE 08-01-13
 Rev Date _____

The purchaser agrees to hold the seller harmless against any claims for damages or expenses which may occur as a result of drilling for signs and foundations, including but not limited to areas containing any existing conduits, as well as the purchaser's existing marquee structure.

| SPECIFICATIONS | COLOR SCHEDULE | MOUNTING DETAIL |
|--|--|--|
| <ol style="list-style-type: none"> Awning Fabric Material 1"X 1" SQUARE TUBE FRAME 3/16" GALVANIZED STEEL Z-CLIP ATTACHMENT APPROPRIATE NON-CORROSIVE WALL FASTENER SEE MOUNTING OPTION DETAILS #12 TEK SCREW | <p>White</p> <p>Red</p> <p>R-176 Red</p> | <p>Thru-Bolt Mounting</p> <p>Hanger Bolts</p> <p>Reverse Toggle Bolt Mounting</p> <p>Masonry Lag Bolt Mounting</p> |

THIS DESIGN AND ENGINEERING IS SUBMITTED AS OUR PROPOSAL, AND THE RIGHT TO USE OR EXHIBIT IN ANY FORM, IS NOT AUTHORIZED WITHOUT WRITTEN PERMISSION BY MONSIBIC, INC



Department of Business Affairs and Consumer Protection
Small Business Center - Public Way Use Unit
City Hall - 121 N. LaSalle Street, Room 800 • Chicago, IL 60602
(312)-74-GOBIZ (312-744-6249) • (312) 744-1944 (TTY)
<http://www.cityofchicago.org/bacp>

05/28/2014

Alderman **Proco Joe Moreno**
Ward # **01**
City of Chicago
City Hall, Room **300**
121 North LaSalle Street
Chicago, Illinois 60602

Re: An ordinance to use and maintain a portion of the public right-of-way for **one (1) awning(s)** for **Runa Japanese**, adjacent to the premises known as **2257 W. North Ave.**.

Dear Alderman **Proco Joe Moreno**:

The applicant referenced above has requested the use of the public right-of-way for a **awning(s)**. An ordinance has been prepared by the Department of Business Affairs and Consumer Protection – Small Business Center - Public Way Use Unit for presentation to the City Council. Because this request was made for properties located in your ward, as approved by you as per the attached, I respectfully request that you introduce the attached ordinance at the next City Council meeting.

If you have any questions regarding this ordinance, please contact Anthony Bertuca at (312) 744-5506.

Department of Business Affairs and Consumer Protection



City of Chicago



O2014-4329

Office of the City Clerk

Document Tracking Sheet

| | |
|---------------------------------|--|
| Meeting Date: | 5/28/2014 |
| Sponsor(s): | Fioretti (2) |
| Type: | Ordinance |
| Title: | Awning(s) for Lou Malnati's Pizzeria |
| Committee(s) Assignment: | Committee on Transportation and Public Way |

ORDINANCE
LOU MALNATI'S PIZZERIA
Acct. No. 50161 - 5
Permit No. 1112936

Be It Ordained by the City Council of the City of Chicago:

SECTION 1. Permission and authority are hereby given and granted to LOU MALNATI'S PIZZERIA, upon the terms and subject to the conditions of this ordinance to maintain and use, as now constructed, two (2) Awning(s) projecting over the public right-of-way adjacent to its premises known as 805 S. State St..

Said Awning(s) at S STATE ST measure(s):

Two (2) at ten point six seven (10.67) feet in length, and four (4) feet in width for a total of eighty-five point three six (85.36) square feet.

The location of said privilege shall be as shown on prints kept on file with the Department of Business Affairs and Consumer Protection and the Office of the City Clerk.

Said privilege shall be constructed in accordance with plans and specifications approved by the Zoning Department - Signs.

This grant of privilege in the public way shall be subject to the provisions of Section 10-28-015 and all other required provisions of the Municipal Code of Chicago.

The grantee shall pay to the City of Chicago as compensation for the privilege #1112936 herein granted the sum of one hundred (\$100.00) per annum in advance.

A 25% penalty will be added for payments received after due date.

The permit holder agrees to hold the City of Chicago harmless for any damage, relocation or replacement costs associated with damage, relocation or removal of private property caused by the City performing work in the public way.

Authority herein given and granted for a period of five (5) years from and after 05/13/2014.

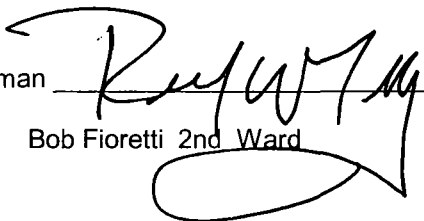
Alderman 
Bob Fioretti 2nd Ward

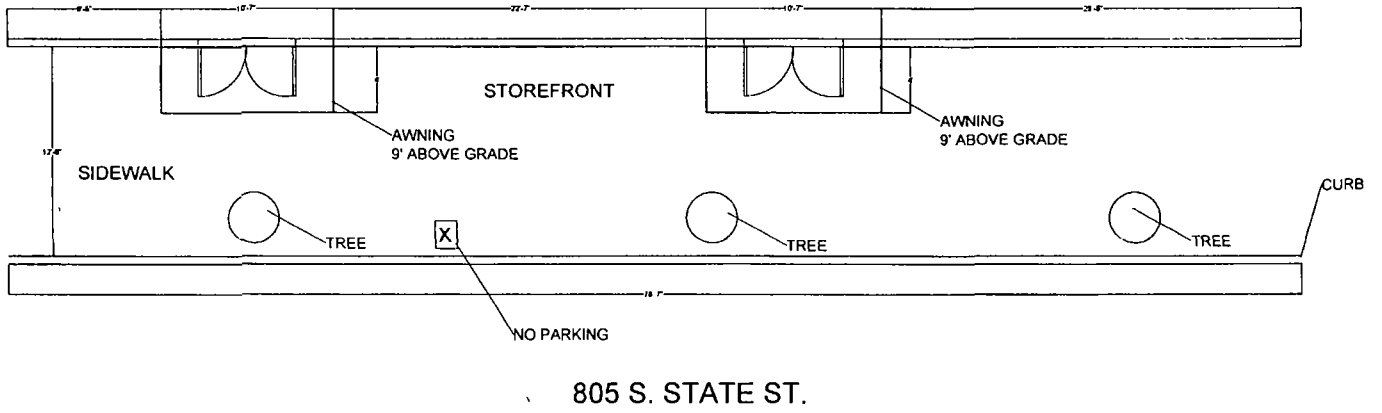

LOU MALNATI'S SOUTH LOOP EXTERIOR
STREET PLAN
SCALE: $\frac{3}{16}$ " = 1'-0"



05/28/2014

Alderman **Bob Fioretti**
Ward # **02**
City of Chicago
City Hall, Room **300**
121 North LaSalle Street
Chicago, Illinois 60602

Re: An ordinance to use and maintain a portion of the public right-of-way for **two (2) awning(s)** for **LOU MALNATT'S PIZZERIA**, adjacent to the premises known as **805 S. State St.**

Dear Alderman **Bob Fioretti**:

The applicant referenced above has requested the use of the public right-of-way for a **awning(s)**. An ordinance has been prepared by the Department of Business Affairs and Consumer Protection – Small Business Center - Public Way Use Unit for presentation to the City Council. Because this request was made for properties located in your ward, as approved by you as per the attached, I respectfully request that you introduce the attached ordinance at the next City Council meeting.

If you have any questions regarding this ordinance, please contact Anthony Bertuca at (312) 744-5506.

Department of Business Affairs and Consumer Protection



City of Chicago



O2014-4334

Office of the City Clerk

Document Tracking Sheet

| | |
|---------------------------------|--|
| Meeting Date: | 5/28/2014 |
| Sponsor(s): | Fioretti (2) |
| Type: | Ordinance |
| Title: | Awning(s) for Standing Room Only Chicago |
| Committee(s) Assignment: | Committee on Transportation and Public Way |

ORDINANCE
STANDING ROOM ONLY CHICAGO
Acct. No. 14194 - 1
Permit No. 1112715

Be It Ordained by the City Council of the City of Chicago:

SECTION 1. Permission and authority are hereby given and granted to STANDING ROOM ONLY CHICAGO, upon the terms and subject to the conditions of this ordinance to maintain and use, as now constructed, one (1) Awning(s) projecting over the public right-of-way adjacent to its premises known as 610 S. Dearborn St..

Said Awning(s) at S. DEARBORN ST. measure(s):

One (1) at ten point three (10.3) feet in length, and two point six (2.6) feet in width for a total of twenty-six point seven eight (26.78) square feet.

The location of said privilege shall be as shown on prints kept on file with the Department of Business Affairs and Consumer Protection and the Office of the City Clerk.

Said privilege shall be constructed in accordance with plans and specifications approved by the Zoning Department - Signs.

This grant of privilege in the public way shall be subject to the provisions of Section 10-28-015 and all other required provisions of the Municipal Code of Chicago.

The grantee shall pay to the City of Chicago as compensation for the privilege #1112715 herein granted the sum of fifty (\$50.00) per annum in advance.

A 25% penalty will be added for payments received after due date.

The permit holder agrees to hold the City of Chicago harmless for any damage, relocation or replacement costs associated with damage, relocation or removal of private property caused by the City performing work in the public way.

Authority herein given and granted for a period of five (5) years from and after 04/26/2014.

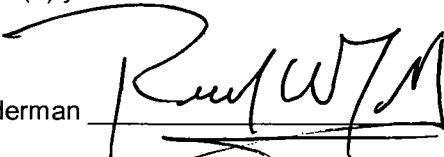
Alderman 
Bob Fieretti 2nd Ward

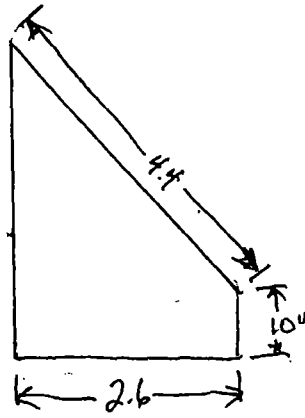
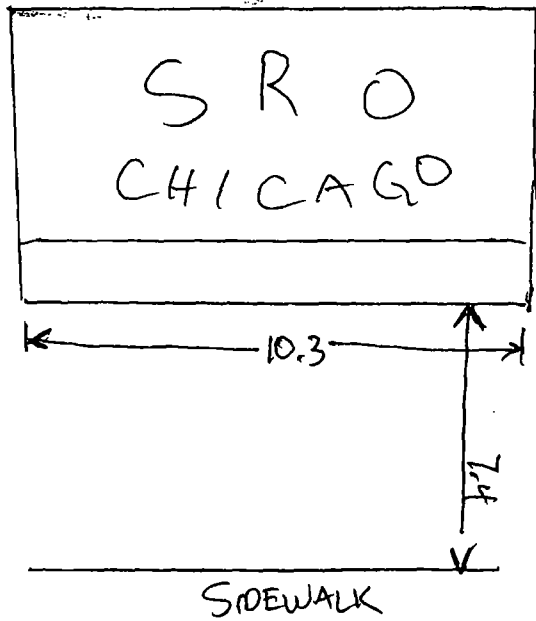



05/28/2014

Alderman **Bob Fioretti**
Ward # **02**
City of Chicago
City Hall, Room **300**
121 North LaSalle Street
Chicago, Illinois 60602

Re: An ordinance to use and maintain a portion of the public right-of-way for **one (1) awning(s)** for
STANDING ROOM ONLY CHICAGO, adjacent to the premises known as **610 S. Dearborn St.**

Dear Alderman **Bob Fioretti**:

The applicant referenced above has requested the use of the public right-of-way for a **awning(s)**. An ordinance has been prepared by the Department of Business Affairs and Consumer Protection – Small Business Center - Public Way Use Unit for presentation to the City Council. Because this request was made for properties located in your ward, as approved by you as per the attached, I respectfully request that you introduce the attached ordinance at the next City Council meeting.

If you have any questions regarding this ordinance, please contact Anthony Bertuca at (312) 744-5506.

Department of Business Affairs and Consumer Protection



City of Chicago



O2014-4337

Office of the City Clerk

Document Tracking Sheet

| | |
|---------------------------------|--|
| Meeting Date: | 5/28/2014 |
| Sponsor(s): | Fioretti (2) |
| Type: | Ordinance |
| Title: | Awning(s) for 7-Eleven |
| Committee(s) Assignment: | Committee on Transportation and Public Way |

ORDINANCE
7-ELEVEN
Acct. No. 65465 - 102
Permit No. 1112979

Be It Ordained by the City Council of the City of Chicago:

SECTION 1. Permission and authority are hereby given and granted to 7-ELEVEN, upon the terms and subject to the conditions of this ordinance to maintain and use, as now constructed, two (2) Awning(s) projecting over the public right-of-way adjacent to its premises known as 833 W. Van Buren St..

Said Awning(s) at W. Van Buren Street measure(s):

One (1) at nineteen (19) feet in length, and three (3) feet in width for a total of fifty-seven (57) square feet.

Said Awning(s) at S. Green Steet measure(s):

One (1) at nineteen (19) feet in length, and three (3) feet in width for a total of fifty-seven (57) square feet.

The location of said privilege shall be as shown on prints kept on file with the Department of Business Affairs and Consumer Protection and the Office of the City Clerk.

Said privilege shall be constructed in accordance with plans and specifications approved by the Zoning Department - Signs.

This grant of privilege in the public way shall be subject to the provisions of Section 10-28-015 and all other required provisions of the Municipal Code of Chicago.

The grantee shall pay to the City of Chicago as compensation for the privilege #1112979 herein granted the sum of one hundred (\$100.00) per annum in advance.

A 25% penalty will be added for payments received after due date.

The permit holder agrees to hold the City of Chicago harmless for any damage, relocation or replacement costs associated with damage, relocation or removal of private property caused by the City performing work in the public way.

Authority herein given and granted for a period of five (5) years from and after 04/22/2014.

Alderman

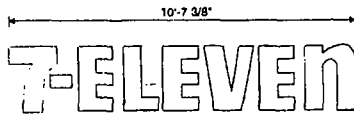

Bob Fioretti 2nd Ward



2 REQUIRED
3/8" = 1'

- (2) NEON INT. ILLUMINATED LETTER SET
- 7-ELEVEN LETTER SET
- WHITE PLEX FACES
- TRIM CAP TO MATCH GREEN W/RETURNS TO MATCH
- DK. BRONZE

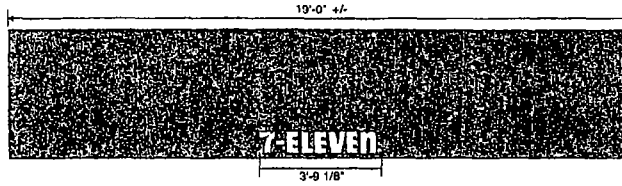
ILLUMINATED W/WHITE NEON
RCWY. MOUNTED. RCWY TO BE PAINTED TO MATCH BUILDING FACE.



COVER (2) EXISTING AWNINGS
COVER WITH SUNBRELLA FIRE-SIST. FOREST GREEN FABRIC
WITH FIRST SURFACE APPLIED GRAPHICS ON VALANCE
TO MATCH OPAQUE WHITE.
FRAME TO BE PAINTED BLACK WITH M.A.P. ACRYLIC
POLYURETHANE (2 COATS)

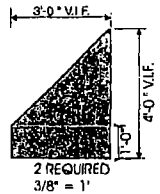

2 REQUIRED
3/8" = 1'

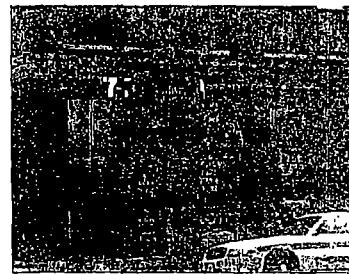
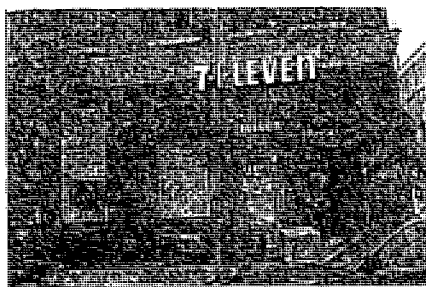

DOYLE
GENERAL SIGN CONTRACTORS
233 INDEPENDENCE RD. P.O. BOX 1088 800-843-8180
ADDISON, TX 75110 FAX 972-543-8518

| DATE | REVISION |
|----------|---------------|
| 01-04-07 | PER NOTATIONS |
| | |
| | |
| | |

CUSTOMER APPROVAL _____ DATE _____

The design is the original and unpublished work of DOYLE SIGNS, INC. and may not be reproduced, copied or exhibited in any fashion without the expressed written consent from an authorized officer of The Company. The rights to this design may be purchased.

CLIENT 7-ELEVEN #9013/33901

ADDRESS 833 VAN BUREN STATE IL DESIGNER JR SALESPERSON TO

CITY CHICAGO

DRWG. NO. 8930 SCALE: NOTED DATE: 12-22-06 SHEET NO. 1 OF 1



05/28/2014

Alderman **Bob Fioretti**
Ward # **02**
City of Chicago
City Hall, Room **300**
121 North LaSalle Street
Chicago, Illinois 60602

Re: An ordinance to use and maintain a portion of the public right-of-way for **two (2) awning(s)** for **7-ELEVEN**, adjacent to the premises known as **833 W. Van Buren St.**

Dear Alderman **Bob Fioretti**:

The applicant referenced above has requested the use of the public right-of-way for a **awning(s)**. An ordinance has been prepared by the Department of Business Affairs and Consumer Protection – Small Business Center - Public Way Use Unit for presentation to the City Council. Because this request was made for properties located in your ward, as approved by you as per the attached, I respectfully request that you introduce the attached ordinance at the next City Council meeting.

If you have any questions regarding this ordinance, please contact Anthony Bertuca at (312) 744-5506.

Department of Business Affairs and Consumer Protection



City of Chicago

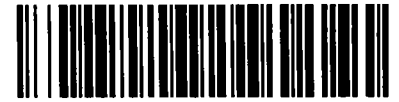

O2014-4342

Office of the City Clerk

Document Tracking Sheet

| | |
|---------------------------------|--|
| Meeting Date: | 5/28/2014 |
| Sponsor(s): | Hairston (5) |
| Type: | Ordinance |
| Title: | Awning(s) for Quick Snacks, Inc. |
| Committee(s) Assignment: | Committee on Transportation and Public Way |

ORDINANCE
QUICK SNACKS, INC.
Acct. No. 248373 - 1
Permit No. 1112999

Be It Ordained by the City Council of the City of Chicago:

SECTION 1. Permission and authority are hereby given and granted to QUICK SNACKS, INC., upon the terms and subject to the conditions of this ordinance to maintain and use, as now constructed, one (1) Awning(s) projecting over the public right-of-way adjacent to its premises known as 1658 E. 55th St..

Said Awning(s) at E. 55th Street measure(s):

One (1) at eighteen (18) feet in length, and two point one seven (2.17) feet in width for a total of thirty-nine point zero six (39.06) square feet.

The location of said privilege shall be as shown on prints kept on file with the Department of Business Affairs and Consumer Protection and the Office of the City Clerk.

Said privilege shall be constructed in accordance with plans and specifications approved by the Zoning Department - Signs.

This grant of privilege in the public way shall be subject to the provisions of Section 10-28-015 and all other required provisions of the Municipal Code of Chicago.

The grantee shall pay to the City of Chicago as compensation for the privilege #1112999 herein granted the sum of fifty (\$50.00) per annum in advance.

A 25% penalty will be added for payments received after due date.

The permit holder agrees to hold the City of Chicago harmless for any damage, relocation or replacement costs associated with damage, relocation or removal of private property caused by the City performing work in the public way.

Authority herein given and granted for a period of five (5) years from and after 09/10/2013.

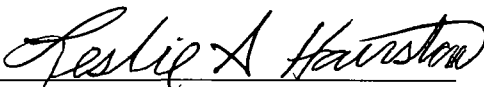
Alderman 

Leslie Hairston 5th Ward

EXAMPLE OF CANOPY DIMENSIONS.

QUICK SNACKS
1658 EAST 55th ST.

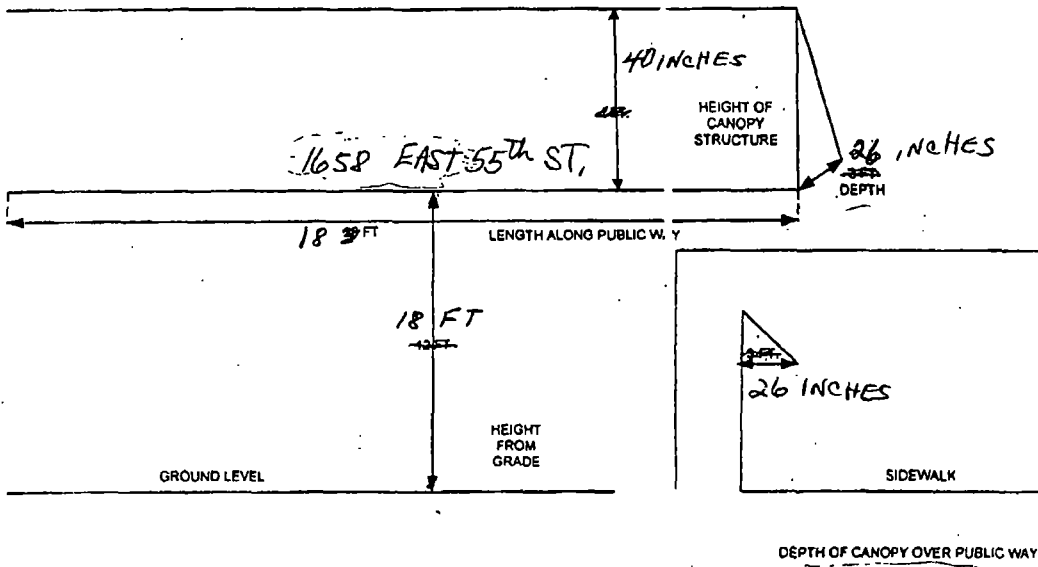



City of Chicago



O2014-4343

Office of the City Clerk

Document Tracking Sheet

| | |
|---------------------------------|--|
| Meeting Date: | 5/28/2014 |
| Sponsor(s): | Hairston (5) |
| Type: | Ordinance |
| Title: | Awning(s) for Subway |
| Committee(s) Assignment: | Committee on Transportation and Public Way |

ORDINANCE
SUBWAY
Acct. No. 271026 - 1
Permit No. 1112868

Be It Ordained by the City Council of the City of Chicago:

SECTION 1. Permission and authority are hereby given and granted to SUBWAY, upon the terms and subject to the conditions of this ordinance to maintain and use, as now constructed, one (1) Awning(s) projecting over the public right-of-way adjacent to its premises known as 1449 E. 57th St..

Said Awning(s) at E. 57th Street measure(s):

One (1) at seventeen (17) feet in length, and two point five (2.5) feet in width for a total of forty-two point five (42.5) square feet.

The location of said privilege shall be as shown on prints kept on file with the Department of Business Affairs and Consumer Protection and the Office of the City Clerk.

Said privilege shall be constructed in accordance with plans and specifications approved by the Zoning Department - Signs.

This grant of privilege in the public way shall be subject to the provisions of Section 10-28-015 and all other required provisions of the Municipal Code of Chicago.

The grantee shall pay to the City of Chicago as compensation for the privilege #1112868 herein granted the sum of fifty (\$50.00) per annum in advance.

A 25% penalty will be added for payments received after due date.

The permit holder agrees to hold the City of Chicago harmless for any damage, relocation or replacement costs associated with damage, relocation or removal of private property caused by the City performing work in the public way.

Authority herein given and granted for a period of five (5) years from and after 01/13/2014.

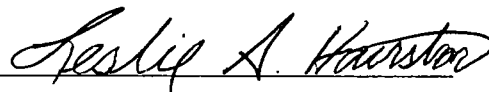
Alderman 

Leslie Hairston 5th Ward

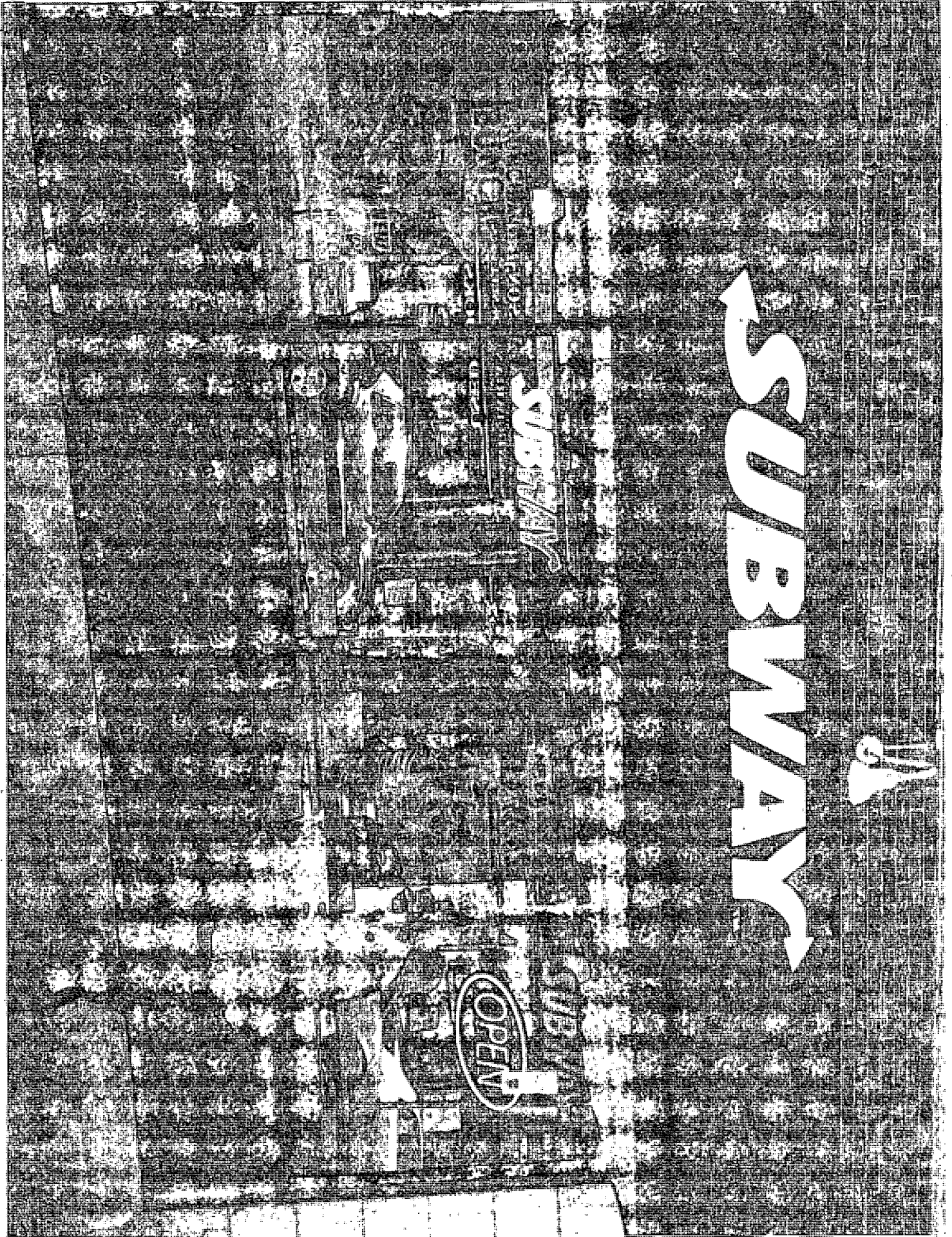



City of Chicago



O2014-4346

Office of the City Clerk

Document Tracking Sheet

| | |
|---------------------------------|--|
| Meeting Date: | 5/28/2014 |
| Sponsor(s): | Hairston (5) |
| Type: | Ordinance |
| Title: | Awning(s) for Vogue Cleaners |
| Committee(s) Assignment: | Committee on Transportation and Public Way |

ORDINANCE
VOGUE CLEANERS
Acct. No. 55349 - 1
Permit No. 1112966

Be It Ordained by the City Council of the City of Chicago:

SECTION 1. Permission and authority are hereby given and granted to VOGUE CLEANERS, upon the terms and subject to the conditions of this ordinance to maintain and use, as now constructed, one (1) Awning(s) projecting over the public right-of-way adjacent to its premises known as 1442 E. 57th St..

Said Awning(s) at E. 57th Street measure(s):

One (1) at nineteen (19) feet in length, and two (2) feet in width for a total of thirty-eight (38) square feet.

The location of said privilege shall be as shown on prints kept on file with the Department of Business Affairs and Consumer Protection and the Office of the City Clerk.

Said privilege shall be constructed in accordance with plans and specifications approved by the Zoning Department - Signs.

This grant of privilege in the public way shall be subject to the provisions of Section 10-28-015 and all other required provisions of the Municipal Code of Chicago.

The grantee shall pay to the City of Chicago as compensation for the privilege #1112966 herein granted the sum of fifty (\$50.00) per annum in advance.

A 25% penalty will be added for payments received after due date.

The permit holder agrees to hold the City of Chicago harmless for any damage, relocation or replacement costs associated with damage, relocation or removal of private property caused by the City performing work in the public way.

Authority herein given and granted for a period of five (5) years from and after 03/18/2014.

Alderman 

Leslie Hairston 5th Ward

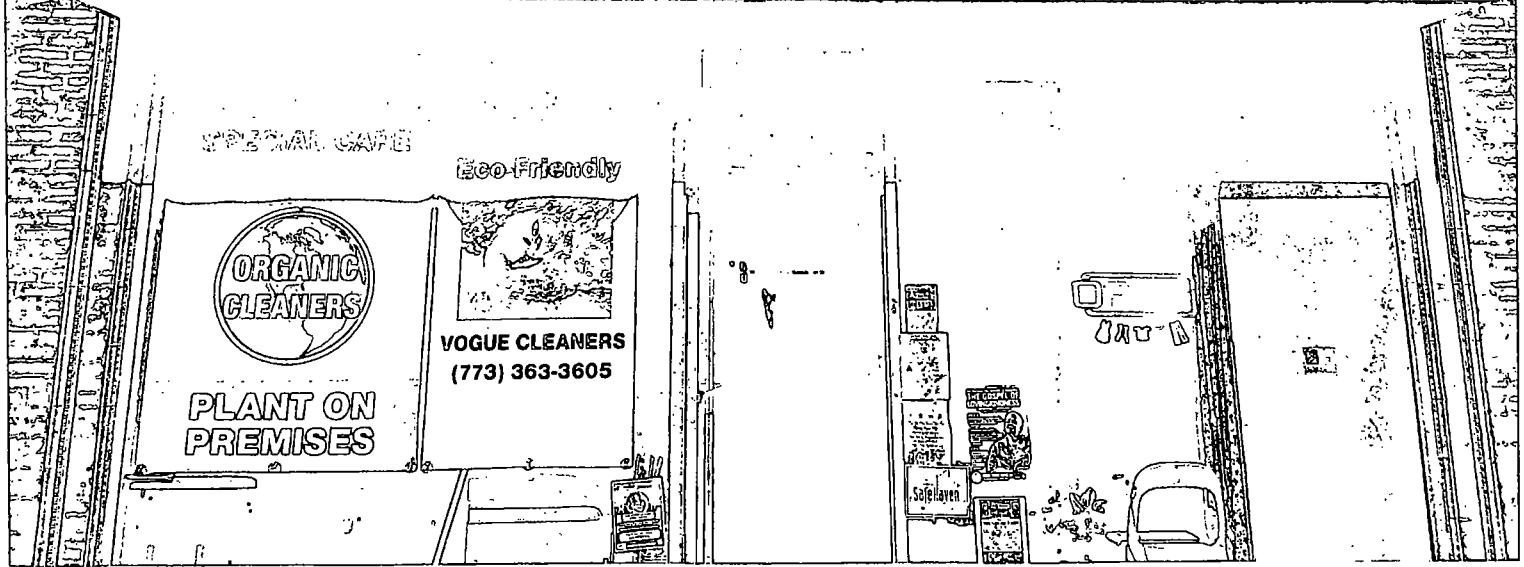
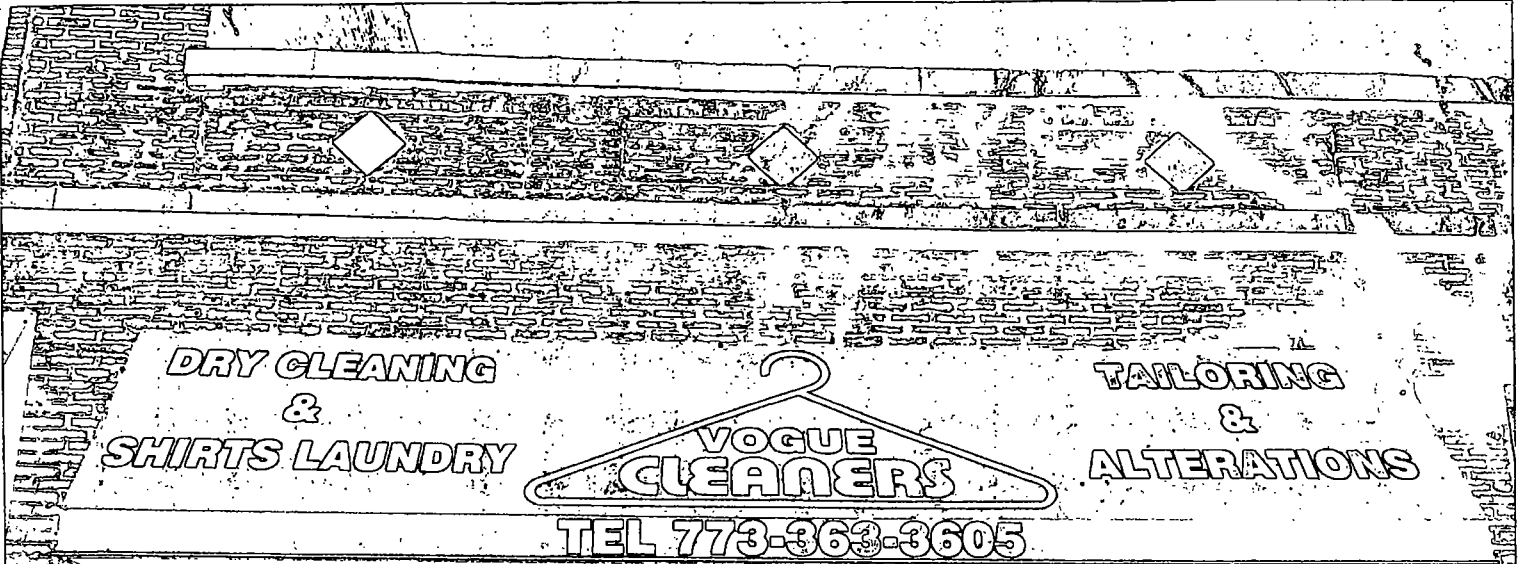



City of Chicago



O2014-4350

Office of the City Clerk

Document Tracking Sheet

| | |
|---------------------------------|--|
| Meeting Date: | 5/28/2014 |
| Sponsor(s): | Sawyer (6) |
| Type: | Ordinance |
| Title: | Awning(s) for Chatham Jewelry & Loan, Inc. |
| Committee(s) Assignment: | Committee on Transportation and Public Way |

ORDINANCE
CHATHAM JEWELRY & LOAN, INC.
Acct. No. 314201 - 1
Permit No. 1113002

Be It Ordained by the City Council of the City of Chicago:

SECTION 1. Permission and authority are hereby given and granted to CHATHAM JEWELRY & LOAN, INC., upon the terms and subject to the conditions of this ordinance to maintain and use, as now constructed, one (1) Awning(s) projecting over the public right-of-way adjacent to its premises known as 645-47 E. 79th St..

Said Awning(s) at E. 79th St measure(s):

One (1) at forty-seven point five (47.5) feet in length, and two point five (2.5) feet in width for a total of one hundred eighteen point seven five (118.75) square feet.

The location of said privilege shall be as shown on prints kept on file with the Department of Business Affairs and Consumer Protection and the Office of the City Clerk.

Said privilege shall be constructed in accordance with plans and specifications approved by the Zoning Department - Signs.

This grant of privilege in the public way shall be subject to the provisions of Section 10-28-015 and all other required provisions of the Municipal Code of Chicago.

The grantee shall pay to the City of Chicago as compensation for the privilege #1113002 herein granted the sum of seventy-two dollars and fifty cents (\$72.50) per annum in advance.

A 25% penalty will be added for payments received after due date.

The permit holder agrees to hold the City of Chicago harmless for any damage, relocation or replacement costs associated with damage, relocation or removal of private property caused by the City performing work in the public way.

Authority herein given and granted for a period of five (5) years from and after 04/22/2014.

Alderman 

Roderick T. Sawyer 6th Ward



| <u>Exact Street</u> | <u>Qty</u> | <u>Length</u> | <u>Width</u> | <u>Depth</u> | <u>Height / Height Above Grade</u> |
|---------------------|------------|---------------|--------------|--------------|------------------------------------|
| E. 79th St | | 47.5 | 2.5 | 2.5 | 8.66 |

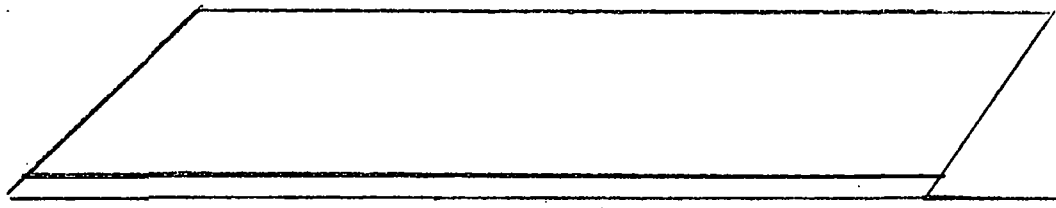

WEST ← → EAST
Sign is in the middle of the block in between Langley and Champlain - approx.
60 feet to each intersection.

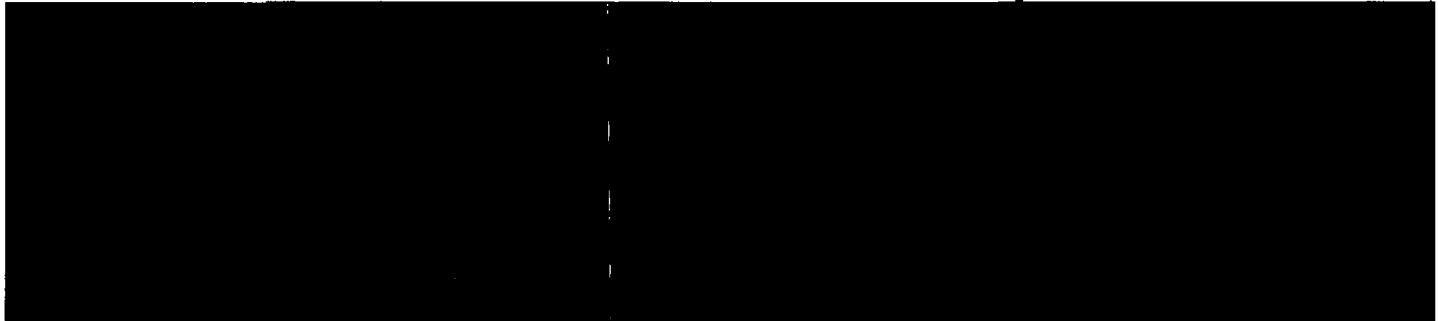



05/28/2014

Alderman **Roderick T. Sawyer**
Ward # **06**
City of Chicago
City Hall, Room **300**
121 North LaSalle Street
Chicago, Illinois 60602

Re: An ordinance to use and maintain a portion of the public right-of-way for **one (1) awning(s)** for
CHATHAM JEWELRY & LOAN, INC., adjacent to the premises known as **645-47 E. 79th St.**.

Dear Alderman **Roderick T. Sawyer**:

The applicant referenced above has requested the use of the public right-of-way for a **awning(s)**. An ordinance has been prepared by the Department of Business Affairs and Consumer Protection – Small Business Center - Public Way Use Unit for presentation to the City Council. Because this request was made for properties located in your ward, as approved by you as per the attached, I respectfully request that you introduce the attached ordinance at the next City Council meeting.

If you have any questions regarding this ordinance, please contact Anthony Bertuca at (312) 744-5506.

Department of Business Affairs and Consumer Protection



City of Chicago



O2014-4353

Office of the City Clerk Document Tracking Sheet

| | |
|---------------------------------|--|
| Meeting Date: | 5/28/2014 |
| Sponsor(s): | Sawyer (6) |
| Type: | Ordinance |
| Title: | Awning(s) for Sapstein Drugs |
| Committee(s) Assignment: | Committee on Transportation and Public Way |

ORDINANCE
SAPSTEIN DRUGS
Acct. No. 23285 - 2
Permit No. 1113032

Be It Ordained by the City Council of the City of Chicago:

SECTION 1. Permission and authority are hereby given and granted to SAPSTEIN DRUGS, upon the terms and subject to the conditions of this ordinance to maintain and use, as now constructed, one (1) Awning(s) projecting over the public right-of-way adjacent to its premises known as 752 E. 83rd St..

Said Awning(s) at E. 83RD ST. measure(s):

One (1) at twenty-two (22) feet in length, and four (4) feet in width for a total of eighty-eight (88) square feet.

The location of said privilege shall be as shown on prints kept on file with the Department of Business Affairs and Consumer Protection and the Office of the City Clerk.

Said privilege shall be constructed in accordance with plans and specifications approved by the Zoning Department - Signs.

This grant of privilege in the public way shall be subject to the provisions of Section 10-28-015 and all other required provisions of the Municipal Code of Chicago.

The grantee shall pay to the City of Chicago as compensation for the privilege #1113032 herein granted the sum of fifty (\$50.00) per annum in advance.

A 25% penalty will be added for payments received after due date.

The permit holder agrees to hold the City of Chicago harmless for any damage, relocation or replacement costs associated with damage, relocation or removal of private property caused by the City performing work in the public way.

Authority herein given and granted for a period of five (5) years from and after 04/22/2014.

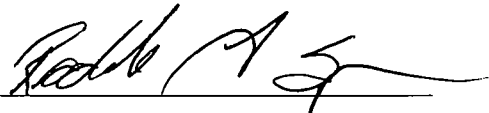
Alderman 
Roderick T. Sawyer 6th Ward

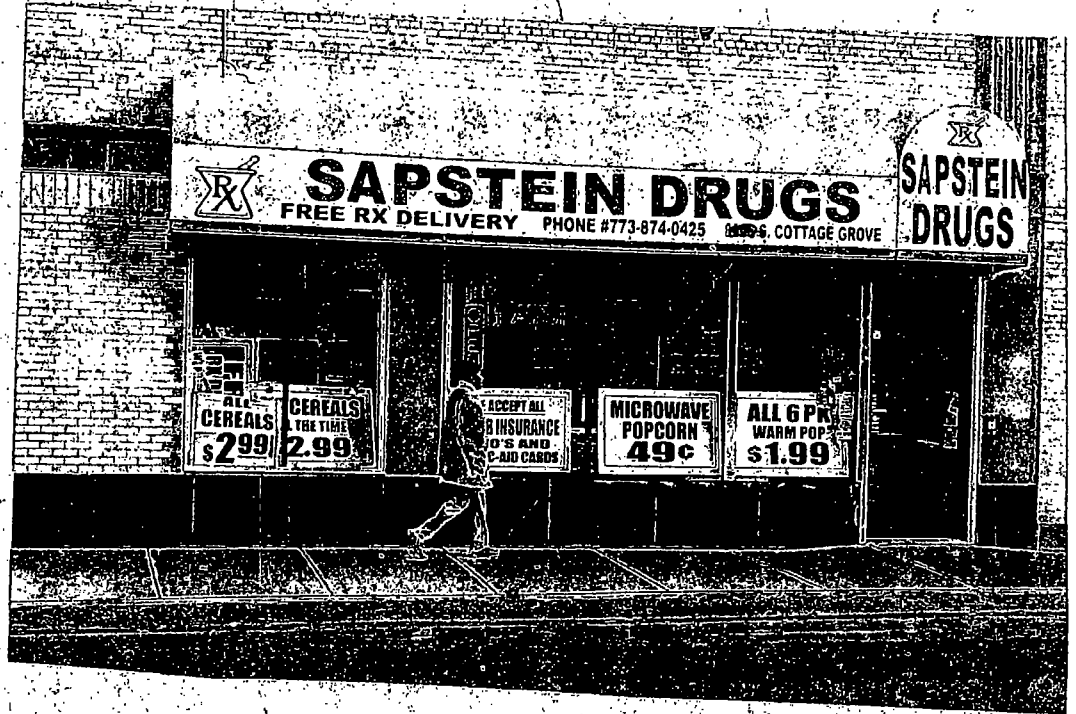



05/28/2014

Alderman **Roderick T. Sawyer**
Ward # **06**
City of Chicago
City Hall, Room **300**
121 North LaSalle Street
Chicago, Illinois 60602

Re: An ordinance to use and maintain a portion of the public right-of-way for **one (1) awning(s)** for **SAPSTEIN DRUGS**, adjacent to the premises known as **752 E. 83rd St.**

Dear Alderman **Roderick T. Sawyer**:

The applicant referenced above has requested the use of the public right-of-way for a **awning(s)**. An ordinance has been prepared by the Department of Business Affairs and Consumer Protection – Small Business Center - Public Way Use Unit for presentation to the City Council. Because this request was made for properties located in your ward, as approved by you as per the attached, I respectfully request that you introduce the attached ordinance at the next City Council meeting.

If you have any questions regarding this ordinance, please contact Anthony Bertuca at (312) 744-5506.

Department of Business Affairs and Consumer Protection



City of Chicago



O2014-4360

Office of the City Clerk

Document Tracking Sheet

| | |
|---------------------------------|--|
| Meeting Date: | 5/28/2014 |
| Sponsor(s): | Harris (8) |
| Type: | Ordinance |
| Title: | Awning(s) for Links to Learning Child Care |
| Committee(s) Assignment: | Committee on Transportation and Public Way |

ORDINANCE
LINKS TO LEARNING CHILD CARE
Acct. No. 337635 - 1
Permit No. 1112716

Be It Ordained by the City Council of the City of Chicago:

SECTION 1. Permission and authority are hereby given and granted to LINKS TO LEARNING CHILD CARE, upon the terms and subject to the conditions of this ordinance to maintain and use, as now constructed, one (1) Awning(s) projecting over the public right-of-way adjacent to its premises known as 8515 S. Stony Island Ave..

Said Awning(s) at S STONY ISLAND AVE measure(s):
One (1) at fifty (50) feet in length, and four (4) feet in width for a total of two hundred (200) square feet.

The location of said privilege shall be as shown on prints kept on file with the Department of Business Affairs and Consumer Protection and the Office of the City Clerk.

Said privilege shall be constructed in accordance with plans and specifications approved by the Zoning Department - Signs.

This grant of privilege in the public way shall be subject to the provisions of Section 10-28-015 and all other required provisions of the Municipal Code of Chicago.

The grantee shall pay to the City of Chicago as compensation for the privilege #1112716 herein granted the sum of seventy-five (\$75.00) per annum in advance.

A 25% penalty will be added for payments received after due date.

The permit holder agrees to hold the City of Chicago harmless for any damage, relocation or replacement costs associated with damage, relocation or removal of private property caused by the City performing work in the public way.

Authority herein given and granted for a period of five (5) years from and after 04/22/2014.

Alderman 

Michelle A. Harris 8th Ward

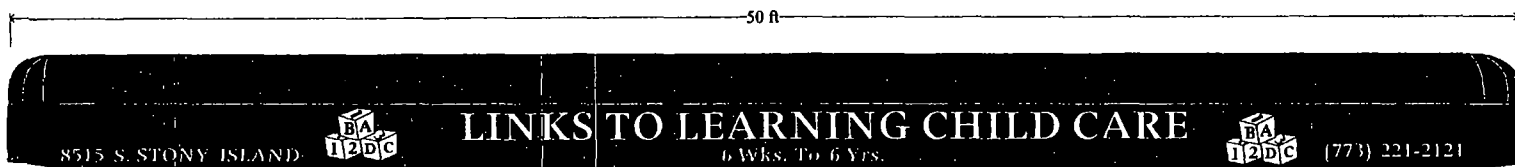



05/28/2014

Alderman **Michelle A. Harris**
Ward # **08**
City of Chicago
City Hall, Room **300**
121 North LaSalle Street
Chicago, Illinois 60602

Re: An ordinance to use and maintain a portion of the public right-of-way for **one (1) awning(s)** for **LINKS TO LEARNING CHILD CARE**, adjacent to the premises known as **8515 S. Stony Island Ave.**.

Dear Alderman **Michelle A. Harris**:

The applicant referenced above has requested the use of the public right-of-way for a **awning(s)**. An ordinance has been prepared by the Department of Business Affairs and Consumer Protection – Small Business Center - Public Way Use Unit for presentation to the City Council. Because this request was made for properties located in your ward, as approved by you as per the attached, I respectfully request that you introduce the attached ordinance at the next City Council meeting.

If you have any questions regarding this ordinance, please contact Anthony Bertuca at (312) 744-5506.

Department of Business Affairs and Consumer Protection



City of Chicago



O2014-4363

Office of the City Clerk

Document Tracking Sheet

| | |
|---------------------------------|--|
| Meeting Date: | 5/28/2014 |
| Sponsor(s): | Harris (8) |
| Type: | Ordinance |
| Title: | Awning(s) for Woodard Building, Inc. |
| Committee(s) Assignment: | Committee on Transportation and Public Way |

ORDINANCE
WOODARD BUILDING, INC
Acct. No. 342281 - 1
Permit No. 1112861

Be It Ordained by the City Council of the City of Chicago:

SECTION 1. Permission and authority are hereby given and granted to WOODARD BUILDING, INC, upon the terms and subject to the conditions of this ordinance to maintain and use, as now constructed, nine (9) Awning(s) projecting over the public right-of-way adjacent to its premises known as 7850 S. Jeffery Blvd..

Said Awning(s) at S. Jeffery measure(s):

One (1) at five point eight three (5.83) feet in length, and one point nine one (1.91) foot in width for a total of eleven point one four (11.14) square feet.

Said Awning(s) at S. Jeffery measure(s):

One (1) at twelve point seven five (12.75) feet in length, and one point nine one (1.91) foot in width for a total of twenty-four point three five (24.35) square feet.

Said Awning(s) at S. Jeffery measure(s):

One (1) at twelve point five eight (12.58) feet in length, and one point nine one (1.91) foot in width for a total of twenty-four point zero three (24.03) square feet.

Said Awning(s) at S. Jeffery measure(s):

One (1) at thirteen (13) feet in length, and one point nine one (1.91) foot in width for a total of twenty-four point eight three (24.83) square feet.

Said Awning(s) at S. Jeffery measure(s):

One (1) at twenty-six (26) feet in length, and one point nine one (1.91) foot in width for a total of forty-nine point six six (49.66) square feet.

Said Awning(s) at S. Jeffery measure(s):

One (1) at twenty-four point three three (24.33) feet in length, and one point nine one (1.91) foot in width for a total of forty-six point four seven (46.47) square feet.

Said Awning(s) at S. Jeffery measure(s):

One (1) at twenty-four point zero eight (24.08) feet in length, and one point nine one (1.91) foot in width for a total of forty-five point nine nine (45.99) square feet.

Said Awning(s) at S. Jeffery measure(s):

One (1) at sixteen point three three (16.33) feet in length, and one point nine one (1.91) foot in width for a total of thirty-one point one nine (31.19) square feet.

Said Awning(s) at S. Jeffery measure(s):

One (1) at twelve point five eight (12.58) feet in length, and one point nine one (1.91) foot in width for a total of twenty-four point zero three (24.03) square feet.

The location of said privilege shall be as shown on prints kept on file with the Department of Business Affairs and Consumer Protection and the Office of the City Clerk.

Said privilege shall be constructed in accordance with plans and specifications approved by the Zoning Department - Signs.

This grant of privilege in the public way shall be subject to the provisions of Section 10-28-015 and all other required provisions of the Municipal Code of Chicago.

The grantee shall pay to the City of Chicago as compensation for the privilege #1112861 herein granted the sum of one hundred seventy-five (\$175.00) per annum in advance.

A 25% penalty will be added for payments received after due date.

The permit holder agrees to hold the City of Chicago harmless for any damage, relocation or replacement costs associated with damage, relocation or removal of private property caused by the City performing work in the public way.

Authority herein given and granted for a period of five (5) years from and after 05/13/2014.

Alderman 

Michelle A. Harris 8th Ward

7850 S. JEFFERY BLVD

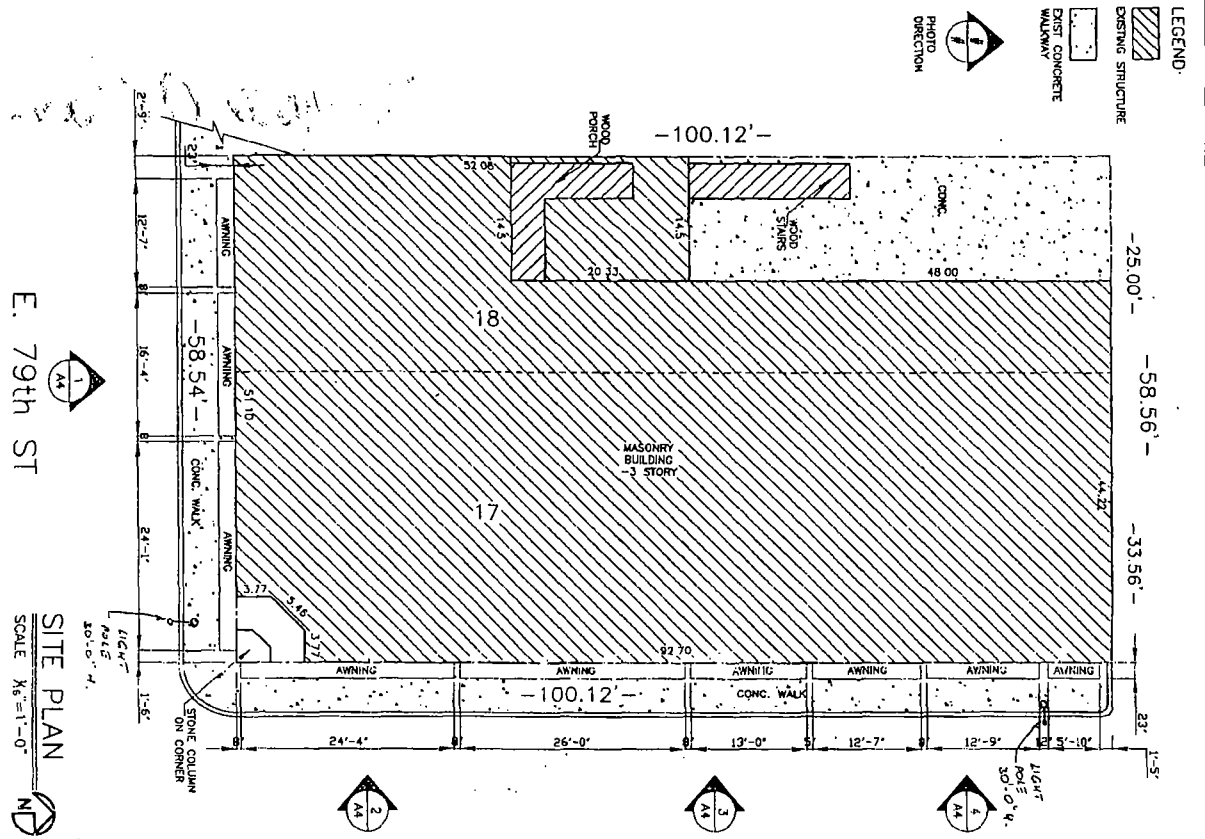

SITE PLAN
SCALE: 1/8" = 1'-0"

LEGEND

- EXISTING STRUCTURE
- EXISTING CONCRETE
- WALKWAY
- PHOTO DIRECTION

| GENERAL BUILDING REQUIREMENTS FOR CHICAGO ZONING ORDINANCE (CZO) AND CHICAGO BUILDING CODE (CBC) 7850 BLVD | | | | |
|--|---------------------------------|-------------------|-----------------------|-------------|
| ITEM | ISSUE | CHAPTER / ARTICLE | Ordinance Requirement | Requirement |
| ZONING REQUIREMENTS | | | | |
| 1.01 | Zoning District | MWP | 33-2 | EXISTING |
| 1.02 | Lot Area | 17-20003-B | 400 SF | EXISTING |
| 1.03 | Maximum Floor Area Ratio | 17-20003-A | 3.0 | EXISTING |
| 1.04 | Total Building Area | | 5,882.02 | EXISTING |
| 1.05 | Maximum Height - No. of Stories | 17-20011-A | 3 | EXISTING |
| 1.06 | Front Setback | 17-20003-B | 0 | EXISTING |
| 1.07 | Side Setback | 17-20003-B | 0 | EXISTING |
| 1.08 | Rear Setback | 17-20003-B | 0 | EXISTING |
| 1.09 | Side Street Setback | 17-20003-B | 0 | EXISTING |
| BUILDING REQUIREMENTS | | | | |
| 2.01 | Occupancy Classification (A) | 313-566(A) | Class A-1 | |
| 2.02 | Type of Construction | 613-600(B) | Type II-B | |
| STRUCTURAL | | | | |
| 1 | Floor loads | 18 (133-206) | 10.0 LL, 100 | |
| 2 | Foundations | 6 (133-206B) | 3,200 pd | |
| 3 | Concrete Construction | 19 (133-207) | 3,200 pd @ 28 days | |
| 4 | Masonry Construction | 21 (133-209) | N/A | |
| 5 | Wood Construction | 23 (133-210) | Grade stamps required | |
| NO VENTILATION, REFRIGERATION, PUMPS, ELECTRICAL | | | | |

- INDEX OF DRAWINGS:**
- A1 - CODE MATRIX & SITE PLAN
 - A2 - EAST ELEVATION
 - A3 - SOUTH ELEVATION
 - A4 - PICTURES

OWNER:
7850 S. JEFFERY BLVD
CHICAGO, IL

EDWARD R. BILITE
REGISTERED ARCHITECT
STATE OF ILLINOIS
C1 - 0219

ENERGY CODE COMPLIANCE
I CERTIFY THAT I AM A REGISTERED ENERGY PROFESSIONAL AND THAT TO THE BEST OF MY PROFESSIONAL KNOWLEDGE AND BELIEF THE ATTACHED PLANS DO NOT VIOLATE ENERGY CODES. I HAVE REVIEWED THE PROJECT FOR ENERGY CODE COMPLIANCE AND THE PROJECT IS AN OPEN SPACE WITH A SHARED SPACE.

CERTIFICATION STATEMENT
I, ARCHITECT, CERTIFY THAT THESE PLANS WERE PREPARED UNDER MY DIRECT SUPERVISION AND TO THE BEST OF MY PROFESSIONAL KNOWLEDGE AND BELIEF THEY COMPLY WITH ALL APPLICABLE ORDINANCES AND CODES OF THE CITY OF CHICAGO AND STATE OF ILLINOIS.

SIGNED: *[Signature]* DATE: _____
JC EXP DATE: 11-30-10



City of Chicago



O2014-4366

Office of the City Clerk

Document Tracking Sheet

| | |
|---------------------------------|--|
| Meeting Date: | 5/28/2014 |
| Sponsor(s): | Pope (10) |
| Type: | Ordinance |
| Title: | Awning(s) for Ramon Reyes |
| Committee(s) Assignment: | Committee on Transportation and Public Way |

ORDINANCE
Ramon Reyes
Acct. No. 299865 - 1
Permit No. 1112988

Be It Ordained by the City Council of the City of Chicago:

SECTION 1. Permission and authority are hereby given and granted to Ramon Reyes, upon the terms and subject to the conditions of this ordinance to maintain and use, as now constructed, two (2) Awning(s) projecting over the public right-of-way adjacent to its premises known as 4011 E. 106th St..

Said Awning(s) at E. 106th St. measure(s):

One (1) at thirty-two (32) feet in length, and two (2) feet in width for a total of sixty-four (64) square feet.

Said Awning(s) at E. 106th St. measure(s):

One (1) at thirty-two (32) feet in length, and two (2) feet in width for a total of sixty-four (64) square feet.

The location of said privilege shall be as shown on prints kept on file with the Department of Business Affairs and Consumer Protection and the Office of the City Clerk.

Said privilege shall be constructed in accordance with plans and specifications approved by the Zoning Department - Signs.

This grant of privilege in the public way shall be subject to the provisions of Section 10-28-015 and all other required provisions of the Municipal Code of Chicago.

The grantee shall pay to the City of Chicago as compensation for the privilege #1112988 herein granted the sum of one hundred fourteen (\$114.00) per annum in advance.

A 25% penalty will be added for payments received after due date.

The permit holder agrees to hold the City of Chicago harmless for any damage, relocation or replacement costs associated with damage, relocation or removal of private property caused by the City performing work in the public way.

Authority herein given and granted for a period of five (5) years from and after 03/01/2014.

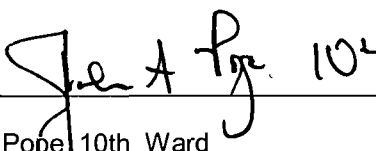
Alderman  10th
John Pope 10th Ward

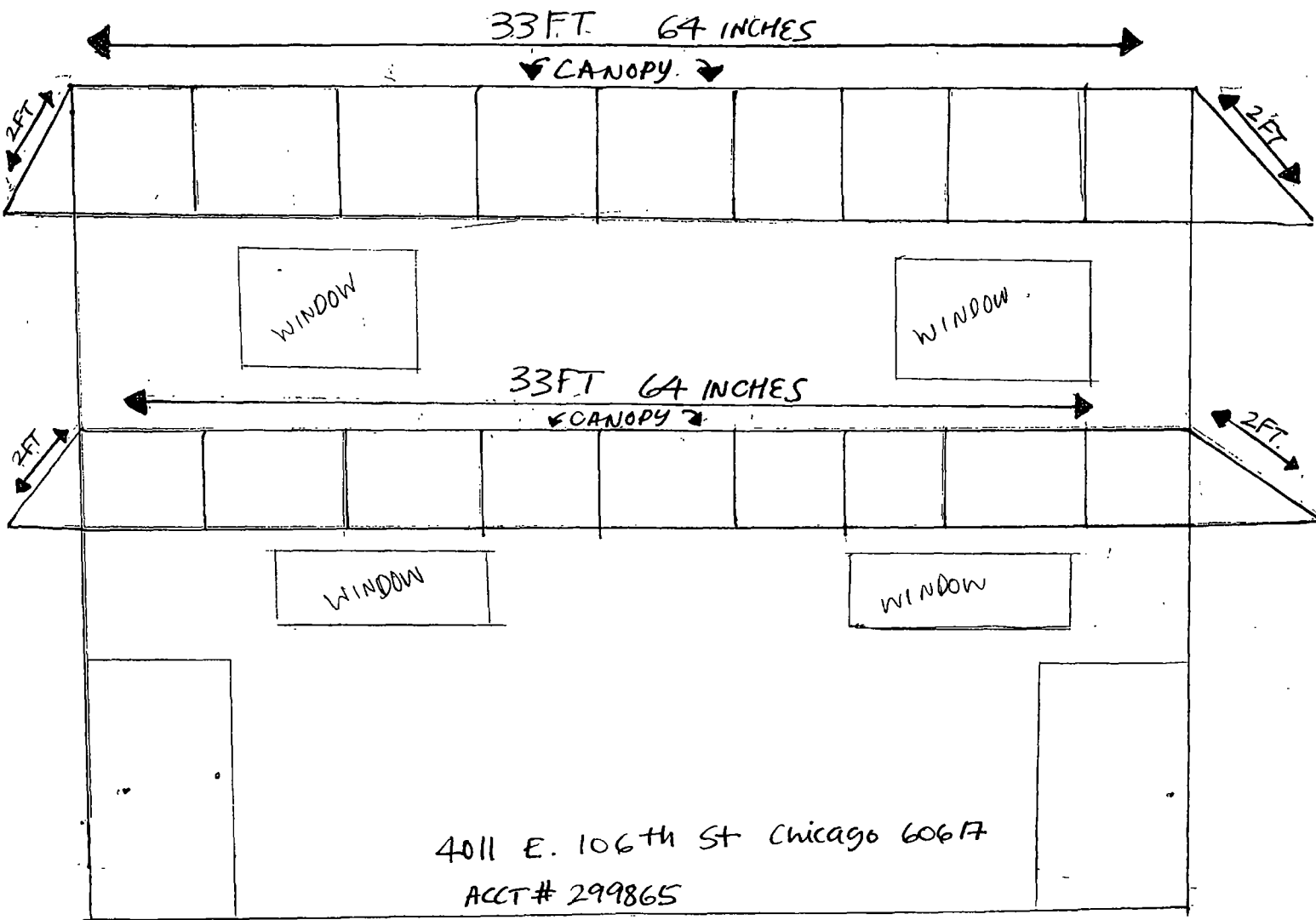

4011 E. 106th St Chicago 60617
ACCT# 299865



05/28/2014

Alderman **John Pope**
Ward # **10**
City of Chicago
City Hall, Room **300**
121 North LaSalle Street
Chicago, Illinois 60602

Re: An ordinance to use and maintain a portion of the public right-of-way for **two (2) awning(s)** for **Ramon Reyes**, adjacent to the premises known as **4011 E. 106th St.**

Dear Alderman **John Pope**:

The applicant referenced above has requested the use of the public right-of-way for a **awning(s)**. An ordinance has been prepared by the Department of Business Affairs and Consumer Protection – Small Business Center - Public Way Use Unit for presentation to the City Council. Because this request was made for properties located in your ward, as approved by you as per the attached, I respectfully request that you introduce the attached ordinance at the next City Council meeting.

If you have any questions regarding this ordinance, please contact Anthony Bertuca at (312) 744-5506.

Department of Business Affairs and Consumer Protection



City of Chicago



O2014-4370

Office of the City Clerk

Document Tracking Sheet

| | |
|---------------------------------|--|
| Meeting Date: | 5/28/2014 |
| Sponsor(s): | Balcer (11) |
| Type: | Ordinance |
| Title: | Awning(s) for Archer Cafe |
| Committee(s) Assignment: | Committee on Transportation and Public Way |

ORDINANCE
ARCHER CAFE
Acct. No. 382285 - 1
Permit No. 1107312

Be It Ordained by the City Council of the City of Chicago:

SECTION 1. Permission and authority are hereby given and granted to ARCHER CAFE, upon the terms and subject to the conditions of this ordinance to construct, install, maintain and use one (1) Awning(s) projecting over the public right-of-way adjacent to its premises known as 2951 S. Archer Ave..

Said Awning(s) at S ARCHER AVE measure(s):

One (1) at twenty (20) feet in length, and two (2) feet in width for a total of forty (40) square feet.

The location of said privilege shall be as shown on prints kept on file with the Department of Business Affairs and Consumer Protection and the Office of the City Clerk.

Said privilege shall be constructed in accordance with plans and specifications approved by the Zoning Department - Signs.

This grant of privilege in the public way shall be subject to the provisions of Section 10-28-015 and all other required provisions of the Municipal Code of Chicago.

The grantee shall pay to the City of Chicago as compensation for the privilege #1107312 herein granted the sum of fifty (\$50.00) per annum in advance.

A 25% penalty will be added for payments received after due date.

The permit holder agrees to hold the City of Chicago harmless for any damage, relocation or replacement costs associated with damage, relocation or removal of private property caused by the City performing work in the public way.

Authority herein given and granted for a period of five (5) years from and after Date of Passage.

Alderman James A. Balcer
James A. Balcer 11th Ward

AWNING SIGN

2951 20ft 36" Projection: 24"

EXITING FACADE

SIDE VIEW

ZONING:
B3-2

Allowed Sign Area: 4 X 22' (Streetfrontage) = 88 SQF
Totral Sign Area: 3 X 20' (Streetfrontage) = 60 SQF

(Bridgeport)
Chicago, IL

3401 S. Halsted St.
Chicago, IL 60608
773-847-2828
Fax 773-847-0088

Archer Cafe
SIGN ELEVATION EXHIBIT

Address: 2951 S. Archer
City: Chicago, IL
State: IL
Account Rep: K. WONG
Sales Rep: K. WONG

APPROVALS
CLIENT: _____
DESIGN: _____
PROJ: _____
Designer: K. WONG
Design No: _____
DATE: 05-20-13
Rev Date: _____

The purchaser agrees to hold the seller harmless against any cause for action for damage which may occur as a result of ordinary wear and tear, including, but not limited to, severe gas leaks in any underground conditions when the purchaser or others may remove the sign.

SPECIFICATIONS

- Awning Fabric Material
- 1" X 1" SQUARE TUBE FRAME
- 3/16" GALVANIZED STEEL Z-CLIP ATTACHMENT
- APPROPRIATE NON-CORROSIVE WALL FASTENER SEE MOUNTING OPTION DETAILS
- #12 TEK SCREW

COLOR SCHEDULE
White
R-176 Red

MOUNTING DETAIL
In-Bolt Mounting
Hanger Bolts
Reverse Toggle Bolt Mounting
Masonry Lag Bolt Mounting

Z-CLIP FOR INSTALLATION EVERY FOUR SIDED

THIS DESIGN AND ENGINEERING IS SUBMITTED AS OUR PROPOSAL, AND THE RIGHT TO USE OR REPRODUCE IN ANY FORM, IS NOT AUTHORIZED WITHOUT WRITTEN PERMISSION BY MONSiBIC, INC.



05/28/2014

Alderman **James A. Balcer**
Ward # 11
City of Chicago
City Hall, Room 203
121 North LaSalle Street
Chicago, Illinois 60602

Re: An ordinance to use and maintain a portion of the public right-of-way for **one (1) awning(s)** for **ARCHER CAFE**, adjacent to the premises known as **2951 S. Archer Ave.**

Dear Alderman **James A. Balcer**:

The applicant referenced above has requested the use of the public right-of-way for a **awning(s)**. An ordinance has been prepared by the Department of Business Affairs and Consumer Protection – Small Business Center - Public Way Use Unit for presentation to the City Council. Because this request was made for properties located in your ward, as approved by you as per the attached, I respectfully request that you introduce the attached ordinance at the next City Council meeting.

If you have any questions regarding this ordinance, please contact Anthony Bertuca at (312) 744-5506.

Department of Business Affairs and Consumer Protection



City of Chicago



O2014-4378

Office of the City Clerk

Document Tracking Sheet

| | |
|---------------------------------|---|
| Meeting Date: | 5/28/2014 |
| Sponsor(s): | Cardenas (12) |
| Type: | Ordinance |
| Title: | Awning(s) for Village Discount Outlet, Inc. |
| Committee(s) Assignment: | Committee on Transportation and Public Way |

ORDINANCE
VILLAGE DISCOUNT OUTLET INC
Acct. No. 85328 - 4
Permit No. 1113038

Be It Ordained by the City Council of the City of Chicago:

SECTION 1. Permission and authority are hereby given and granted to VILLAGE DISCOUNT OUTLET INC, upon the terms and subject to the conditions of this ordinance to maintain and use, as now constructed, one (1) Awning(s) projecting over the public right-of-way adjacent to its premises known as 2514 W. 47th St..

Said Awning(s) at W. 47TH ST measure(s):

One (1) at ninety-three point two five (93.25) feet in length, and two (2) feet in width for a total of one hundred eighty-six point five (186.5) square feet.

The location of said privilege shall be as shown on prints kept on file with the Department of Business Affairs and Consumer Protection and the Office of the City Clerk.

Said privilege shall be constructed in accordance with plans and specifications approved by the Zoning Department - Signs.

This grant of privilege in the public way shall be subject to the provisions of Section 10-28-015 and all other required provisions of the Municipal Code of Chicago.

The grantee shall pay to the City of Chicago as compensation for the privilege #1113038 herein granted the sum of one hundred eighteen dollars and twenty-five cents (\$118.25) per annum in advance.

A 25% penalty will be added for payments received after due date.

The permit holder agrees to hold the City of Chicago harmless for any damage, relocation or replacement costs associated with damage, relocation or removal of private property caused by the City performing work in the public way.

Authority herein given and granted for a period of five (5) years from and after 03/18/2014.

Alderman _____

George Cardenas 12th Ward

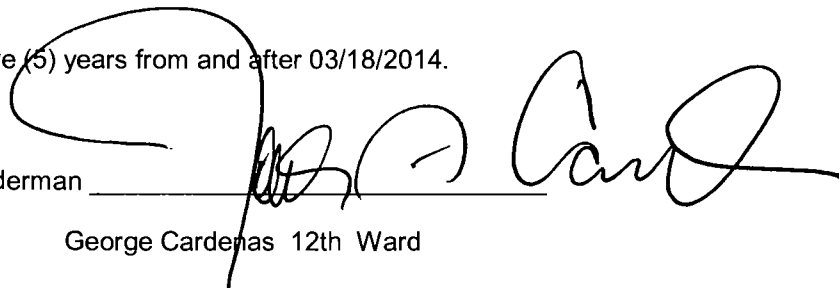

PAGE 01

MAINT. DEPT.

11/05/2008 12:09 1/093884/2385

11/05/2008 12:09 1/093884/2385

SIDE VIEW

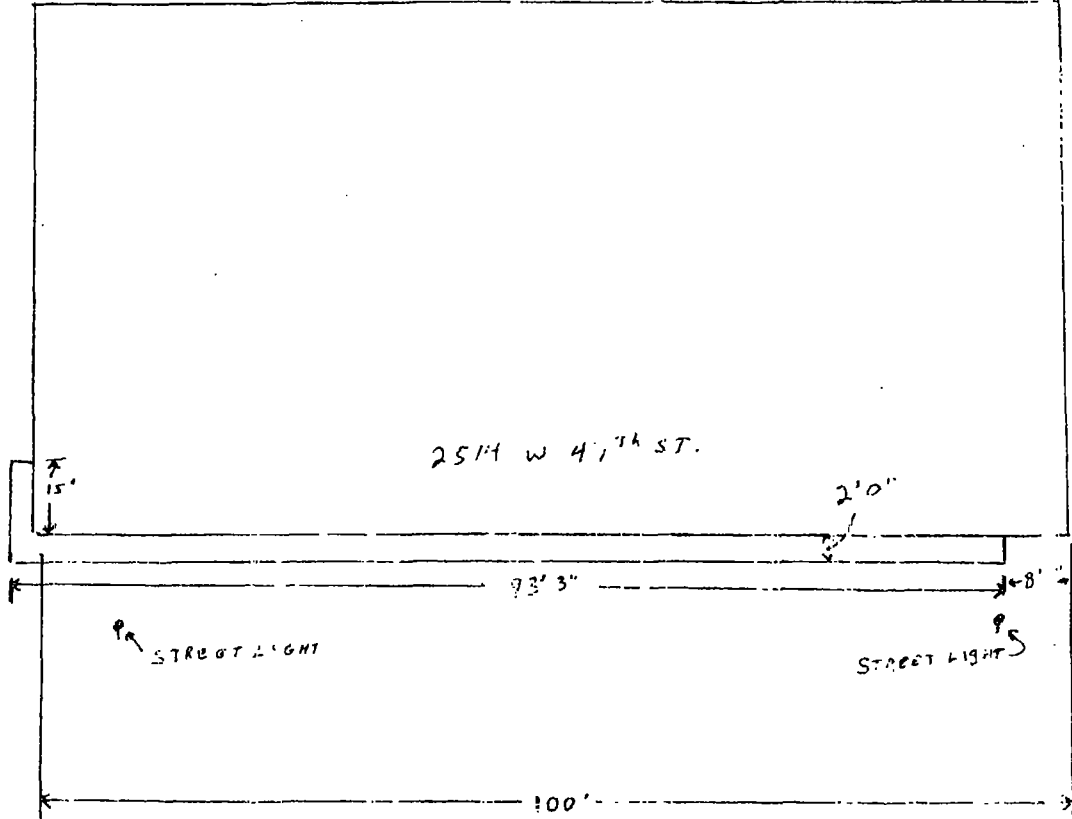
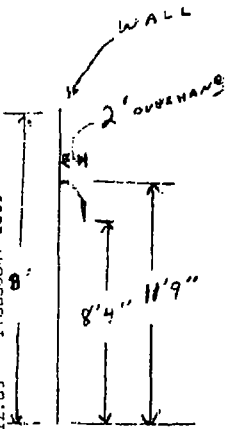



05/28/2014

Alderman **George Cardenas**
Ward # **12**
City of Chicago
City Hall, Room **203**
121 North LaSalle Street
Chicago, Illinois 60602

Re: An ordinance to use and maintain a portion of the public right-of-way for **one (1) awning(s)** for
VILLAGE DISCOUNT OUTLET INC, adjacent to the premises known as **2514 W. 47th St.**

Dear Alderman **George Cardenas**:

The applicant referenced above has requested the use of the public right-of-way for a **awning(s)**. An ordinance has been prepared by the Department of Business Affairs and Consumer Protection – Small Business Center - Public Way Use Unit for presentation to the City Council. Because this request was made for properties located in your ward, as approved by you as per the attached, I respectfully request that you introduce the attached ordinance at the next City Council meeting.

If you have any questions regarding this ordinance, please contact Anthony Bertuca at (312) 744-5506.

Department of Business Affairs and Consumer Protection



City of Chicago



O2014-4384

Office of the City Clerk

Document Tracking Sheet

| | |
|---------------------------------|--|
| Meeting Date: | 5/28/2014 |
| Sponsor(s): | Burke (14) |
| Type: | Ordinance |
| Title: | Awning(s) for Doctor's Office |
| Committee(s) Assignment: | Committee on Transportation and Public Way |

ORDINANCE
DOCTOR'S OFFICE
Acct. No. 388312 - 1
Permit No. 1111185

Be It Ordained by the City Council of the City of Chicago:

SECTION 1. Permission and authority are hereby given and granted to DOCTOR'S OFFICE, upon the terms and subject to the conditions of this ordinance to construct, install, maintain and use one (1) Awning(s) projecting over the public right-of-way adjacent to its premises known as 2645 W. 51st St..

Said Awning(s) at W 51ST ST measure(s):

One (1) at twenty-four (24) feet in length, and two (2) feet in width for a total of forty-eight (48) square feet.

The location of said privilege shall be as shown on prints kept on file with the Department of Business Affairs and Consumer Protection and the Office of the City Clerk.

Said privilege shall be constructed in accordance with plans and specifications approved by the Zoning Department - Signs.

This grant of privilege in the public way shall be subject to the provisions of Section 10-28-015 and all other required provisions of the Municipal Code of Chicago.

The grantee shall pay to the City of Chicago as compensation for the privilege #1111185 herein granted the sum of fifty (\$50.00) per annum in advance.

A 25% penalty will be added for payments received after due date.

The permit holder agrees to hold the City of Chicago harmless for any damage, relocation or replacement costs associated with damage, relocation or removal of private property caused by the City performing work in the public way.

Authority herein given and granted for a period of five (5) years from and after Date of Passage.

Alderman

Edward M. Burke 14th Ward





05/28/2014

Alderman **Edward M. Burke**
Ward # **14**
City of Chicago
City Hall, Room **302**
121 North LaSalle Street
Chicago, Illinois 60602

Re: An ordinance to use and maintain a portion of the public right-of-way for **one (1) awning(s)** for **DOCTOR'S OFFICE**, adjacent to the premises known as **2645 W. 51st St.**

Dear Alderman **Edward M. Burke**:

The applicant referenced above has requested the use of the public right-of-way for a **awning(s)**. An ordinance has been prepared by the Department of Business Affairs and Consumer Protection – Small Business Center - Public Way Use Unit for presentation to the City Council. Because this request was made for properties located in your ward, as approved by you as per the attached, I respectfully request that you introduce the attached ordinance at the next City Council meeting.

If you have any questions regarding this ordinance, please contact Anthony Bertuca at (312) 744-5506.

Department of Business Affairs and Consumer Protection



City of Chicago

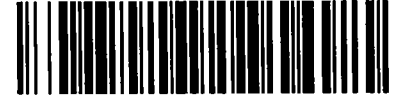

O2014-4392

Office of the City Clerk

Document Tracking Sheet

| | |
|---------------------------------|--|
| Meeting Date: | 5/28/2014 |
| Sponsor(s): | Burke (14) |
| Type: | Ordinance |
| Title: | Awning(s) for Marin Funeral Home |
| Committee(s) Assignment: | Committee on Transportation and Public Way |

ORDINANCE
MARIN FUNERAL HOME
Acct. No. 65617 - 4
Permit No. 1113008

Be It Ordained by the City Council of the City of Chicago:

SECTION 1. Permission and authority are hereby given and granted to MARIN FUNERAL HOME, upon the terms and subject to the conditions of this ordinance to maintain and use, as now constructed, one (1) Awning(s) projecting over the public right-of-way adjacent to its premises known as 2744 W. 51st St..

Said Awning(s) at W. 51st Street measure(s):

One (1) at twelve (12) feet in length, and seven point seven five (7.75) feet in width for a total of ninety-three (93) square feet.

The location of said privilege shall be as shown on prints kept on file with the Department of Business Affairs and Consumer Protection and the Office of the City Clerk.

Said privilege shall be constructed in accordance with plans and specifications approved by the Zoning Department - Signs.

This grant of privilege in the public way shall be subject to the provisions of Section 10-28-015 and all other required provisions of the Municipal Code of Chicago.

The grantee shall pay to the City of Chicago as compensation for the privilege #1113008 herein granted the sum of fifty (\$50.00) per annum in advance.

A 25% penalty will be added for payments received after due date.

The permit holder agrees to hold the City of Chicago harmless for any damage, relocation or replacement costs associated with damage, relocation or removal of private property caused by the City performing work in the public way.

Authority herein given and granted for a period of five (5) years from and after 03/18/2014.

Alderman

Edward M. Burke 14th Ward





05/28/2014

Alderman **Edward M. Burke**
Ward # 14
City of Chicago
City Hall, Room 302
121 North LaSalle Street
Chicago, Illinois 60602

Re: An ordinance to use and maintain a portion of the public right-of-way for **one (1) awning(s)** for **MARIN FUNERAL HOME**, adjacent to the premises known as **2744 W. 51st St.**

Dear Alderman **Edward M. Burke**:

The applicant referenced above has requested the use of the public right-of-way for a **awning(s)**. An ordinance has been prepared by the Department of Business Affairs and Consumer Protection – Small Business Center - Public Way Use Unit for presentation to the City Council. Because this request was made for properties located in your ward, as approved by you as per the attached, I respectfully request that you introduce the attached ordinance at the next City Council meeting.

If you have any questions regarding this ordinance, please contact Anthony Bertuca at (312) 744-5506.

Department of Business Affairs and Consumer Protection



City of Chicago



O2014-4399

Office of the City Clerk

Document Tracking Sheet

| | |
|---------------------------------|--|
| Meeting Date: | 5/28/2014 |
| Sponsor(s): | Thomas (17) |
| Type: | Ordinance |
| Title: | Awning(s) for Tina's Cocktail Lounge |
| Committee(s) Assignment: | Committee on Transportation and Public Way |

ORDINANCE
TINA'S COCKTAIL LOUNGE
Acct. No. 63099 - 1
Permit No. 1110336

Be It Ordained by the City Council of the City of Chicago:

SECTION 1. Permission and authority are hereby given and granted to TINA'S COCKTAIL LOUNGE, upon the terms and subject to the conditions of this ordinance to maintain and use, as now constructed, one (1) Awning(s) projecting over the public right-of-way adjacent to its premises known as 7840-42 S. Racine Ave..

Said Awning(s) at S. RACINE measure(s):

One (1) at forty-seven (47) feet in length, and three (3) feet in width for a total of one hundred forty-one (141) square feet.

The location of said privilege shall be as shown on prints kept on file with the Department of Business Affairs and Consumer Protection and the Office of the City Clerk.

Said privilege shall be constructed in accordance with plans and specifications approved by the Zoning Department - Signs.

This grant of privilege in the public way shall be subject to the provisions of Section 10-28-015 and all other required provisions of the Municipal Code of Chicago.

The grantee shall pay to the City of Chicago as compensation for the privilege #1110336 herein granted the sum of seventy-two (\$72.00) per annum in advance.

A 25% penalty will be added for payments received after due date.

The permit holder agrees to hold the City of Chicago harmless for any damage, relocation or replacement costs associated with damage, relocation or removal of private property caused by the City performing work in the public way.

Authority herein given and granted for a period of five (5) years from and after 01/13/2014.

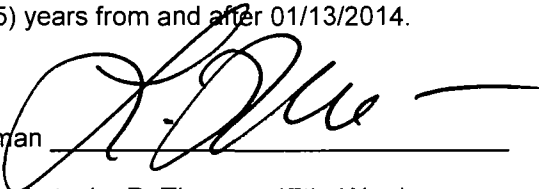
Alderman 

Latasha R. Thomas 17th Ward



20293230060000 02/27/2007



City of Chicago



O2014-4406

Office of the City Clerk

Document Tracking Sheet

| | |
|---------------------------------|--|
| Meeting Date: | 5/28/2014 |
| Sponsor(s): | O'Shea (19) |
| Type: | Ordinance |
| Title: | Awning(s) for Djenne Collection |
| Committee(s) Assignment: | Committee on Transportation and Public Way |

ORDINANCE
DJENNE COLLECTION
Acct. No. 59980 - 3
Permit No. 1112995

Be It Ordained by the City Council of the City of Chicago:

SECTION 1. Permission and authority are hereby given and granted to DJENNE COLLECTION, upon the terms and subject to the conditions of this ordinance to maintain and use, as now constructed, one (1) Awning(s) projecting over the public right-of-way adjacent to its premises known as 1759 W. 95th St..

Said Awning(s) at W. 95th Street measure(s):

One (1) at twenty-four (24) feet in length, and two point one seven (2.17) feet in width for a total of fifty-two point zero eight (52.08) square feet.

The location of said privilege shall be as shown on prints kept on file with the Department of Business Affairs and Consumer Protection and the Office of the City Clerk.

Said privilege shall be constructed in accordance with plans and specifications approved by the Zoning Department - Signs.

This grant of privilege in the public way shall be subject to the provisions of Section 10-28-015 and all other required provisions of the Municipal Code of Chicago.

The grantee shall pay to the City of Chicago as compensation for the privilege #1112995 herein granted the sum of fifty (\$50.00) per annum in advance.

A 25% penalty will be added for payments received after due date.

The permit holder agrees to hold the City of Chicago harmless for any damage, relocation or replacement costs associated with damage, relocation or removal of private property caused by the City performing work in the public way.

Authority herein given and granted for a period of five (5) years from and after 01/13/2014.

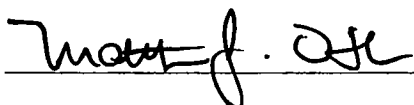
Alderman 
Matthew J. O'Shea 19th Ward

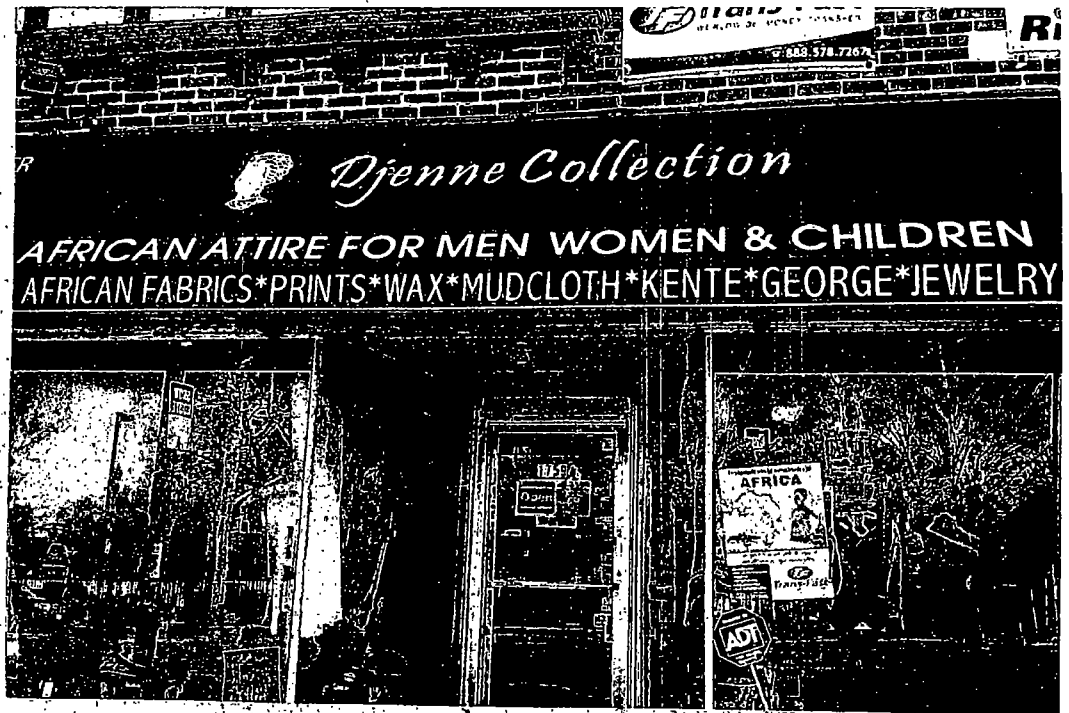



05/28/2014

Alderman **Matthew J. O'Shea**
Ward # **19**
City of Chicago
City Hall, Room **300**
121 North LaSalle Street
Chicago, Illinois 60602

Re: An ordinance to use and maintain a portion of the public right-of-way for **one (1) awning(s)** for **DJENNE COLLECTION**, adjacent to the premises known as **1759 W. 95th St.**

Dear Alderman **Matthew J. O'Shea**:

The applicant referenced above has requested the use of the public right-of-way for a **awning(s)**. An ordinance has been prepared by the Department of Business Affairs and Consumer Protection – Small Business Center - Public Way Use Unit for presentation to the City Council. Because this request was made for properties located in your ward, as approved by you as per the attached, I respectfully request that you introduce the attached ordinance at the next City Council meeting.

If you have any questions regarding this ordinance, please contact Anthony Bertuca at (312) 744-5506.

Department of Business Affairs and Consumer Protection



City of Chicago



O2014-4408

Office of the City Clerk

Document Tracking Sheet

| | |
|---------------------------------|--|
| Meeting Date: | 5/28/2014 |
| Sponsor(s): | O'Shea (19) |
| Type: | Ordinance |
| Title: | Awning(s) for Ellie's |
| Committee(s) Assignment: | Committee on Transportation and Public Way |

ORDINANCE
ELLIE'S
Acct. No. 371175 - 1
Permit No. 1113066

Be It Ordained by the City Council of the City of Chicago:

SECTION 1. Permission and authority are hereby given and granted to ELLIE'S, upon the terms and subject to the conditions of this ordinance to maintain and use, as now constructed, two (2) Awning(s) projecting over the public right-of-way adjacent to its premises known as 10701 S. Hale Ave..

Said Awning(s) at Hale measure(s):

One (1) at twenty-three (23) feet in length, and two point three three (2.33) feet in width for a total of fifty-three point five nine (53.59) square feet.

Said Awning(s) at 107th measure(s):

One (1) at thirteen (13) feet in length, and two point three three (2.33) feet in width for a total of thirty point two nine (30.29) square feet.

The location of said privilege shall be as shown on prints kept on file with the Department of Business Affairs and Consumer Protection and the Office of the City Clerk.

Said privilege shall be constructed in accordance with plans and specifications approved by the Zoning Department - Signs.

This grant of privilege in the public way shall be subject to the provisions of Section 10-28-015 and all other required provisions of the Municipal Code of Chicago.

The grantee shall pay to the City of Chicago as compensation for the privilege #1113066 herein granted the sum of one hundred (\$100.00) per annum in advance.

A 25% penalty will be added for payments received after due date.

The permit holder agrees to hold the City of Chicago harmless for any damage, relocation or replacement costs associated with damage, relocation or removal of private property caused by the City performing work in the public way.

Authority herein given and granted for a period of five (5) years from and after Date of Passage.

Alderman 
Matthew J. O'Shea 19th Ward

WEST SIDE OF BUILDING

10701 S. HALE AVE.
CHGO, IL. 60643

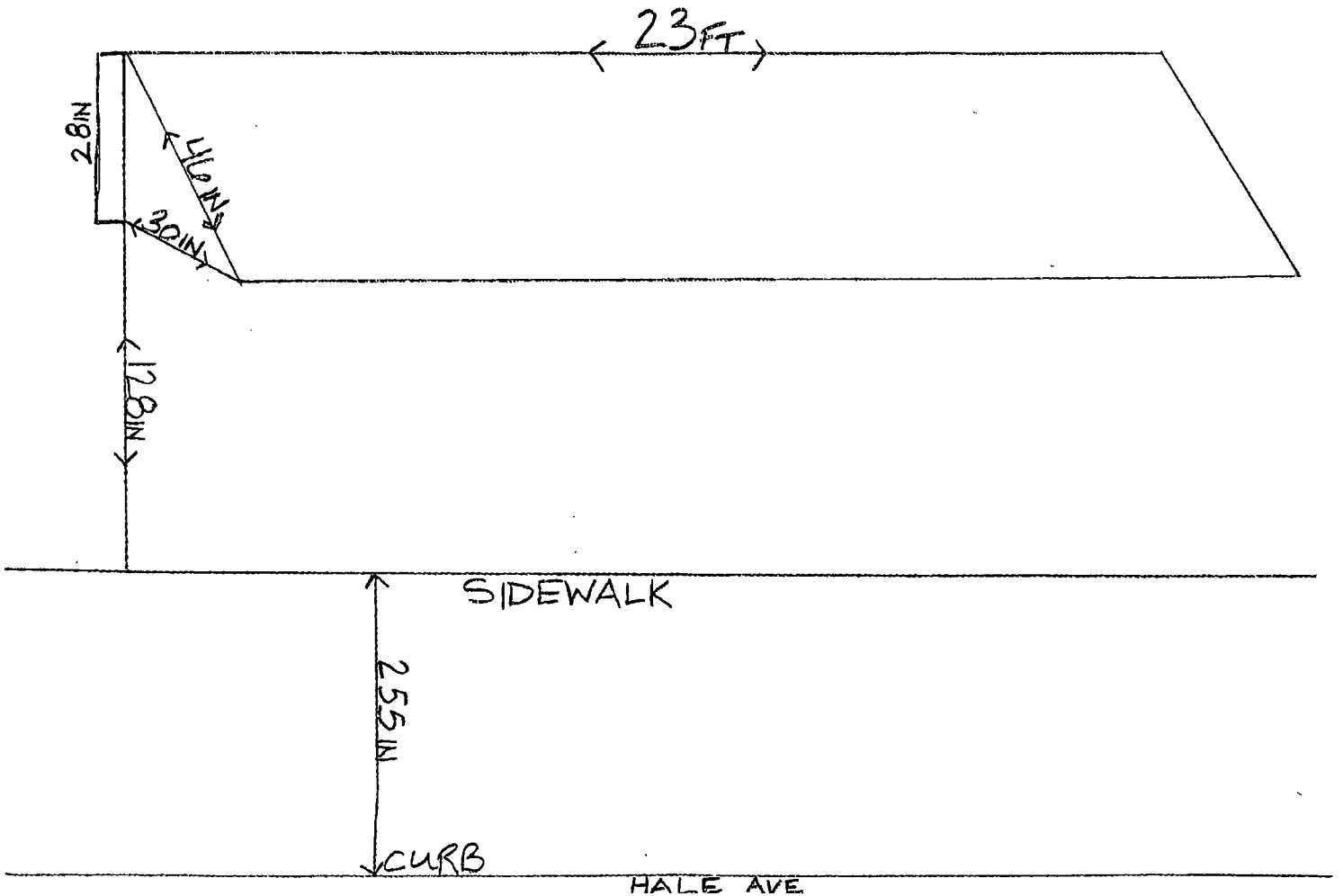



05/28/2014

Alderman **Matthew J. O'Shea**
Ward # **19**
City of Chicago
City Hall, Room **300**
121 North LaSalle Street
Chicago, Illinois 60602

Re: An ordinance to use and maintain a portion of the public right-of-way for **two (2) awning(s)** for **ELLIE'S**, adjacent to the premises known as **10701 S. Hale Ave.**.

Dear Alderman **Matthew J. O'Shea**:

The applicant referenced above has requested the use of the public right-of-way for a **awning(s)**. An ordinance has been prepared by the Department of Business Affairs and Consumer Protection – Small Business Center - Public Way Use Unit for presentation to the City Council. Because this request was made for properties located in your ward, as approved by you as per the attached, I respectfully request that you introduce the attached ordinance at the next City Council meeting.

If you have any questions regarding this ordinance, please contact Anthony Bertuca at (312) 744-5506.

Department of Business Affairs and Consumer Protection



City of Chicago



O2014-4418

Office of the City Clerk

Document Tracking Sheet

| | |
|---------------------------------|---|
| Meeting Date: | 5/28/2014 |
| Sponsor(s): | O'Shea (19) |
| Type: | Ordinance |
| Title: | Awning(s) for HTP Associates Occupation Ltd |
| Committee(s) Assignment: | Committee on Transportation and Public Way |

ORDINANCE
HTP ASSOCIATES OCCUPATION LDT
Acct. No. 300154 - 1
Permit No. 1112362

Be It Ordained by the City Council of the City of Chicago:

SECTION 1. Permission and authority are hereby given and granted to HTP ASSOCIATES OCCUPATION LDT, upon the terms and subject to the conditions of this ordinance to maintain and use, as now constructed, one (1) Awning(s) projecting over the public right-of-way adjacent to its premises known as 11012 S. Western Ave..

Said Awning(s) at S. Western Avenue measure(s):

One (1) at thirty-five (35) feet in length, and two (2) feet in width for a total of seventy (70) square feet.

The location of said privilege shall be as shown on prints kept on file with the Department of Business Affairs and Consumer Protection and the Office of the City Clerk.

Said privilege shall be constructed in accordance with plans and specifications approved by the Zoning Department - Signs.

This grant of privilege in the public way shall be subject to the provisions of Section 10-28-015 and all other required provisions of the Municipal Code of Chicago.

The grantee shall pay to the City of Chicago as compensation for the privilege #1112362 herein granted the sum of sixty (\$60.00) per annum in advance.

A 25% penalty will be added for payments received after due date.

The permit holder agrees to hold the City of Chicago harmless for any damage, relocation or replacement costs associated with damage, relocation or removal of private property caused by the City performing work in the public way.

Authority herein given and granted for a period of five (5) years from and after Date of Passage.

Alderman 
Matthew J. O'Shea 19th Ward

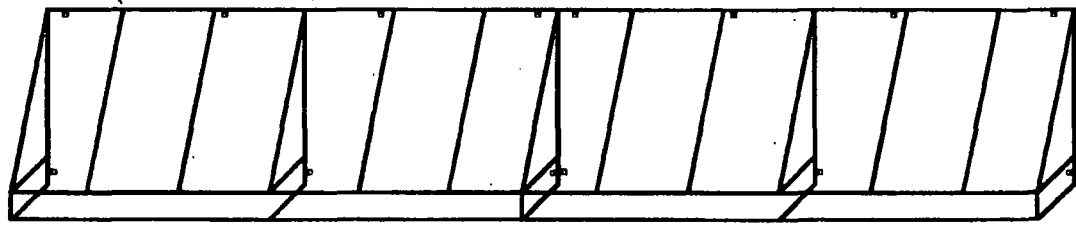
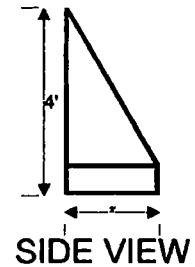
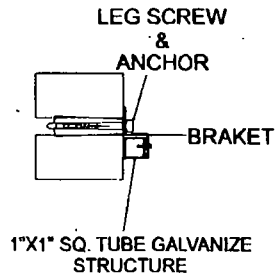
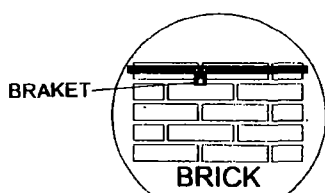

35'
1"X1" SQ. TUBE GALVANIZE STRUCTURE



05/28/2014

Alderman **Matthew J. O'Shea**
Ward # 19
City of Chicago
City Hall, Room 300
121 North LaSalle Street
Chicago, Illinois 60602

Re: An ordinance to use and maintain a portion of the public right-of-way for **one (1) awning(s)** for **HTP ASSOCIATES OCCUPATION LDT**, adjacent to the premises known as **11012 S. Western Ave.**.

Dear Alderman **Matthew J. O'Shea**:

The applicant referenced above has requested the use of the public right-of-way for a **awning(s)**. An ordinance has been prepared by the Department of Business Affairs and Consumer Protection – Small Business Center - Public Way Use Unit for presentation to the City Council. Because this request was made for properties located in your ward, as approved by you as per the attached, I respectfully request that you introduce the attached ordinance at the next City Council meeting.

If you have any questions regarding this ordinance, please contact Anthony Bertuca at (312) 744-5506.

Department of Business Affairs and Consumer Protection



City of Chicago



O2014-4421

Office of the City Clerk

Document Tracking Sheet

| | |
|---------------------------------|--|
| Meeting Date: | 5/28/2014 |
| Sponsor(s): | O'Shea (19) |
| Type: | Ordinance |
| Title: | Awning(s) for Shear Soul, Inc. |
| Committee(s) Assignment: | Committee on Transportation and Public Way |

ORDINANCE
SHEAR SOUL INC
Acct. No. 265825 - 1
Permit No. 1113013

Be It Ordained by the City Council of the City of Chicago:

SECTION 1. Permission and authority are hereby given and granted to SHEAR SOUL INC, upon the terms and subject to the conditions of this ordinance to maintain and use, as now constructed, one (1) Awning(s) projecting over the public right-of-way adjacent to its premises known as 1763 W. 95th St..

Said Awning(s) at W. 95th Street measure(s):

One (1) at twenty-five (25) feet in length, and three (3) feet in width for a total of seventy-five (75) square feet.

The location of said privilege shall be as shown on prints kept on file with the Department of Business Affairs and Consumer Protection and the Office of the City Clerk.

Said privilege shall be constructed in accordance with plans and specifications approved by the Zoning Department - Signs.

This grant of privilege in the public way shall be subject to the provisions of Section 10-28-015 and all other required provisions of the Municipal Code of Chicago.

The grantee shall pay to the City of Chicago as compensation for the privilege #1113013 herein granted the sum of fifty (\$50.00) per annum in advance.

A 25% penalty will be added for payments received after due date.

The permit holder agrees to hold the City of Chicago harmless for any damage, relocation or replacement costs associated with damage, relocation or removal of private property caused by the City performing work in the public way.

Authority herein given and granted for a period of five (5) years from and after 01/13/2014.

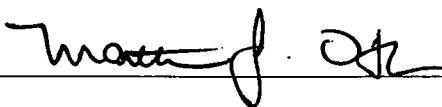
Alderman 
Matthew J. O'Shea 19th Ward

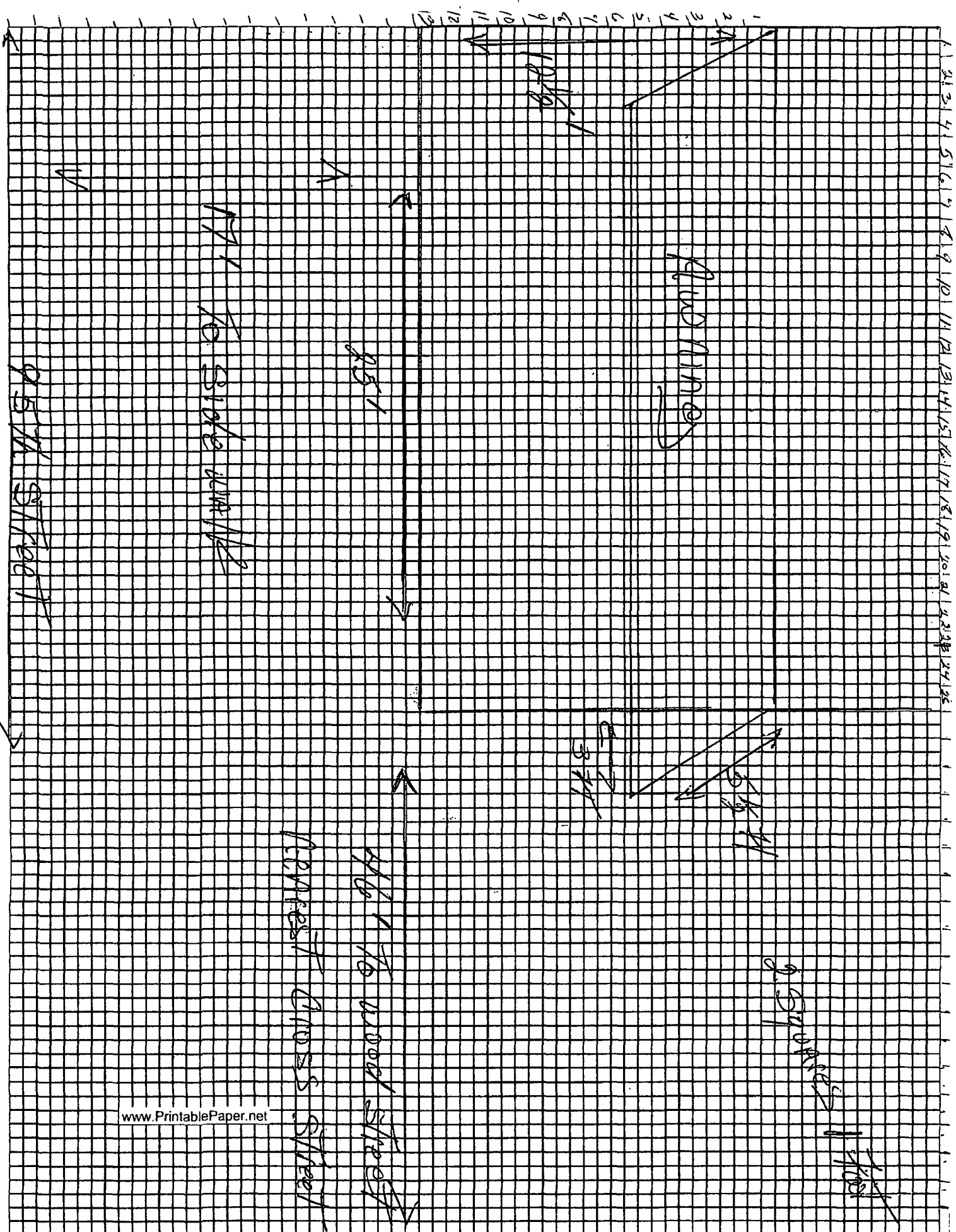



05/28/2014

Alderman **Matthew J. O'Shea**
Ward # **19**
City of Chicago
City Hall, Room **300**
121 North LaSalle Street
Chicago, Illinois 60602

Re: An ordinance to use and maintain a portion of the public right-of-way for **one (1) awning(s)** for **SHEAR SOUL INC**, adjacent to the premises known as **1763 W. 95th St.**.

Dear Alderman **Matthew J. O'Shea**:

The applicant referenced above has requested the use of the public right-of-way for a **awning(s)**. An ordinance has been prepared by the Department of Business Affairs and Consumer Protection – Small Business Center - Public Way Use Unit for presentation to the City Council. Because this request was made for properties located in your ward, as approved by you as per the attached, I respectfully request that you introduce the attached ordinance at the next City Council meeting.

If you have any questions regarding this ordinance, please contact Anthony Bertuca at (312) 744-5506.

Department of Business Affairs and Consumer Protection



City of Chicago



O2014-4431

Office of the City Clerk

Document Tracking Sheet

| | |
|---------------------------------|--|
| Meeting Date: | 5/28/2014 |
| Sponsor(s): | Chandler (24) |
| Type: | Ordinance |
| Title: | Awning(s) for Cellular Zone |
| Committee(s) Assignment: | Committee on Transportation and Public Way |

ORDINANCE
CELLULAR ZONE
Acct. No. 269164 - 1
Permit No. 1110979

Be It Ordained by the City Council of the City of Chicago:

SECTION 1. Permission and authority are hereby given and granted to CELLULAR ZONE, upon the terms and subject to the conditions of this ordinance to maintain and use, as now constructed, one (1) Awning(s) projecting over the public right-of-way adjacent to its premises known as 3206 W. 16th St..

Said Awning(s) at W 16th St measure(s):

One (1) at twenty-eight (28) feet in length, and one point eight three (1.83) foot in width for a total of fifty-one point two four (51.24) square feet.

The location of said privilege shall be as shown on prints kept on file with the Department of Business Affairs and Consumer Protection and the Office of the City Clerk.

Said privilege shall be constructed in accordance with plans and specifications approved by the Zoning Department - Signs.

This grant of privilege in the public way shall be subject to the provisions of Section 10-28-015 and all other required provisions of the Municipal Code of Chicago.

The grantee shall pay to the City of Chicago as compensation for the privilege #1110979 herein granted the sum of fifty-three (\$53.00) per annum in advance.

A 25% penalty will be added for payments received after due date.

The permit holder agrees to hold the City of Chicago harmless for any damage, relocation or replacement costs associated with damage, relocation or removal of private property caused by the City performing work in the public way.

Authority herein given and granted for a period of five (5) years from and after 01/13/2014.

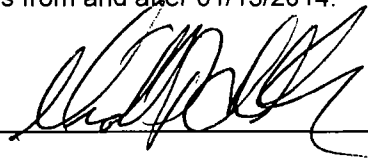
Alderman 
Michael D. Chandler 24th Ward



Account :

269 164-1

3206 W 16th St

Chicago IL 60623



2nd ATTEMPT AT INTRODUCTION

05/28/2014

Alderman **Michael D. Chandler**
Ward # 24
City of Chicago
City Hall, Room 203
121 North LaSalle Street
Chicago, Illinois 60602

Re: An ordinance to use and maintain a portion of the public right-of-way for **one (1) awning(s)** for **CELLULAR ZONE**, adjacent to the premises known as **3206 W. 16th St.**.

Dear Alderman **Michael D. Chandler**:

The applicant referenced above has requested the use of the public right-of-way for a **awning(s)**. An ordinance has been prepared by the Department of Business Affairs and Consumer Protection – Small Business Center - Public Way Use Unit for presentation to the City Council. Because this request was made for properties located in your ward, as approved by you as per the attached, I respectfully request that you introduce the attached ordinance at the next City Council meeting.

If you have any questions regarding this ordinance, please contact Anthony Bertuca at (312) 744-5506.

Department of Business Affairs and Consumer Protection



City of Chicago



O2014-4435

Office of the City Clerk

Document Tracking Sheet

| | |
|---------------------------------|--|
| Meeting Date: | 5/28/2014 |
| Sponsor(s): | Solis (25) |
| Type: | Ordinance |
| Title: | Awning(s) for House of Fortune |
| Committee(s) Assignment: | Committee on Transportation and Public Way |

ORDINANCE
HOUSE OF FORTUNE
Acct. No. 215315 - 1
Permit No. 1113052

Be It Ordained by the City Council of the City of Chicago:

SECTION 1. Permission and authority are hereby given and granted to HOUSE OF FORTUNE, upon the terms and subject to the conditions of this ordinance to maintain and use, as now constructed, one (1) Awning(s) projecting over the public right-of-way adjacent to its premises known as 2405-07 S. Wentworth Ave..

Said Awning(s) at S. Wentworth Ave. measure(s):

One (1) at thirty-eight (38) feet in length, and six (6) feet in width for a total of two hundred twenty-eight (228) square feet.

The location of said privilege shall be as shown on prints kept on file with the Department of Business Affairs and Consumer Protection and the Office of the City Clerk.

Said privilege shall be constructed in accordance with plans and specifications approved by the Zoning Department - Signs.

This grant of privilege in the public way shall be subject to the provisions of Section 10-28-015 and all other required provisions of the Municipal Code of Chicago.

The grantee shall pay to the City of Chicago as compensation for the privilege #1113052 herein granted the sum of sixty-three (\$63.00) per annum in advance.

A 25% penalty will be added for payments received after due date.

The permit holder agrees to hold the City of Chicago harmless for any damage, relocation or replacement costs associated with damage, relocation or removal of private property caused by the City performing work in the public way.

Authority herein given and granted for a period of five (5) years from and after 04/26/2014.

Alderman _____

Daniel S. Solis 25th Ward

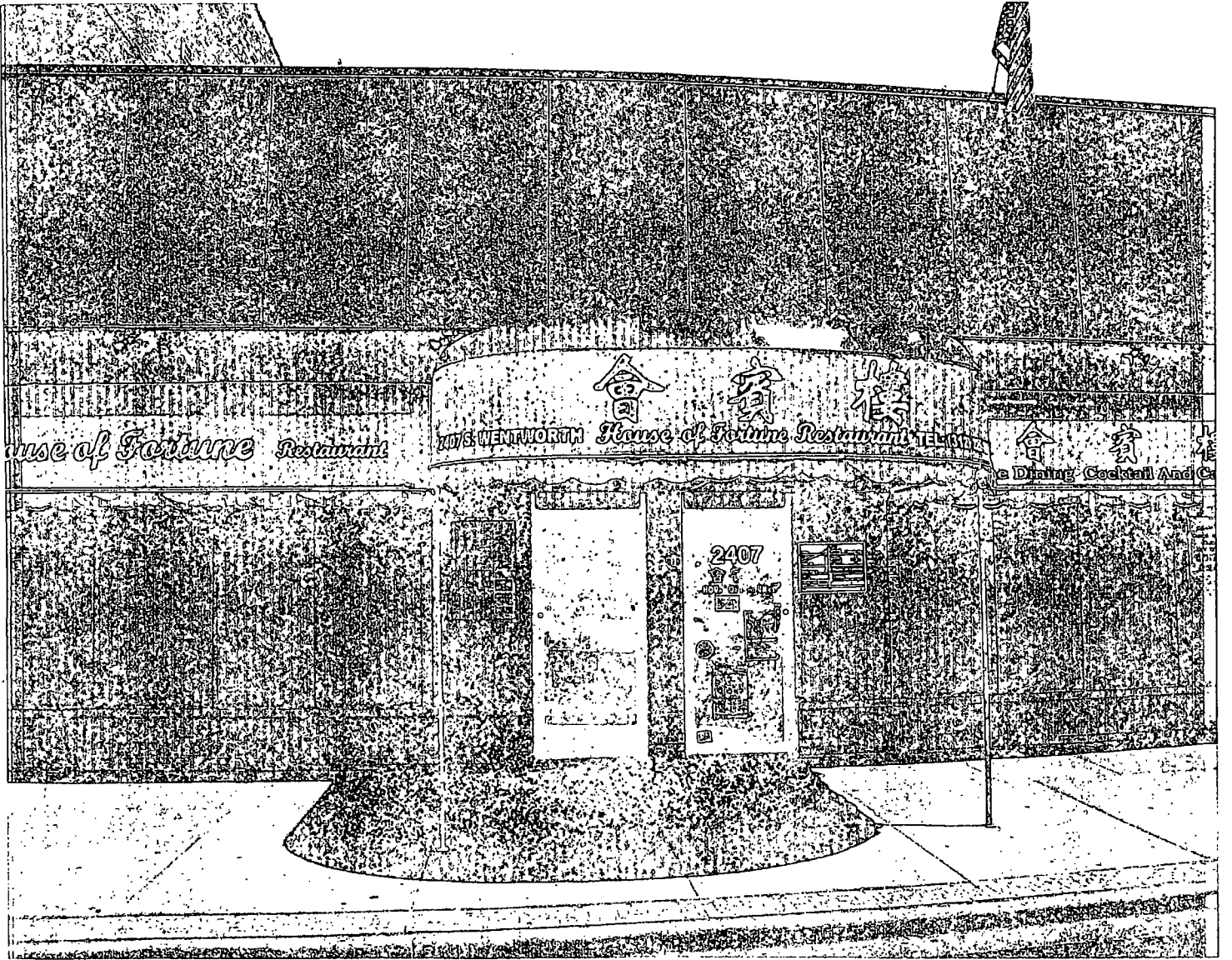



05/28/2014

Alderman **Daniel S. Solis**
Ward # **25**
City of Chicago
City Hall, Room **203**
121 North LaSalle Street
Chicago, Illinois 60602

Re: An ordinance to use and maintain a portion of the public right-of-way for **one (1) awning(s)** for **HOUSE OF FORTUNE**, adjacent to the premises known as **2405-07 S. Wentworth Ave.**.

Dear Alderman **Daniel S. Solis**:

The applicant referenced above has requested the use of the public right-of-way for a **awning(s)**. An ordinance has been prepared by the Department of Business Affairs and Consumer Protection – Small Business Center - Public Way Use Unit for presentation to the City Council. Because this request was made for properties located in your ward, as approved by you as per the attached, I respectfully request that you introduce the attached ordinance at the next City Council meeting.

If you have any questions regarding this ordinance, please contact Anthony Bertuca at (312) 744-5506.

Department of Business Affairs and Consumer Protection



City of Chicago



O2014-4439

Office of the City Clerk

Document Tracking Sheet

| | |
|---------------------------------|--|
| Meeting Date: | 5/28/2014 |
| Sponsor(s): | Maldonado (26) |
| Type: | Ordinance |
| Title: | Awning(s) for Grandma J's, Inc. |
| Committee(s) Assignment: | Committee on Transportation and Public Way |

ORDINANCE
Grandma J's Inc.
Acct. No. 371730 - 1
Permit No. 1102570

Be It Ordained by the City Council of the City of Chicago:

SECTION 1. Permission and authority are hereby given and granted to Grandma J's Inc., upon the terms and subject to the conditions of this ordinance to maintain and use, as now constructed, one (1) Awning(s) projecting over the public right-of-way adjacent to its premises known as 1552 N. Kedzie Ave..

Said Awning(s) at N Damen Ave measure(s):

One (1) at fifteen point seven five (15.75) feet in length, and two (2) feet in width for a total of thirty-one point five (31.5) square feet.

The location of said privilege shall be as shown on prints kept on file with the Department of Business Affairs and Consumer Protection and the Office of the City Clerk.

Said privilege shall be constructed in accordance with plans and specifications approved by the Zoning Department - Signs.

This grant of privilege in the public way shall be subject to the provisions of Section 10-28-015 and all other required provisions of the Municipal Code of Chicago.

The grantee shall pay to the City of Chicago as compensation for the privilege #1102570 herein granted the sum of fifty (\$50.00) per annum in advance.

A 25% penalty will be added for payments received after due date.

The permit holder agrees to hold the City of Chicago harmless for any damage, relocation or replacement costs associated with damage, relocation or removal of private property caused by the City performing work in the public way.

Authority herein given and granted for a period of five (5) years from and after Date of Passage.

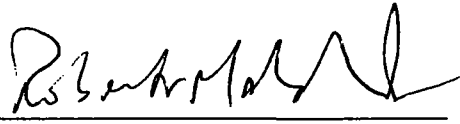
Alderman 

Roberto Maldonado 26th Ward

Side view

Left wing

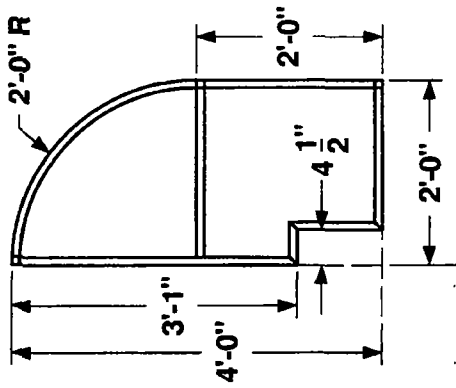

Right wing

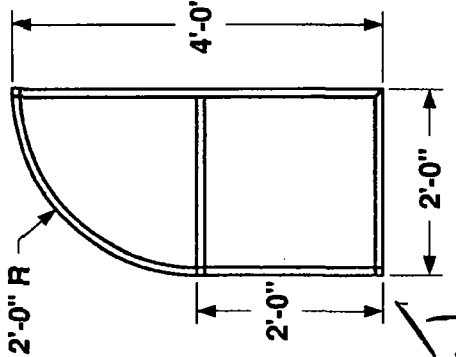

Slot

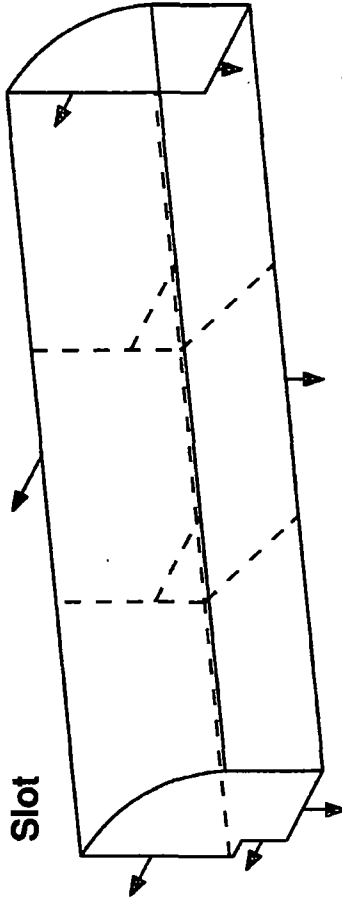

- Notes:
- alum staple frame (1)
 - tubing, slot as noted
 - silver frame finish

Job # 722064
Grandma J's

Iso view

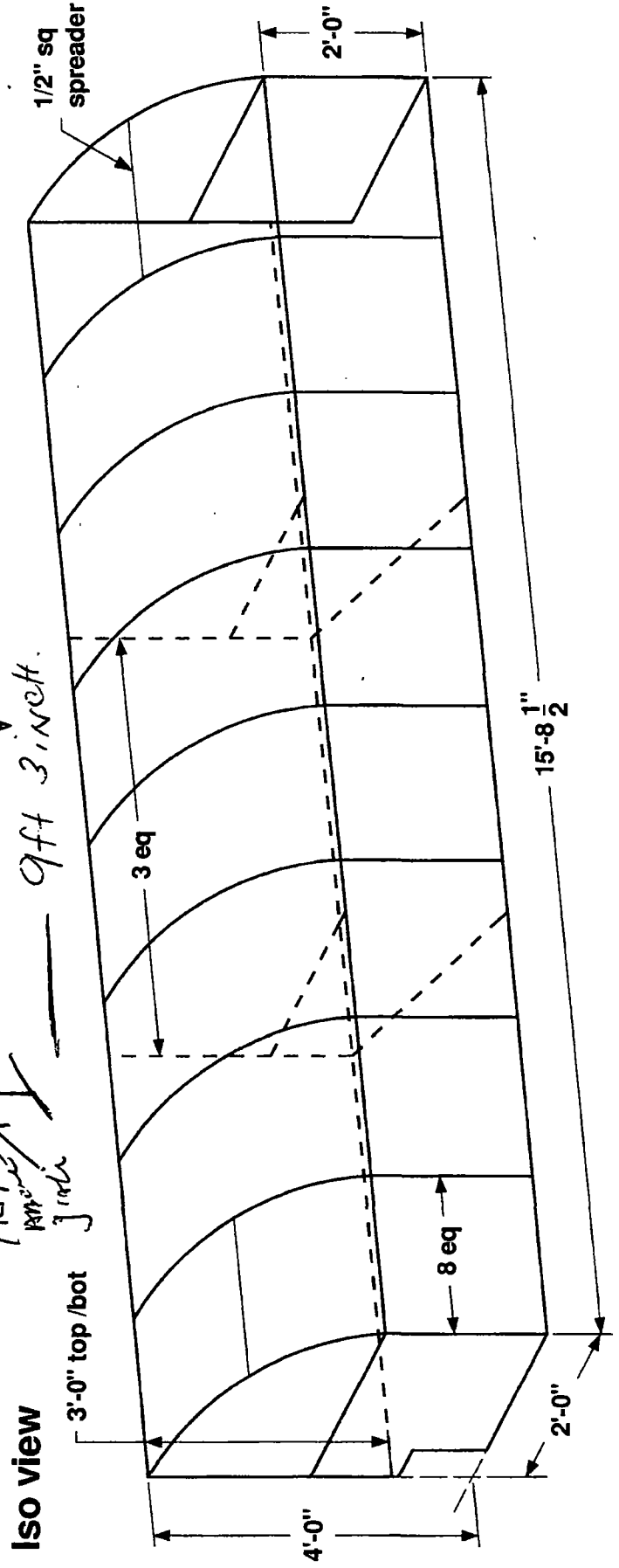



2nd ATTEMPT AT INTRODUCTION

05/28/2014

Alderman **Roberto Maldonado**
Ward # 26
City of Chicago
City Hall, Room 300
121 North LaSalle Street
Chicago, Illinois 60602

Re: An ordinance to use and maintain a portion of the public right-of-way for **one (1) awning(s)** for **Grandma J's Inc.**, adjacent to the premises known as **1552 N. Kedzie Ave.**.

Dear Alderman **Roberto Maldonado**:

The applicant referenced above has requested the use of the public right-of-way for a **awning(s)**. An ordinance has been prepared by the Department of Business Affairs and Consumer Protection – Small Business Center - Public Way Use Unit for presentation to the City Council. Because this request was made for properties located in your ward, as approved by you as per the attached, I respectfully request that you introduce the attached ordinance at the next City Council meeting.

If you have any questions regarding this ordinance, please contact Anthony Bertuca at (312) 744-5506.

Department of Business Affairs and Consumer Protection



City of Chicago



O2014-4444

Office of the City Clerk

Document Tracking Sheet

| | |
|---------------------------------|--|
| Meeting Date: | 5/28/2014 |
| Sponsor(s): | Maldonado (26) |
| Type: | Ordinance |
| Title: | Awning(s) for Rob West Plumbing, Inc. |
| Committee(s) Assignment: | Committee on Transportation and Public Way |

ORDINANCE

Rob West Plumbing, Inc
Acct. No. 364573 - 1
Permit No. 1111059

Be It Ordained by the City Council of the City of Chicago:

SECTION 1. Permission and authority are hereby given and granted to Rob West Plumbing, Inc, upon the terms and subject to the conditions of this ordinance to construct, install, maintain and use one (1) Awning(s) projecting over the public right-of-way adjacent to its premises known as 1102 N. California Ave..

Said Awning(s) at N. California Avenue measure(s):

One (1) at nineteen point six seven (19.67) feet in length, and two (2) feet in width for a total of thirty-nine point three four (39.34) square feet.

The location of said privilege shall be as shown on prints kept on file with the Department of Business Affairs and Consumer Protection and the Office of the City Clerk.

Said privilege shall be constructed in accordance with plans and specifications approved by the Zoning Department - Signs.

This grant of privilege in the public way shall be subject to the provisions of Section 10-28-015 and all other required provisions of the Municipal Code of Chicago.

The grantee shall pay to the City of Chicago as compensation for the privilege #1111059 herein granted the sum of fifty (\$50.00) per annum in advance.

A 25% penalty will be added for payments received after due date.

The permit holder agrees to hold the City of Chicago harmless for any damage, relocation or replacement costs associated with damage, relocation or removal of private property caused by the City performing work in the public way.

Authority herein given and granted for a period of five (5) years from and after Date of Passage.

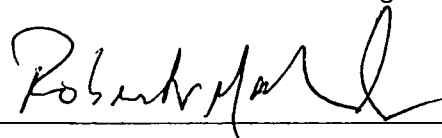
Alderman 

Roberto Maldonado 26th Ward



REVISION
3

Please carefully review and sign below if this layout meets your approval. Note that upon signing this graphics sheet you are approving this design for production. You will have approximately One (1) week from the date below to approve, before delaying production of your project.

This is an original drawing created by Chesterfield Awning Company, Inc. It is being submitted for your personal use in connection with a project being planned for you by Chesterfield Awning Company, Inc. It is not to be used, reproduced, copied or exhibited in any fashion. In the event any of the above occurs, Chesterfield Awning company, inc. expects to be reimbursed \$250.00 in compensation for the time and effort entailed in creating this drawing.

SIDE VIEW

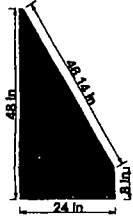

FRONT VIEW

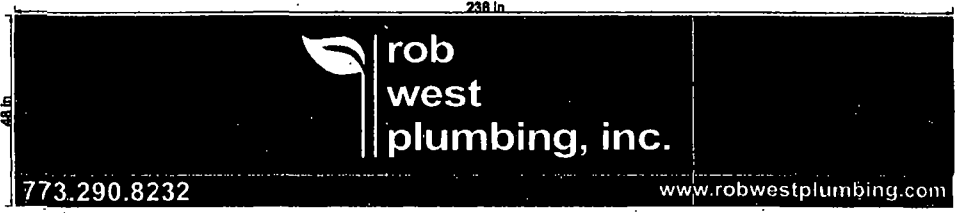

108" to bottom of frame
192" wall to curb

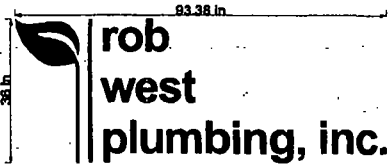
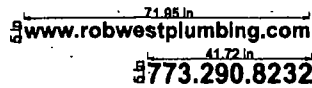

File Name: Rob West Plumbing
 Job Number: Sunbrella Ivy 4632
 Font Style: Custom Lime Green / White PX 75 Nazdar Ink
 Size/Style: Arial Bold Font / Custom Logo
 Color/Method: 01/27-2014
 Salesman: Ed Ritzema
 Date:

Please carefully check for grammatical errors, misspellings, missing actions, placement, sizing, colors and etc. Please note this does not to include representational color.

Contact: Matthew Coglianese | graphics@chesterfieldawning.com
 Sizes are approximate, changes can/will be made after field measuring prior to installation.
PLEASE CAREFULLY REVIEW THIS DRAWING, IF YOU SIGN AND APPROVE IT WITH INCORRECT INFORMATION. IT WILL BE AT YOUR EXPENSE TO CORRECT

Customer Approval _____ Date _____ Sales Approval _____ Date _____



05/28/2014

Alderman **Roberto Maldonado**
Ward # **26**
City of Chicago
City Hall, Room **300**
121 North LaSalle Street
Chicago, Illinois 60602

Re: An ordinance to use and maintain a portion of the public right-of-way for **one (1) awning(s)** for **Rob West Plumbing, Inc**, adjacent to the premises known as **1102 N. California Ave.**.

Dear Alderman **Roberto Maldonado**:

The applicant referenced above has requested the use of the public right-of-way for a **awning(s)**. An ordinance has been prepared by the Department of Business Affairs and Consumer Protection – Small Business Center - Public Way Use Unit for presentation to the City Council. Because this request was made for properties located in your ward, as approved by you as per the attached, I respectfully request that you introduce the attached ordinance at the next City Council meeting.

If you have any questions regarding this ordinance, please contact Anthony Bertuca at (312) 744-5506.

Department of Business Affairs and Consumer Protection



City of Chicago



O2014-4448

Office of the City Clerk

Document Tracking Sheet

| | |
|---------------------------------|---|
| Meeting Date: | 5/28/2014 |
| Sponsor(s): | Burnett (27) |
| Type: | Ordinance |
| Title: | Awning(s) for Chasing Tails 4 U Pet Fitness, Inc. |
| Committee(s) Assignment: | Committee on Transportation and Public Way |

ORDINANCE
CHASING TAILS 4 U PET FITNESS, INC.
Acct. No. 374328 - 1
Permit No. 1111645

Be It Ordained by the City Council of the City of Chicago:

SECTION 1. Permission and authority are hereby given and granted to CHASING TAILS 4 U PET FITNESS, INC., upon the terms and subject to the conditions of this ordinance to construct, install, maintain and use one (1) Awning(s) projecting over the public right-of-way adjacent to its premises known as 1724 W. Lake St..

Said Awning(s) at W. Lake Street measure(s):

One (1) at thirteen (13) feet in length, and two (2) feet in width for a total of twenty-six (26) square feet.

The location of said privilege shall be as shown on prints kept on file with the Department of Business Affairs and Consumer Protection and the Office of the City Clerk.

Said privilege shall be constructed in accordance with plans and specifications approved by the Zoning Department - Signs.

This grant of privilege in the public way shall be subject to the provisions of Section 10-28-015 and all other required provisions of the Municipal Code of Chicago.

The grantee shall pay to the City of Chicago as compensation for the privilege #1111645 herein granted the sum of fifty (\$50.00) per annum in advance.

A 25% penalty will be added for payments received after due date.

The permit holder agrees to hold the City of Chicago harmless for any damage, relocation or replacement costs associated with damage, relocation or removal of private property caused by the City performing work in the public way.

Authority herein given and granted for a period of five (5) years from and after Date of Passage.

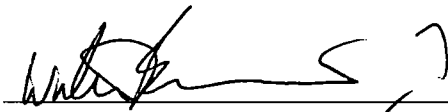
Alderman 
Walter Burnett Jr. 27th Ward

SIGN: Awning

CROSS SECTION DETAIL

Installation Detail

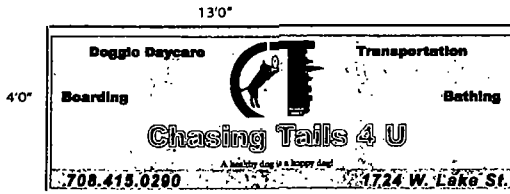
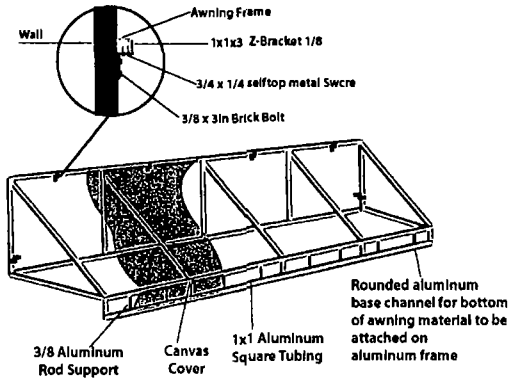

- ALUMINUM FRAMED AWNING
- PRINTED LOGO IN BLACK AND GREEN
- WALL MOUNTED
- READS: CHASING TAILS 4 U 708.415.0290 1724 W LAKE ST DOGGIE DAYCARE, BOARDING, TRANSPORTATION, BATHING

Applicant:

Chasing Tail 4U
 1724 W. LAKE ST.
 Chicago, IL 60624
 Tel: 708.415.0290

Location:

Front Elevation

Date:

02-4-2014



City of Chicago



O2014-4451

Office of the City Clerk Document Tracking Sheet

| | |
|---------------------------------|--|
| Meeting Date: | 5/28/2014 |
| Sponsor(s): | Burnett (27) |
| Type: | Ordinance |
| Title: | Awning(s) for Suite Lounge |
| Committee(s) Assignment: | Committee on Transportation and Public Way |

ORDINANCE
SUITE LOUNGE
Acct. No. 11459 - 1
Permit No. 1113158

Be It Ordained by the City Council of the City of Chicago:

SECTION 1. Permission and authority are hereby given and granted to SUITE LOUNGE, upon the terms and subject to the conditions of this ordinance to maintain and use, as now constructed, one (1) Awning(s) projecting over the public right-of-way adjacent to its premises known as 1446 N. Wells St..

Said Awning(s) at N. Wells Street measure(s):

One (1) at nine (9) feet in length, and six (6) feet in width for a total of fifty-four (54) square feet.

The location of said privilege shall be as shown on prints kept on file with the Department of Business Affairs and Consumer Protection and the Office of the City Clerk.

Said privilege shall be constructed in accordance with plans and specifications approved by the Zoning Department - Signs.

This grant of privilege in the public way shall be subject to the provisions of Section 10-28-015 and all other required provisions of the Municipal Code of Chicago.

The grantee shall pay to the City of Chicago as compensation for the privilege #1113158 herein granted the sum of fifty (\$50.00) per annum in advance.

A 25% penalty will be added for payments received after due date.

The permit holder agrees to hold the City of Chicago harmless for any damage, relocation or replacement costs associated with damage, relocation or removal of private property caused by the City performing work in the public way.

Authority herein given and granted for a period of five (5) years from and after 06/28/2014.

Alderman 
Walter Burnett Jr. 27th Ward

N. Wells Street

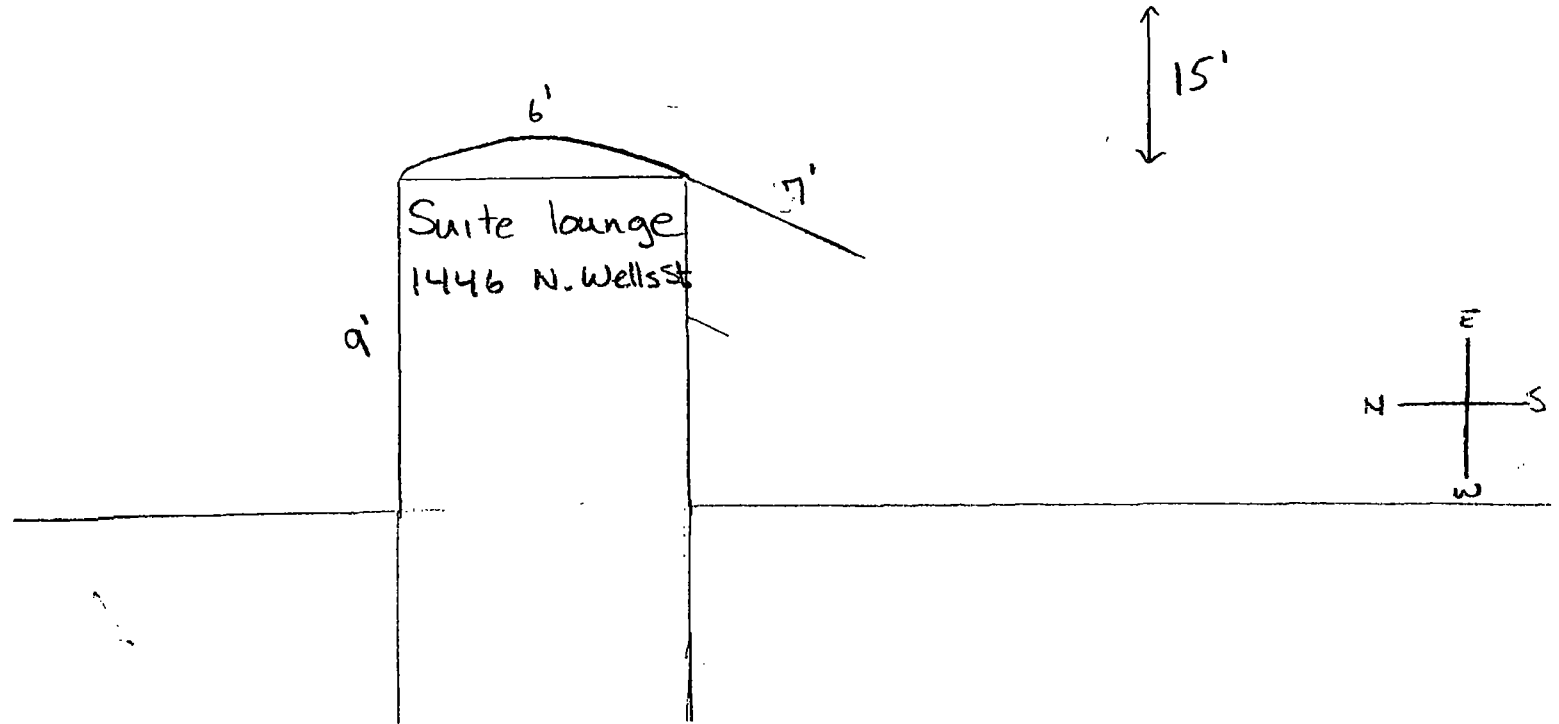



City of Chicago



O2014-4458

Office of the City Clerk

Document Tracking Sheet

| | |
|---------------------------------|--|
| Meeting Date: | 5/28/2014 |
| Sponsor(s): | Reboyras (30) |
| Type: | Ordinance |
| Title: | Awning(s) for Armitage Hair Salon |
| Committee(s) Assignment: | Committee on Transportation and Public Way |

ORDINANCE
ARMITAGE HAIR SALON
Acct. No. 63425 - 1
Permit No. 1112878

Be It Ordained by the City Council of the City of Chicago:

SECTION 1. Permission and authority are hereby given and granted to ARMITAGE HAIR SALON, upon the terms and subject to the conditions of this ordinance to maintain and use, as now constructed, one (1) Awning(s) projecting over the public right-of-way adjacent to its premises known as 4257 W. Armitage Ave..

Said Awning(s) at W Armitage Ave measure(s):

One (1) at thirty-six point five eight (36.58) feet in length, and two (2) feet in width for a total of seventy-three point one six (73.16) square feet.

The location of said privilege shall be as shown on prints kept on file with the Department of Business Affairs and Consumer Protection and the Office of the City Clerk.

Said privilege shall be constructed in accordance with plans and specifications approved by the Zoning Department - Signs.

This grant of privilege in the public way shall be subject to the provisions of Section 10-28-015 and all other required provisions of the Municipal Code of Chicago.

The grantee shall pay to the City of Chicago as compensation for the privilege #1112878 herein granted the sum of sixty-one dollars and fifty-eight cents (\$61.58) per annum in advance.

A 25% penalty will be added for payments received after due date.

The permit holder agrees to hold the City of Chicago harmless for any damage, relocation or replacement costs associated with damage, relocation or removal of private property caused by the City performing work in the public way.

Authority herein given and granted for a period of five (5) years from and after 03/18/2014.

Alderman _____

Ariel Reboyras 30th Ward

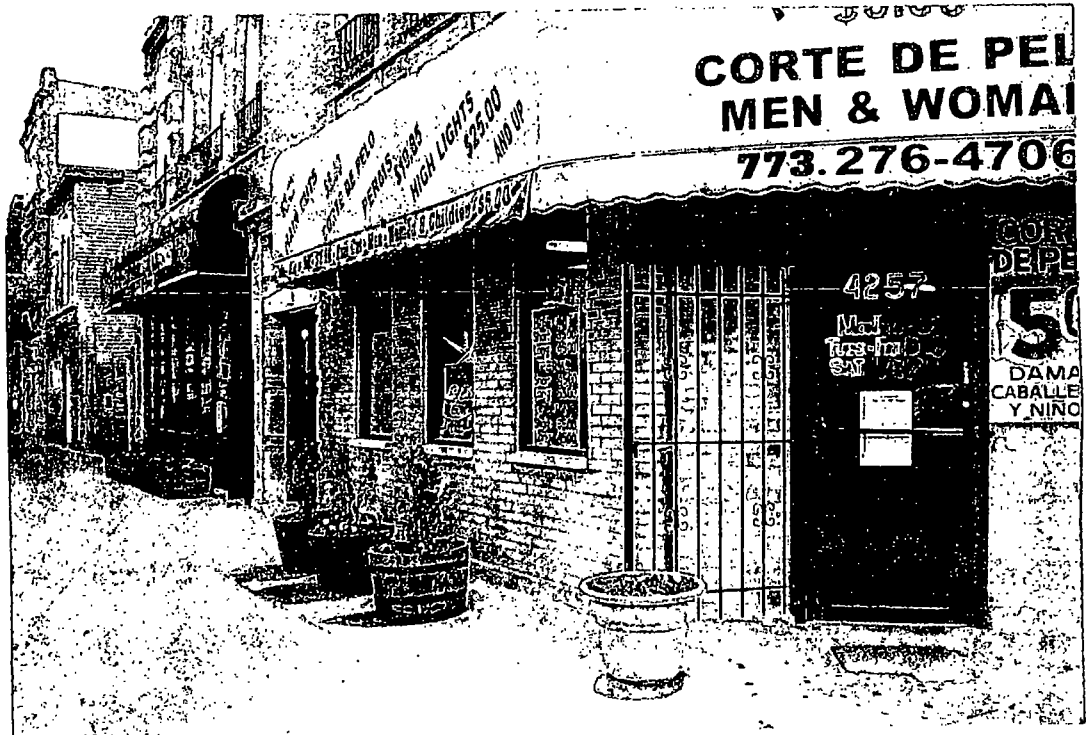



05/28/2014

Alderman **Ariel Reboyras**
Ward # **30**
City of Chicago
City Hall, Room **203**
121 North LaSalle Street
Chicago, Illinois 60602

Re: An ordinance to use and maintain a portion of the public right-of-way for **one (1) awning(s)** for **ARMITAGE HAIR SALON**, adjacent to the premises known as **4257 W. Armitage Ave.**.

Dear Alderman **Ariel Reboyras**:

The applicant referenced above has requested the use of the public right-of-way for a **awning(s)**. An ordinance has been prepared by the Department of Business Affairs and Consumer Protection – Small Business Center - Public Way Use Unit for presentation to the City Council. Because this request was made for properties located in your ward, as approved by you as per the attached, I respectfully request that you introduce the attached ordinance at the next City Council meeting.

If you have any questions regarding this ordinance, please contact Anthony Bertuca at (312) 744-5506.

Department of Business Affairs and Consumer Protection



City of Chicago



O2014-4462

Office of the City Clerk Document Tracking Sheet

| | |
|---------------------------------|--|
| Meeting Date: | 5/28/2014 |
| Sponsor(s): | Suarez (31) |
| Type: | Ordinance |
| Title: | Awning(s) for Barbara Deerfler |
| Committee(s) Assignment: | Committee on Transportation and Public Way |

ORDINANCE
BARBARA DEERFLER
Acct. No. 340245 - 1
Permit No. 1112997

Be It Ordained by the City Council of the City of Chicago:

SECTION 1. Permission and authority are hereby given and granted to BARBARA DEERFLER, upon the terms and subject to the conditions of this ordinance to maintain and use, as now constructed, one (1) Awning(s) projecting over the public right-of-way adjacent to its premises known as 5143 W. Diversey Ave..

Said Awning(s) at W DIVERSEY AVE measure(s):

One (1) at twenty-five (25) feet in length, and five (5) feet in width for a total of one hundred twenty-five (125) square feet.

The location of said privilege shall be as shown on prints kept on file with the Department of Business Affairs and Consumer Protection and the Office of the City Clerk.

Said privilege shall be constructed in accordance with plans and specifications approved by the Zoning Department - Signs.

This grant of privilege in the public way shall be subject to the provisions of Section 10-28-015 and all other required provisions of the Municipal Code of Chicago.

The grantee shall pay to the City of Chicago as compensation for the privilege #1112997 herein granted the sum of fifty (\$50.00) per annum in advance.

A 25% penalty will be added for payments received after due date.

The permit holder agrees to hold the City of Chicago harmless for any damage, relocation or replacement costs associated with damage, relocation or removal of private property caused by the City performing work in the public way.

Authority herein given and granted for a period of five (5) years from and after 03/18/2014.

Alderman

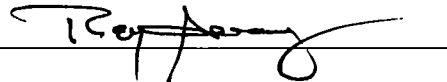

Ray Suarez 31st Ward

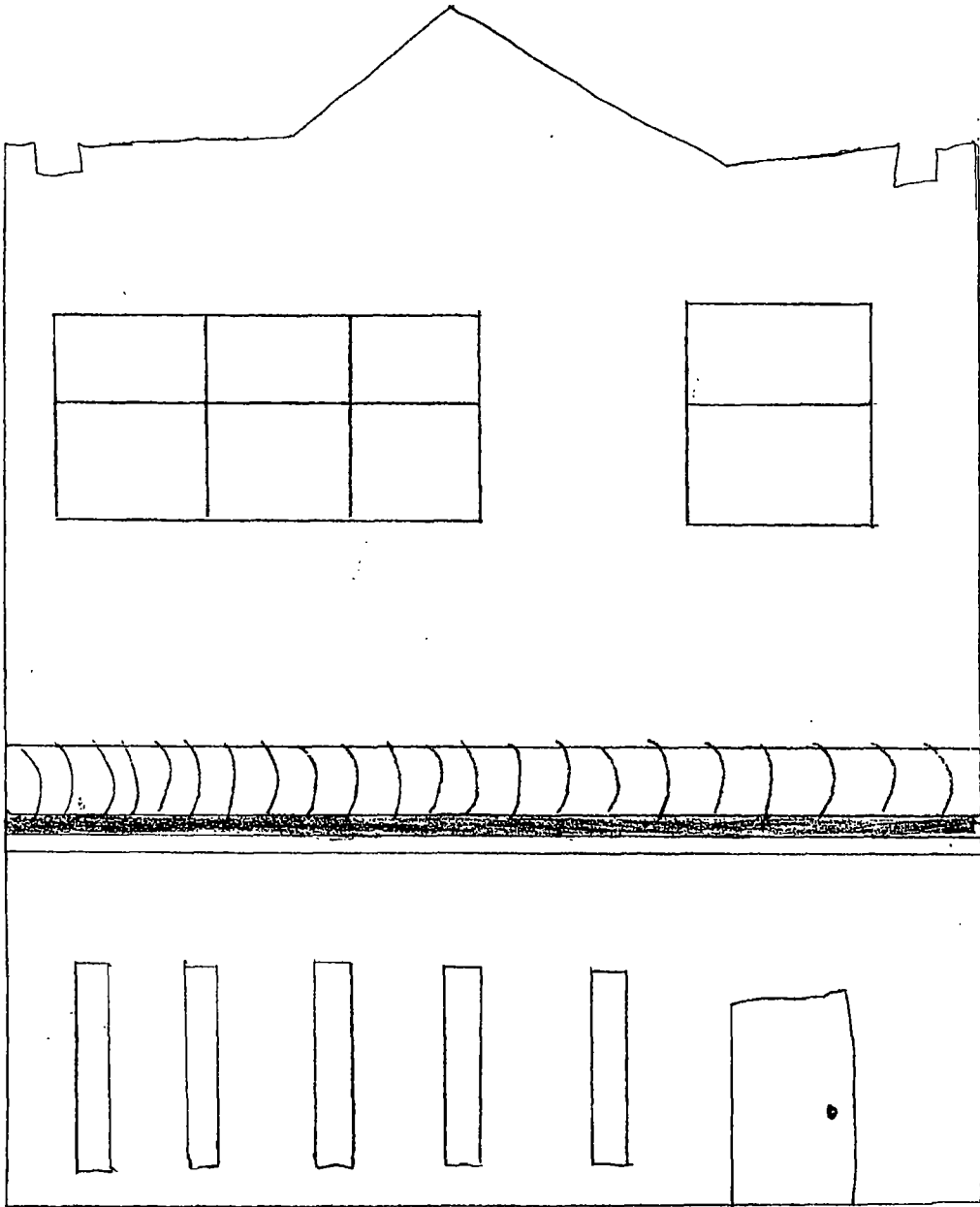

LOT 3,100 sq. ft
Bldg. 2,616 sq. ft





05/28/2014

Alderman **Ray Suarez**
Ward # **31**
City of Chicago
City Hall, Room **203**
121 North LaSalle Street
Chicago, Illinois 60602

Re: An ordinance to use and maintain a portion of the public right-of-way for **one (1) awning(s)** for **BARBARA DEERFLER**, adjacent to the premises known as **5143 W. Diversey Ave.**.

Dear Alderman **Ray Suarez**:

The applicant referenced above has requested the use of the public right-of-way for a **awning(s)**. An ordinance has been prepared by the Department of Business Affairs and Consumer Protection – Small Business Center - Public Way Use Unit for presentation to the City Council. Because this request was made for properties located in your ward, as approved by you as per the attached, I respectfully request that you introduce the attached ordinance at the next City Council meeting.

If you have any questions regarding this ordinance, please contact Anthony Bertuca at (312) 744-5506.

Department of Business Affairs and Consumer Protection



City of Chicago



O2014-4473

Office of the City Clerk

Document Tracking Sheet

| | |
|---------------------------------|--|
| Meeting Date: | 5/28/2014 |
| Sponsor(s): | Suarez (31) |
| Type: | Ordinance |
| Title: | Awning(s) for V & J America Multiservices |
| Committee(s) Assignment: | Committee on Transportation and Public Way |

ORDINANCE
V & J AMERICA MULTISERVICES
Acct. No. 339740 - 1
Permit No. 1113097

Be It Ordained by the City Council of the City of Chicago:

SECTION 1. Permission and authority are hereby given and granted to V & J AMERICA MULTISERVICES, upon the terms and subject to the conditions of this ordinance to maintain and use, as now constructed, one (1) Awning(s) projecting over the public right-of-way adjacent to its premises known as 4420 W. Armitage Ave..

Said Awning(s) at W. ARMITAGE measure(s):

One (1) at eighteen (18) feet in length, and two point five (2.5) feet in width for a total of forty-five (45) square feet.

The location of said privilege shall be as shown on prints kept on file with the Department of Business Affairs and Consumer Protection and the Office of the City Clerk.

Said privilege shall be constructed in accordance with plans and specifications approved by the Zoning Department - Signs.

This grant of privilege in the public way shall be subject to the provisions of Section 10-28-015 and all other required provisions of the Municipal Code of Chicago.

The grantee shall pay to the City of Chicago as compensation for the privilege #1113097 herein granted the sum of fifty (\$50.00) per annum in advance.

A 25% penalty will be added for payments received after due date.

The permit holder agrees to hold the City of Chicago harmless for any damage, relocation or replacement costs associated with damage, relocation or removal of private property caused by the City performing work in the public way.

Authority herein given and granted for a period of five (5) years from and after 04/22/2014.

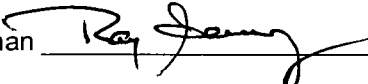
Alderman 
Ray Suarez 31st Ward

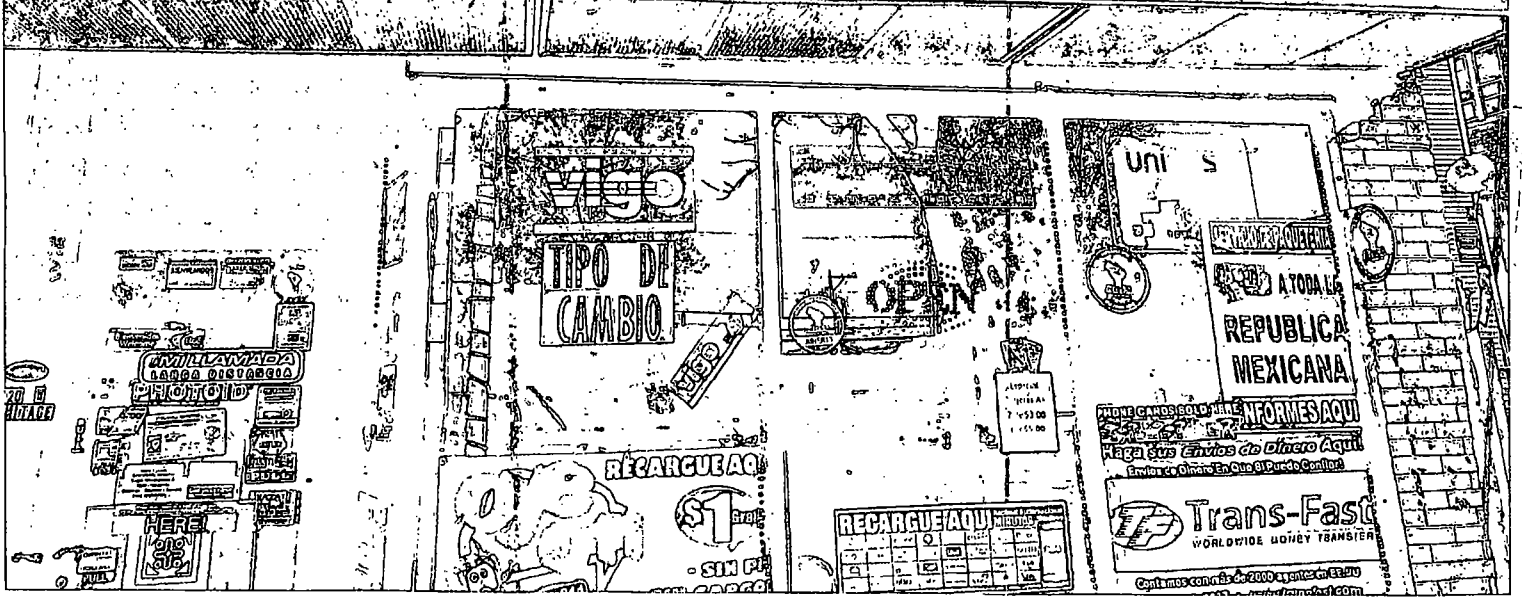
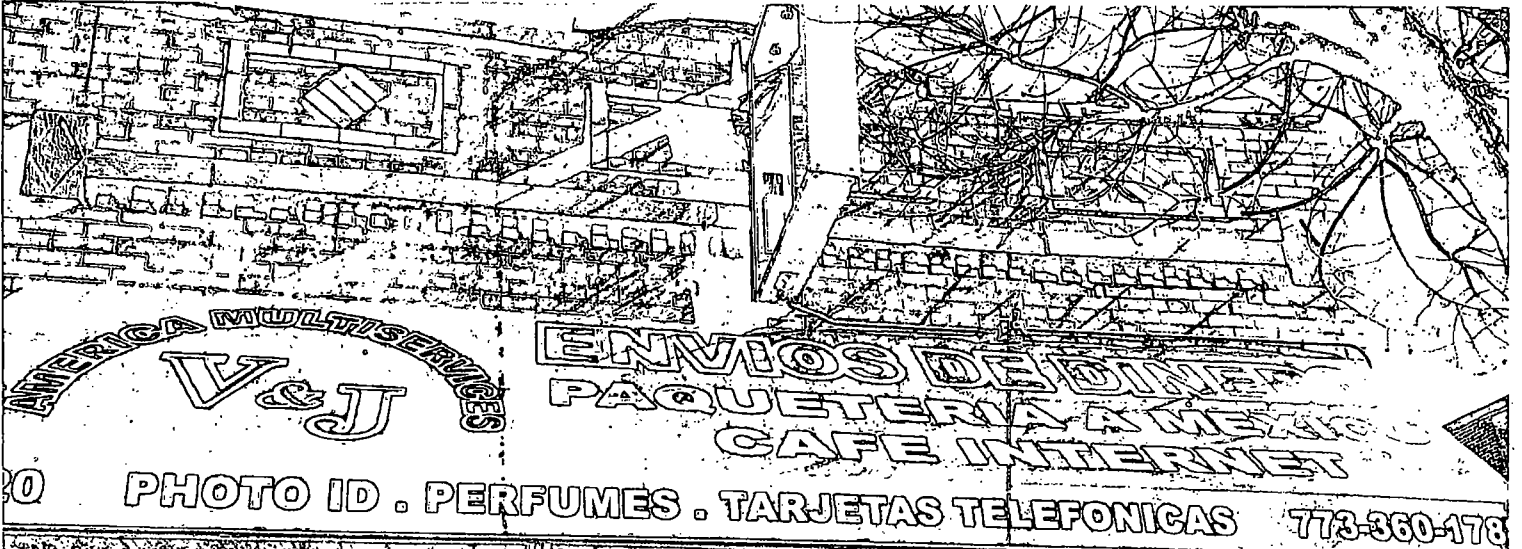



05/28/2014

Alderman **Ray Suarez**
Ward # **31**
City of Chicago
City Hall, Room **203**
121 North LaSalle Street
Chicago, Illinois 60602

Re: An ordinance to use and maintain a portion of the public right-of-way for **one (1) awning(s)** for **V & J AMERICA MULTISERVICES**, adjacent to the premises known as **4420 W. Armitage Ave.**.

Dear Alderman **Ray Suarez**:

The applicant referenced above has requested the use of the public right-of-way for a **awning(s)**. An ordinance has been prepared by the Department of Business Affairs and Consumer Protection – Small Business Center - Public Way Use Unit for presentation to the City Council. Because this request was made for properties located in your ward, as approved by you as per the attached, I respectfully request that you introduce the attached ordinance at the next City Council meeting.

If you have any questions regarding this ordinance, please contact Anthony Bertuca at (312) 744-5506.

Department of Business Affairs and Consumer Protection



City of Chicago



O2014-4479

Office of the City Clerk

Document Tracking Sheet

| | |
|---------------------------------|--|
| Meeting Date: | 5/28/2014 |
| Sponsor(s): | Waguespack (32) |
| Type: | Ordinance |
| Title: | Awning(s) for BFF Bikes |
| Committee(s) Assignment: | Committee on Transportation and Public Way |

ORDINANCE
BFF Bikes
Acct. No. 387359 - 1
Permit No. 1112041

Be It Ordained by the City Council of the City of Chicago:

SECTION 1. Permission and authority are hereby given and granted to BFF Bikes, upon the terms and subject to the conditions of this ordinance to construct, install, maintain and use one (1) Awning(s) projecting over the public right-of-way adjacent to its premises known as 2113 W. Armitage Ave..

Said Awning(s) at measure(s):

One (1) at ten (10) feet in length, and three (3) feet in width for a total of thirty (30) square feet.

The location of said privilege shall be as shown on prints kept on file with the Department of Business Affairs and Consumer Protection and the Office of the City Clerk.

Said privilege shall be constructed in accordance with plans and specifications approved by the Zoning Department - Signs.

This grant of privilege in the public way shall be subject to the provisions of Section 10-28-015 and all other required provisions of the Municipal Code of Chicago.

The grantee shall pay to the City of Chicago as compensation for the privilege #1112041 herein granted the sum of fifty (\$50.00) per annum in advance.

A 25% penalty will be added for payments received after due date.

The permit holder agrees to hold the City of Chicago harmless for any damage, relocation or replacement costs associated with damage, relocation or removal of private property caused by the City performing work in the public way.

Authority herein given and granted for a period of five (5) years from and after Date of Passage.

Alderman 
Scott Waguespack 32nd Ward

PROPERTY LOCATION: 2113 W. ARMITAGE AVE, 60647

BFF BIKES, LLC

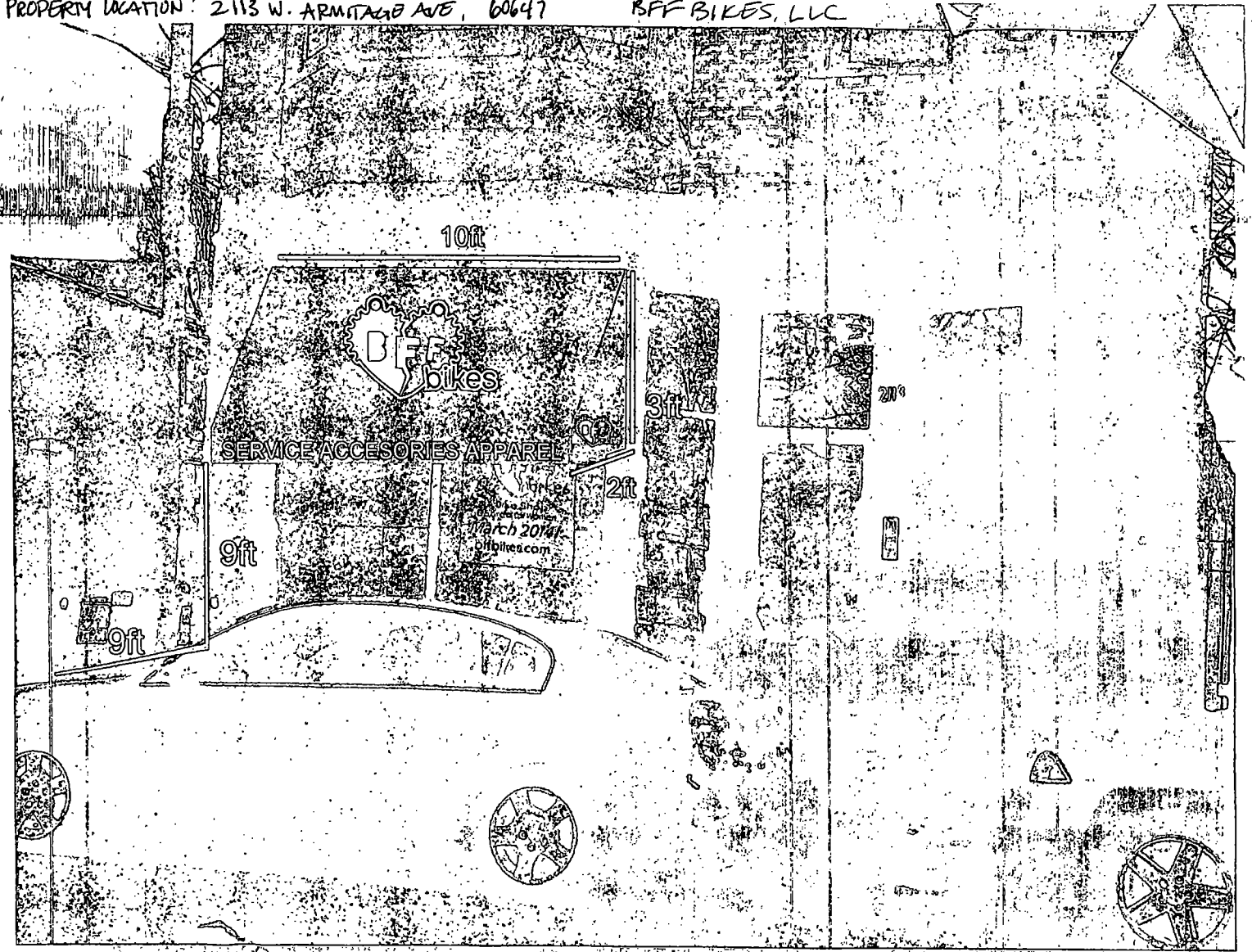



05/28/2014

Alderman **Scott Waguespack**
Ward # **32**
City of Chicago
City Hall, Room **300**
121 North LaSalle Street
Chicago, Illinois 60602

Re: An ordinance to use and maintain a portion of the public right-of-way for **one (1) awning(s)** for **BFF Bikes**, adjacent to the premises known as **2113 W. Armitage Ave.**.

Dear Alderman **Scott Waguespack**:

The applicant referenced above has requested the use of the public right-of-way for a **awning(s)**. An ordinance has been prepared by the Department of Business Affairs and Consumer Protection – Small Business Center - Public Way Use Unit for presentation to the City Council. Because this request was made for properties located in your ward, as approved by you as per the attached, I respectfully request that you introduce the attached ordinance at the next City Council meeting.

If you have any questions regarding this ordinance, please contact Anthony Bertuca at (312) 744-5506.

Department of Business Affairs and Consumer Protection



City of Chicago



O2014-4482

Office of the City Clerk Document Tracking Sheet

| | |
|---------------------------------|--|
| Meeting Date: | 5/28/2014 |
| Sponsor(s): | Waguespack (32) |
| Type: | Ordinance |
| Title: | Awning(s) for New Divine Nails and Spa |
| Committee(s) Assignment: | Committee on Transportation and Public Way |

ORDINANCE
NEW DIVINE NAILS AND SPA
Acct. No. 377327 - 1
Permit No. 1112596

Be It Ordained by the City Council of the City of Chicago:

SECTION 1. Permission and authority are hereby given and granted to NEW DIVINE NAILS AND SPA, upon the terms and subject to the conditions of this ordinance to maintain and use, as now constructed, one (1) Awning(s) projecting over the public right-of-way adjacent to its premises known as 1702 W. Belmont Ave..

Said Awning(s) at W. Belmont Avenue measure(s):

One (1) at three (3) feet in length, and one (1) foot in width for a total of three (3) square feet.

The location of said privilege shall be as shown on prints kept on file with the Department of Business Affairs and Consumer Protection and the Office of the City Clerk.

Said privilege shall be constructed in accordance with plans and specifications approved by the Zoning Department - Signs.

This grant of privilege in the public way shall be subject to the provisions of Section 10-28-015 and all other required provisions of the Municipal Code of Chicago.

The grantee shall pay to the City of Chicago as compensation for the privilege #1112596 herein granted the sum of fifty (\$50.00) per annum in advance.

A 25% penalty will be added for payments received after due date.

The permit holder agrees to hold the City of Chicago harmless for any damage, relocation or replacement costs associated with damage, relocation or removal of private property caused by the City performing work in the public way.

Authority herein given and granted for a period of five (5) years from and after Date of Passage.

Alderman 
Scott Waguespack 32nd Ward

Handwritten signature or scribble.

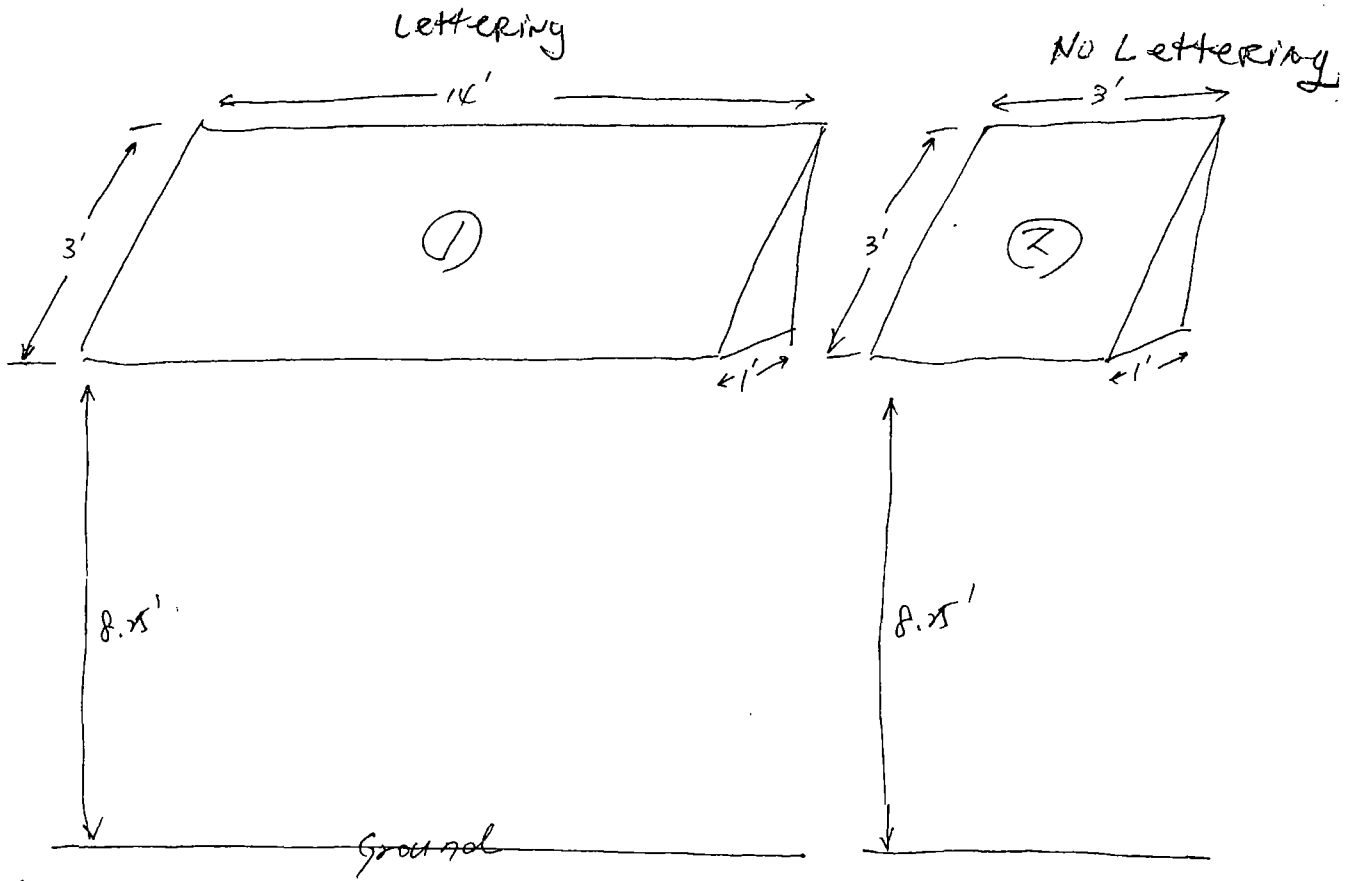



Department of Business Affairs and Consumer Protection
Small Business Center - Public Way Use Unit
City Hall - 121 N. LaSalle Street, Room 800 • Chicago, IL 60602
(312)-74-GOBIZ (312-744-6249) • (312) 744-1944 (TTY)
<http://www.cityofchicago.org/bacp>

05/28/2014

Alderman **Scott Waguespack**
Ward # 32
City of Chicago
City Hall, Room 300
121 North LaSalle Street
Chicago, Illinois 60602

Re: An ordinance to use and maintain a portion of the public right-of-way for **one (1) awning(s)** for **NEW DIVINE NAILS AND SPA**, adjacent to the premises known as **1702 W. Belmont Ave.**.

Dear Alderman **Scott Waguespack**:

The applicant referenced above has requested the use of the public right-of-way for a **awning(s)**. An ordinance has been prepared by the Department of Business Affairs and Consumer Protection – Small Business Center - Public Way Use Unit for presentation to the City Council. Because this request was made for properties located in your ward, as approved by you as per the attached, I respectfully request that you introduce the attached ordinance at the next City Council meeting.

If you have any questions regarding this ordinance, please contact Anthony Bertuca at (312) 744-5506.

Department of Business Affairs and Consumer Protection



City of Chicago



O2014-4491

Office of the City Clerk Document Tracking Sheet

| | |
|---------------------------------|--|
| Meeting Date: | 5/28/2014 |
| Sponsor(s): | Waguespack (32) |
| Type: | Ordinance |
| Title: | Awning(s) for Peek, Aren't You Curious, Inc. |
| Committee(s) Assignment: | Committee on Transportation and Public Way |

ORDINANCE
PEEK, AREN'T YOU CURIOUS, INC
Acct. No. 389797 - 1
Permit No. 1112663

Be It Ordained by the City Council of the City of Chicago:

SECTION 1. Permission and authority are hereby given and granted to PEEK, AREN'T YOU CURIOUS, INC, upon the terms and subject to the conditions of this ordinance to construct, install, maintain and use one (1) Awning(s) projecting over the public right-of-way adjacent to its premises known as 1723 N. Damen Ave..

Said Awning(s) at Damen measure(s):

One (1) at twenty point five eight (20.58) feet in length, and three point three three (3.33) feet in width for a total of sixty-eight point five three (68.53) square feet.

The location of said privilege shall be as shown on prints kept on file with the Department of Business Affairs and Consumer Protection and the Office of the City Clerk.

Said privilege shall be constructed in accordance with plans and specifications approved by the Zoning Department - Signs.

This grant of privilege in the public way shall be subject to the provisions of Section 10-28-015 and all other required provisions of the Municipal Code of Chicago.

The grantee shall pay to the City of Chicago as compensation for the privilege #1112663 herein granted the sum of fifty (\$50.00) per annum in advance.

A 25% penalty will be added for payments received after due date.

The permit holder agrees to hold the City of Chicago harmless for any damage, relocation or replacement costs associated with damage, relocation or removal of private property caused by the City performing work in the public way.

Authority herein given and granted for a period of five (5) years from and after Date of Passage.

Alderman 
Scott Waguespack 32nd Ward

Handwritten signature or scribble.

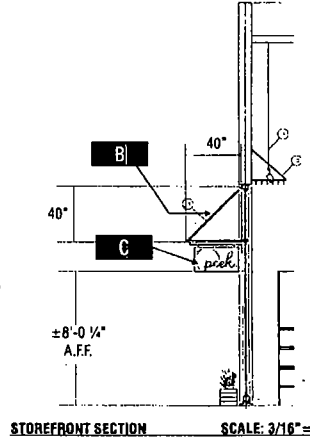
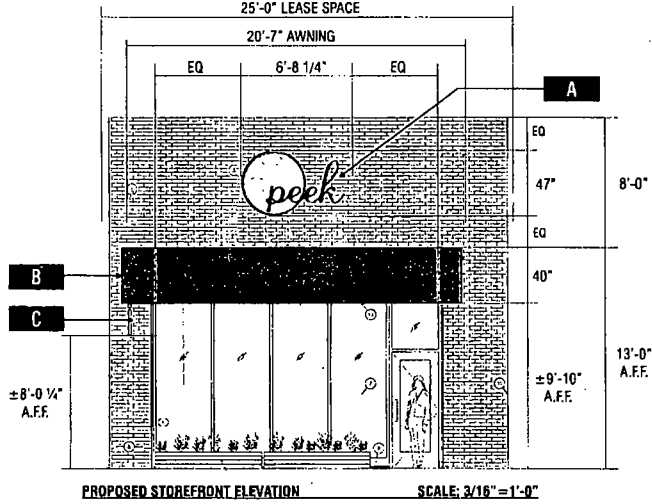
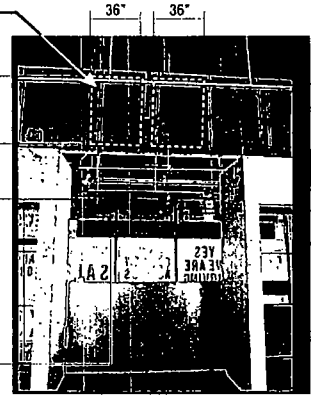
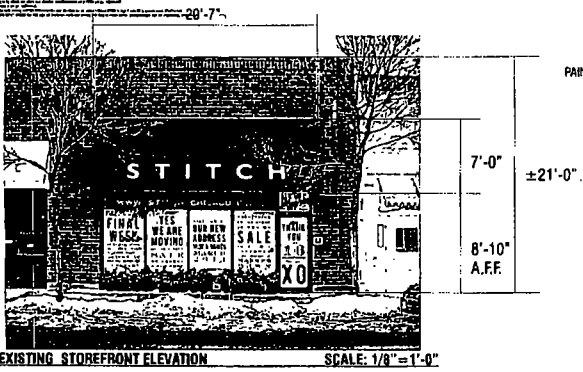

Signtech

4444 Federal Blvd. San Diego CA 92182
 Phone (619) 527-4109 / Fax: (619) 527-4111
 www.signtechUSA.com



Peek...Aren't You Curious

1723 North Damen Ave
 Chicago, IL 60647

Initial Date: 03/19/14
 Salesperson: Matthew Thompson
 Coordinator: Gladys Ojeda
 Designer: Svetlana Mladynova
 Scale: As noted

CUSTOMER APPROVAL

Customer Signature _____ Date _____
COPY COLORS & SIZES

Signtech does NOT provide primary electrical to sign location - **RESPONSIBILITY OF OTHERS!**

Customer Signature _____ Date _____

This design is the exclusive property of Signtech and cannot be reproduced in whole or in part, without their prior written approval.

Drawing Number: 14-00410
 Work Order Number: 62198



05/28/2014

Alderman **Scott Waguespack**
Ward # **32**
City of Chicago
City Hall, Room **300**
121 North LaSalle Street
Chicago, Illinois 60602

Re: An ordinance to use and maintain a portion of the public right-of-way for **one (1) awning(s)** for
PEEK, AREN'T YOU CURIOUS, INC, adjacent to the premises known as **1723 N. Damen Ave.**.

Dear Alderman **Scott Waguespack**:

The applicant referenced above has requested the use of the public right-of-way for a **awning(s)**. An ordinance has been prepared by the Department of Business Affairs and Consumer Protection – Small Business Center - Public Way Use Unit for presentation to the City Council. Because this request was made for properties located in your ward, as approved by you as per the attached, I respectfully request that you introduce the attached ordinance at the next City Council meeting.

If you have any questions regarding this ordinance, please contact Anthony Bertuca at (312) 744-5506.

Department of Business Affairs and Consumer Protection



City of Chicago



O2014-4498

Office of the City Clerk

Document Tracking Sheet

| | |
|---------------------------------|--|
| Meeting Date: | 5/28/2014 |
| Sponsor(s): | Waguespack (32) |
| Type: | Ordinance |
| Title: | Awning(s) for 24 Karrots |
| Committee(s) Assignment: | Committee on Transportation and Public Way |

ORDINANCE
24 KARROTS
Acct. No. 386385 - 1
Permit No. 1111410

Be It Ordained by the City Council of the City of Chicago:

SECTION 1. Permission and authority are hereby given and granted to 24 KARROTS, upon the terms and subject to the conditions of this ordinance to construct, install, maintain and use one (1) Awning(s) projecting over the public right-of-way adjacent to its premises known as 2004 W. Armitage Ave..

Said Awning(s) at W Armitage Ave measure(s):

One (1) at nineteen (19) feet in length, and two (2) feet in width for a total of thirty-eight (38) square feet.

The location of said privilege shall be as shown on prints kept on file with the Department of Business Affairs and Consumer Protection and the Office of the City Clerk.

Said privilege shall be constructed in accordance with plans and specifications approved by the Zoning Department - Signs.

This grant of privilege in the public way shall be subject to the provisions of Section 10-28-015 and all other required provisions of the Municipal Code of Chicago.

The grantee shall pay to the City of Chicago as compensation for the privilege #1111410 herein granted the sum of fifty (\$50.00) per annum in advance.

A 25% penalty will be added for payments received after due date.

The permit holder agrees to hold the City of Chicago harmless for any damage, relocation or replacement costs associated with damage, relocation or removal of private property caused by the City performing work in the public way.

Authority herein given and granted for a period of five (5) years from and after Date of Passage.

Alderman 
Scott Waguespack 32nd Ward

Awning /Fabric

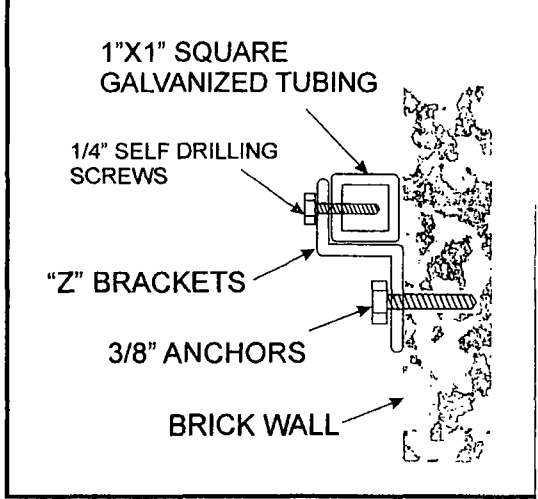
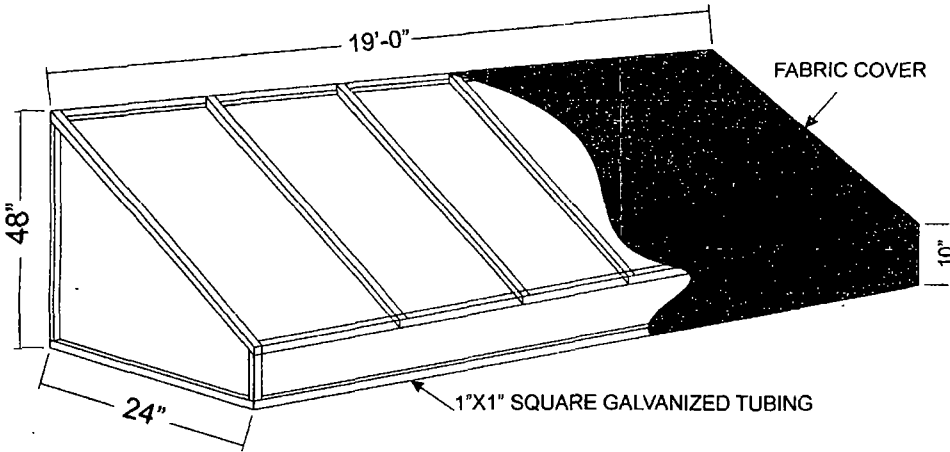

Client: 24 Karrots
 Address: 2004 W. Armitage
 Chicago, IL
 Tel: _____
 Email: _____

Landlord: _____
 Address: _____
 Tel: _____
 Email: _____

Start Date: 3/31/14
 Last Revision: 3/31/14
 Job#: 033114_2
 Drawing#: 24karrot
 Page: 2 of 2

.....
 Client Approval

 Landlord Approval

Sales Rep:
 Sean Park
 Designer:
 E322358



05/28/2014

Alderman **Scott Waguespack**
Ward # **32**
City of Chicago
City Hall, Room **300**
121 North LaSalle Street
Chicago, Illinois 60602

Re: An ordinance to use and maintain a portion of the public right-of-way for **one (1) awning(s)** for **24 KARROTS**, adjacent to the premises known as **2004 W. Armitage Ave.**.

Dear Alderman **Scott Waguespack**:

The applicant referenced above has requested the use of the public right-of-way for a **awning(s)**. An ordinance has been prepared by the Department of Business Affairs and Consumer Protection – Small Business Center - Public Way Use Unit for presentation to the City Council. Because this request was made for properties located in your ward, as approved by you as per the attached, I respectfully request that you introduce the attached ordinance at the next City Council meeting.

If you have any questions regarding this ordinance, please contact Anthony Bertuca at (312) 744-5506.

Department of Business Affairs and Consumer Protection



City of Chicago



O2014-4512

Office of the City Clerk

Document Tracking Sheet

| | |
|---------------------------------|--|
| Meeting Date: | 5/28/2014 |
| Sponsor(s): | Colón (35) |
| Type: | Ordinance |
| Title: | Awning(s) for Beauty Box Hair Salon & Spa |
| Committee(s) Assignment: | Committee on Transportation and Public Way |

ORDINANCE
BEAUTY BOX HAIR SALON & SPA
Acct. No. 61767 - 3
Permit No. 1112948

Be It Ordained by the City Council of the City of Chicago:

SECTION 1. Permission and authority are hereby given and granted to BEAUTY BOX HAIR SALON & SPA, upon the terms and subject to the conditions of this ordinance to maintain and use, as now constructed, one (1) Awning(s) projecting over the public right-of-way adjacent to its premises known as 2944 W. Diversey Ave..

Said Awning(s) at W. Diversey measure(s):
One (1) at twelve (12) feet in length, and one (1) foot in width for a total of twelve (12) square feet.

The location of said privilege shall be as shown on prints kept on file with the Department of Business Affairs and Consumer Protection and the Office of the City Clerk.

Said privilege shall be constructed in accordance with plans and specifications approved by the Zoning Department - Signs.

This grant of privilege in the public way shall be subject to the provisions of Section 10-28-015 and all other required provisions of the Municipal Code of Chicago.

The grantee shall pay to the City of Chicago as compensation for the privilege #1112948 herein granted the sum of fifty (\$50.00) per annum in advance.

A 25% penalty will be added for payments received after due date.

The permit holder agrees to hold the City of Chicago harmless for any damage, relocation or replacement costs associated with damage, relocation or removal of private property caused by the City performing work in the public way.

Authority herein given and granted for a period of five (5) years from and after 03/18/2014.

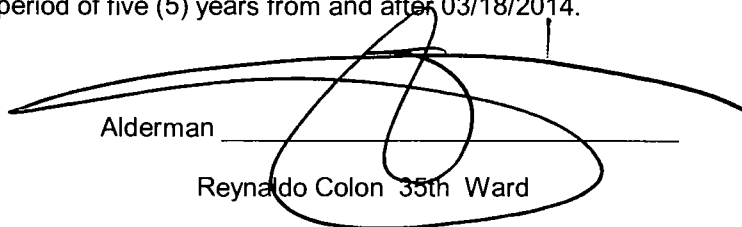
Alderman _____
Reynaldo Colon 35th Ward

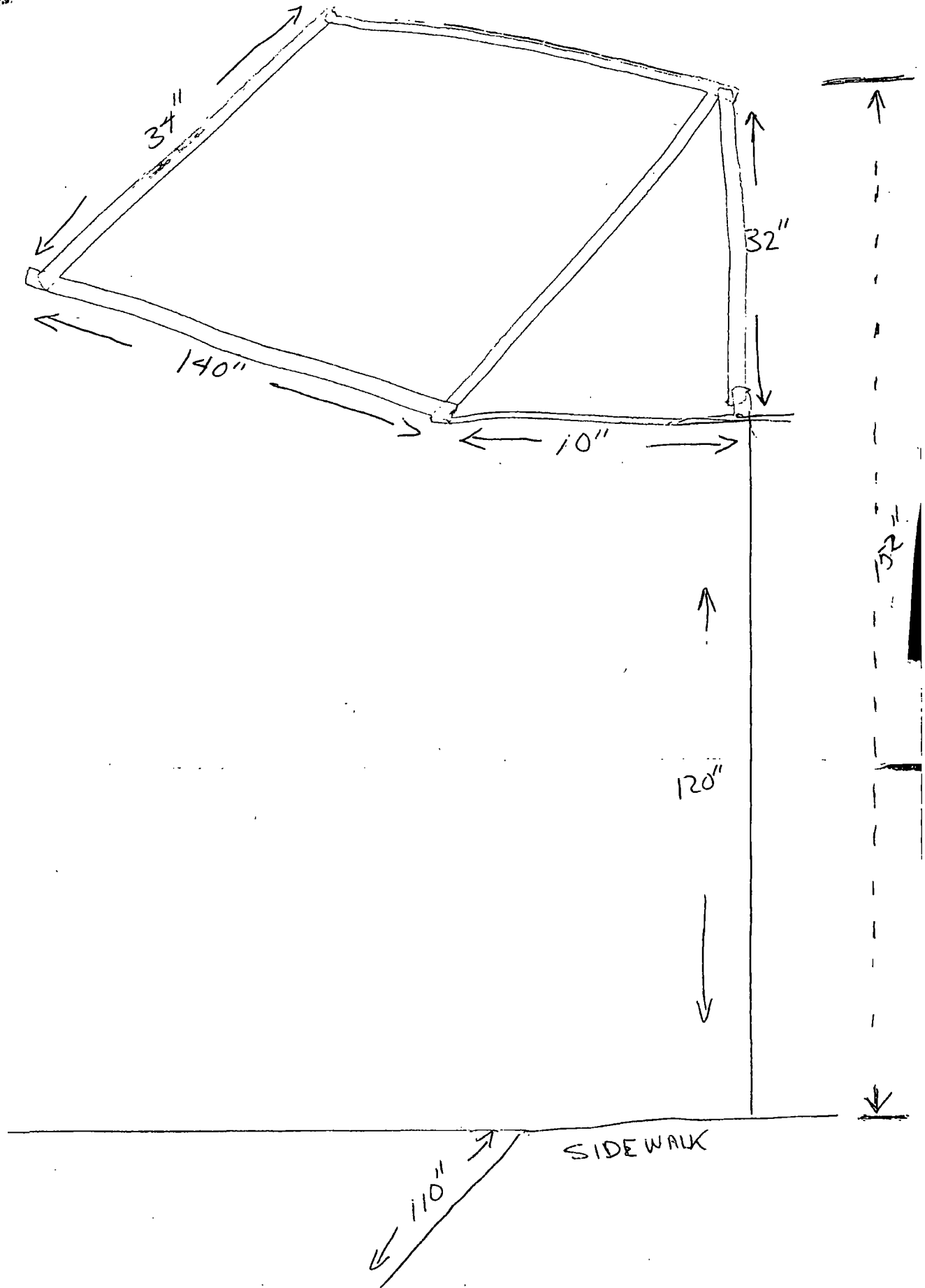



05/28/2014

Alderman **Reynaldo Colon**
Ward # **35**
City of Chicago
City Hall, Room **203**
121 North LaSalle Street
Chicago, Illinois 60602

Re: An ordinance to use and maintain a portion of the public right-of-way for **one (1) awning(s)** for
BEAUTY BOX HAIR SALON & SPA, adjacent to the premises known as **2944 W. Diversey Ave.**.

Dear Alderman **Reynaldo Colon**:

The applicant referenced above has requested the use of the public right-of-way for a **awning(s)**. An ordinance has been prepared by the Department of Business Affairs and Consumer Protection – Small Business Center - Public Way Use Unit for presentation to the City Council. Because this request was made for properties located in your ward, as approved by you as per the attached, I respectfully request that you introduce the attached ordinance at the next City Council meeting.

If you have any questions regarding this ordinance, please contact Anthony Bertuca at (312) 744-5506.

Department of Business Affairs and Consumer Protection



City of Chicago



O2014-4515

Office of the City Clerk

Document Tracking Sheet

| | |
|---------------------------------|--|
| Meeting Date: | 5/28/2014 |
| Sponsor(s): | Colón (35) |
| Type: | Ordinance |
| Title: | Awning(s) for Carniceria La Mejor, Inc. |
| Committee(s) Assignment: | Committee on Transportation and Public Way |

ORDINANCE
CARNICERIA LA MEJOR, INC.
Acct. No. 313985 - 1
Permit No. 1112657

Be It Ordained by the City Council of the City of Chicago:

SECTION 1. Permission and authority are hereby given and granted to CARNICERIA LA MEJOR, INC., upon the terms and subject to the conditions of this ordinance to maintain and use, as now constructed, one (1) Awning(s) projecting over the public right-of-way adjacent to its premises known as 2848 N. Milwaukee Ave..

Said Awning(s) at N. MILWAUKEE measure(s):

One (1) at twenty-five (25) feet in length, and two point zero one (2.01) feet in width for a total of fifty point two five (50.25) square feet.

The location of said privilege shall be as shown on prints kept on file with the Department of Business Affairs and Consumer Protection and the Office of the City Clerk.

Said privilege shall be constructed in accordance with plans and specifications approved by the Zoning Department - Signs.

This grant of privilege in the public way shall be subject to the provisions of Section 10-28-015 and all other required provisions of the Municipal Code of Chicago.

The grantee shall pay to the City of Chicago as compensation for the privilege #1112657 herein granted the sum of fifty (\$50.00) per annum in advance.

A 25% penalty will be added for payments received after due date.

The permit holder agrees to hold the City of Chicago harmless for any damage, relocation or replacement costs associated with damage, relocation or removal of private property caused by the City performing work in the public way.

Authority herein given and granted for a period of five (5) years from and after 04/22/2014.

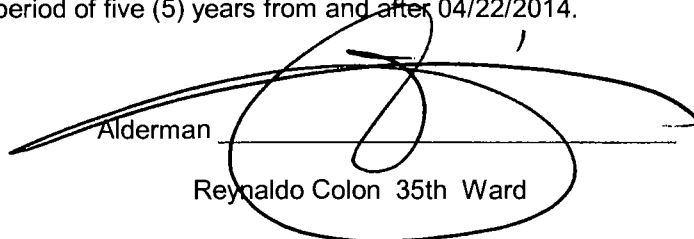
Alderman
Reynaldo Colon 35th Ward





05/28/2014

Alderman **Reynaldo Colon**
Ward # **35**
City of Chicago
City Hall, Room **203**
121 North LaSalle Street
Chicago, Illinois 60602

Re: An ordinance to use and maintain a portion of the public right-of-way for **one (1) awning(s)** for
CARNICERIA LA MEJOR, INC., adjacent to the premises known as **2848 N. Milwaukee Ave.**.

Dear Alderman **Reynaldo Colon**:

The applicant referenced above has requested the use of the public right-of-way for a **awning(s)**. An ordinance has been prepared by the Department of Business Affairs and Consumer Protection – Small Business Center - Public Way Use Unit for presentation to the City Council. Because this request was made for properties located in your ward, as approved by you as per the attached, I respectfully request that you introduce the attached ordinance at the next City Council meeting.

If you have any questions regarding this ordinance, please contact Anthony Bertuca at (312) 744-5506.

Department of Business Affairs and Consumer Protection



City of Chicago



O2014-4519

Office of the City Clerk

Document Tracking Sheet

| | |
|---------------------------------|--|
| Meeting Date: | 5/28/2014 |
| Sponsor(s): | Colón (35) |
| Type: | Ordinance |
| Title: | Awning(s) for Chuck's & Ed's Tavern |
| Committee(s) Assignment: | Committee on Transportation and Public Way |

ORDINANCE
CHUCK'S & ED'S TAVERN
Acct. No. 25991 - 1
Permit No. 1113027

Be It Ordained by the City Council of the City of Chicago:

SECTION 1. Permission and authority are hereby given and granted to CHUCK'S & ED'S TAVERN, upon the terms and subject to the conditions of this ordinance to maintain and use, as now constructed, two (2) Awning(s) projecting over the public right-of-way adjacent to its premises known as 3556 W. Belmont Ave..

Said Awning(s) at W. BELMONT measure(s):

One (1) at twenty-three (23) feet in length, and three point three three (3.33) feet in width for a total of seventy-six point five nine (76.59) square feet.

Said Awning(s) at N. CENTRAL PARK measure(s):

One (1) at seven (7) feet in length, and three (3) feet in width for a total of twenty-one (21) square feet.

The location of said privilege shall be as shown on prints kept on file with the Department of Business Affairs and Consumer Protection and the Office of the City Clerk.

Said privilege shall be constructed in accordance with plans and specifications approved by the Zoning Department - Signs.

This grant of privilege in the public way shall be subject to the provisions of Section 10-28-015 and all other required provisions of the Municipal Code of Chicago.

The grantee shall pay to the City of Chicago as compensation for the privilege #1113027 herein granted the sum of one hundred (\$100.00) per annum in advance.

A 25% penalty will be added for payments received after due date.

The permit holder agrees to hold the City of Chicago harmless for any damage, relocation or replacement costs associated with damage, relocation or removal of private property caused by the City performing work in the public way.

Authority herein given and granted for a period of five (5) years from and after 04/22/2014.

Alderman
Reynaldo Colon 35th Ward

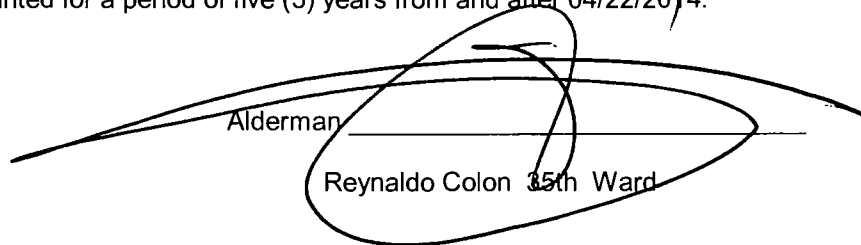

3556 W Belmont PWay

Created on: 2/9/2009 4:50 P.M.

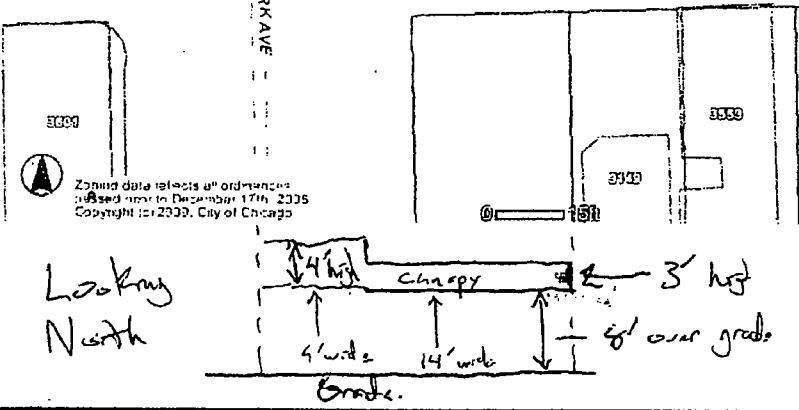
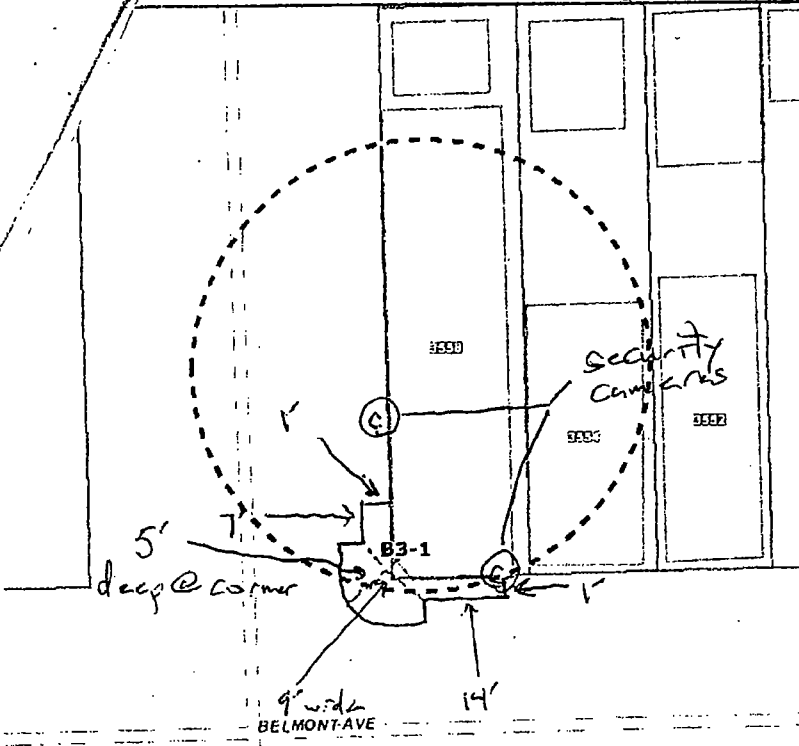

- Lake Front
- Zoning**
- Business
- Commercial
- Manufacturing
- Residential
- Planned Development
- Planned Manufacturing District
- Downtown Core
- Downtown Service
- Downtown Mixed
- Downtown Residential
- Transcription
- Parks & Open Space
- Zoning Boundaries
- Pedestrian Streets
- Buildings
- Parcels
- Streets
- Curbs
- Water
- Forest Preserve
- Cemetery
- City Boundary
- Municipalities

3556 W BELMONT AVE

Information provided on the City of Chicago web site should not be used as a substitute for legal, accounting, real estate, business, tax, or other professional advice. The City of Chicago assumes no liability for any damages or loss of any kind that might arise from the use of, misuse of, or the inability to use the City web site and/or the materials contained on the web site. The City of Chicago also assumes no liability for improper or incorrect use of materials or information contained on its web site. All materials that appear on the City of Chicago web site are distributed and transmitted as is, without warranties of any kind, either express or implied, and subject to the terms and conditions stated in this disclaimer.

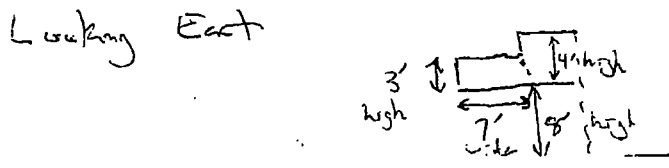



05/28/2014

Alderman **Reynaldo Colon**
Ward # **35**
City of Chicago
City Hall, Room **203**
121 North LaSalle Street
Chicago, Illinois 60602

Re: An ordinance to use and maintain a portion of the public right-of-way for **two (2) awning(s)** for
CHUCK'S & ED'S TAVERN, adjacent to the premises known as **3556 W. Belmont Ave.**

Dear Alderman **Reynaldo Colon**:

The applicant referenced above has requested the use of the public right-of-way for a **awning(s)**. An ordinance has been prepared by the Department of Business Affairs and Consumer Protection – Small Business Center - Public Way Use Unit for presentation to the City Council. Because this request was made for properties located in your ward, as approved by you as per the attached, I respectfully request that you introduce the attached ordinance at the next City Council meeting.

If you have any questions regarding this ordinance, please contact Anthony Bertuca at (312) 744-5506.

Department of Business Affairs and Consumer Protection



City of Chicago



O2014-4526

Office of the City Clerk

Document Tracking Sheet

| | |
|---------------------------------|--|
| Meeting Date: | 5/28/2014 |
| Sponsor(s): | Colón (35) |
| Type: | Ordinance |
| Title: | Awning(s) for Restaurant 2 Amigos |
| Committee(s) Assignment: | Committee on Transportation and Public Way |

ORDINANCE
RESTAURANT 2 AMIGOS
Acct. No. 4448 - 1
Permit No. 1113019

Be It Ordained by the City Council of the City of Chicago:

SECTION 1. Permission and authority are hereby given and granted to RESTAURANT 2 AMIGOS, upon the terms and subject to the conditions of this ordinance to maintain and use, as now constructed, one (1) Awning(s) projecting over the public right-of-way adjacent to its premises known as 2320 N. Milwaukee Ave..

Said Awning(s) at N. MILWAUKEE measure(s):

One (1) at thirty-six (36) feet in length, and eleven (11) feet in width for a total of three hundred ninety-six (396) square feet.

The location of said privilege shall be as shown on prints kept on file with the Department of Business Affairs and Consumer Protection and the Office of the City Clerk.

Said privilege shall be constructed in accordance with plans and specifications approved by the Zoning Department - Signs.

This grant of privilege in the public way shall be subject to the provisions of Section 10-28-015 and all other required provisions of the Municipal Code of Chicago.

The grantee shall pay to the City of Chicago as compensation for the privilege #1113019 herein granted the sum of sixty-one (\$61.00) per annum in advance.

A 25% penalty will be added for payments received after due date.

The permit holder agrees to hold the City of Chicago harmless for any damage, relocation or replacement costs associated with damage, relocation or removal of private property caused by the City performing work in the public way.

Authority herein given and granted for a period of five (5) years from and after 04/22/2014.

Alderman _____
Reynaldo Colon 35th Ward

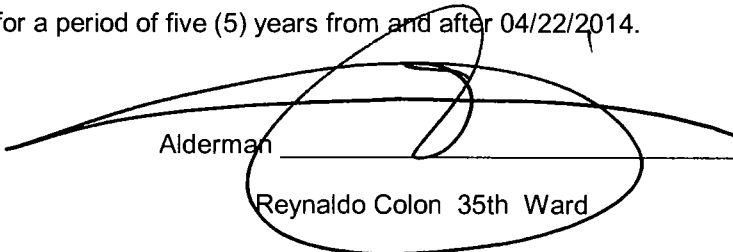
A large, stylized handwritten signature in black ink is written over the signature line. The signature is a complex, looping scribble that partially obscures the text 'Alderman' and 'Reynaldo Colon 35th Ward'.

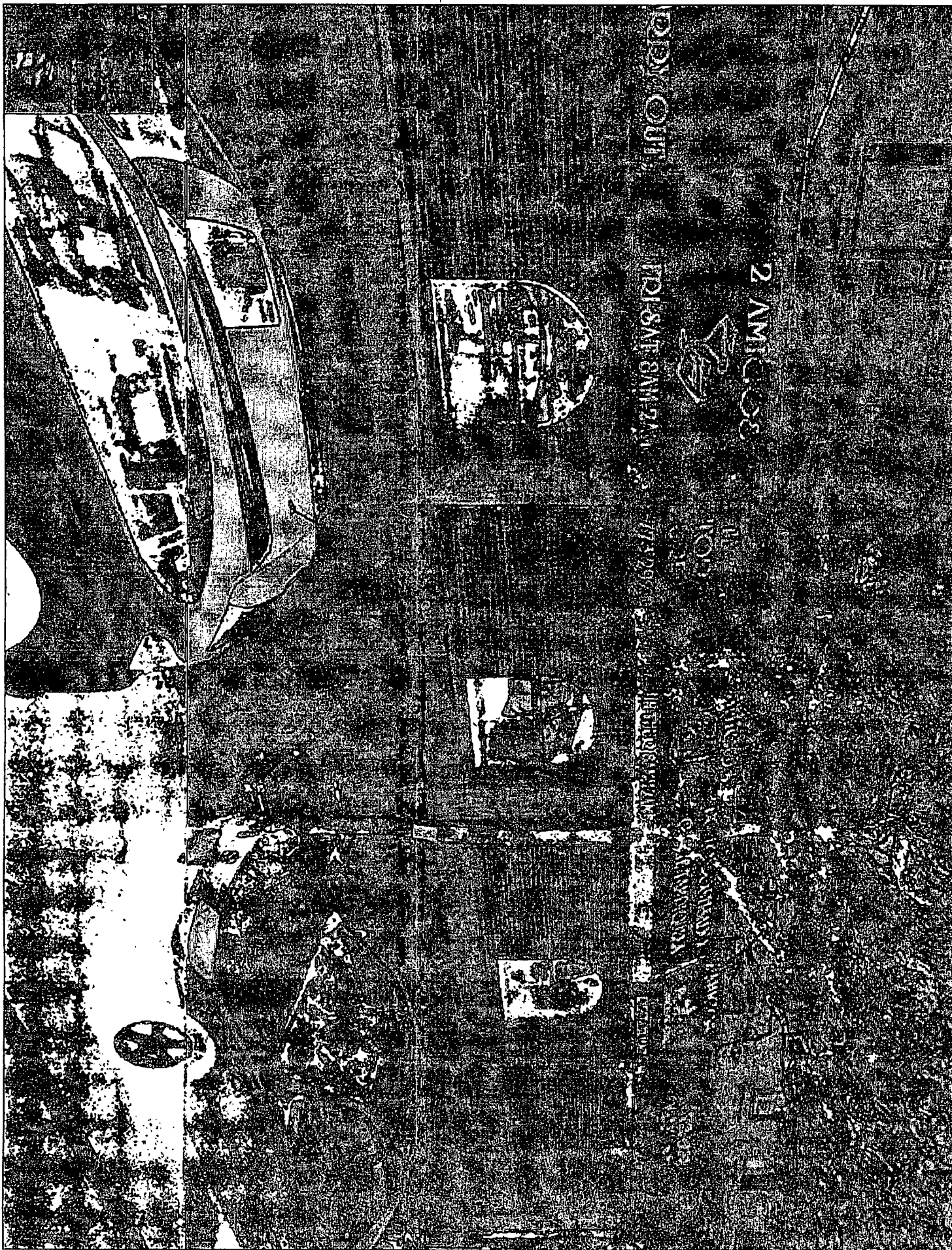



05/28/2014

Alderman **Reynaldo Colon**
Ward # 35
City of Chicago
City Hall, Room 203
121 North LaSalle Street
Chicago, Illinois 60602

Re: An ordinance to use and maintain a portion of the public right-of-way for **one (1) awning(s)** for **RESTAURANT 2 AMIGOS**, adjacent to the premises known as **2320 N. Milwaukee Ave.**

Dear Alderman **Reynaldo Colon**:

The applicant referenced above has requested the use of the public right-of-way for a **awning(s)**. An ordinance has been prepared by the Department of Business Affairs and Consumer Protection – Small Business Center - Public Way Use Unit for presentation to the City Council. Because this request was made for properties located in your ward, as approved by you as per the attached, I respectfully request that you introduce the attached ordinance at the next City Council meeting.

If you have any questions regarding this ordinance, please contact Anthony Bertuca at (312) 744-5506.

Department of Business Affairs and Consumer Protection



City of Chicago



O2014-4539

Office of the City Clerk

Document Tracking Sheet

| | |
|---------------------------------|--|
| Meeting Date: | 5/28/2014 |
| Sponsor(s): | Laurino (39) |
| Type: | Ordinance |
| Title: | Awning(s) for Pierre's Mini Detail Center |
| Committee(s) Assignment: | Committee on Transportation and Public Way |

ORDINANCE
Pierre's Mini Detail Center
Acct. No. 346860 - 1
Permit No. 1112989

Be It Ordained by the City Council of the City of Chicago:

SECTION 1. Permission and authority are hereby given and granted to Pierre's Mini Detail Center, upon the terms and subject to the conditions of this ordinance to maintain and use, as now constructed, one (1) Awning(s) projecting over the public right-of-way adjacent to its premises known as 4454 N. Elston Ave..

Said Awning(s) at N. Elston Avenue measure(s):

One (1) at forty (40) feet in length, and five (5) feet in width for a total of two hundred (200) square feet.

The location of said privilege shall be as shown on prints kept on file with the Department of Business Affairs and Consumer Protection and the Office of the City Clerk.

Said privilege shall be constructed in accordance with plans and specifications approved by the Zoning Department - Signs.

This grant of privilege in the public way shall be subject to the provisions of Section 10-28-015 and all other required provisions of the Municipal Code of Chicago.

The grantee shall pay to the City of Chicago as compensation for the privilege #1112989 herein granted the sum of sixty-five (\$65.00) per annum in advance.

A 25% penalty will be added for payments received after due date.

The permit holder agrees to hold the City of Chicago harmless for any damage, relocation or replacement costs associated with damage, relocation or removal of private property caused by the City performing work in the public way.

Authority herein given and granted for a period of five (5) years from and after 03/05/2014.

Alderman 
Margaret Laurino 39th Ward

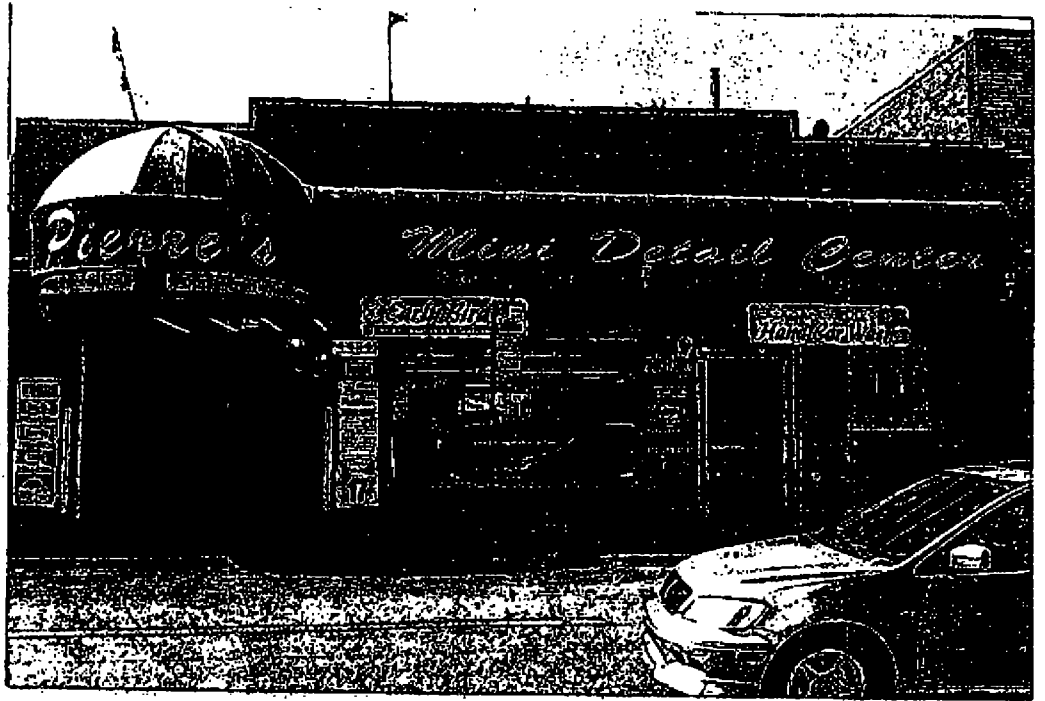



City of Chicago



O2014-4548

Office of the City Clerk

Document Tracking Sheet

| | |
|---------------------------------|--|
| Meeting Date: | 5/28/2014 |
| Sponsor(s): | O'Connor (40) |
| Type: | Ordinance |
| Title: | Awning(s) for Piatto Pronto |
| Committee(s) Assignment: | Committee on Transportation and Public Way |

ORDINANCE
PIATTO PRONTO
Acct. No. 319692 - 1
Permit No. 1113084

Be It Ordained by the City Council of the City of Chicago:

SECTION 1. Permission and authority are hereby given and granted to PIATTO PRONTO, upon the terms and subject to the conditions of this ordinance to maintain and use, as now constructed, one (1) Awning(s) projecting over the public right-of-way adjacent to its premises known as 5624 N. Clark St..

Said Awning(s) at N CLARK ST measure(s):

One (1) at twenty-five (25) feet in length, and four (4) feet in width for a total of one hundred (100) square feet.

The location of said privilege shall be as shown on prints kept on file with the Department of Business Affairs and Consumer Protection and the Office of the City Clerk.

Said privilege shall be constructed in accordance with plans and specifications approved by the Zoning Department - Signs.

This grant of privilege in the public way shall be subject to the provisions of Section 10-28-015 and all other required provisions of the Municipal Code of Chicago.

The grantee shall pay to the City of Chicago as compensation for the privilege #1113084 herein granted the sum of fifty (\$50.00) per annum in advance.

A 25% penalty will be added for payments received after due date.

The permit holder agrees to hold the City of Chicago harmless for any damage, relocation or replacement costs associated with damage, relocation or removal of private property caused by the City performing work in the public way.

Authority herein given and granted for a period of five (5) years from and after 04/22/2014.

Alderman

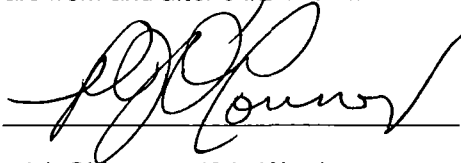

Patrick O'Connor 40th Ward

**PIATTO PRONTO
5634 N. CLARK St
CHICAGO IL 60660**



25'

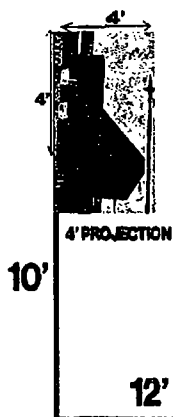
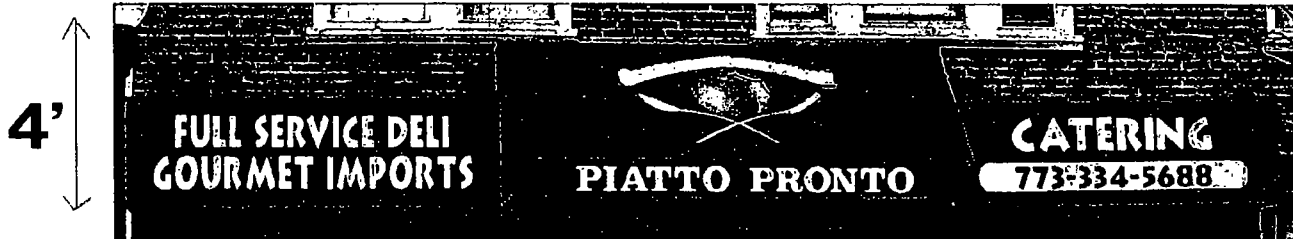

- 4' x 25' AWNING
- 12' SIDE WALK
- 10' FROM GRADE
- 4' PROJECTION



05/28/2014

Alderman **Patrick O'Connor**
Ward # **40**
City of Chicago
City Hall, Room **305**
121 North LaSalle Street
Chicago, Illinois 60602

Re: An ordinance to use and maintain a portion of the public right-of-way for **one (1) awning(s)** for **PIATTO PRONTO**, adjacent to the premises known as **5624 N. Clark St.**

Dear Alderman **Patrick O'Connor**:

The applicant referenced above has requested the use of the public right-of-way for a **awning(s)**. An ordinance has been prepared by the Department of Business Affairs and Consumer Protection – Small Business Center - Public Way Use Unit for presentation to the City Council. Because this request was made for properties located in your ward, as approved by you as per the attached, I respectfully request that you introduce the attached ordinance at the next City Council meeting.

If you have any questions regarding this ordinance, please contact Anthony Bertuca at (312) 744-5506.

Department of Business Affairs and Consumer Protection



City of Chicago



O2014-4552

Office of the City Clerk

Document Tracking Sheet

| | |
|---------------------------------|--|
| Meeting Date: | 5/28/2014 |
| Sponsor(s): | O'Connor (40) |
| Type: | Ordinance |
| Title: | Awning(s) for Subway |
| Committee(s) Assignment: | Committee on Transportation and Public Way |

ORDINANCE
SUBWAY
Acct. No. 7490 - 1
Permit No. 1112992

Be It Ordained by the City Council of the City of Chicago:

SECTION 1. Permission and authority are hereby given and granted to SUBWAY, upon the terms and subject to the conditions of this ordinance to maintain and use, as now constructed, one (1) Awning(s) projecting over the public right-of-way adjacent to its premises known as 6555 N. Clark St..

Said Awning(s) at N CLARK ST measure(s):

One (1) at eleven point nine two (11.92) feet in length, and four (4) feet in width for a total of forty-seven point six eight (47.68) square feet.

The location of said privilege shall be as shown on prints kept on file with the Department of Business Affairs and Consumer Protection and the Office of the City Clerk.

Said privilege shall be constructed in accordance with plans and specifications approved by the Zoning Department - Signs.

This grant of privilege in the public way shall be subject to the provisions of Section 10-28-015 and all other required provisions of the Municipal Code of Chicago.

The grantee shall pay to the City of Chicago as compensation for the privilege #1112992 herein granted the sum of fifty (\$50.00) per annum in advance.

A 25% penalty will be added for payments received after due date.

The permit holder agrees to hold the City of Chicago harmless for any damage, relocation or replacement costs associated with damage, relocation or removal of private property caused by the City performing work in the public way.

Authority herein given and granted for a period of five (5) years from and after 03/18/2014.

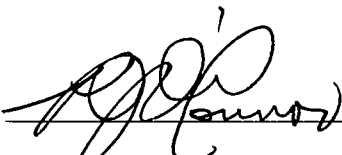
Alderman  _____
Patrick O'Connor 40th Ward

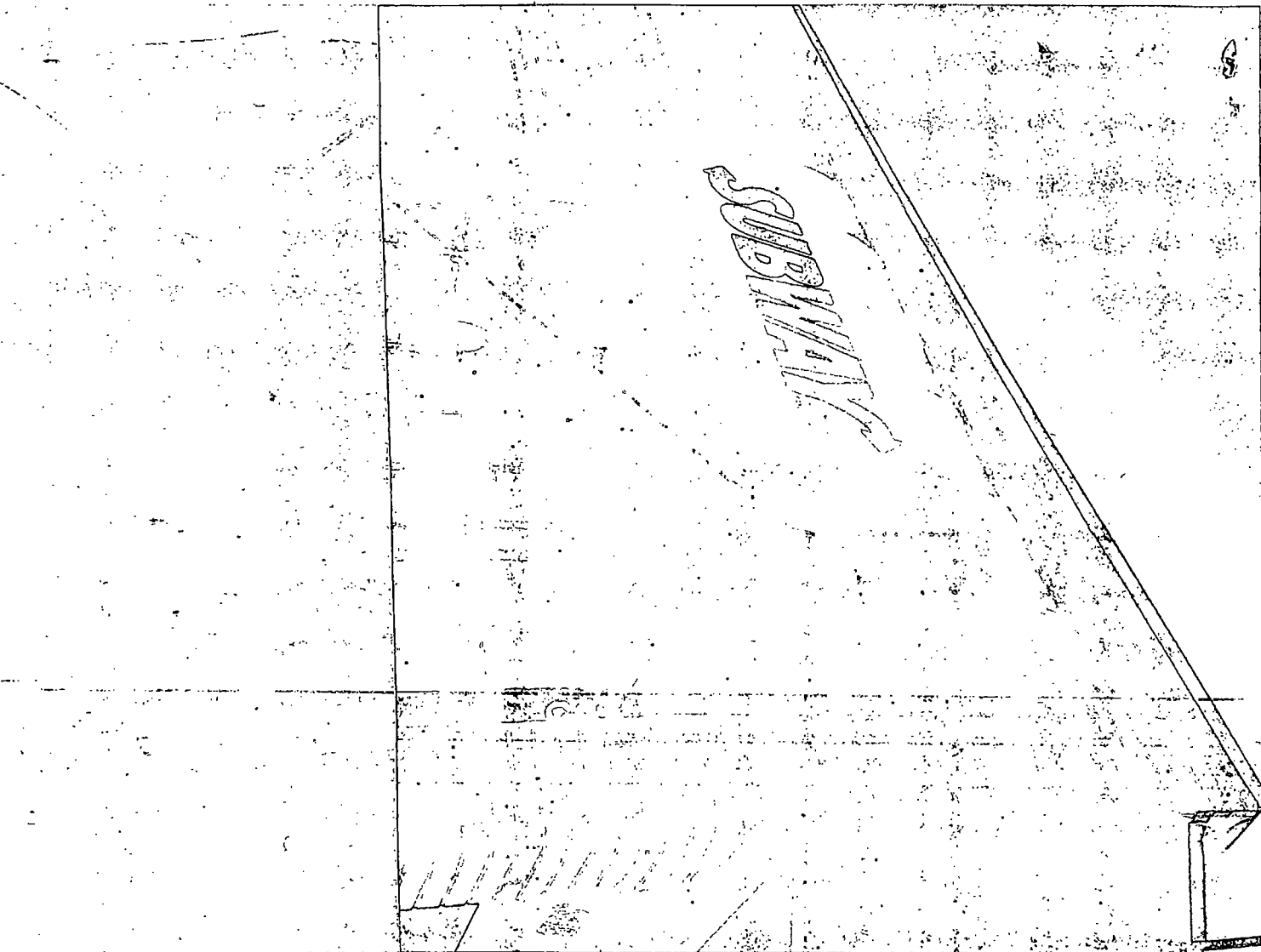



05/28/2014

Alderman **Patrick O'Connor**
Ward # 40
City of Chicago
City Hall, Room 305
121 North LaSalle Street
Chicago, Illinois 60602

Re: An ordinance to use and maintain a portion of the public right-of-way for **one (1) awning(s)** for **SUBWAY**, adjacent to the premises known as **6555 N. Clark St.**

Dear Alderman **Patrick O'Connor**:

The applicant referenced above has requested the use of the public right-of-way for a **awning(s)**. An ordinance has been prepared by the Department of Business Affairs and Consumer Protection – Small Business Center - Public Way Use Unit for presentation to the City Council. Because this request was made for properties located in your ward, as approved by you as per the attached, I respectfully request that you introduce the attached ordinance at the next City Council meeting.

If you have any questions regarding this ordinance, please contact Anthony Bertuca at (312) 744-5506.

Department of Business Affairs and Consumer Protection



City of Chicago

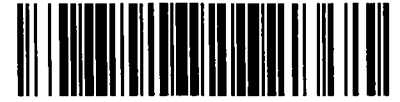

O2014-4561

Office of the City Clerk

Document Tracking Sheet

| | |
|---------------------------------|--|
| Meeting Date: | 5/28/2014 |
| Sponsor(s): | O'Connor (41) |
| Type: | Ordinance |
| Title: | Awning(s) for Ernest Cheirgalos |
| Committee(s) Assignment: | Committee on Transportation and Public Way |

ORDINANCE
ERNEST CHEIRGALOS
Acct. No. 339852 - 2
Permit No. 1113089

Be It Ordained by the City Council of the City of Chicago:

SECTION 1. Permission and authority are hereby given and granted to ERNEST CHEIRGALOS, upon the terms and subject to the conditions of this ordinance to maintain and use, as now constructed, two (2) Awning(s) projecting over the public right-of-way adjacent to its premises known as 6401-03 N. Caldwell Ave..

Said Awning(s) at N. Caldwell measure(s):

One (1) at twenty-seven point five (27.5) feet in length, and three point five (3.5) feet in width for a total of ninety-six point two five (96.25) square feet.

Said Awning(s) at N. Caldwell measure(s):

One (1) at six point five (6.5) feet in length, and three point five (3.5) feet in width for a total of twenty-two point seven five (22.75) square feet.

The location of said privilege shall be as shown on prints kept on file with the Department of Business Affairs and Consumer Protection and the Office of the City Clerk.

Said privilege shall be constructed in accordance with plans and specifications approved by the Zoning Department - Signs.

This grant of privilege in the public way shall be subject to the provisions of Section 10-28-015 and all other required provisions of the Municipal Code of Chicago.

The grantee shall pay to the City of Chicago as compensation for the privilege #1113089 herein granted the sum of one hundred two dollars and fifty cents (\$102.50) per annum in advance.

A 25% penalty will be added for payments received after due date.

The permit holder agrees to hold the City of Chicago harmless for any damage, relocation or replacement costs associated with damage, relocation or removal of private property caused by the City performing work in the public way.

Authority herein given and granted for a period of five (5) years from and after 03/18/2014.

Alderman 

Mary O'Connor 41st Ward

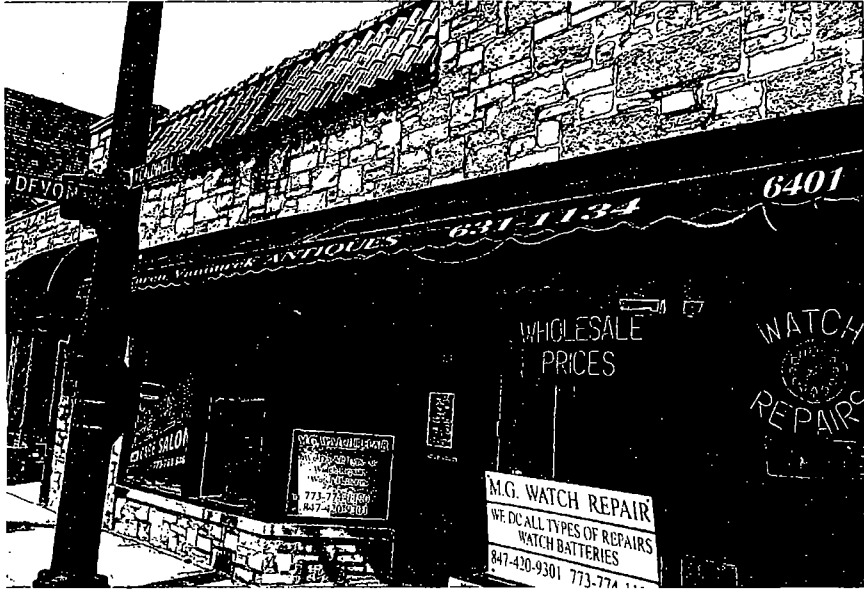



05/28/2014

Alderman **Mary O'Connor**
Ward # **41**
City of Chicago
City Hall, Room **203**
121 North LaSalle Street
Chicago, Illinois 60602

Re: An ordinance to use and maintain a portion of the public right-of-way for **two (2) awning(s)** for **ERNEST CHEIRGALOS**, adjacent to the premises known as **6401-03 N. Caldwell Ave.**.

Dear Alderman **Mary O'Connor**:

The applicant referenced above has requested the use of the public right-of-way for a **awning(s)**. An ordinance has been prepared by the Department of Business Affairs and Consumer Protection – Small Business Center - Public Way Use Unit for presentation to the City Council. Because this request was made for properties located in your ward, as approved by you as per the attached, I respectfully request that you introduce the attached ordinance at the next City Council meeting.

If you have any questions regarding this ordinance, please contact Anthony Bertuca at (312) 744-5506.

Department of Business Affairs and Consumer Protection



City of Chicago



O2014-4565

Office of the City Clerk

Document Tracking Sheet

| | |
|---------------------------------|---|
| Meeting Date: | 5/28/2014 |
| Sponsor(s): | O'Connor (41) |
| Type: | Ordinance |
| Title: | Awning(s) for Le Flour Bake Shop & Market, Inc. |
| Committee(s) Assignment: | Committee on Transportation and Public Way |

ORDINANCE
LE FLOUR BAKE SHOP & MARKET INC.
Acct. No. 339003 - 1
Permit No. 1113154

Be It Ordained by the City Council of the City of Chicago:

SECTION 1. Permission and authority are hereby given and granted to LE FLOUR BAKE SHOP & MARKET INC., upon the terms and subject to the conditions of this ordinance to maintain and use, as now constructed, three (3) Awning(s) projecting over the public right-of-way adjacent to its premises known as 6701 N. Olmsted Ave..

Said Awning(s) at N OLMSTED AVE measure(s):

One (1) at ten point five (10.5) feet in length, and four (4) feet in width for a total of forty-two (42) square feet.

Said Awning(s) at N OLMSTED AVE measure(s):

One (1) at six (6) feet in length, and four (4) feet in width for a total of twenty-four (24) square feet.

Said Awning(s) at N OLMSTED AVE measure(s):

One (1) at seven point two five (7.25) feet in length, and four (4) feet in width for a total of twenty-nine (29) square feet.

The location of said privilege shall be as shown on prints kept on file with the Department of Business Affairs and Consumer Protection and the Office of the City Clerk.

Said privilege shall be constructed in accordance with plans and specifications approved by the Zoning Department - Signs.

This grant of privilege in the public way shall be subject to the provisions of Section 10-28-015 and all other required provisions of the Municipal Code of Chicago.

The grantee shall pay to the City of Chicago as compensation for the privilege #1113154 herein granted the sum of one hundred fifty (\$150.00) per annum in advance.

A 25% penalty will be added for payments received after due date.

The permit holder agrees to hold the City of Chicago harmless for any damage, relocation or replacement costs associated with damage, relocation or removal of private property caused by the City performing work in the public way.

Authority herein given and granted for a period of five (5) years from and after 04/22/2014.

Alderman



Mary O'Connor 41st Ward

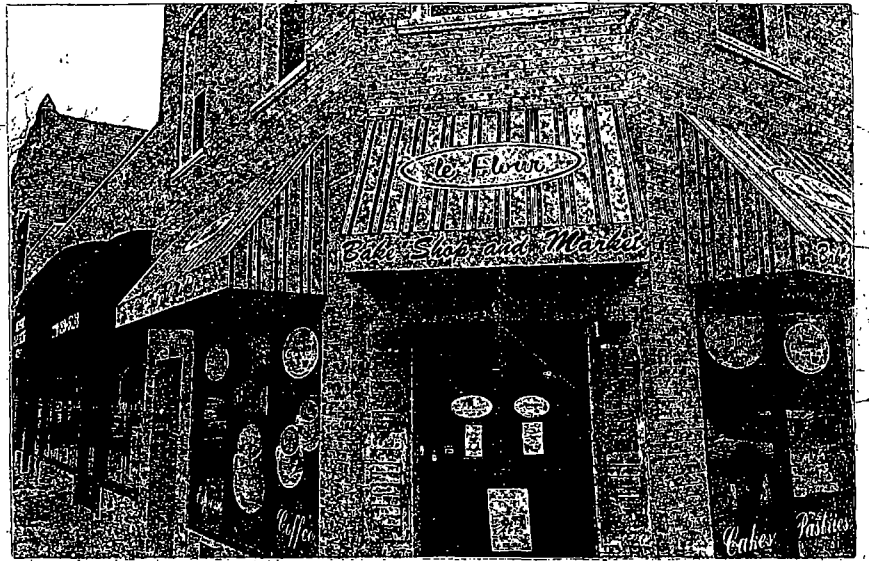



05/28/2014

Alderman **Mary O'Connor**
Ward # **41**
City of Chicago
City Hall, Room **203**
121 North LaSalle Street
Chicago, Illinois 60602

Re: An ordinance to use and maintain a portion of the public right-of-way for **three (3) awning(s)** for **LE FLOUR BAKE SHOP & MARKET INC.**, adjacent to the premises known as **6701 N. Olmsted Ave.**.

Dear Alderman **Mary O'Connor**:

The applicant referenced above has requested the use of the public right-of-way for a **awning(s)**. An ordinance has been prepared by the Department of Business Affairs and Consumer Protection – Small Business Center - Public Way Use Unit for presentation to the City Council. Because this request was made for properties located in your ward, as approved by you as per the attached, I respectfully request that you introduce the attached ordinance at the next City Council meeting.

If you have any questions regarding this ordinance, please contact Anthony Bertuca at (312) 744-5506.

Department of Business Affairs and Consumer Protection



City of Chicago



O2014-4566

Office of the City Clerk

Document Tracking Sheet

| | |
|---------------------------------|--|
| Meeting Date: | 5/28/2014 |
| Sponsor(s): | Reilly (42) |
| Type: | Ordinance |
| Title: | Awning(s) for Argo Tea |
| Committee(s) Assignment: | Committee on Transportation and Public Way |

ORDINANCE
ARGO TEA
Acct. No. 290070 - 1
Permit No. 1112869

Be It Ordained by the City Council of the City of Chicago:

SECTION 1. Permission and authority are hereby given and granted to ARGO TEA, upon the terms and subject to the conditions of this ordinance to maintain and use, as now constructed, one (1) Awning(s) projecting over the public right-of-way adjacent to its premises known as 16 W. Randolph St..

Said Awning(s) at W. Randolph St. measure(s):

One (1) at eight point five (8.5) feet in length, and sixteen (16) feet in width for a total of one hundred thirty-six (136) square feet.

The location of said privilege shall be as shown on prints kept on file with the Department of Business Affairs and Consumer Protection and the Office of the City Clerk.

Said privilege shall be constructed in accordance with plans and specifications approved by the Zoning Department - Signs.

This grant of privilege in the public way shall be subject to the provisions of Section 10-28-015 and all other required provisions of the Municipal Code of Chicago.

The grantee shall pay to the City of Chicago as compensation for the privilege #1112869 herein granted the sum of fifty (\$50.00) per annum in advance.

A 25% penalty will be added for payments received after due date.

The permit holder agrees to hold the City of Chicago harmless for any damage, relocation or replacement costs associated with damage, relocation or removal of private property caused by the City performing work in the public way.

Authority herein given and granted for a period of five (5) years from and after 01/11/2014.

Alderman _____

Brendan Reilly 42nd Ward

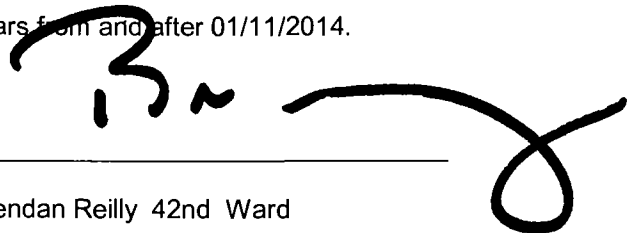

10-15-19

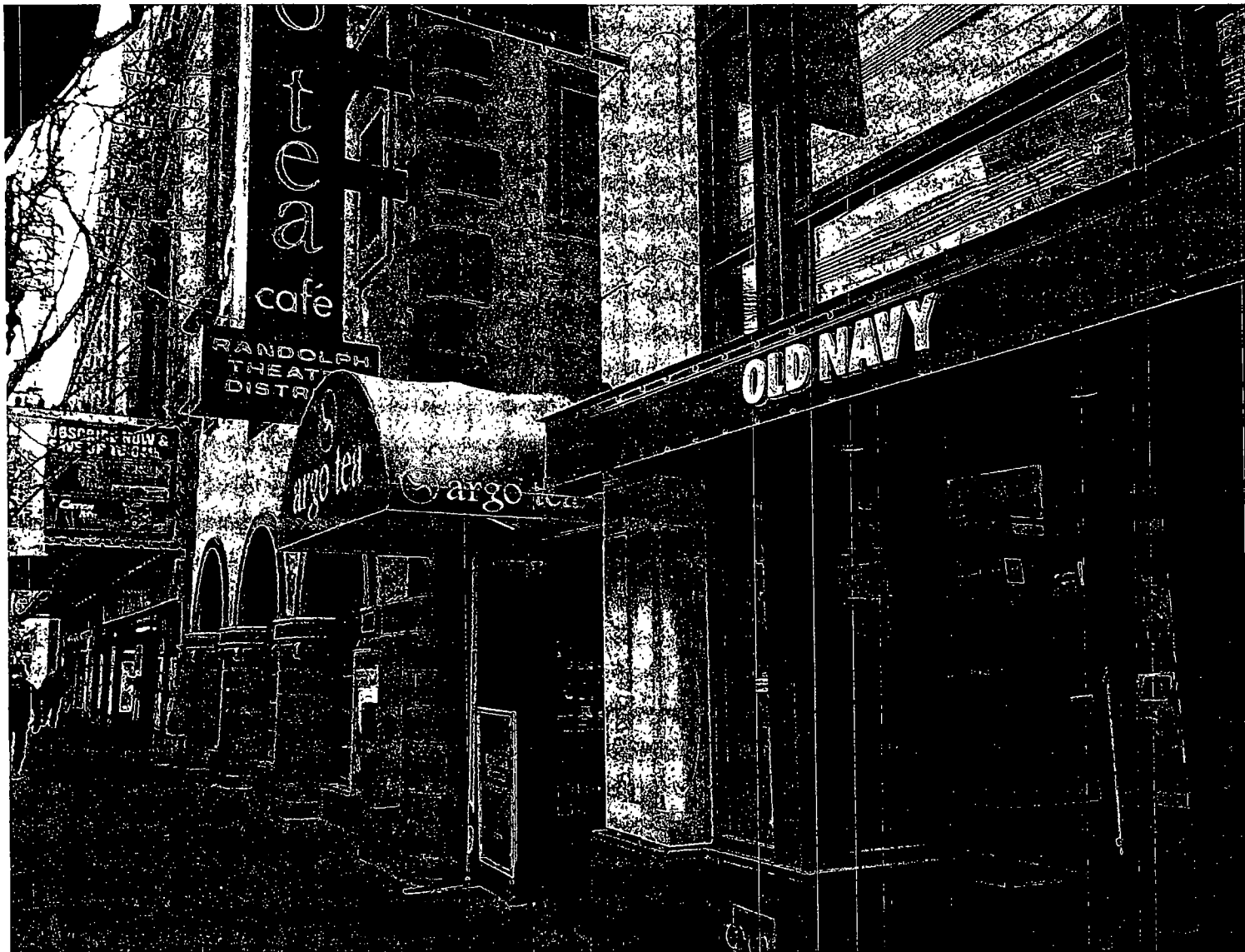



City of Chicago



O2014-4573

Office of the City Clerk

Document Tracking Sheet

| | |
|---------------------------------|--|
| Meeting Date: | 5/28/2014 |
| Sponsor(s): | Reilly (42) |
| Type: | Ordinance |
| Title: | Awning(s) for Bedazzled Nails & Spa, Inc. |
| Committee(s) Assignment: | Committee on Transportation and Public Way |

ORDINANCE
BEDAZZLED NAILS & SPA, INC.
Acct. No. 387656 - 1
Permit No. 1113051

Be It Ordained by the City Council of the City of Chicago:

SECTION 1. Permission and authority are hereby given and granted to BEDAZZLED NAILS & SPA, INC., upon the terms and subject to the conditions of this ordinance to construct, install, maintain and use one (1) Awning(s) projecting over the public right-of-way adjacent to its premises known as 543 N. St Clair St..

Said Awning(s) at St. Clair measure(s):

One (1) at ten (10) feet in length, and three point five (3.5) feet in width for a total of thirty-five (35) square feet.

The location of said privilege shall be as shown on prints kept on file with the Department of Business Affairs and Consumer Protection and the Office of the City Clerk.

Said privilege shall be constructed in accordance with plans and specifications approved by the Zoning Department - Signs.

This grant of privilege in the public way shall be subject to the provisions of Section 10-28-015 and all other required provisions of the Municipal Code of Chicago.

The grantee shall pay to the City of Chicago as compensation for the privilege #1113051 herein granted the sum of fifty (\$50.00) per annum in advance.

A 25% penalty will be added for payments received after due date.

The permit holder agrees to hold the City of Chicago harmless for any damage, relocation or replacement costs associated with damage, relocation or removal of private property caused by the City performing work in the public way.

Authority herein given and granted for a period of five (5) years from and after Date of Passage.

Alderman _____

Brendan Reilly 42nd Ward

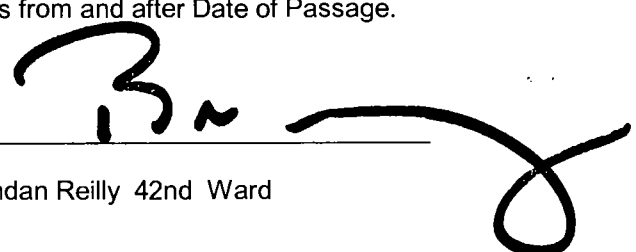
A large, stylized handwritten signature in black ink, appearing to be 'B. Reilly', written over a horizontal line. The signature is fluid and cursive, with a large loop at the end.

Handwritten scribbles or marks, possibly a signature or initials, located in the lower-left quadrant of the page.

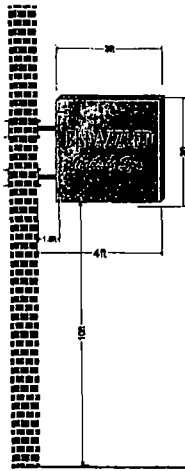

Walkway

Side VIEW

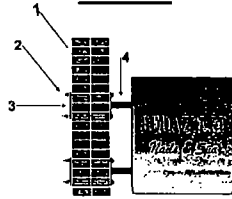

- 1 Wall / Building
- 2 1/2"x24" steel bolt
- 3 1/2" x 8"x12" steel plate
- 4 0.250x2"x2" pipe welded to steel plate

BY: MAY 03 2014

General Specifications

| | |
|----------------|-----------------------------|
| Sign Type | Nonilluminated sign cabinet |
| Retainer Size | 12.5" |
| Retainer Color | Black |
| Retainer gauge | 0.090 aluminum |
| Sign Style | Double face (projecting) |
| Face Color | Brush aluminum |
| Face Material | 1/8" aluminum |
| Vinyl Graphics | 3M Red |
| Lamp | Ballast N/A |
| Mounting | 1/2" x 16" Lag bolts |

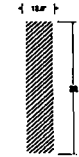

FRONT VIEW

Sign will be fastened directly to facade no exposed wiring



General Specifications

| | |
|-----------------------------|--------------------------------|
| Sign type | Nonilluminated Awning |
| Face material & | Sun Umbrella vinyl |
| Color back ground | Red with graphics colors |
| Frame construction material | 1"x1" galvanize tube welded |
| Gauge | .090 |
| Graphic | 3M Vinyl |
| Color of wording | White |
| Under awning cover Material | N/A |
| Transformer / Ballast | N/A |
| Powers input | N/A |
| Powers output | N/A |
| Neon / Lamps | N/A |
| Safety Switch | N/A |
| Boat insulated | N/A |
| GTO cable / Wire / Gauge | N/A |
| Electrical connectors | N/A |
| Retainer screw | #4 0.5" lg Hex hd "Bronze" |
| Mounting | 1/2" x 3" Lag screw w/ anchors |

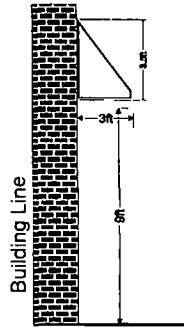

Side Walk

CUSTOMER: Bedazzled Nails & Spa
 LOCATION: 543 N Saint Clair St
 Chicago, IL 60611
 Design By: BV
 Date: 04/03/2014

Customer approval signature _____ / / 2014
 Date
 / / 2014
 Date
© by Express Sign
 Proprietary and Confidential
 This design is the original and unaltered work of Express Sign & Graphics, Inc. and may not be reproduced, copied or emulated in any fashion without the expressed writing from an authorized personnel of the company. The rights to this design may be purchased.

Special Note: REVISED
 This is an existing sign & canopy we only apply permits
 _____ / / 2014
 Date
 Landlord approval signature _____ / / 2014
 Date



City of Chicago



O2014-4576

Office of the City Clerk Document Tracking Sheet

| | |
|---------------------------------|--|
| Meeting Date: | 5/28/2014 |
| Sponsor(s): | Reilly (42) |
| Type: | Ordinance |
| Title: | Awning(s) for Hangge-Uppe, Inc., The |
| Committee(s) Assignment: | Committee on Transportation and Public Way |

ORDINANCE
THE HANGGE- UPPE, INC.
Acct. No. 2679 - 1
Permit No. 1112967

Be It Ordained by the City Council of the City of Chicago:

SECTION 1. Permission and authority are hereby given and granted to THE HANGGE- UPPE, INC., upon the terms and subject to the conditions of this ordinance to maintain and use, as now constructed, two (2) Awning(s) projecting over the public right-of-way adjacent to its premises known as 14 W. Elm St..

Said Awning(s) at W. Elm Street measure(s):

One (1) at thirty-three (33) feet in length, and four (4) feet in width for a total of one hundred thirty-two (132) square feet.

One (1) at thirteen (13) feet in length, and ten (10) feet in width for a total of one hundred thirty (130) square feet.

The location of said privilege shall be as shown on prints kept on file with the Department of Business Affairs and Consumer Protection and the Office of the City Clerk.

Said privilege shall be constructed in accordance with plans and specifications approved by the Zoning Department - Signs.

This grant of privilege in the public way shall be subject to the provisions of Section 10-28-015 and all other required provisions of the Municipal Code of Chicago.

The grantee shall pay to the City of Chicago as compensation for the privilege #1112967 herein granted the sum of one hundred eight (\$108.00) per annum in advance.

A 25% penalty will be added for payments received after due date.

The permit holder agrees to hold the City of Chicago harmless for any damage, relocation or replacement costs associated with damage, relocation or removal of private property caused by the City performing work in the public way.

Authority herein given and granted for a period of five (5) years from and after 03/18/2014.

Alderman _____

Brendan Reilly 42nd Ward

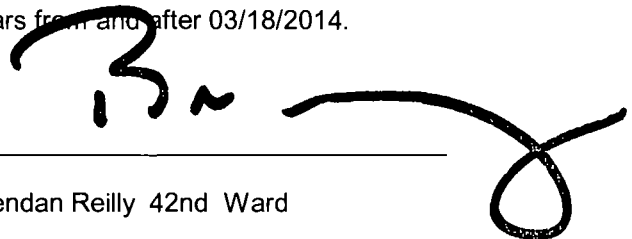
A large, stylized handwritten signature in black ink, appearing to read 'B. Reilly', is written over the signature line and extends to the right.

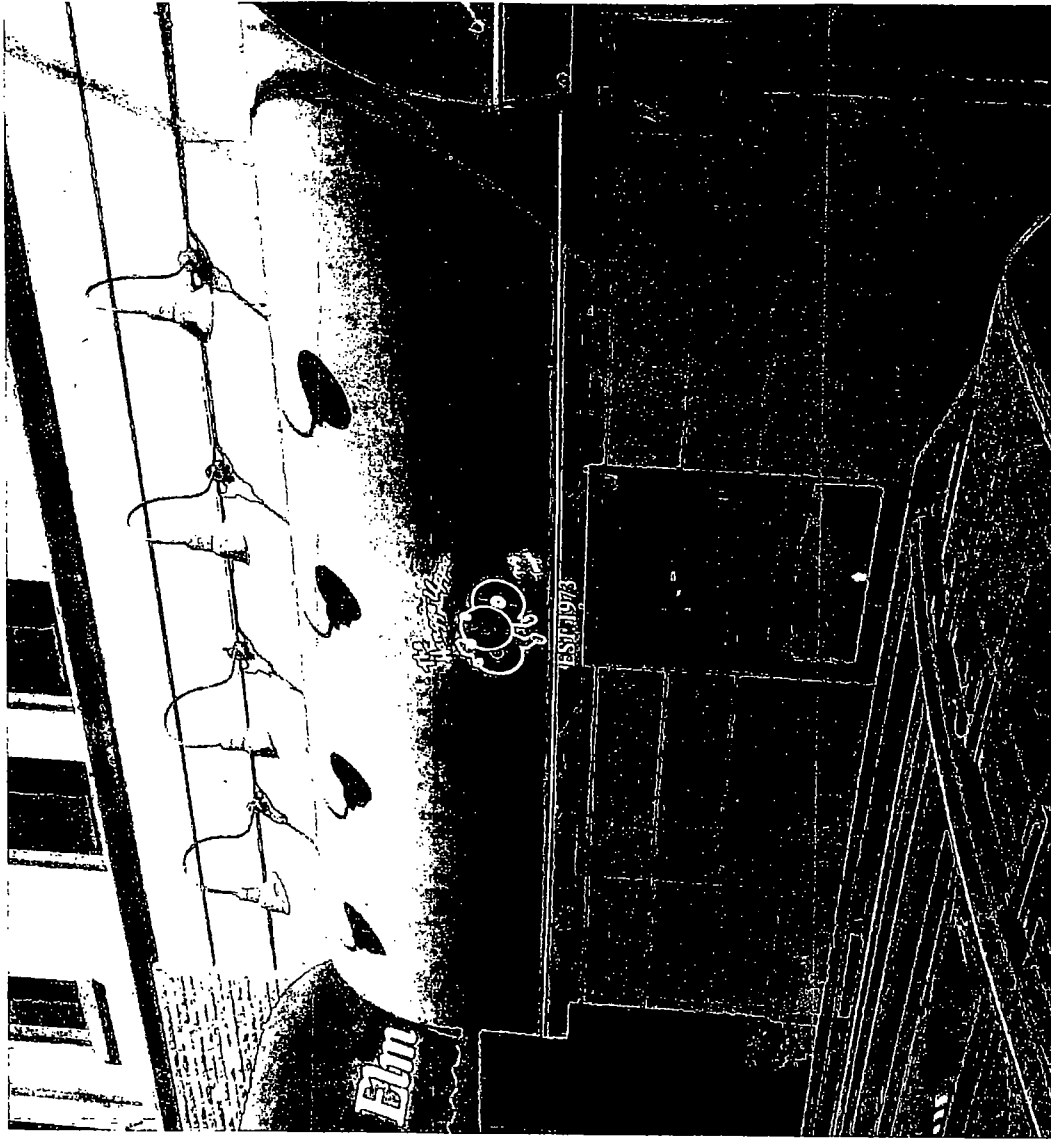



City of Chicago



O2014-4580

Office of the City Clerk Document Tracking Sheet

| | |
|---------------------------------|--|
| Meeting Date: | 5/28/2014 |
| Sponsor(s): | Reilly (42) |
| Type: | Ordinance |
| Title: | Awning(s) for Hotel Allegro |
| Committee(s) Assignment: | Committee on Transportation and Public Way |

ORDINANCE
HOTEL ALLEGRO
Acct. No. 314818 - 1
Permit No. 1112830

Be It Ordained by the City Council of the City of Chicago:

SECTION 1. Permission and authority are hereby given and granted to HOTEL ALLEGRO, upon the terms and subject to the conditions of this ordinance to maintain and use, as now constructed, twelve (12) Awning(s) projecting over the public right-of-way adjacent to its premises known as 171 W. Randolph St..

Said Awning(s) at W RANDOLPH ST measure(s):

One (1) at twenty (20) feet in length, and ten point two five (10.25) feet in width for a total of two hundred five (205) square feet.

Said Awning(s) at W RANDOLPH ST measure(s):

One (1) at twenty (20) feet in length, and ten point two five (10.25) feet in width for a total of two hundred five (205) square feet.

Said Awning(s) at W RANDOLPH ST measure(s):

One (1) at twenty (20) feet in length, and ten point two five (10.25) feet in width for a total of two hundred five (205) square feet.

Said Awning(s) at W RANDOLPH ST measure(s):

One (1) at ten (10) feet in length, and ten point two five (10.25) feet in width for a total of one hundred two point five (102.5) square feet.

Said Awning(s) at W RANDOLPH ST measure(s):

One (1) at fifteen (15) feet in length, and ten point two five (10.25) feet in width for a total of one hundred fifty-three point seven five (153.75) square feet.

Said Awning(s) at N WELLS ST measure(s):

One (1) at fifteen (15) feet in length, and ten point two five (10.25) feet in width for a total of one hundred fifty-three point seven five (153.75) square feet.

Said Awning(s) at N WELLS ST measure(s):

One (1) at fifteen (15) feet in length, and ten point two five (10.25) feet in width for a total of one hundred fifty-three point seven five (153.75) square feet.

Said Awning(s) at W WELLS ST measure(s):

One (1) at fifteen (15) feet in length, and ten point two five (10.25) feet in width for a total of one hundred fifty-three point seven five (153.75) square feet.

Said Awning(s) at N WELLS ST measure(s):

One (1) at fifteen (15) feet in length, and ten point two five (10.25) feet in width for a total of one hundred fifty-three point seven five (153.75) square feet.

Said Awning(s) at N WELLS ST measure(s):

One (1) at fifteen (15) feet in length, and ten point two five (10.25) feet in width for a total of one hundred fifty-three point seven five (153.75) square feet.

Said Awning(s) at N WELLS ST measure(s):

One (1) at fifteen (15) feet in length, and ten point two five (10.25) feet in width for a total of one hundred fifty-three point seven five (153.75) square feet.

Said Awning(s) at N WELLS ST measure(s):

One (1) at twelve (12) feet in length, and ten point two five (10.25) feet in width for a total of one hundred twenty-three (123) square feet.

The location of said privilege shall be as shown on prints kept on file with the Department of Business Affairs and Consumer Protection and the Office of the City Clerk.

Said privilege shall be constructed in accordance with plans and specifications approved by the Zoning Department - Signs.

This grant of privilege in the public way shall be subject to the provisions of Section 10-28-015 and all other required provisions of the Municipal Code of Chicago.

The grantee shall pay to the City of Chicago as compensation for the privilege #1112830 herein granted the sum of one hundred seventy-five (\$175.00) per annum in advance.

A 25% penalty will be added for payments received after due date.

The permit holder agrees to hold the City of Chicago harmless for any damage, relocation or replacement costs associated with damage, relocation or removal of private property caused by the City performing work in the public way.

Authority herein given and granted for a period of five (5) years from and after 03/18/2014.

Alderman _____

Brendan Reilly 42nd Ward





City of Chicago



O2014-4589

Office of the City Clerk

Document Tracking Sheet

| | |
|---------------------------------|--|
| Meeting Date: | 5/28/2014 |
| Sponsor(s): | Reilly (42) |
| Type: | Ordinance |
| Title: | Awning(s) for Luxbar |
| Committee(s) Assignment: | Committee on Transportation and Public Way |

ORDINANCE
LUXBAR
Acct. No. 205630 - 1
Permit No. 1112897

Be It Ordained by the City Council of the City of Chicago:

SECTION 1. Permission and authority are hereby given and granted to LUXBAR, upon the terms and subject to the conditions of this ordinance to maintain and use, as now constructed, six (6) Awning(s) projecting over the public right-of-way adjacent to its premises known as 18-20 E. Bellevue Pl..

Said Awning(s) at E. Bellevue Place measure(s):

Four (4) at ten point seven (10.7) feet in length, and two (2) feet in width for a total of eighty-five point six (85.6) square feet.

Two (2) at fifteen point four (15.4) feet in length, and two (2) feet in width for a total of sixty-one point six (61.6) square feet.

The location of said privilege shall be as shown on prints kept on file with the Department of Business Affairs and Consumer Protection and the Office of the City Clerk.

Said privilege shall be constructed in accordance with plans and specifications approved by the Zoning Department - Signs.

This grant of privilege in the public way shall be subject to the provisions of Section 10-28-015 and all other required provisions of the Municipal Code of Chicago.

The grantee shall pay to the City of Chicago as compensation for the privilege #1112897 herein granted the sum of one hundred seventy-five (\$175.00) per annum in advance.

A 25% penalty will be added for payments received after due date.

The permit holder agrees to hold the City of Chicago harmless for any damage, relocation or replacement costs associated with damage, relocation or removal of private property caused by the City performing work in the public way.

Authority herein given and granted for a period of five (5) years from and after 05/24/2014.

Alderman _____

Brendan Reilly 42nd Ward

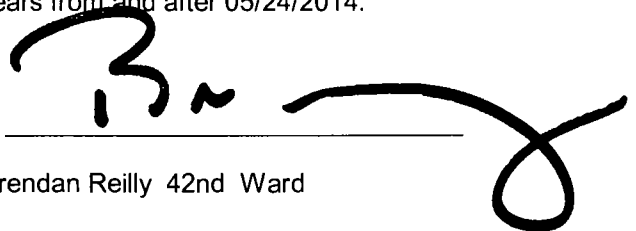

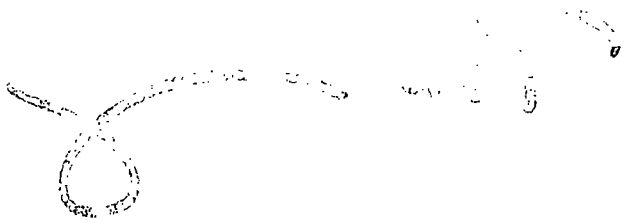

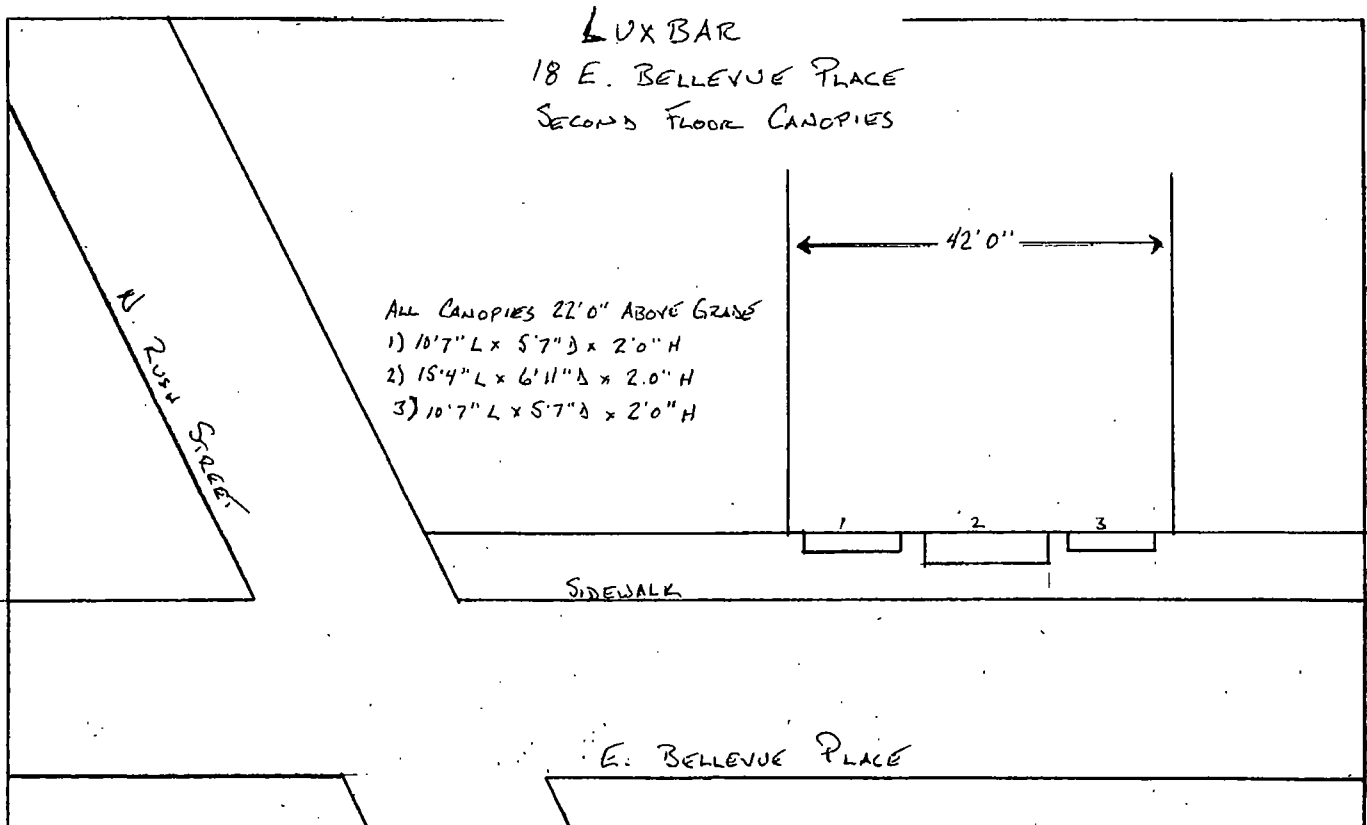
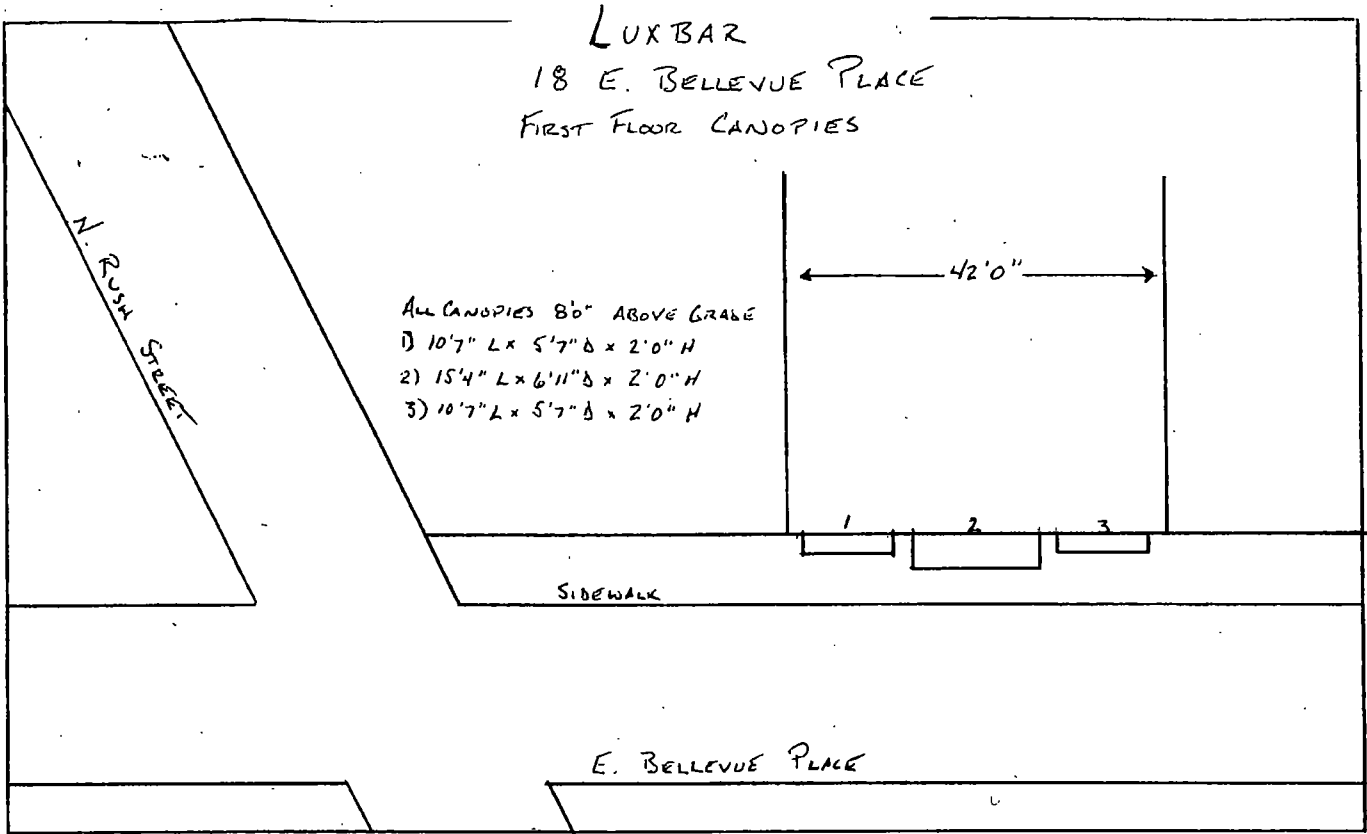



City of Chicago



O2014-4596

Office of the City Clerk

Document Tracking Sheet

| | |
|---------------------------------|---|
| Meeting Date: | 5/28/2014 |
| Sponsor(s): | Reilly (42) |
| Type: | Ordinance |
| Title: | Awning(s) for Maggiano's Little Italy - privilege No. 1112890 |
| Committee(s) Assignment: | Committee on Transportation and Public Way |

ORDINANCE
MAGGIANO'S LITTLE ITALY
Acct. No. 85312 - 2
Permit No. 1112890

Be It Ordained by the City Council of the City of Chicago:

SECTION 1. Permission and authority are hereby given and granted to MAGGIANO'S LITTLE ITALY, upon the terms and subject to the conditions of this ordinance to maintain and use, as now constructed, five (5) Awning(s) projecting over the public right-of-way adjacent to its premises known as 516 N. Clark St..

Said Awning(s) at N. Clark Street measure(s):

One (1) at thirteen point seven five (13.75) feet in length, and five (5) feet in width for a total of sixty-eight point seven five (68.75) square feet.

One (1) at thirteen point one seven (13.17) feet in length, and five (5) feet in width for a total of sixty-five point eight five (65.85) square feet.

One (1) at thirteen point eight three (13.83) feet in length, and five (5) feet in width for a total of sixty-nine point one five (69.15) square feet.

Said Awning(s) at W Grand Ave measure(s):

One (1) at seven point eight three (7.83) feet in length, and five (5) feet in width for a total of thirty-nine point one five (39.15) square feet.

One (1) at nineteen point two five (19.25) feet in length, and five (5) feet in width for a total of ninety-six point two five (96.25) square feet.

The location of said privilege shall be as shown on prints kept on file with the Department of Business Affairs and Consumer Protection and the Office of the City Clerk.

Said privilege shall be constructed in accordance with plans and specifications approved by the Zoning Department - Signs.

This grant of privilege in the public way shall be subject to the provisions of Section 10-28-015 and all other required provisions of the Municipal Code of Chicago.

The grantee shall pay to the City of Chicago as compensation for the privilege #1112890 herein granted the sum of one hundred seventy-five (\$175.00) per annum in advance.

A 25% penalty will be added for payments received after due date.

The permit holder agrees to hold the City of Chicago harmless for any damage, relocation or replacement costs associated with damage, relocation or removal of private property caused by the City performing work in the public way.

Authority herein given and granted for a period of five (5) years from and after 01/14/2014.

Alderman _____

Brendan Reilly 42nd Ward

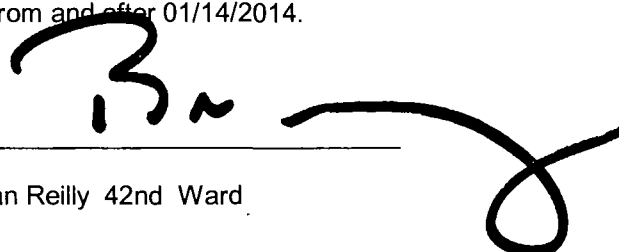

Handwritten scribble or signature.

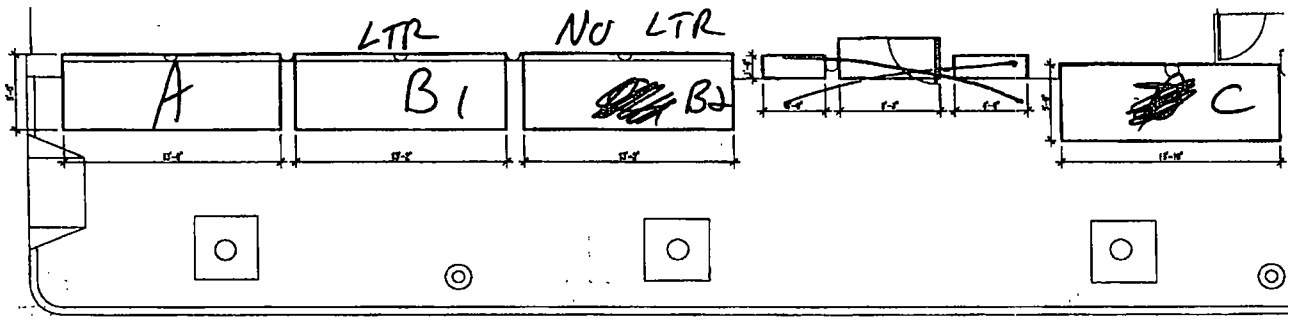

N. CLARK ST.

AWNINGS ON CLARK
1/8" = 1'0"



#47 Clark & Grand
Permit Renewal

04.10.2014
Page 1





City of Chicago



O2014-4600

Office of the City Clerk

Document Tracking Sheet

| | |
|---------------------------------|---|
| Meeting Date: | 5/28/2014 |
| Sponsor(s): | Reilly (42) |
| Type: | Ordinance |
| Title: | Awning(s) for Maggiano's Little Italy - privilege No. 1112891 |
| Committee(s) Assignment: | Committee on Transportation and Public Way |

ORDINANCE
MAGGIANO'S LITTLE ITALY
Acct. No. 85312 - 2
Permit No. 1112891

Be It Ordained by the City Council of the City of Chicago:

SECTION 1. Permission and authority are hereby given and granted to MAGGIANO'S LITTLE ITALY, upon the terms and subject to the conditions of this ordinance to maintain and use, as now constructed, four (4) Awning(s) projecting over the public right-of-way adjacent to its premises known as 516 N. Clark St..

Said Awning(s) at N. Clark Street measure(s):

One (1) at thirteen point one seven (13.17) feet in length, and five (5) feet in width for a total of sixty-five point eight five (65.85) square feet.

Said Awning(s) at W. Grand Avenue measure(s):

One (1) at nineteen point five eight (19.58) feet in length, and five (5) feet in width for a total of ninety-seven point nine (97.9) square feet.

One (1) at eight point zero eight (8.08) feet in length, and five (5) feet in width for a total of forty point four (40.4) square feet.

One (1) at nineteen point two five (19.25) feet in length, and five (5) feet in width for a total of ninety-six point two five (96.25) square feet.

The location of said privilege shall be as shown on prints kept on file with the Department of Business Affairs and Consumer Protection and the Office of the City Clerk.

Said privilege shall be constructed in accordance with plans and specifications approved by the Zoning Department - Signs.

This grant of privilege in the public way shall be subject to the provisions of Section 10-28-015 and all other required provisions of the Municipal Code of Chicago.

The grantee shall pay to the City of Chicago as compensation for the privilege #1112891 herein granted the sum of one hundred seventy-five (\$175.00) per annum in advance.

A 25% penalty will be added for payments received after due date.

The permit holder agrees to hold the City of Chicago harmless for any damage, relocation or replacement costs associated with damage, relocation or removal of private property caused by the City performing work in the public way.

Authority herein given and granted for a period of five (5) years from and after 01/14/2014.

Alderman _____

Brendan Reilly 42nd Ward

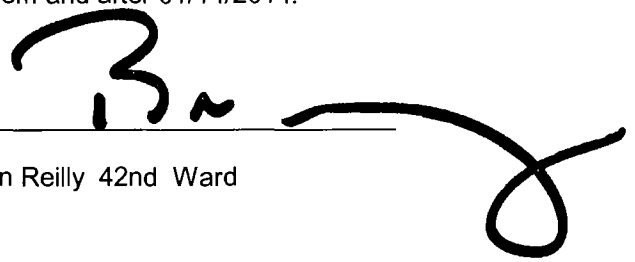

Handwritten scribbles or marks, possibly initials or a signature, located in the lower-left quadrant of the page.

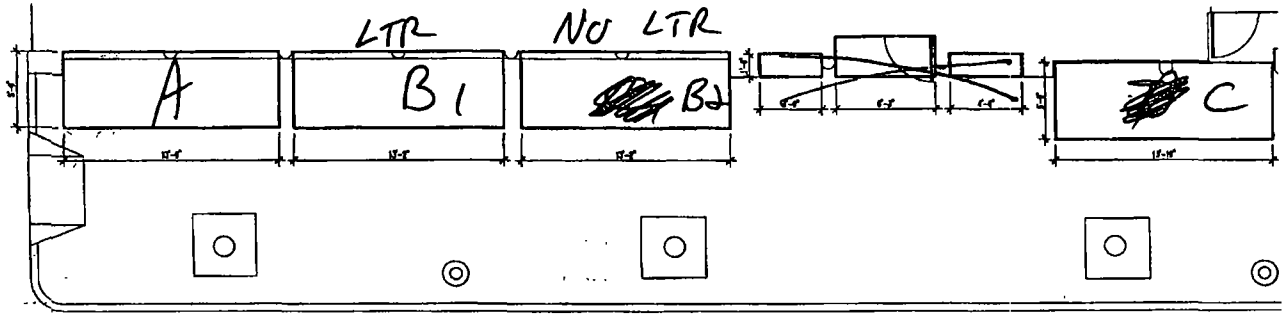

N. CLARK ST.

AWNINGS ON CLARK

1/8" = 1'0"



#47 Clark & Grand
Permit Renewal

04.10.2014
Page 1





City of Chicago



O2014-4605

Office of the City Clerk Document Tracking Sheet

| | |
|---------------------------------|--|
| Meeting Date: | 5/28/2014 |
| Sponsor(s): | Reilly (42) |
| Type: | Ordinance |
| Title: | Awning(s) for North Community Bank |
| Committee(s) Assignment: | Committee on Transportation and Public Way |

ORDINANCE
NORTH COMMUNITY BANK
Acct. No. 87701 - 10
Permit No. 1112983

Be It Ordained by the City Council of the City of Chicago:

SECTION 1. Permission and authority are hereby given and granted to NORTH COMMUNITY BANK, upon the terms and subject to the conditions of this ordinance to maintain and use, as now constructed, seven (7) Awning(s) projecting over the public right-of-way adjacent to its premises known as 2 W. Elm St..

Said Awning(s) at W. Elm Street measure(s):

One (1) at seventy-three point five eight (73.58) feet in length, and five (5) feet in width for a total of three hundred sixty-seven point nine (367.9) square feet.

Said Awning(s) at ELM ST measure(s):

One (1) at seventy-three point five eight (73.58) feet in length, and five (5) feet in width for a total of three hundred sixty-seven point nine (367.9) square feet.

Said Awning(s) at ELM ST measure(s):

One (1) at seventy-three point five eight (73.58) feet in length, and five (5) feet in width for a total of three hundred sixty-seven point nine (367.9) square feet.

Said Awning(s) at ELM ST measure(s):

One (1) at seventy-three point five eight (73.58) feet in length, and five (5) feet in width for a total of three hundred sixty-seven point nine (367.9) square feet.

Said Awning(s) at STATE ST measure(s):

One (1) at twenty-seven (27) feet in length, and five (5) feet in width for a total of one hundred thirty-five (135) square feet.

Said Awning(s) at STATE ST measure(s):

One (1) at twenty-seven (27) feet in length, and five (5) feet in width for a total of one hundred thirty-five (135) square feet.

Said Awning(s) at STATE ST measure(s):

One (1) at twenty-seven (27) feet in length, and five (5) feet in width for a total of one hundred thirty-five (135) square feet.

The location of said privilege shall be as shown on prints kept on file with the Department of Business Affairs and Consumer Protection and the Office of the City Clerk.

Said privilege shall be constructed in accordance with plans and specifications approved by the Zoning Department - Signs.

This grant of privilege in the public way shall be subject to the provisions of Section 10-28-015 and all other required provisions of the Municipal Code of Chicago.

The grantee shall pay to the City of Chicago as compensation for the privilege #1112983 herein granted the sum of one hundred seventy-five (\$175.00) per annum in advance.

A 25% penalty will be added for payments received after due date.

The permit holder agrees to hold the City of Chicago harmless for any damage, relocation or replacement costs associated with damage, relocation or removal of private property caused by the City performing work in the public way.

Authority herein given and granted for a period of five (5) years from and after 03/18/2014.

Alderman _____

Brendan Reilly 42nd Ward

STATE ST

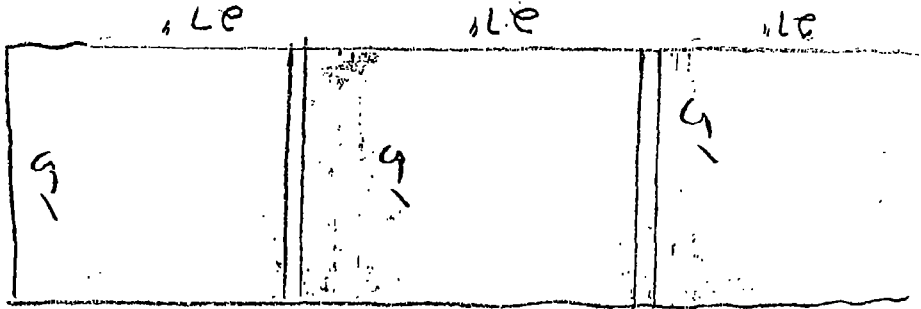

STATE ST



City of Chicago



O2014-4611

Office of the City Clerk

Document Tracking Sheet

| | |
|---------------------------------|--|
| Meeting Date: | 5/28/2014 |
| Sponsor(s): | Reilly (42) |
| Type: | Ordinance |
| Title: | Awning(s) for Rossi's Liquors, Inc. |
| Committee(s) Assignment: | Committee on Transportation and Public Way |

ORDINANCE
ROSSI'S LIQUORS INC
Acct. No. 11710 - 1
Permit No. 1112833

Be It Ordained by the City Council of the City of Chicago:

SECTION 1. Permission and authority are hereby given and granted to ROSSI'S LIQUORS INC, upon the terms and subject to the conditions of this ordinance to maintain and use, as now constructed, one (1) Awning(s) projecting over the public right-of-way adjacent to its premises known as 412 N. State St..

Said Awning(s) at N STATE ST measure(s):

One (1) at nineteen (19) feet in length, and two point two (2.2) feet in width for a total of forty-one point eight (41.8) square feet.

The location of said privilege shall be as shown on prints kept on file with the Department of Business Affairs and Consumer Protection and the Office of the City Clerk.

Said privilege shall be constructed in accordance with plans and specifications approved by the Zoning Department - Signs.

This grant of privilege in the public way shall be subject to the provisions of Section 10-28-015 and all other required provisions of the Municipal Code of Chicago.

The grantee shall pay to the City of Chicago as compensation for the privilege #1112833 herein granted the sum of fifty (\$50.00) per annum in advance.

A 25% penalty will be added for payments received after due date.

The permit holder agrees to hold the City of Chicago harmless for any damage, relocation or replacement costs associated with damage, relocation or removal of private property caused by the City performing work in the public way.

Authority herein given and granted for a period of five (5) years from and after 04/22/2014.

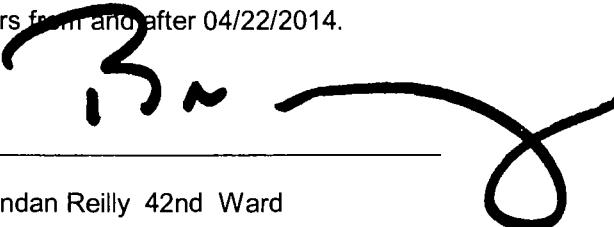
Alderman  _____
Brendan Reilly 42nd Ward

Handwritten signature or scribble.



APPLICATION TO USE THE PUBLIC RIGHT OF WAY

EXAMPLE OF CANOPY/AWNING DRAWING

CANOPY DRAWINGS

PROPERTY LOCATION: 412 N. STATE ST.
ORGANIZATION'S NAME: ROSSI'S

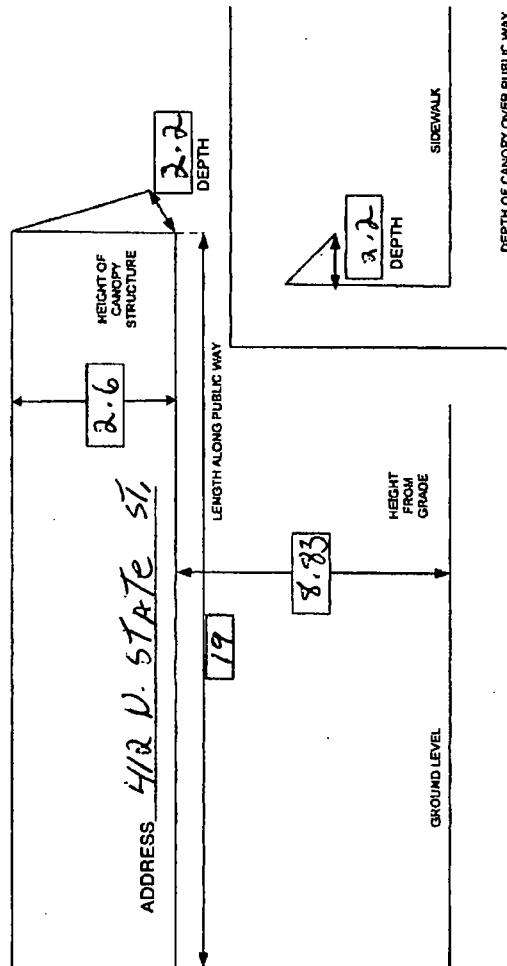



City of Chicago



O2014-4613

Office of the City Clerk

Document Tracking Sheet

| | |
|---------------------------------|--|
| Meeting Date: | 5/28/2014 |
| Sponsor(s): | Smith (43) |
| Type: | Ordinance |
| Title: | Awning(s) for Trattoria Gianni |
| Committee(s) Assignment: | Committee on Transportation and Public Way |

ORDINANCE
TRATTORIA GIANNI
Acct. No. 6577 - 1
Permit No. 1112937

Be It Ordained by the City Council of the City of Chicago:

SECTION 1. Permission and authority are hereby given and granted to TRATTORIA GIANNI, upon the terms and subject to the conditions of this ordinance to maintain and use, as now constructed, one (1) Awning(s) projecting over the public right-of-way adjacent to its premises known as 1711 N. Halsted St..

Said Awning(s) at N.HALSTED measure(s):

One (1) at twenty-five (25) feet in length, and four point five (4.5) feet in width for a total of one hundred twelve point five (112.5) square feet.

The location of said privilege shall be as shown on prints kept on file with the Department of Business Affairs and Consumer Protection and the Office of the City Clerk.

Said privilege shall be constructed in accordance with plans and specifications approved by the Zoning Department - Signs.

This grant of privilege in the public way shall be subject to the provisions of Section 10-28-015 and all other required provisions of the Municipal Code of Chicago.

The grantee shall pay to the City of Chicago as compensation for the privilege #1112937 herein granted the sum of fifty (\$50.00) per annum in advance.

A 25% penalty will be added for payments received after due date.

The permit holder agrees to hold the City of Chicago harmless for any damage, relocation or replacement costs associated with damage, relocation or removal of private property caused by the City performing work in the public way.

Authority herein given and granted for a period of five (5) years from and after 05/24/2014.

Alderman _____

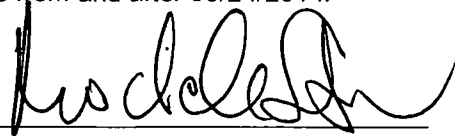

Michele Smith 43rd Ward

1711 N HALSTED ST

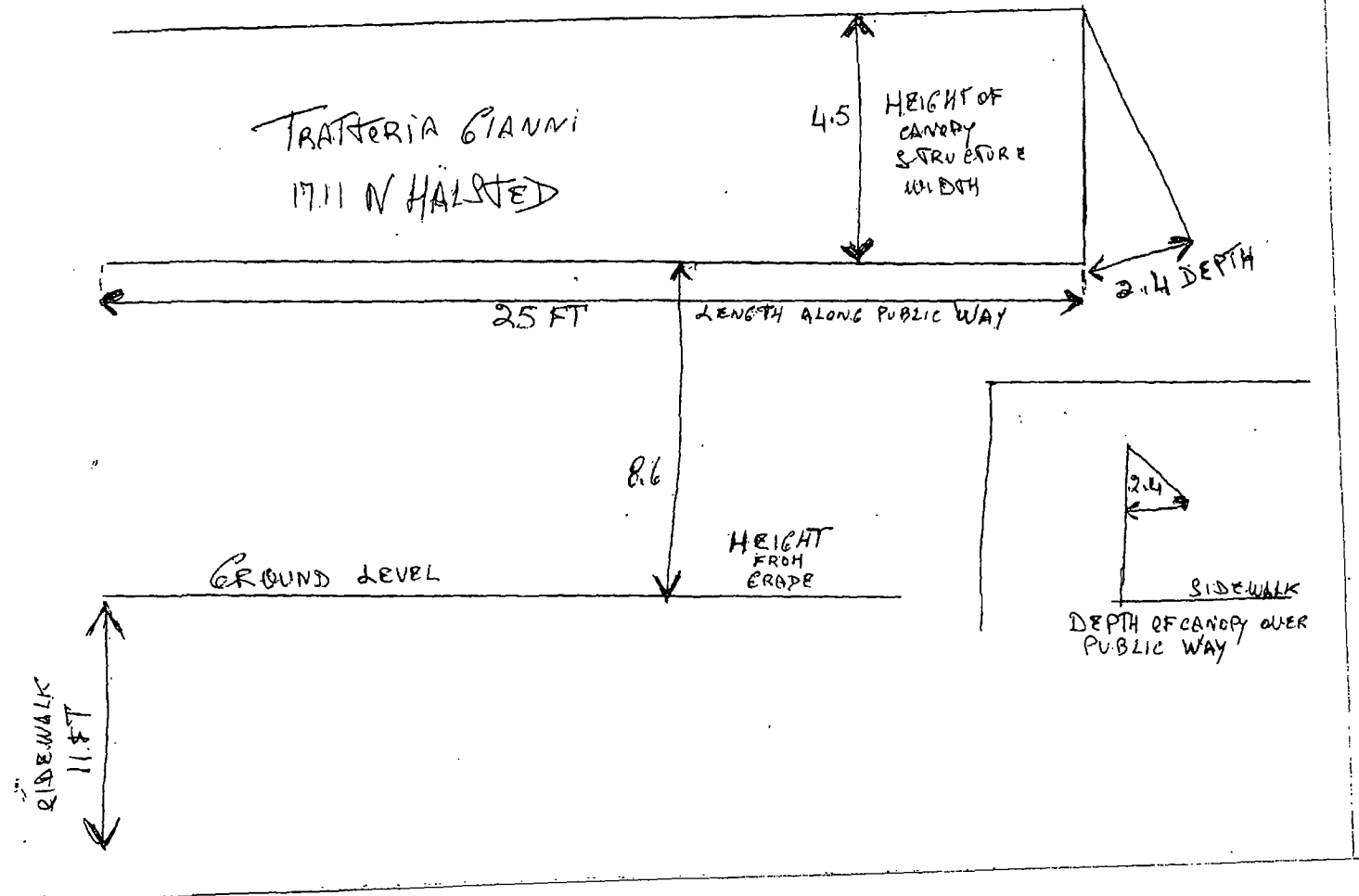



City of Chicago



O2014-4619

Office of the City Clerk

Document Tracking Sheet

| | |
|---------------------------------|--|
| Meeting Date: | 5/28/2014 |
| Sponsor(s): | Tunney (44) |
| Type: | Ordinance |
| Title: | Awning(s) for Artemio's Bakery |
| Committee(s) Assignment: | Committee on Transportation and Public Way |

ORDINANCE
ARTEMIO'S BAKERY
Acct. No. 6600 - 2
Permit No. 1112955

Be It Ordained by the City Council of the City of Chicago:

SECTION 1. Permission and authority are hereby given and granted to ARTEMIO'S BAKERY, upon the terms and subject to the conditions of this ordinance to maintain and use, as now constructed, two (2) Awning(s) projecting over the public right-of-way adjacent to its premises known as 3919 N. Sheridan Rd..

Said Awning(s) at N. SHERIDAN measure(s):

One (1) at sixteen (16) feet in length, and five point one seven (5.17) feet in width for a total of eighty-two point seven two (82.72) square feet.

Said Awning(s) at N. SHERIDAN measure(s):

One (1) at fifteen point four two (15.42) feet in length, and five point one seven (5.17) feet in width for a total of seventy-nine point seven two (79.72) square feet.

The location of said privilege shall be as shown on prints kept on file with the Department of Business Affairs and Consumer Protection and the Office of the City Clerk.

Said privilege shall be constructed in accordance with plans and specifications approved by the Zoning Department - Signs.

This grant of privilege in the public way shall be subject to the provisions of Section 10-28-015 and all other required provisions of the Municipal Code of Chicago.

The grantee shall pay to the City of Chicago as compensation for the privilege #1112955 herein granted the sum of one hundred (\$100.00) per annum in advance.

A 25% penalty will be added for payments received after due date.

The permit holder agrees to hold the City of Chicago harmless for any damage, relocation or replacement costs associated with damage, relocation or removal of private property caused by the City performing work in the public way.

Authority herein given and granted for a period of five (5) years from and after 05/13/2014.

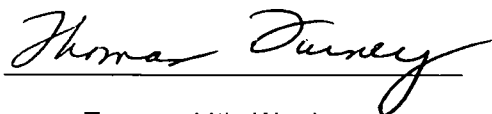
Alderman 
Thomas Tunney 44th Ward

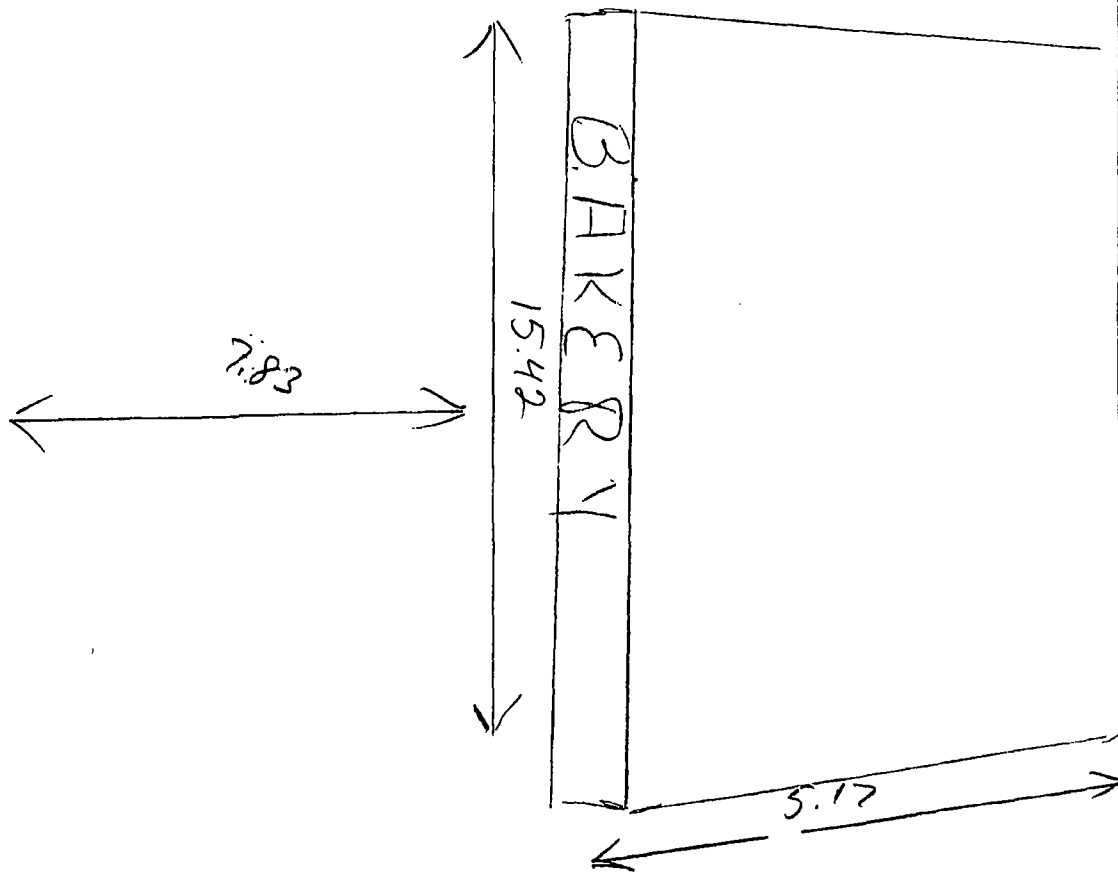
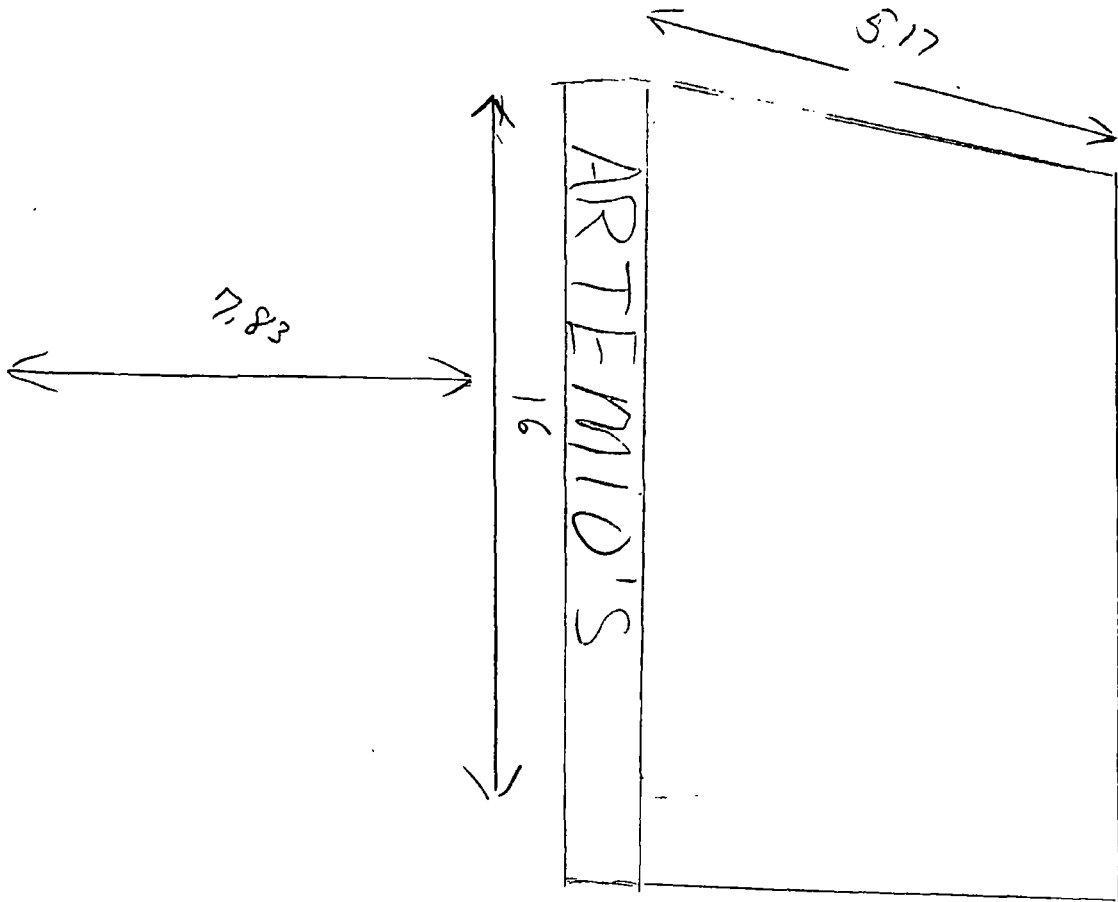



City of Chicago



O2014-4630

Office of the City Clerk

Document Tracking Sheet

| | |
|---------------------------------|--|
| Meeting Date: | 5/28/2014 |
| Sponsor(s): | Tunney (44) |
| Type: | Ordinance |
| Title: | Awning(s) for Ballet D'Enfant |
| Committee(s) Assignment: | Committee on Transportation and Public Way |

ORDINANCE
BALLET D'ENFANT
Acct. No. 219931 - 1
Permit No. 1113047

Be It Ordained by the City Council of the City of Chicago:

SECTION 1. Permission and authority are hereby given and granted to BALLET D'ENFANT, upon the terms and subject to the conditions of this ordinance to maintain and use, as now constructed, three (3) Awning(s) projecting over the public right-of-way adjacent to its premises known as 3234 N. Southport Ave..

Said Awning(s) at N SOUTHPORT AVE measure(s):

One (1) at fourteen point seven five (14.75) feet in length, and three point four two (3.42) feet in width for a total of fifty point four five (50.45) square feet.

Said Awning(s) at W MELROSE measure(s):

One (1) at seven point one seven (7.17) feet in length, and three point four two (3.42) feet in width for a total of twenty-four point five two (24.52) square feet.

Said Awning(s) at N SOUTHPORT AVE measure(s):

One (1) at eight point eight three (8.83) feet in length, and three point four two (3.42) feet in width for a total of thirty point two (30.2) square feet.

The location of said privilege shall be as shown on prints kept on file with the Department of Business Affairs and Consumer Protection and the Office of the City Clerk.

Said privilege shall be constructed in accordance with plans and specifications approved by the Zoning Department - Signs.

This grant of privilege in the public way shall be subject to the provisions of Section 10-28-015 and all other required provisions of the Municipal Code of Chicago.

The grantee shall pay to the City of Chicago as compensation for the privilege #1113047 herein granted the sum of one hundred fifty (\$150.00) per annum in advance.

A 25% penalty will be added for payments received after due date.

The permit holder agrees to hold the City of Chicago harmless for any damage, relocation or replacement costs associated with damage, relocation or removal of private property caused by the City performing work in the public way.

Authority herein given and granted for a period of five (5) years from and after 04/22/2014.

Alderman 
Thomas Tunney 44th Ward

3234 N. Southport Ave.

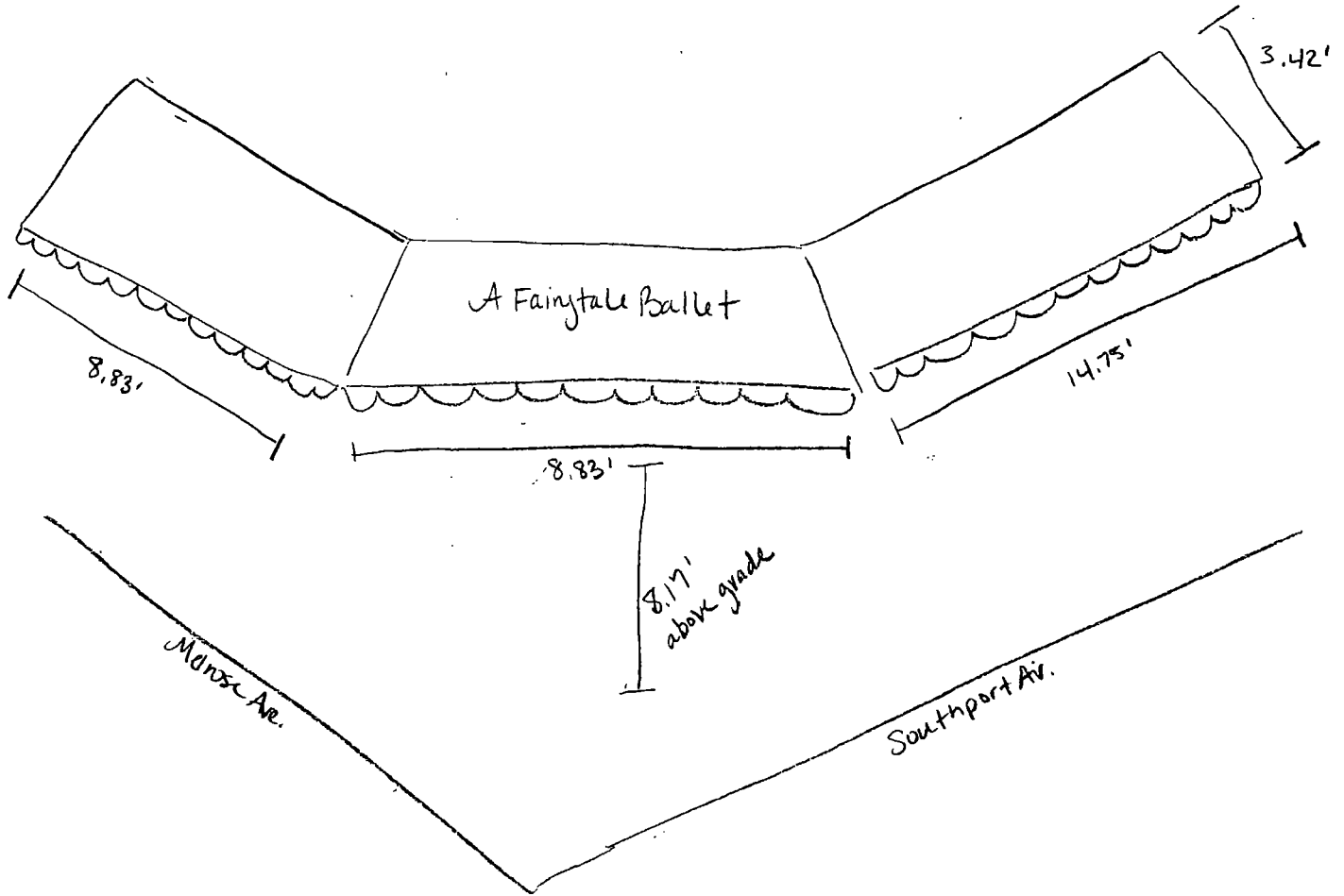



City of Chicago

Office of the City Clerk

Document Tracking Sheet



O2014-4636

| | |
|---------------------------------|--|
| Meeting Date: | 5/28/2014 |
| Sponsor(s): | Tunney (44) |
| Type: | Ordinance |
| Title: | Awning(s) for Carissima, Inc. |
| Committee(s) Assignment: | Committee on Transportation and Public Way |

ORDINANCE
CARISSIMA INC
Acct. No. 28028 - 1
Permit No. 1113098

Be It Ordained by the City Council of the City of Chicago:

SECTION 1. Permission and authority are hereby given and granted to CARISSIMA INC, upon the terms and subject to the conditions of this ordinance to maintain and use, as now constructed, three (3) Awning(s) projecting over the public right-of-way adjacent to its premises known as 2901-03 N. Clark St..

Said Awning(s) at N. Clark St. measure(s):

One (1) at twenty-one point seven (21.7) feet in length, and two (2) feet in width for a total of forty-three point four (43.4) square feet.

Said Awning(s) at N. Clark St. measure(s):

One (1) at seventeen (17) feet in length, and two (2) feet in width for a total of thirty-four (34) square feet.

Said Awning(s) at W. Surf measure(s):

One (1) at sixteen point one one (16.11) feet in length, and two (2) feet in width for a total of thirty-two point two two (32.22) square feet.

The location of said privilege shall be as shown on prints kept on file with the Department of Business Affairs and Consumer Protection and the Office of the City Clerk.

Said privilege shall be constructed in accordance with plans and specifications approved by the Zoning Department - Signs.

This grant of privilege in the public way shall be subject to the provisions of Section 10-28-015 and all other required provisions of the Municipal Code of Chicago.

The grantee shall pay to the City of Chicago as compensation for the privilege #1113098 herein granted the sum of one hundred fifty (\$150.00) per annum in advance.

A 25% penalty will be added for payments received after due date.

The permit holder agrees to hold the City of Chicago harmless for any damage, relocation or replacement costs associated with damage, relocation or removal of private property caused by the City performing work in the public way.

Authority herein given and granted for a period of five (5) years from and after 04/26/2014.

Alderman 
Thomas Tunney 44th Ward

MARIO'S DESIGN
AWNING / NEON / SIGN
773-818-SIGN
FAX#-773-486-5152

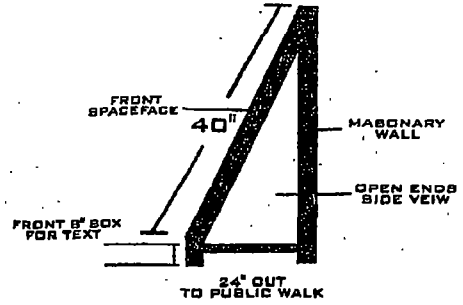

FRONT VIEW CLARK ST.



FRONT VIEW CLARK ST.



SIDE STREET VIEW

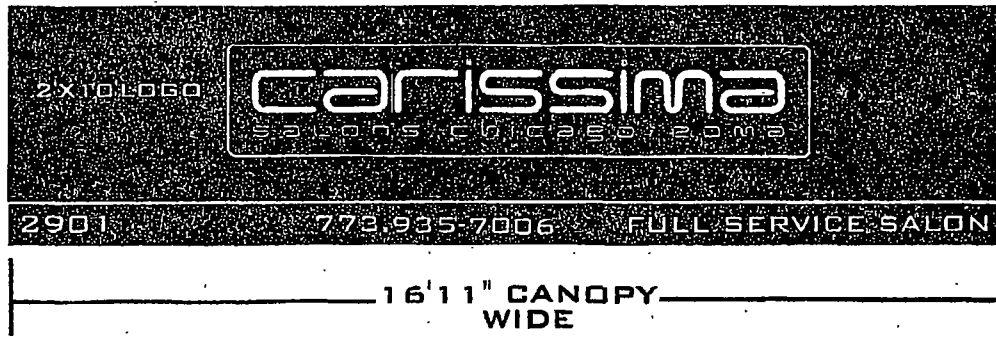



City of Chicago



O2014-4638

Office of the City Clerk

Document Tracking Sheet

| | |
|---------------------------------|--|
| Meeting Date: | 5/28/2014 |
| Sponsor(s): | Tunney (44) |
| Type: | Ordinance |
| Title: | Awning(s) for Cohiba Cuban Cuisine, Inc. |
| Committee(s) Assignment: | Committee on Transportation and Public Way |

ORDINANCE
COHIBA CUBAN CUISINE, INC.
Acct. No. 388526 - 1
Permit No. 1111681

Be It Ordained by the City Council of the City of Chicago:

SECTION 1. Permission and authority are hereby given and granted to COHIBA CUBAN CUISINE, INC., upon the terms and subject to the conditions of this ordinance to construct, install, maintain and use one (1) Awning(s) projecting over the public right-of-way adjacent to its premises known as 2835 N. Broadway .

Said Awning(s) at N. Broadway measure(s):

One (1) at twenty-five (25) feet in length, and two (2) feet in width for a total of fifty (50) square feet.

The location of said privilege shall be as shown on prints kept on file with the Department of Business Affairs and Consumer Protection and the Office of the City Clerk.

Said privilege shall be constructed in accordance with plans and specifications approved by the Zoning Department - Signs.

This grant of privilege in the public way shall be subject to the provisions of Section 10-28-015 and all other required provisions of the Municipal Code of Chicago.

The grantee shall pay to the City of Chicago as compensation for the privilege #1111681 herein granted the sum of fifty (\$50.00) per annum in advance.

A 25% penalty will be added for payments received after due date.

The permit holder agrees to hold the City of Chicago harmless for any damage, relocation or replacement costs associated with damage, relocation or removal of private property caused by the City performing work in the public way.

Authority herein given and granted for a period of five (5) years from and after Date of Passage.

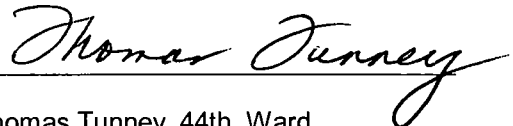
Alderman 
Thomas Tunney 44th Ward

AWNING

CROSS SECTION DETAIL

Installation Detail

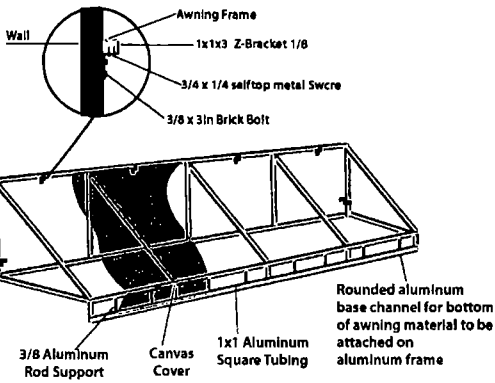

- ALUMINUM FRAMED AWNING
- 15 oz CANVAS FABRIC IN COLOR TAN
- PAINTED LOGO IN BROWN, GREEN & ORANGE
- WALL MOUNTED
- READS: Cohiba Cuban Cuisine, 2835 N. Broadway, 847.636.1062
cohibacubancuisine.com

NOTE: Photo for representational purposes only. Signs are not to scale and may appear larger or smaller than shown

| Sign Erector: | Applicant: | Location: |
|--|---|---|
| PRO IMAGE 2008 W. Chicago, Ave. Chicago, IL 60622 Tel. 773 292 1111 Fax. 773 292 1113 | Cohiba Cuban Cuisine 2835 N. Broadway Chicago, IL 60657 Tel: 847.636.1062 | Front Elevation Date: 03-5-2014 |



City of Chicago



O2014-4645

Office of the City Clerk Document Tracking Sheet

| | |
|---------------------------------|--|
| Meeting Date: | 5/28/2014 |
| Sponsor(s): | Tunney (44) |
| Type: | Ordinance |
| Title: | Awning(s) for Exedus II |
| Committee(s) Assignment: | Committee on Transportation and Public Way |

ORDINANCE
EXEDUS II
Acct. No. 28217 - 1
Permit No. 1112814

Be It Ordained by the City Council of the City of Chicago:

SECTION 1. Permission and authority are hereby given and granted to EXEDUS II, upon the terms and subject to the conditions of this ordinance to maintain and use, as now constructed, one (1) Awning(s) projecting over the public right-of-way adjacent to its premises known as 3477 N. Clark St..

Said Awning(s) at N. CLARK ST measure(s):

One (1) at twenty-four point zero eight (24.08) feet in length, and four point zero eight (4.08) feet in width for a total of ninety-eight point two five (98.25) square feet.

The location of said privilege shall be as shown on prints kept on file with the Department of Business Affairs and Consumer Protection and the Office of the City Clerk.

Said privilege shall be constructed in accordance with plans and specifications approved by the Zoning Department - Signs.

This grant of privilege in the public way shall be subject to the provisions of Section 10-28-015 and all other required provisions of the Municipal Code of Chicago.

The grantee shall pay to the City of Chicago as compensation for the privilege #1112814 herein granted the sum of fifty (\$50.00) per annum in advance.

A 25% penalty will be added for payments received after due date.

The permit holder agrees to hold the City of Chicago harmless for any damage, relocation or replacement costs associated with damage, relocation or removal of private property caused by the City performing work in the public way.

Authority herein given and granted for a period of five (5) years from and after 04/22/2014.

Alderman Thomas Tunney
Thomas Tunney 44th Ward

3477 N CLARK ST

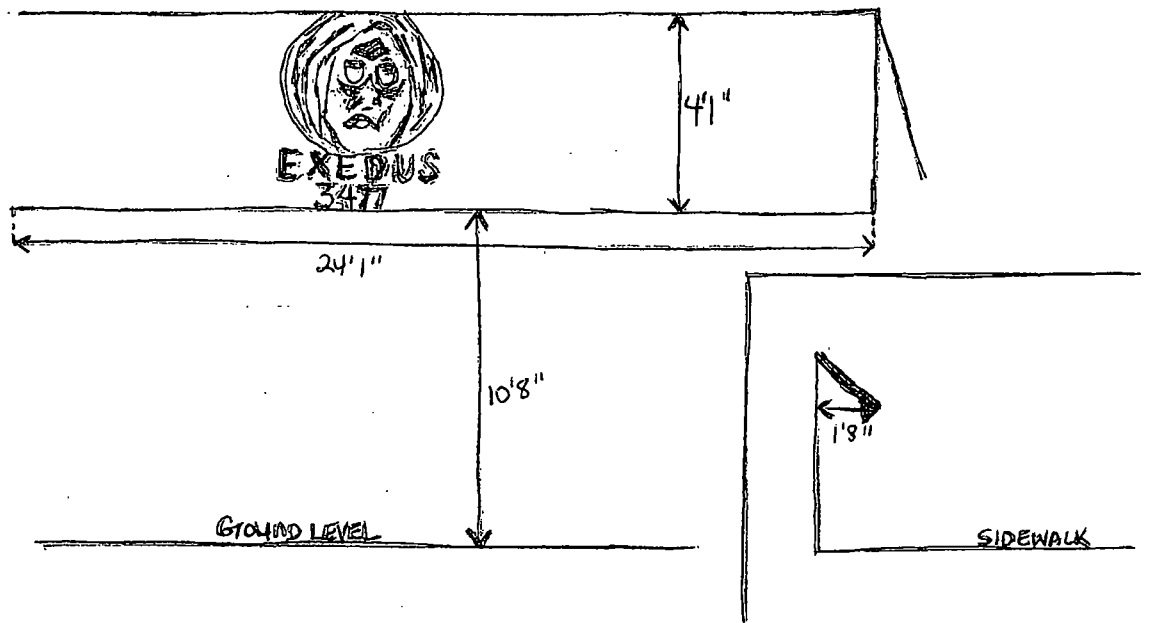



City of Chicago



O2014-4647

Office of the City Clerk

Document Tracking Sheet

| | |
|---------------------------------|--|
| Meeting Date: | 5/28/2014 |
| Sponsor(s): | Tunney (44) |
| Type: | Ordinance |
| Title: | Awning(s) for K.S. Cleaners and Laundromat |
| Committee(s) Assignment: | Committee on Transportation and Public Way |

ORDINANCE
K.S. CLAENERS AND LAUNDROMAT
Acct. No. 216184 - 1
Permit No. 1112873

Be It Ordained by the City Council of the City of Chicago:

SECTION 1. Permission and authority are hereby given and granted to K.S. CLAENERS AND LAUNDROMAT, upon the terms and subject to the conditions of this ordinance to maintain and use, as now constructed, one (1) Awning(s) projecting over the public right-of-way adjacent to its premises known as 3904 N. Sheridan Rd..

Said Awning(s) at N Sheridan Rd measure(s):

One (1) at thirty-three (33) feet in length, and two point six seven (2.67) feet in width for a total of eighty-eight point one one (88.11) square feet.

The location of said privilege shall be as shown on prints kept on file with the Department of Business Affairs and Consumer Protection and the Office of the City Clerk.

Said privilege shall be constructed in accordance with plans and specifications approved by the Zoning Department - Signs.

This grant of privilege in the public way shall be subject to the provisions of Section 10-28-015 and all other required provisions of the Municipal Code of Chicago.

The grantee shall pay to the City of Chicago as compensation for the privilege #1112873 herein granted the sum of fifty-eight (\$58.00) per annum in advance.

A 25% penalty will be added for payments received after due date.

The permit holder agrees to hold the City of Chicago harmless for any damage, relocation or replacement costs associated with damage, relocation or removal of private property caused by the City performing work in the public way.

Authority herein given and granted for a period of five (5) years from and after 03/18/2014.

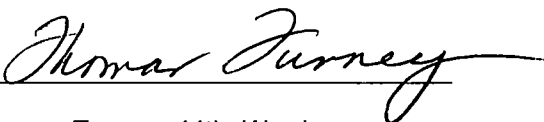
Alderman 
Thomas Tunney 44th Ward

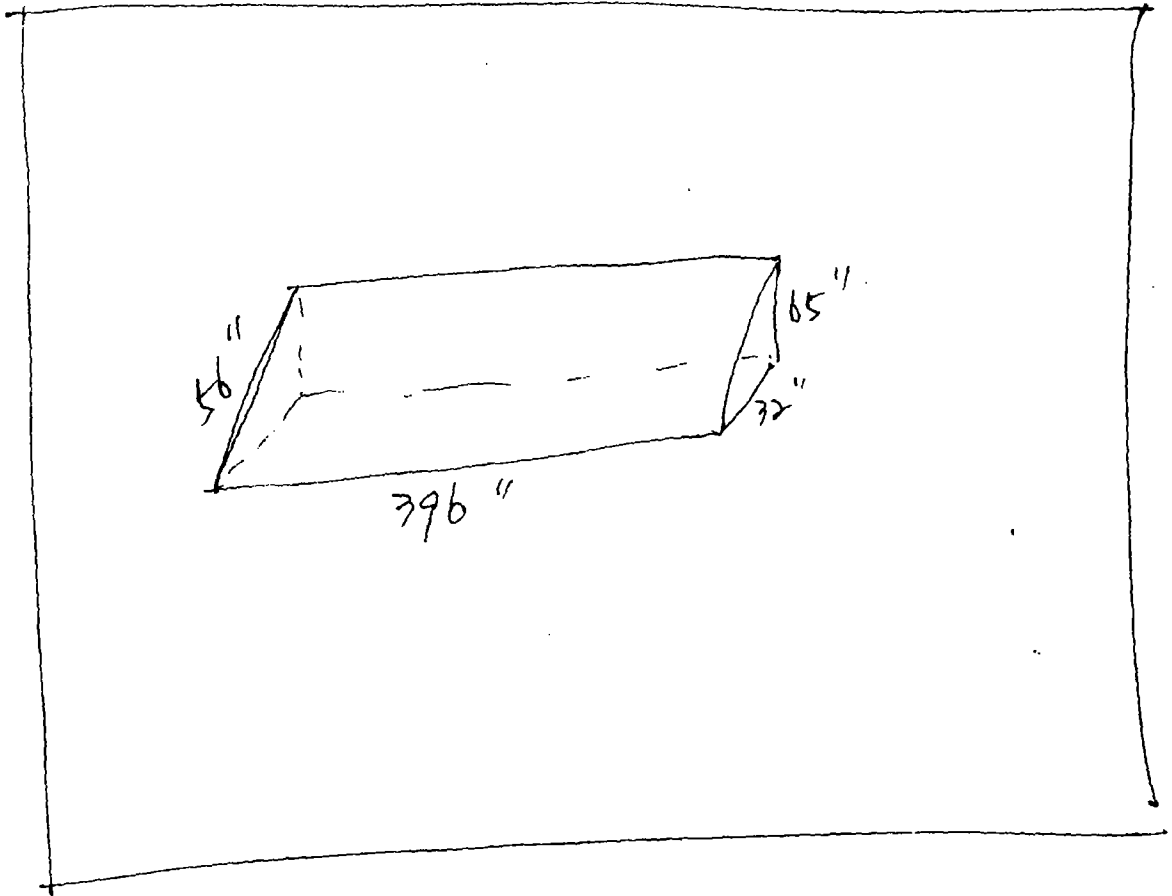



City of Chicago



O2014-4648

Office of the City Clerk
Document Tracking Sheet

| | |
|---------------------------------|--|
| Meeting Date: | 5/28/2014 |
| Sponsor(s): | Tunney (44) |
| Type: | Ordinance |
| Title: | Awning(s) for McKillip Animal Hospitals |
| Committee(s) Assignment: | Committee on Transportation and Public Way |

ORDINANCE
McKillip Animal Hospitals
Acct. No. 24307 - 1
Permit No. 1112958

Be It Ordained by the City Council of the City of Chicago:

SECTION 1. Permission and authority are hereby given and granted to McKillip Animal Hospitals, upon the terms and subject to the conditions of this ordinance to maintain and use, as now constructed, one (1) Awning(s) projecting over the public right-of-way adjacent to its premises known as 2867 N. Clark St..

Said Awning(s) at N. Clark St. measure(s):

One (1) at twenty-one (21) feet in length, and two (2) feet in width for a total of forty-two (42) square feet.

The location of said privilege shall be as shown on prints kept on file with the Department of Business Affairs and Consumer Protection and the Office of the City Clerk.

Said privilege shall be constructed in accordance with plans and specifications approved by the Zoning Department - Signs.

This grant of privilege in the public way shall be subject to the provisions of Section 10-28-015 and all other required provisions of the Municipal Code of Chicago.

The grantee shall pay to the City of Chicago as compensation for the privilege #1112958 herein granted the sum of fifty (\$50.00) per annum in advance.

A 25% penalty will be added for payments received after due date.

The permit holder agrees to hold the City of Chicago harmless for any damage, relocation or replacement costs associated with damage, relocation or removal of private property caused by the City performing work in the public way.

Authority herein given and granted for a period of five (5) years from and after 04/26/2014.

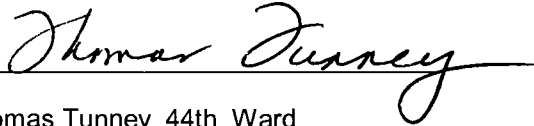
Alderman 
Thomas Tunney 44th Ward

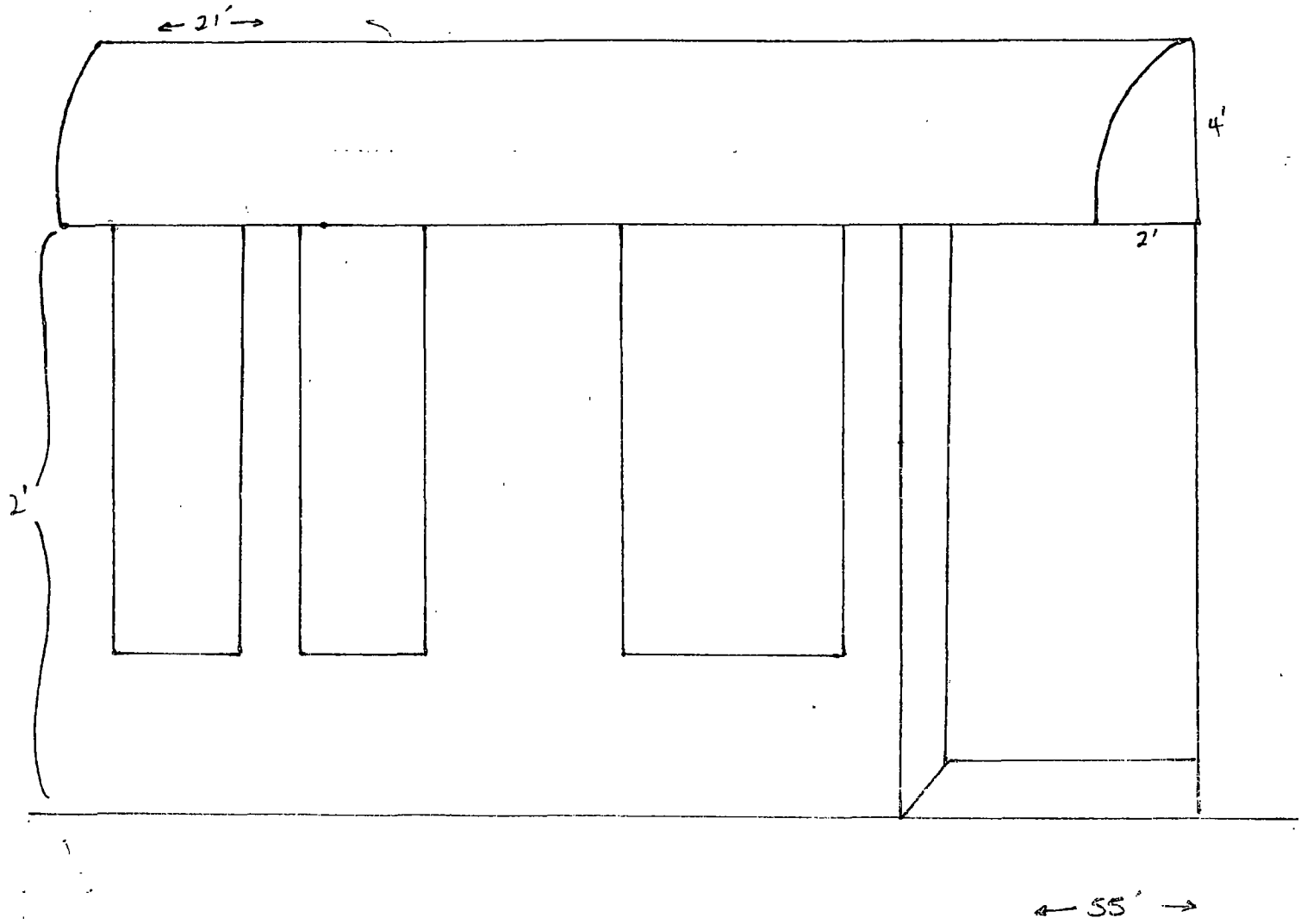



City of Chicago



O2014-4650

Office of the City Clerk

Document Tracking Sheet

| | |
|---------------------------------|--|
| Meeting Date: | 5/28/2014 |
| Sponsor(s): | Tunney (44) |
| Type: | Ordinance |
| Title: | Awning(s) for Murphy's Bleachers |
| Committee(s) Assignment: | Committee on Transportation and Public Way |

ORDINANCE
Murphy's Bleachers
Acct. No. 13 - 2
Permit No. 1113094

Be It Ordained by the City Council of the City of Chicago:

SECTION 1. Permission and authority are hereby given and granted to Murphy's Bleachers, upon the terms and subject to the conditions of this ordinance to maintain and use, as now constructed, one (1) Awning(s) projecting over the public right-of-way adjacent to its premises known as 3655 N. Sheffield Ave..

Said Awning(s) at N. Sheffield Ave. measure(s):

One (1) at twenty-five (25) feet in length, and four (4) feet in width for a total of one hundred (100) square feet.

The location of said privilege shall be as shown on prints kept on file with the Department of Business Affairs and Consumer Protection and the Office of the City Clerk.

Said privilege shall be constructed in accordance with plans and specifications approved by the Zoning Department - Signs.

This grant of privilege in the public way shall be subject to the provisions of Section 10-28-015 and all other required provisions of the Municipal Code of Chicago.

The grantee shall pay to the City of Chicago as compensation for the privilege #1113094 herein granted the sum of fifty (\$50.00) per annum in advance.

A 25% penalty will be added for payments received after due date.

The permit holder agrees to hold the City of Chicago harmless for any damage, relocation or replacement costs associated with damage, relocation or removal of private property caused by the City performing work in the public way.

Authority herein given and granted for a period of five (5) years from and after 04/26/2014.

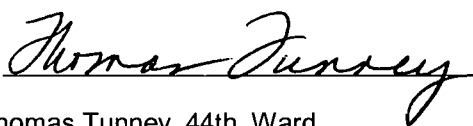
Alderman 
Thomas Tunney 44th Ward



Front Elevation

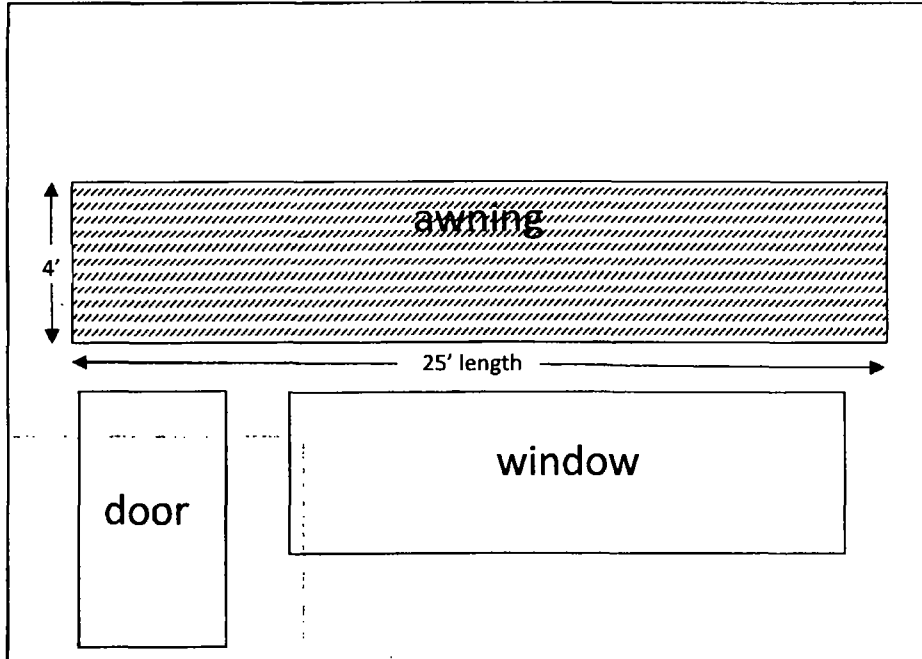

Side Elevation

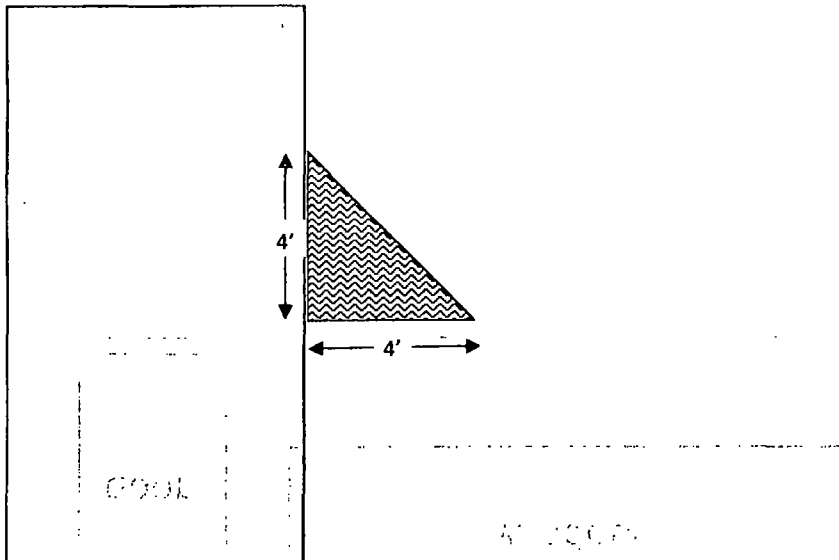



City of Chicago



O2014-4651

Office of the City Clerk

Document Tracking Sheet

| | |
|---------------------------------|--|
| Meeting Date: | 5/28/2014 |
| Sponsor(s): | Tunney (44) |
| Type: | Ordinance |
| Title: | Awning(s) for New Cleaners |
| Committee(s) Assignment: | Committee on Transportation and Public Way |

ORDINANCE
NEW CLEANERS
Acct. No. 62082 - 1
Permit No. 1112438

Be It Ordained by the City Council of the City of Chicago:

SECTION 1. Permission and authority are hereby given and granted to NEW CLEANERS, upon the terms and subject to the conditions of this ordinance to maintain and use, as now constructed, one (1) Awning(s) projecting over the public right-of-way adjacent to its premises known as 3232 N. Broadway .

Said Awning(s) at N. Broadway measure(s):

One (1) at forty-eight (48) feet in length, and four point five (4.5) feet in width for a total of two hundred sixteen (216) square feet.

The location of said privilege shall be as shown on prints kept on file with the Department of Business Affairs and Consumer Protection and the Office of the City Clerk.

Said privilege shall be constructed in accordance with plans and specifications approved by the Zoning Department - Signs.

This grant of privilege in the public way shall be subject to the provisions of Section 10-28-015 and all other required provisions of the Municipal Code of Chicago.

The grantee shall pay to the City of Chicago as compensation for the privilege #1112438 herein granted the sum of seventy-three (\$73.00) per annum in advance.

A 25% penalty will be added for payments received after due date.

The permit holder agrees to hold the City of Chicago harmless for any damage, relocation or replacement costs associated with damage, relocation or removal of private property caused by the City performing work in the public way.

Authority herein given and granted for a period of five (5) years from and after 03/18/2014.

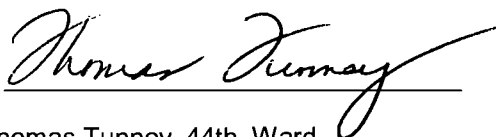
Alderman 
Thomas Tunney 44th Ward

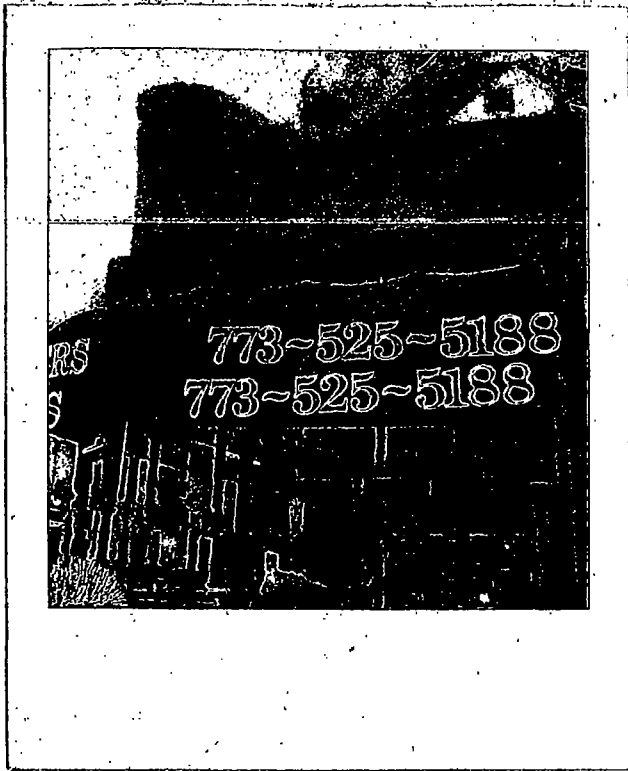



City of Chicago



O2014-4654

Office of the City Clerk

Document Tracking Sheet

| | |
|---------------------------------|--|
| Meeting Date: | 5/28/2014 |
| Sponsor(s): | Tunney (44) |
| Type: | Ordinance |
| Title: | Awning(s) for Plus Auto Care |
| Committee(s) Assignment: | Committee on Transportation and Public Way |

ORDINANCE
PLUS AUTO CARE
Acct. No. 35917 - 1
Permit No. 1112984

Be It Ordained by the City Council of the City of Chicago:

SECTION 1. Permission and authority are hereby given and granted to PLUS AUTO CARE, upon the terms and subject to the conditions of this ordinance to maintain and use, as now constructed, one (1) Awning(s) projecting over the public right-of-way adjacent to its premises known as 3448 N. Southport Ave..

Said Awning(s) at N. SOUTHPORT measure(s):

One (1) at twenty-one (21) feet in length, and five (5) feet in width for a total of one hundred five (105) square feet.

The location of said privilege shall be as shown on prints kept on file with the Department of Business Affairs and Consumer Protection and the Office of the City Clerk.

Said privilege shall be constructed in accordance with plans and specifications approved by the Zoning Department - Signs.

This grant of privilege in the public way shall be subject to the provisions of Section 10-28-015 and all other required provisions of the Municipal Code of Chicago.

The grantee shall pay to the City of Chicago as compensation for the privilege #1112984 herein granted the sum of fifty (\$50.00) per annum in advance.

A 25% penalty will be added for payments received after due date.

The permit holder agrees to hold the City of Chicago harmless for any damage, relocation or replacement costs associated with damage, relocation or removal of private property caused by the City performing work in the public way.

Authority herein given and granted for a period of five (5) years from and after 03/18/2014.

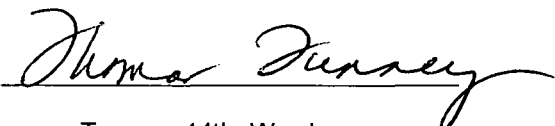
Alderman 
Thomas Tunney 44th Ward



Mail

Search Web

Hi, Mariëta

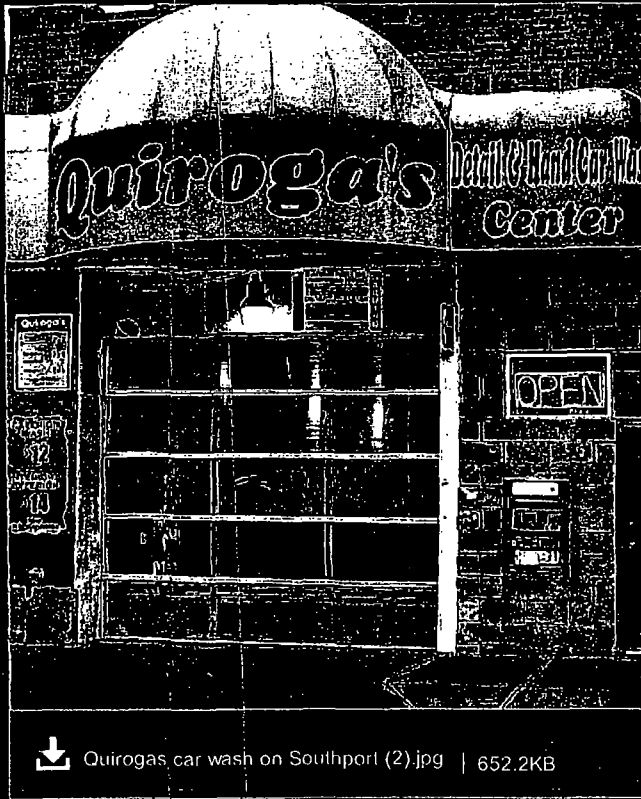

↓ Quirogas car wash on Southport (2).jpg | 652.2KB





City of Chicago



O2014-4659

Office of the City Clerk

Document Tracking Sheet

| | |
|---------------------------------|--|
| Meeting Date: | 5/28/2014 |
| Sponsor(s): | Tunney (44) |
| Type: | Ordinance |
| Title: | Awning(s) for Shirts Illustrated, Inc. |
| Committee(s) Assignment: | Committee on Transportation and Public Way |

ORDINANCE
SHIRTS ILLUSTRATED INC
Acct. No. 28594 - 2
Permit No. 1113065

Be It Ordained by the City Council of the City of Chicago:

SECTION 1. Permission and authority are hereby given and granted to SHIRTS ILLUSTRATED INC, upon the terms and subject to the conditions of this ordinance to maintain and use, as now constructed, one (1) Awning(s) projecting over the public right-of-way adjacent to its premises known as 1340 W. Belmont Ave..

Said Awning(s) at W Belmont Ave measure(s):

One (1) at thirteen point six seven (13.67) feet in length, and two (2) feet in width for a total of twenty-seven point three four (27.34) square feet.

The location of said privilege shall be as shown on prints kept on file with the Department of Business Affairs and Consumer Protection and the Office of the City Clerk.

Said privilege shall be constructed in accordance with plans and specifications approved by the Zoning Department - Signs.

This grant of privilege in the public way shall be subject to the provisions of Section 10-28-015 and all other required provisions of the Municipal Code of Chicago.

The grantee shall pay to the City of Chicago as compensation for the privilege #1113065 herein granted the sum of fifty (\$50.00) per annum in advance.

A 25% penalty will be added for payments received after due date.

The permit holder agrees to hold the City of Chicago harmless for any damage, relocation or replacement costs associated with damage, relocation or removal of private property caused by the City performing work in the public way.

Authority herein given and granted for a period of five (5) years from and after 01/13/2014.

Alderman Thomas Tunney
Thomas Tunney 44th Ward

N

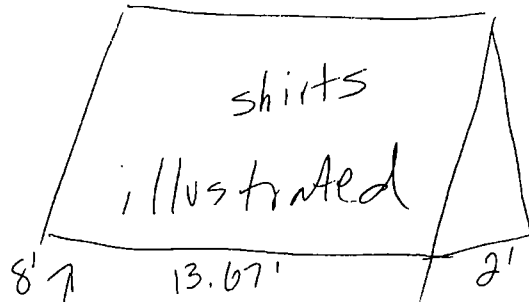

W

E

1340 W. Belmont Ave

S



City of Chicago



O2014-4661

Office of the City Clerk Document Tracking Sheet

| | |
|---------------------------------|--|
| Meeting Date: | 5/28/2014 |
| Sponsor(s): | Tunney (44) |
| Type: | Ordinance |
| Title: | Awning(s) for Sushi Mura Japanese Restaurant |
| Committee(s) Assignment: | Committee on Transportation and Public Way |

ORDINANCE
SUSHI MURA JAPANESE RESTAURANT
Acct. No. 17678 - 2
Permit No. 1113015

Be It Ordained by the City Council of the City of Chicago:

SECTION 1. Permission and authority are hereby given and granted to SUSHI MURA JAPANESE RESTAURANT, upon the terms and subject to the conditions of this ordinance to maintain and use, as now constructed, one (1) Awning(s) projecting over the public right-of-way adjacent to its premises known as 3647 N. Southport Ave..

Said Awning(s) at NORTH SOUTPORT AVE. measure(s):

One (1) at twenty-five (25) feet in length, and two point five (2.5) feet in width for a total of sixty-two point five (62.5) square feet.

The location of said privilege shall be as shown on prints kept on file with the Department of Business Affairs and Consumer Protection and the Office of the City Clerk.

Said privilege shall be constructed in accordance with plans and specifications approved by the Zoning Department - Signs.

This grant of privilege in the public way shall be subject to the provisions of Section 10-28-015 and all other required provisions of the Municipal Code of Chicago.

The grantee shall pay to the City of Chicago as compensation for the privilege #1113015 herein granted the sum of fifty (\$50.00) per annum in advance.

A 25% penalty will be added for payments received after due date.

The permit holder agrees to hold the City of Chicago harmless for any damage, relocation or replacement costs associated with damage, relocation or removal of private property caused by the City performing work in the public way.

Authority herein given and granted for a period of five (5) years from and after 04/26/2014.

Alderman 
Thomas Tunney 44th Ward

3647 N. Southport Ave

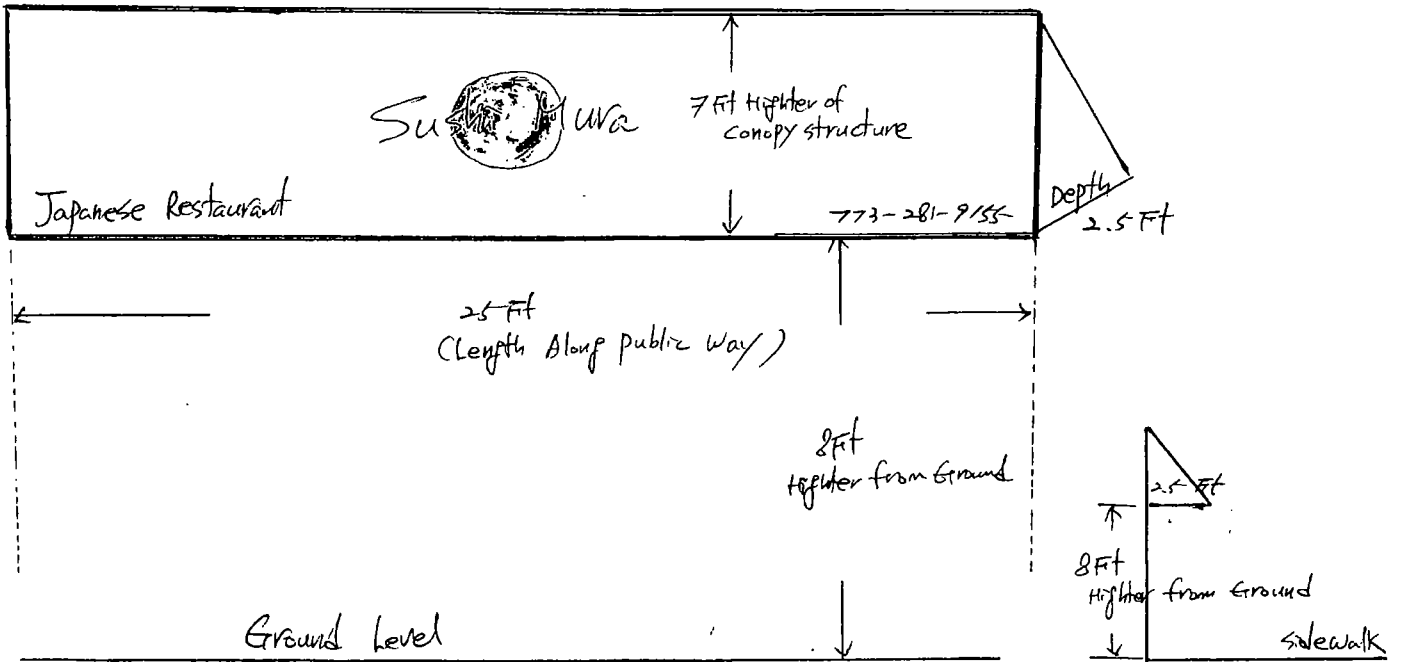



City of Chicago



O2014-4663

Office of the City Clerk Document Tracking Sheet

| | |
|---------------------------------|--|
| Meeting Date: | 5/28/2014 |
| Sponsor(s): | Tunney (44) |
| Type: | Ordinance |
| Title: | Awning(s) for 7-Eleven |
| Committee(s) Assignment: | Committee on Transportation and Public Way |

ORDINANCE
7-ELEVEN
Acct. No. 65465 - 47
Permit No. 1112823

Be It Ordained by the City Council of the City of Chicago:

SECTION 1. Permission and authority are hereby given and granted to 7-ELEVEN, upon the terms and subject to the conditions of this ordinance to maintain and use, as now constructed, one (1) Awning(s) projecting over the public right-of-way adjacent to its premises known as 958 W. Diversey Pkwy..

Said Awning(s) at W DIVERSEY measure(s):

One (1) at nine point five eight (9.58) feet in length, and five (5) feet in width for a total of forty-seven point nine (47.9) square feet.

The location of said privilege shall be as shown on prints kept on file with the Department of Business Affairs and Consumer Protection and the Office of the City Clerk.

Said privilege shall be constructed in accordance with plans and specifications approved by the Zoning Department - Signs.

This grant of privilege in the public way shall be subject to the provisions of Section 10-28-015 and all other required provisions of the Municipal Code of Chicago.

The grantee shall pay to the City of Chicago as compensation for the privilege #1112823 herein granted the sum of fifty (\$50.00) per annum in advance.

A 25% penalty will be added for payments received after due date.

The permit holder agrees to hold the City of Chicago harmless for any damage, relocation or replacement costs associated with damage, relocation or removal of private property caused by the City performing work in the public way.

Authority herein given and granted for a period of five (5) years from and after 04/22/2014.

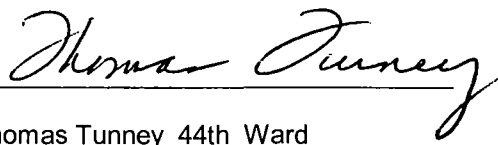
Alderman 
Thomas Tunney 44th Ward

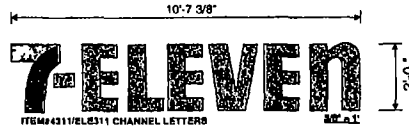

7 COLORS

- PMS 165 Orange**
31925 22 41 Orange Vinyl
- PMS 1797 Red**
3148 28 22 72 Dk Red Vinyl
- PMS 342 Green**
3144 28 22 72 Green Vinyl

(2) NEON INT. ILLUMINATED LETTER SET(S)
***ELEVEN LETTER SET**
 WHITE PLEX FACES W/FIRST SURFACE VINYL APPLIED TO MATCH
 3M#350 28 GREEN
 TRIM CAP TO MATCH GREEN W/RETURNS TO MATCH
 DK BRONZE
***7 LETTER SET**
 WHITE PLEX FACES W/FIRST SURFACE VINYL APPLIED TO MATCH
 3M#330-44 ORANGE
 3M#330-33 RED
 GREEN TRIM CAP W/DK BRONZE RETURNS
 ILLUMINATED W/WHITE NEON
 NO FLUSH MOUNTED TO BUILDING FACES AS SHOWN

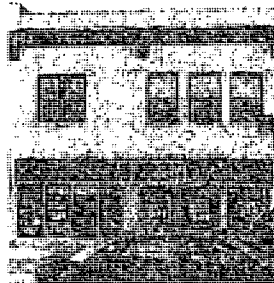

RECOVER EXISTING AWNING
 SUNBRELLA FIRE/ST-FOREST GREEN FABRIC
 PAINT EXISTING FRAMES BLACK
 W/ FIRST SURFACE APPLIED OPAQUE
 GRAPHICS TO MATCH 7-ELEVEN CORPORATE SPECIFICATIONS

NOTE: WHITE BORDER GRAPHIC SIZE 36" W X 37" H 71

DOYLE
 GENERAL SIGN CONTRACTORS
 212 W. PULASKI ST. MIL. WIS. 53001 820-543-9400
 AGRIERON, IL. 61811 FAX 631-543-9403

| DATE | REVISION |
|----------|-----------------------------------|
| 04-02-07 | ADD WHITE BORDER TO KEYSTONE LOGO |
| 05-04-07 | ADD DIMENSION TO KEYSTONE LOGO |
| 07-11-08 | ADD CANOPY DIMENSIONS |

CUSTOMER APPROVAL _____ DATE _____

This design is the original and unpublished work of DOYLE SIGNS, INC and may not be reproduced, copied or modified in any fashion without the expressed written consent from an authorized officer of The Company. The rights in this design may be purchased.

CLIENT: 7-ELEVEN #9008/33898
 ADDRESS: 958 W DIVERSEY STATE: IL DESIGNER: JRS SALESPERSON: TD
 CITY: CHICAGO
 DRWG. NO. 9061 SCALE: NOTED DATE: 02-19-07 SHEET NO. 1 OF 1





City of Chicago



O2014-4666

Office of the City Clerk
Document Tracking Sheet

| | |
|---------------------------------|--|
| Meeting Date: | 5/28/2014 |
| Sponsor(s): | Arena (45) |
| Type: | Ordinance |
| Title: | Awning(s) for House of Hair, Inc. |
| Committee(s) Assignment: | Committee on Transportation and Public Way |

ORDINANCE
HOUSE OF HAIR, INC.
Acct. No. 316721 - 1
Permit No. 1112324

Be It Ordained by the City Council of the City of Chicago:

SECTION 1. Permission and authority are hereby given and granted to HOUSE OF HAIR, INC., upon the terms and subject to the conditions of this ordinance to construct, install, maintain and use one (1) Awning(s) projecting over the public right-of-way adjacent to its premises known as 4761 N. Milwaukee Ave..

Said Awning(s) at Milwaukee measure(s):

One (1) at twenty-four point five (24.5) feet in length, and four (4) feet in width for a total of ninety-eight (98) square feet.

The location of said privilege shall be as shown on prints kept on file with the Department of Business Affairs and Consumer Protection and the Office of the City Clerk.

Said privilege shall be constructed in accordance with plans and specifications approved by the Zoning Department - Signs.

This grant of privilege in the public way shall be subject to the provisions of Section 10-28-015 and all other required provisions of the Municipal Code of Chicago.

The grantee shall pay to the City of Chicago as compensation for the privilege #1112324 herein granted the sum of fifty (\$50.00) per annum in advance.

A 25% penalty will be added for payments received after due date.

The permit holder agrees to hold the City of Chicago harmless for any damage, relocation or replacement costs associated with damage, relocation or removal of private property caused by the City performing work in the public way.

Authority herein given and granted for a period of five (5) years from and after Date of Passage.

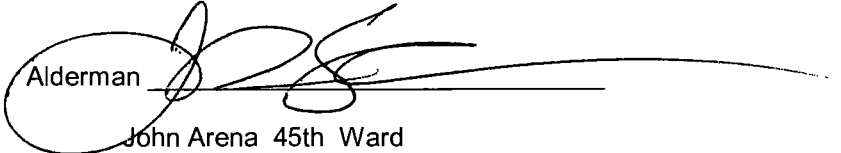
Alderman 
John Arena 45th Ward

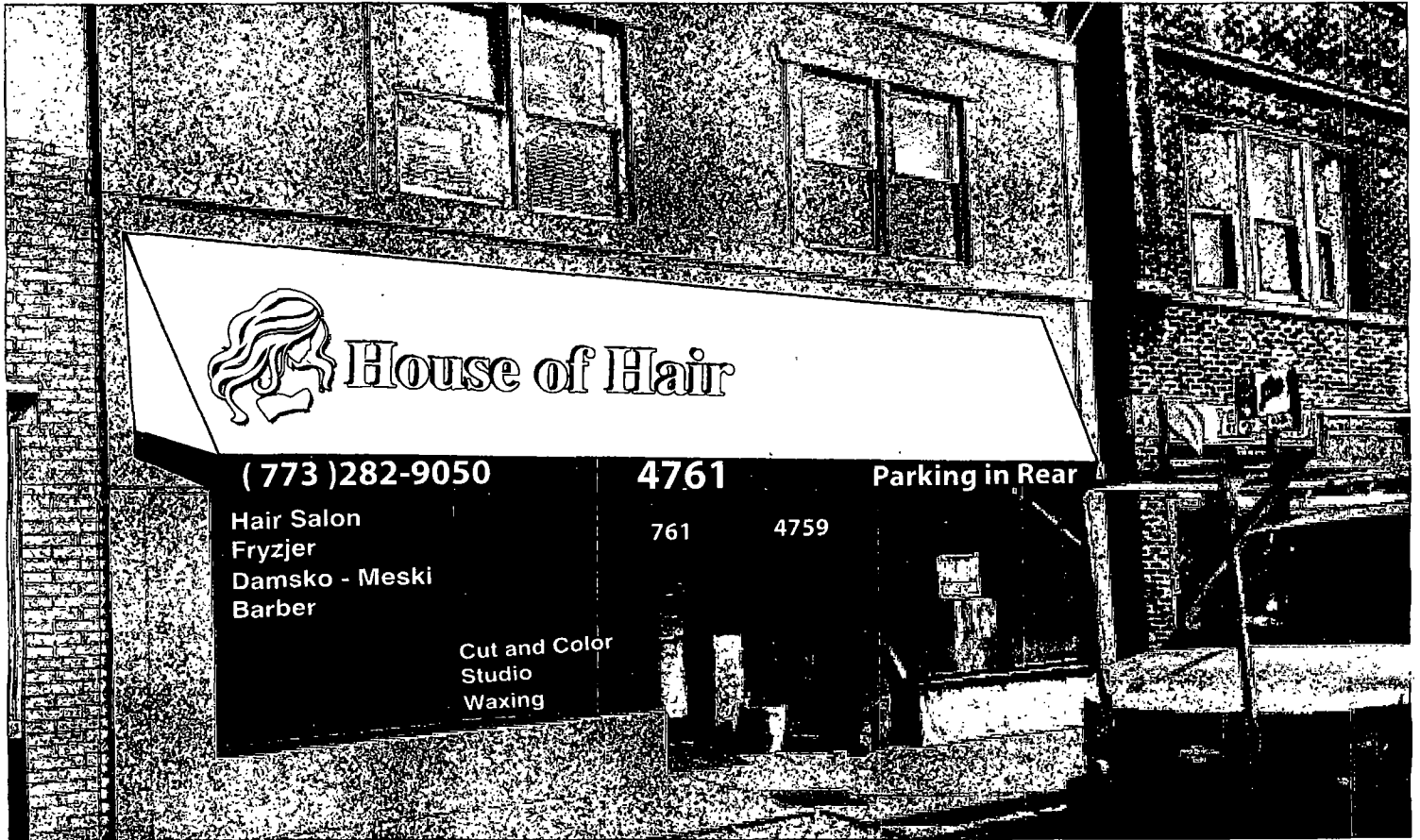

House of Hair

(773)282-9050

Hair Salon
Fryzjer
Damsko - Meski
Barber

Cut and Color
Studio
Waxing

4761

761 4759

Parking in Rear



Department of Business Affairs and Consumer Protection
Small Business Center - Public Way Use Unit
City Hall - 121 N. LaSalle Street, Room 800 • Chicago, IL 60602
(312)-74-GOBIZ (312-744-6249) • (312) 744-1944 (TTY)
<http://www.cityofchicago.org/bacp>

05/28/2014

Alderman **John Arena**
Ward # **45**
City of Chicago
City Hall, Room **305**
121 North LaSalle Street
Chicago, Illinois 60602

Re: An ordinance to use and maintain a portion of the public right-of-way for **one (1) awning(s)** for **HOUSE OF HAIR, INC.**, adjacent to the premises known as **4761 N. Milwaukee Ave.**.

Dear Alderman **John Arena**:

The applicant referenced above has requested the use of the public right-of-way for a **awning(s)**. An ordinance has been prepared by the Department of Business Affairs and Consumer Protection – Small Business Center - Public Way Use Unit for presentation to the City Council. Because this request was made for properties located in your ward, as approved by you as per the attached, I respectfully request that you introduce the attached ordinance at the next City Council meeting.

If you have any questions regarding this ordinance, please contact Anthony Bertuca at (312) 744-5506.

Department of Business Affairs and Consumer Protection



City of Chicago



O2014-4668

Office of the City Clerk

Document Tracking Sheet

| | |
|---------------------------------|--|
| Meeting Date: | 5/28/2014 |
| Sponsor(s): | Arena (45) |
| Type: | Ordinance |
| Title: | Awning(s) for La Pena Restaurante |
| Committee(s) Assignment: | Committee on Transportation and Public Way |

ORDINANCE
LA PENA RESTAURANTE
Acct. No. 209779 - 1
Permit No. 1113093

Be It Ordained by the City Council of the City of Chicago:

SECTION 1. Permission and authority are hereby given and granted to LA PENA RESTAURANTE, upon the terms and subject to the conditions of this ordinance to maintain and use, as now constructed, one (1) Awning(s) projecting over the public right-of-way adjacent to its premises known as 4212-4214 N. Milwaukee Ave..

Said Awning(s) at N. Milwaukee Avenue measure(s):

One (1) at fifty (50) feet in length, and two (2) feet in width for a total of one hundred (100) square feet.

The location of said privilege shall be as shown on prints kept on file with the Department of Business Affairs and Consumer Protection and the Office of the City Clerk.

Said privilege shall be constructed in accordance with plans and specifications approved by the Zoning Department - Signs.

This grant of privilege in the public way shall be subject to the provisions of Section 10-28-015 and all other required provisions of the Municipal Code of Chicago.

The grantee shall pay to the City of Chicago as compensation for the privilege #1113093 herein granted the sum of seventy-five (\$75.00) per annum in advance.

A 25% penalty will be added for payments received after due date.

The permit holder agrees to hold the City of Chicago harmless for any damage, relocation or replacement costs associated with damage, relocation or removal of private property caused by the City performing work in the public way.

Authority herein given and granted for a period of five (5) years from and after 05/24/2014.

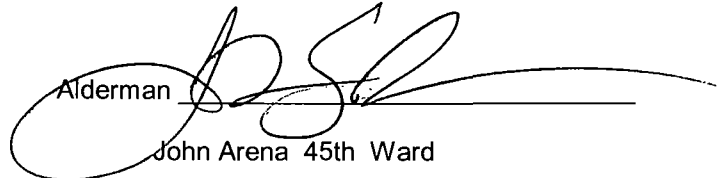
Alderman 
John Arena 45th Ward

LA PEÑA RESTAURANT
4212 N. MILWAUKEE AVE.

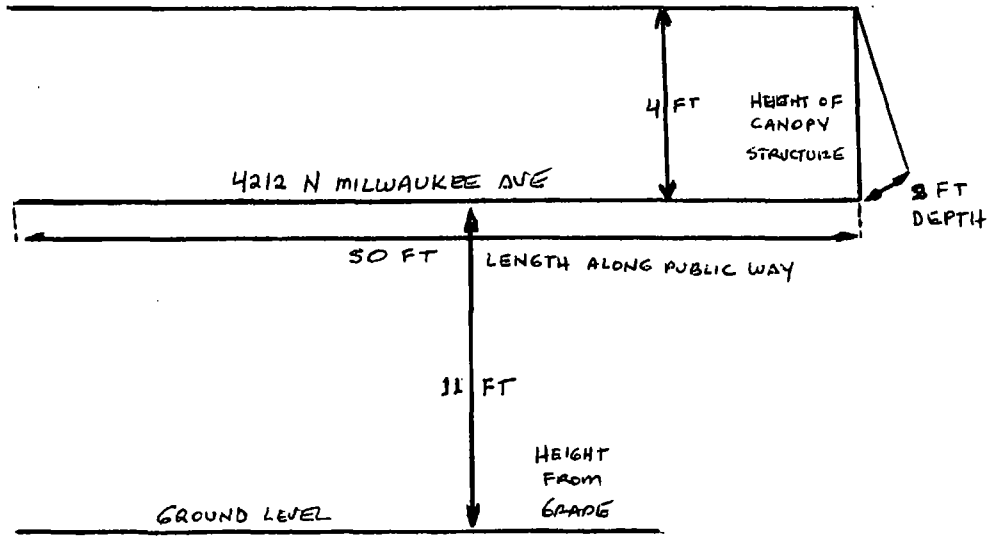



05/28/2014

Alderman **John Arena**
Ward # **45**
City of Chicago
City Hall, Room **305**
121 North LaSalle Street
Chicago, Illinois 60602

Re: An ordinance to use and maintain a portion of the public right-of-way for **one (1) awning(s)** for **LA PENA RESTAURANTE**, adjacent to the premises known as **4212-4214 N. Milwaukee Ave.**.

Dear Alderman **John Arena**:

The applicant referenced above has requested the use of the public right-of-way for a **awning(s)**. An ordinance has been prepared by the Department of Business Affairs and Consumer Protection – Small Business Center - Public Way Use Unit for presentation to the City Council. Because this request was made for properties located in your ward, as approved by you as per the attached, I respectfully request that you introduce the attached ordinance at the next City Council meeting.

If you have any questions regarding this ordinance, please contact Anthony Bertuca at (312) 744-5506.

Department of Business Affairs and Consumer Protection



City of Chicago



O2014-4674

Office of the City Clerk

Document Tracking Sheet

| | |
|---------------------------------|--|
| Meeting Date: | 5/28/2014 |
| Sponsor(s): | Cappleman (46) |
| Type: | Ordinance |
| Title: | Awning(s) for Fifth Third Bank |
| Committee(s) Assignment: | Committee on Transportation and Public Way |

ORDINANCE
FIFTH THIRD BANK
Acct. No. 68597 - 17
Permit No. 1112940

Be It Ordained by the City Council of the City of Chicago:

SECTION 1. Permission and authority are hereby given and granted to FIFTH THIRD BANK, upon the terms and subject to the conditions of this ordinance to maintain and use, as now constructed, two (2) Awning(s) projecting over the public right-of-way adjacent to its premises known as 3601 N. Broadway .

Said Awning(s) at N BROADWAY measure(s):

One (1) at twenty-four point three three (24.33) feet in length, and two point six seven (2.67) feet in width for a total of sixty-four point nine six (64.96) square feet.

Said Awning(s) at N BROADWAY measure(s):

One (1) at twelve point one seven (12.17) feet in length, and two point six seven (2.67) feet in width for a total of thirty-two point four nine (32.49) square feet.

The location of said privilege shall be as shown on prints kept on file with the Department of Business Affairs and Consumer Protection and the Office of the City Clerk.

Said privilege shall be constructed in accordance with plans and specifications approved by the Zoning Department - Signs.

This grant of privilege in the public way shall be subject to the provisions of Section 10-28-015 and all other required provisions of the Municipal Code of Chicago.

The grantee shall pay to the City of Chicago as compensation for the privilege #1112940 herein granted the sum of one hundred (\$100.00) per annum in advance.

A 25% penalty will be added for payments received after due date.

The permit holder agrees to hold the City of Chicago harmless for any damage, relocation or replacement costs associated with damage, relocation or removal of private property caused by the City performing work in the public way.

Authority herein given and granted for a period of five (5) years from and after 04/22/2014.

Alderman _____



James Cappleman 46th Ward

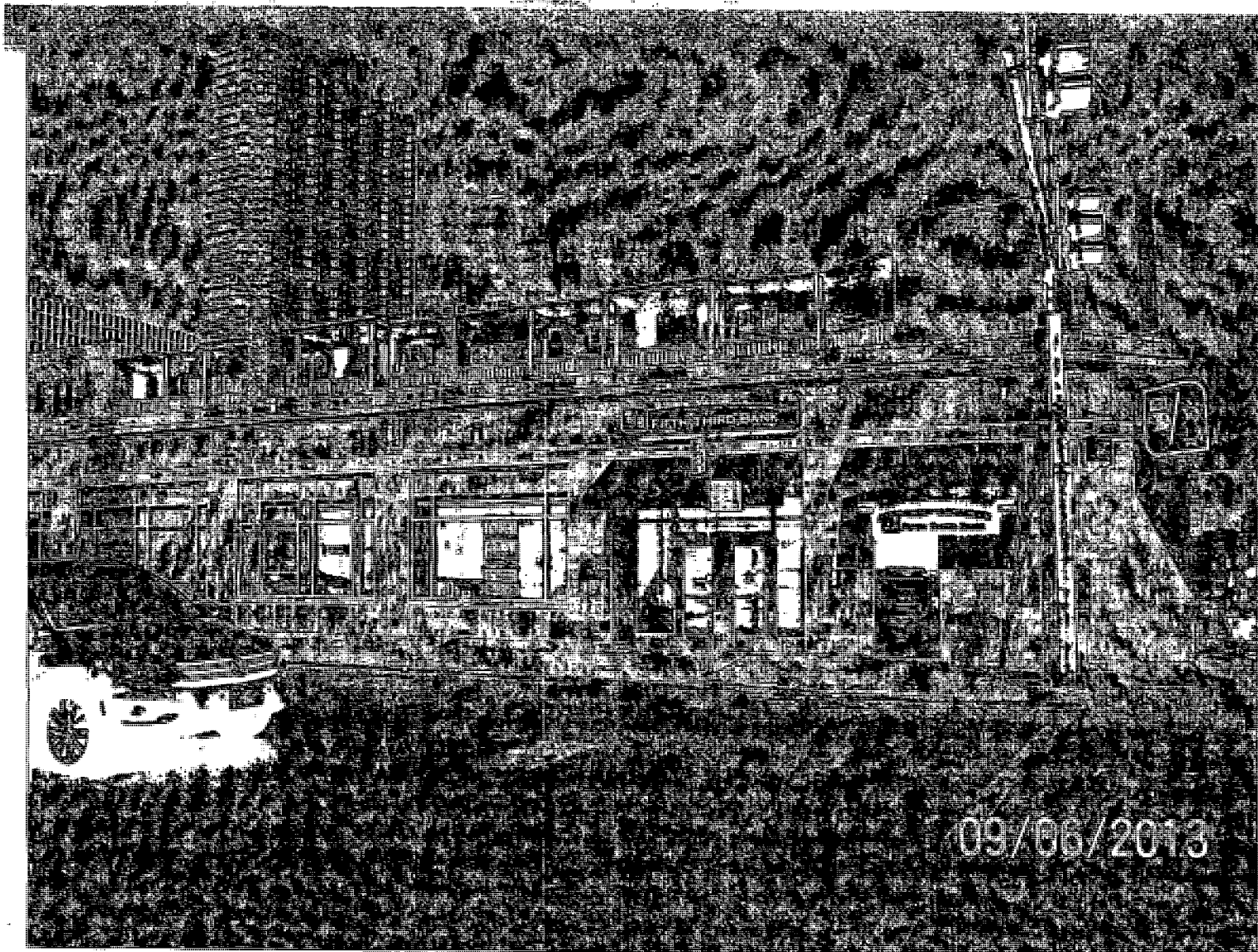



05/28/2014

Alderman **James Cappleman**
Ward # **46**
City of Chicago
City Hall, Room **300**
121 North LaSalle Street
Chicago, Illinois 60602

Re: An ordinance to use and maintain a portion of the public right-of-way for **two (2) awning(s)** for
FIFTH THIRD BANK, adjacent to the premises known as **3601 N. Broadway** .

Dear Alderman **James Cappleman**:

The applicant referenced above has requested the use of the public right-of-way for a **awning(s)**. An ordinance has been prepared by the Department of Business Affairs and Consumer Protection – Small Business Center - Public Way Use Unit for presentation to the City Council. Because this request was made for properties located in your ward, as approved by you as per the attached, I respectfully request that you introduce the attached ordinance at the next City Council meeting.

If you have any questions regarding this ordinance, please contact Anthony Bertuca at (312) 744-5506.

Department of Business Affairs and Consumer Protection



City of Chicago



O2014-4677

Office of the City Clerk

Document Tracking Sheet

| | |
|---------------------------------|--|
| Meeting Date: | 5/28/2014 |
| Sponsor(s): | Pawar (47) |
| Type: | Ordinance |
| Title: | Awning(s) for Eye See Ravenswood, P.C. |
| Committee(s) Assignment: | Committee on Transportation and Public Way |

ORDINANCE
EYE SEE RAVENSWOOD, P.C.
Acct. No. 339177 - 1
Permit No. 1113113

Be It Ordained by the City Council of the City of Chicago:

SECTION 1. Permission and authority are hereby given and granted to EYE SEE RAVENSWOOD, P.C., upon the terms and subject to the conditions of this ordinance to maintain and use, as now constructed, one (1) Awning(s) projecting over the public right-of-way adjacent to its premises known as 4735 N. Damen Ave..

Said Awning(s) at N. Damen measure(s):

One (1) at twelve (12) feet in length, and three (3) feet in width for a total of thirty-six (36) square feet.

The location of said privilege shall be as shown on prints kept on file with the Department of Business Affairs and Consumer Protection and the Office of the City Clerk.

Said privilege shall be constructed in accordance with plans and specifications approved by the Zoning Department - Signs.

This grant of privilege in the public way shall be subject to the provisions of Section 10-28-015 and all other required provisions of the Municipal Code of Chicago.

The grantee shall pay to the City of Chicago as compensation for the privilege #1113113 herein granted the sum of fifty (\$50.00) per annum in advance.

A 25% penalty will be added for payments received after due date.

The permit holder agrees to hold the City of Chicago harmless for any damage, relocation or replacement costs associated with damage, relocation or removal of private property caused by the City performing work in the public way.

Authority herein given and granted for a period of five (5) years from and after 04/22/2014.

Alderman 
Ameya Pawar 47th Ward



APPLICATION TO USE THE PUBLIC RIGHT OF WAY

EXAMPLE OF CANOPY/AWNING DRAWING

CANOPY DRAWINGS

PROPERTY LOCATION: 4735 N Damen Ave
 ORGANIZATION'S NAME: Eye See Raverwood

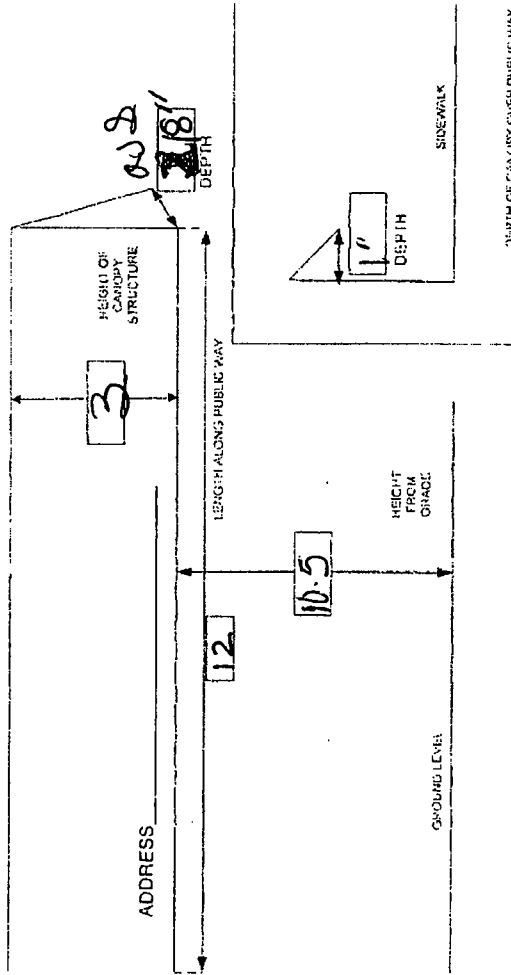



05/28/2014

Alderman **Ameya Pawar**
Ward # 47
City of Chicago
City Hall, Room 300
121 North LaSalle Street
Chicago, Illinois 60602

Re: An ordinance to use and maintain a portion of the public right-of-way for **one (1) awning(s)** for **EYE SEE RAVENSWOOD, P.C.**, adjacent to the premises known as **4735 N. Damen Ave.**.

Dear Alderman **Ameya Pawar**:

The applicant referenced above has requested the use of the public right-of-way for a **awning(s)**. An ordinance has been prepared by the Department of Business Affairs and Consumer Protection – Small Business Center - Public Way Use Unit for presentation to the City Council. Because this request was made for properties located in your ward, as approved by you as per the attached, I respectfully request that you introduce the attached ordinance at the next City Council meeting.

If you have any questions regarding this ordinance, please contact Anthony Bertuca at (312) 744-5506.

Department of Business Affairs and Consumer Protection



City of Chicago



O2014-4680

Office of the City Clerk

Document Tracking Sheet

| | |
|---------------------------------|--|
| Meeting Date: | 5/28/2014 |
| Sponsor(s): | Pawar (47) |
| Type: | Ordinance |
| Title: | Awning(s) for New Asia Restaurant |
| Committee(s) Assignment: | Committee on Transportation and Public Way |

ORDINANCE
NEW ASIA RESTAURANT
Acct. No. 358586 - 2
Permit No. 1111579

Be It Ordained by the City Council of the City of Chicago:

SECTION 1. Permission and authority are hereby given and granted to NEW ASIA RESTAURANT, upon the terms and subject to the conditions of this ordinance to construct, install, maintain and use one (1) Awning(s) projecting over the public right-of-way adjacent to its premises known as 2705 W. Lawrence Ave..

Said Awning(s) at Lawrence measure(s):

One (1) at sixteen (16) feet in length, and three (3) feet in width for a total of forty-eight (48) square feet.

The location of said privilege shall be as shown on prints kept on file with the Department of Business Affairs and Consumer Protection and the Office of the City Clerk.

Said privilege shall be constructed in accordance with plans and specifications approved by the Zoning Department - Signs.

This grant of privilege in the public way shall be subject to the provisions of Section 10-28-015 and all other required provisions of the Municipal Code of Chicago.

The grantee shall pay to the City of Chicago as compensation for the privilege #1111579 herein granted the sum of fifty (\$50.00) per annum in advance.

A 25% penalty will be added for payments received after due date.

The permit holder agrees to hold the City of Chicago harmless for any damage, relocation or replacement costs associated with damage, relocation or removal of private property caused by the City performing work in the public way.

Authority herein given and granted for a period of five (5) years from and after Date of Passage.

Alderman

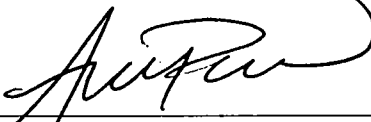

Ameya Pawar 47th Ward



APPLICATION TO USE THE PUBLIC RIGHT OF WAY

EXAMPLE OF CANOPY/AWNING DRAWING

CANOPY DRAWINGS

PROPERTY LOCATION: 2705 W Lawrence

ORGANIZATION'S NAME: _____

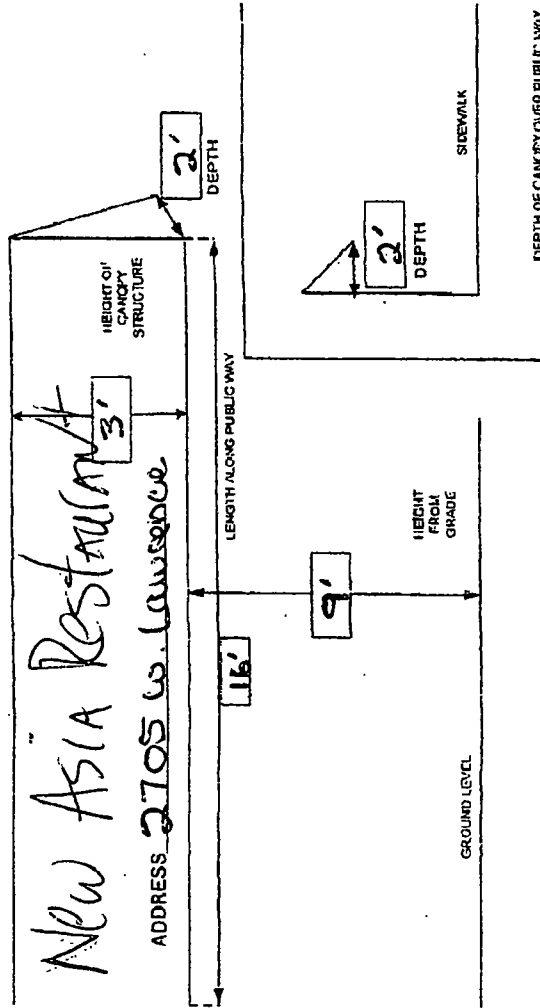



05/28/2014

Alderman Ameya Pawar
Ward # **47**
City of Chicago
City Hall, Room **300**
121 North LaSalle Street
Chicago, Illinois 60602

Re: An ordinance to use and maintain a portion of the public right-of-way for **one (1) awning(s)** for **NEW ASIA RESTAURANT**, adjacent to the premises known as **2705 W. Lawrence Ave.**.

Dear Alderman **Ameya Pawar**:

The applicant referenced above has requested the use of the public right-of-way for a **awning(s)**. An ordinance has been prepared by the Department of Business Affairs and Consumer Protection – Small Business Center - Public Way Use Unit for presentation to the City Council. Because this request was made for properties located in your ward, as approved by you as per the attached, I respectfully request that you introduce the attached ordinance at the next City Council meeting.

If you have any questions regarding this ordinance, please contact Anthony Bertuca at (312) 744-5506.

Department of Business Affairs and Consumer Protection



City of Chicago



O2014-4706

Office of the City Clerk

Document Tracking Sheet

| | |
|---------------------------------|--|
| Meeting Date: | 5/28/2014 |
| Sponsor(s): | Pawar (47) |
| Type: | Ordinance |
| Title: | Awning(s) for Northcenter Rug Cleaning |
| Committee(s) Assignment: | Committee on Transportation and Public Way |

ORDINANCE
NORTHCENTER RUG CLEANING
Acct. No. 275092 - 1
Permit No. 1113101

Be It Ordained by the City Council of the City of Chicago:

SECTION 1. Permission and authority are hereby given and granted to NORTHCENTER RUG CLEANING, upon the terms and subject to the conditions of this ordinance to maintain and use, as now constructed, one (1) Awning(s) projecting over the public right-of-way adjacent to its premises known as 3726 N. Lincoln Ave..

Said Awning(s) at N LINCOLN AVE measure(s):

One (1) at sixteen point seven five (16.75) feet in length, and three (3) feet in width for a total of fifty point two five (50.25) square feet.

The location of said privilege shall be as shown on prints kept on file with the Department of Business Affairs and Consumer Protection and the Office of the City Clerk.

Said privilege shall be constructed in accordance with plans and specifications approved by the Zoning Department - Signs.

This grant of privilege in the public way shall be subject to the provisions of Section 10-28-015 and all other required provisions of the Municipal Code of Chicago.

The grantee shall pay to the City of Chicago as compensation for the privilege #1113101 herein granted the sum of fifty (\$50.00) per annum in advance.

A 25% penalty will be added for payments received after due date.

The permit holder agrees to hold the City of Chicago harmless for any damage, relocation or replacement costs associated with damage, relocation or removal of private property caused by the City performing work in the public way.

Authority herein given and granted for a period of five (5) years from and after 03/18/2014.

Alderman 
Ameya Pawar 47th Ward

3726 N. LINCOLN AVE.

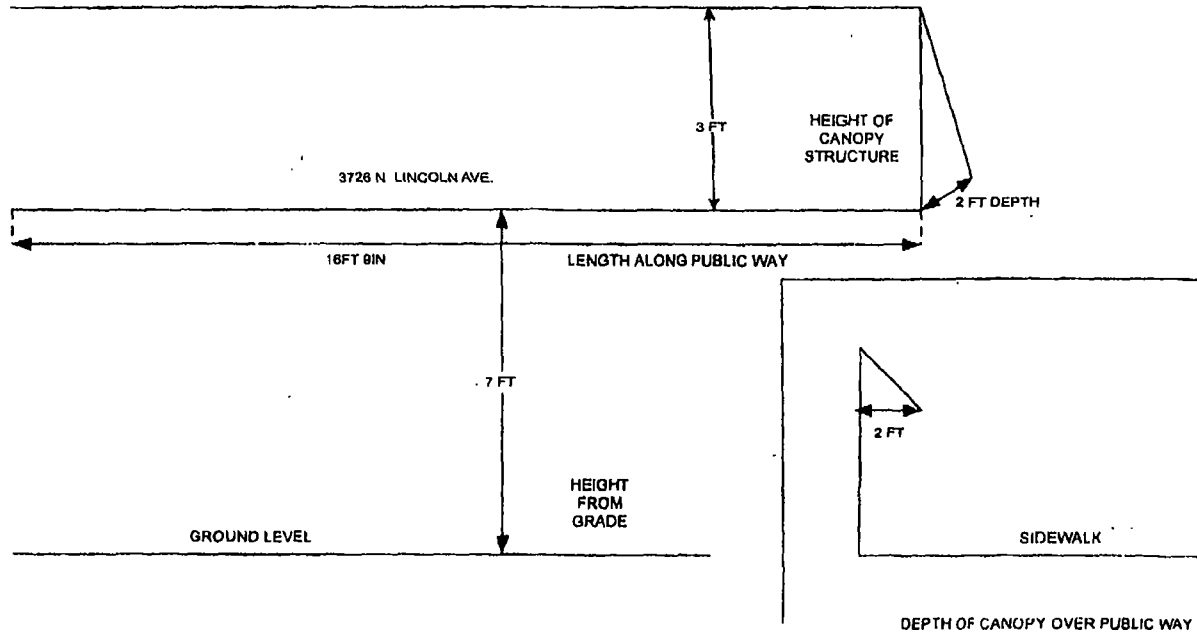



05/28/2014

Alderman **Ameya Pawar**
Ward # **47**
City of Chicago
City Hall, Room **300**
121 North LaSalle Street
Chicago, Illinois 60602

Re: An ordinance to use and maintain a portion of the public right-of-way for **one (1) awning(s)** for
NORTHCENTER RUG CLEANING, adjacent to the premises known as **3726 N. Lincoln Ave.**.

Dear Alderman **Ameya Pawar**:

The applicant referenced above has requested the use of the public right-of-way for a **awning(s)**. An ordinance has been prepared by the Department of Business Affairs and Consumer Protection – Small Business Center - Public Way Use Unit for presentation to the City Council. Because this request was made for properties located in your ward, as approved by you as per the attached, I respectfully request that you introduce the attached ordinance at the next City Council meeting.

If you have any questions regarding this ordinance, please contact Anthony Bertuca at (312) 744-5506.

Department of Business Affairs and Consumer Protection



City of Chicago



O2014-4709

Office of the City Clerk Document Tracking Sheet

| | |
|---------------------------------|--|
| Meeting Date: | 5/28/2014 |
| Sponsor(s): | Pawar (47) |
| Type: | Ordinance |
| Title: | Awning(s) for Ricochets |
| Committee(s) Assignment: | Committee on Transportation and Public Way |

ORDINANCE
RICOCHETS
Acct. No. 31709 - 1
Permit No. 1113011

Be It Ordained by the City Council of the City of Chicago:

SECTION 1. Permission and authority are hereby given and granted to RICOCHETS, upon the terms and subject to the conditions of this ordinance to maintain and use, as now constructed, two (2) Awning(s) projecting over the public right-of-way adjacent to its premises known as 4644 N. Lincoln Ave..

Said Awning(s) at N. Lincoln Avenue measure(s):

One (1) at forty (40) feet in length, and two point five (2.5) feet in width for a total of one hundred (100) square feet.

Said Awning(s) at N. Eastwood measure(s):

One (1) at four (4) feet in length, and two point five (2.5) feet in width for a total of ten (10) square feet.

The location of said privilege shall be as shown on prints kept on file with the Department of Business Affairs and Consumer Protection and the Office of the City Clerk.

Said privilege shall be constructed in accordance with plans and specifications approved by the Zoning Department - Signs.

This grant of privilege in the public way shall be subject to the provisions of Section 10-28-015 and all other required provisions of the Municipal Code of Chicago.

The grantee shall pay to the City of Chicago as compensation for the privilege #1113011 herein granted the sum of one hundred fifteen (\$115.00) per annum in advance.

A 25% penalty will be added for payments received after due date.

The permit holder agrees to hold the City of Chicago harmless for any damage, relocation or replacement costs associated with damage, relocation or removal of private property caused by the City performing work in the public way.

Authority herein given and granted for a period of five (5) years from and after 04/22/2014.

Alderman

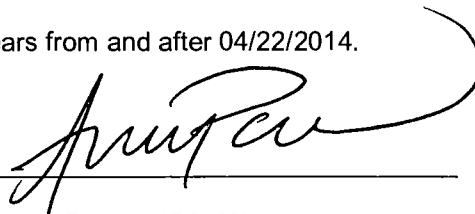

Ameya Pawar 47th Ward

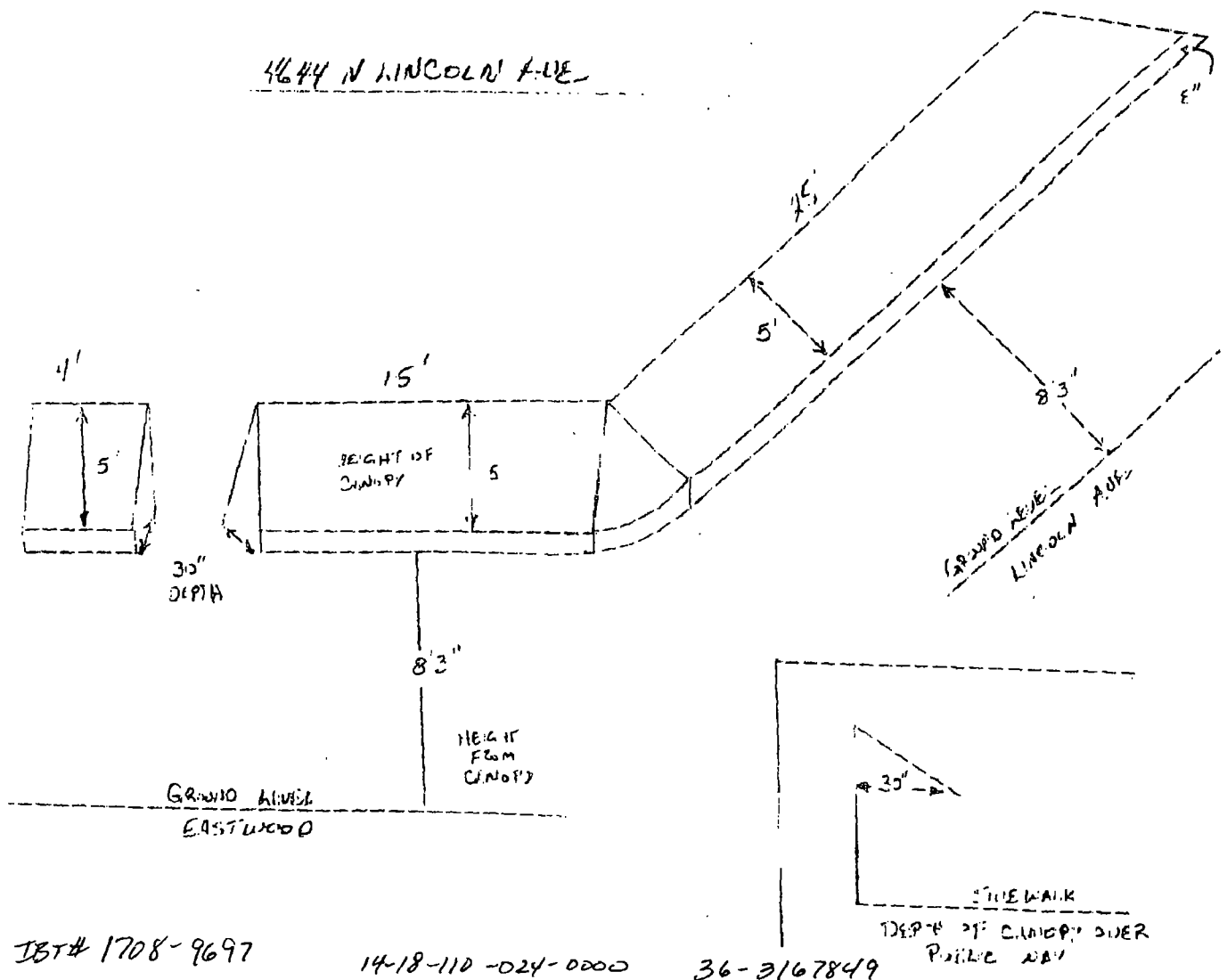

IBT# 1708-9697

14-18-110-024-0000

36-3167849



05/28/2014

Alderman **Ameya Pawar**
Ward # **47**
City of Chicago
City Hall, Room **300**
121 North LaSalle Street
Chicago, Illinois 60602

Re: An ordinance to use and maintain a portion of the public right-of-way for **two (2) awning(s)** for **RICOCHETS**, adjacent to the premises known as **4644 N. Lincoln Ave.**.

Dear Alderman **Ameya Pawar**:

The applicant referenced above has requested the use of the public right-of-way for a **awning(s)**. An ordinance has been prepared by the Department of Business Affairs and Consumer Protection – Small Business Center - Public Way Use Unit for presentation to the City Council. Because this request was made for properties located in your ward, as approved by you as per the attached, I respectfully request that you introduce the attached ordinance at the next City Council meeting.

If you have any questions regarding this ordinance, please contact Anthony Bertuca at (312) 744-5506.

Department of Business Affairs and Consumer Protection



City of Chicago



O2014-4712

Office of the City Clerk
Document Tracking Sheet

| | |
|---------------------------------|--|
| Meeting Date: | 5/28/2014 |
| Sponsor(s): | Pawar (47) |
| Type: | Ordinance |
| Title: | Awning(s) for Thai Oscar |
| Committee(s) Assignment: | Committee on Transportation and Public Way |

ORDINANCE
THAI OSCAR
Acct. No. 323729 - 1
Permit No. 1112849

Be It Ordained by the City Council of the City of Chicago:

SECTION 1. Permission and authority are hereby given and granted to THAI OSCAR, upon the terms and subject to the conditions of this ordinance to maintain and use, as now constructed, one (1) Awning(s) projecting over the public right-of-way adjacent to its premises known as 4638 N. Western Ave..

Said Awning(s) at N. Western Avenue measure(s):

One (1) at twenty (20) feet in length, and two (2) feet in width for a total of forty (40) square feet.

The location of said privilege shall be as shown on prints kept on file with the Department of Business Affairs and Consumer Protection and the Office of the City Clerk.

Said privilege shall be constructed in accordance with plans and specifications approved by the Zoning Department - Signs.

This grant of privilege in the public way shall be subject to the provisions of Section 10-28-015 and all other required provisions of the Municipal Code of Chicago.

The grantee shall pay to the City of Chicago as compensation for the privilege #1112849 herein granted the sum of fifty (\$50.00) per annum in advance.

A 25% penalty will be added for payments received after due date.

The permit holder agrees to hold the City of Chicago harmless for any damage, relocation or replacement costs associated with damage, relocation or removal of private property caused by the City performing work in the public way.

Authority herein given and granted for a period of five (5) years from and after 11/19/2013.

Alderman



Ameva Pawar 47th Ward

01/15/2014 (Date)

323729 (Acct. #)

1082313 (Permit #)

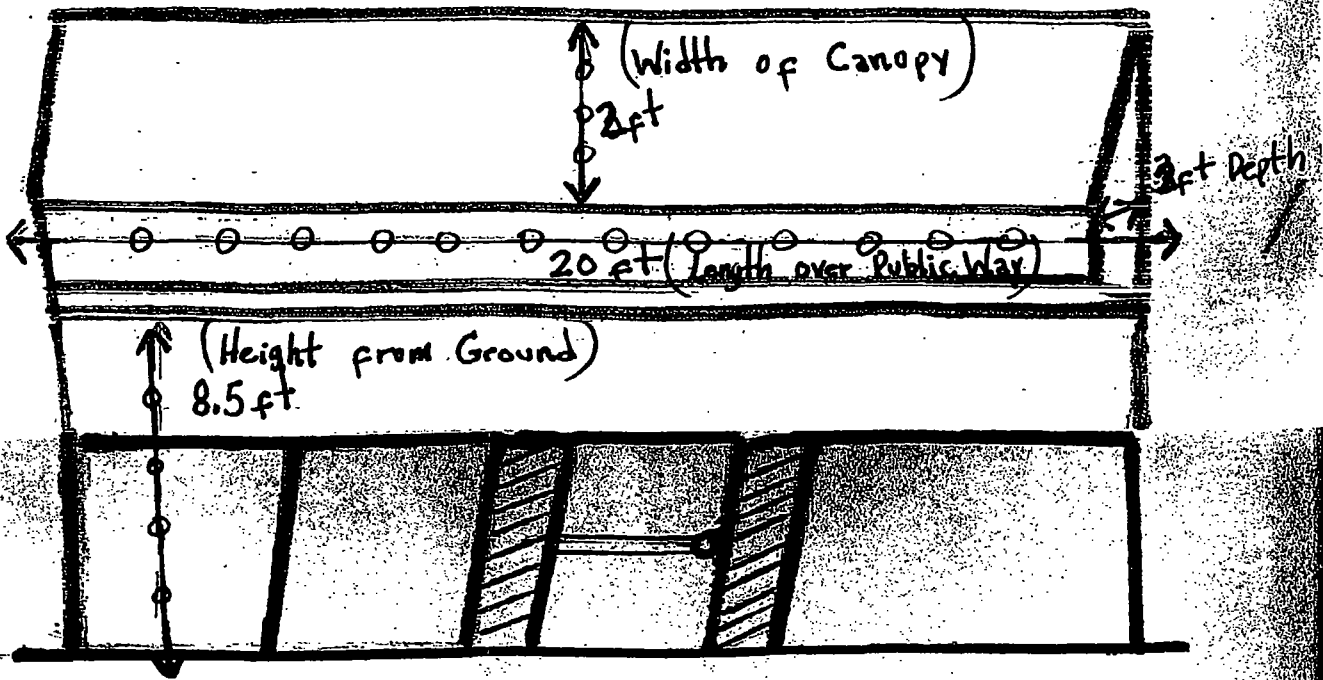
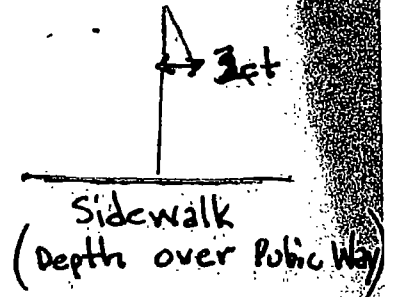
Thai Oscar Restaurant
4628 N. Western Ave
Chicago IL 60625



Length = 20'
 Width = 2'
 Depth = 3'
 Height = 8.5'

Western Avenue



Department of Business Affairs and Consumer Protection
Small Business Center - Public Way Use Unit
City Hall - 121 N. LaSalle Street, Room 800 • Chicago, IL 60602
(312)-74-GOBIZ (312-744-6249) • (312) 744-1944 (TTY)
<http://www.cityofchicago.org/bacp>

05/28/2014

Alderman Ameya Pawar
Ward # 47
City of Chicago
City Hall, Room 300
121 North LaSalle Street
Chicago, Illinois 60602

Re: An ordinance to use and maintain a portion of the public right-of-way for **one (1) awning(s)** for **THAI OSCAR**, adjacent to the premises known as **4638 N. Western Ave.**

Dear Alderman Ameya Pawar:

The applicant referenced above has requested the use of the public right-of-way for a **awning(s)**. An ordinance has been prepared by the Department of Business Affairs and Consumer Protection – Small Business Center - Public Way Use Unit for presentation to the City Council. Because this request was made for properties located in your ward, as approved by you as per the attached, I respectfully request that you introduce the attached ordinance at the next City Council meeting.

If you have any questions regarding this ordinance, please contact Anthony Bertuca at (312) 744-5506.

Department of Business Affairs and Consumer Protection



City of Chicago



O2014-4714

Office of the City Clerk

Document Tracking Sheet

| | |
|---------------------------------|--|
| Meeting Date: | 5/28/2014 |
| Sponsor(s): | Pawar (47) |
| Type: | Ordinance |
| Title: | Awning(s) for Winona Cleaners, Inc. |
| Committee(s) Assignment: | Committee on Transportation and Public Way |

ORDINANCE
WINONA CLEANERS, INC.
Acct. No. 388878 - 1
Permit No. 1113073

Be It Ordained by the City Council of the City of Chicago:

SECTION 1. Permission and authority are hereby given and granted to WINONA CLEANERS, INC., upon the terms and subject to the conditions of this ordinance to maintain and use, as now constructed, one (1) Awning(s) projecting over the public right-of-way adjacent to its premises known as 5133 N. Clark St..

Said Awning(s) at N CLARK ST measure(s):

One (1) at fifty-two (52) feet in length, and four (4) feet in width for a total of two hundred eight (208) square feet.

The location of said privilege shall be as shown on prints kept on file with the Department of Business Affairs and Consumer Protection and the Office of the City Clerk.

Said privilege shall be constructed in accordance with plans and specifications approved by the Zoning Department - Signs.

This grant of privilege in the public way shall be subject to the provisions of Section 10-28-015 and all other required provisions of the Municipal Code of Chicago.

The grantee shall pay to the City of Chicago as compensation for the privilege #1113073 herein granted the sum of seventy-seven (\$77.00) per annum in advance.

A 25% penalty will be added for payments received after due date.

The permit holder agrees to hold the City of Chicago harmless for any damage, relocation or replacement costs associated with damage, relocation or removal of private property caused by the City performing work in the public way.

Authority herein given and granted for a period of five (5) years from and after 04/22/2014.

Alderman



Ameya Pawar 47th Ward

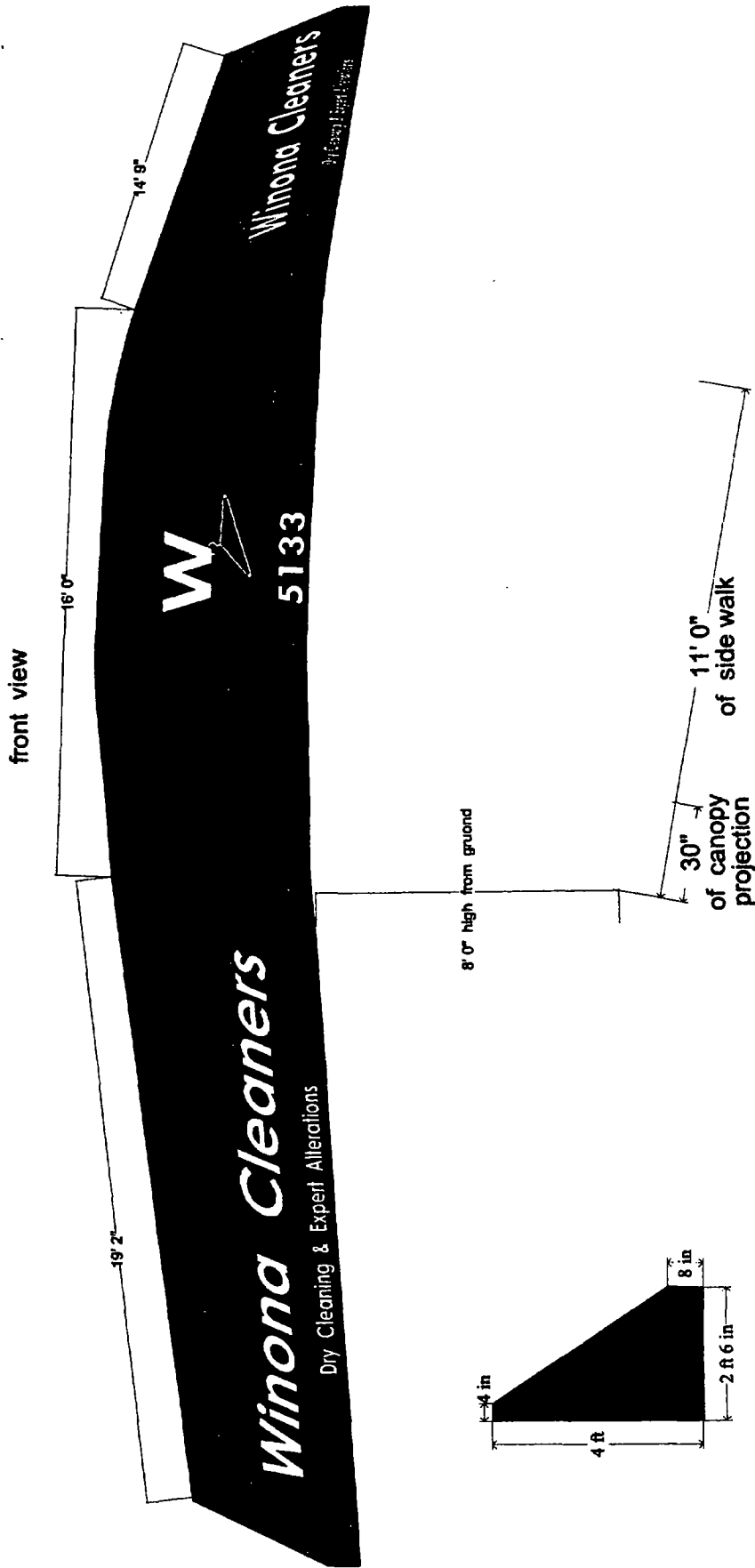

Draw to: Winona Cleaners
BY: Awnings USA
awningsusa@awglobal.net
(773) 471-1163
09/26/08



05/28/2014

Alderman **Ameya Pawar**
Ward # 47
City of Chicago
City Hall, Room 300
121 North LaSalle Street
Chicago, Illinois 60602

Re: An ordinance to use and maintain a portion of the public right-of-way for **one (1) awning(s)** for **WINONA CLEANERS, INC.**, adjacent to the premises known as **5133 N. Clark St.**

Dear Alderman **Ameya Pawar**:

The applicant referenced above has requested the use of the public right-of-way for a **awning(s)**. An ordinance has been prepared by the Department of Business Affairs and Consumer Protection – Small Business Center - Public Way Use Unit for presentation to the City Council. Because this request was made for properties located in your ward, as approved by you as per the attached, I respectfully request that you introduce the attached ordinance at the next City Council meeting.

If you have any questions regarding this ordinance, please contact Anthony Bertuca at (312) 744-5506.

Department of Business Affairs and Consumer Protection



City of Chicago



O2014-4717

Office of the City Clerk

Document Tracking Sheet

| | |
|---------------------------------|--|
| Meeting Date: | 5/28/2014 |
| Sponsor(s): | Osterman (48) |
| Type: | Ordinance |
| Title: | Awning(s) for Know No Limits |
| Committee(s) Assignment: | Committee on Transportation and Public Way |

ORDINANCE
KNOW NO LIMITS
Acct. No. 45530 - 2
Permit No. 1112795

Be It Ordained by the City Council of the City of Chicago:

SECTION 1. Permission and authority are hereby given and granted to KNOW NO LIMITS, upon the terms and subject to the conditions of this ordinance to maintain and use, as now constructed, four (4) Awning(s) projecting over the public right-of-way adjacent to its premises known as 6125 N. Clark St..

Said Awning(s) at N. Clark measure(s):

One (1) at twenty-four (24) feet in length, and two (2) feet in width for a total of forty-eight (48) square feet.

Said Awning(s) at N. Clark measure(s):

Two (2) at twenty (20) feet in length, and two (2) feet in width for a total of eighty (80) square feet.

Said Awning(s) at N. Clark measure(s):

One (1) at eleven (11) feet in length, and two (2) feet in width for a total of twenty-two (22) square feet.

The location of said privilege shall be as shown on prints kept on file with the Department of Business Affairs and Consumer Protection and the Office of the City Clerk.

Said privilege shall be constructed in accordance with plans and specifications approved by the Zoning Department - Signs.

This grant of privilege in the public way shall be subject to the provisions of Section 10-28-015 and all other required provisions of the Municipal Code of Chicago.

The grantee shall pay to the City of Chicago as compensation for the privilege #1112795 herein granted the sum of one hundred seventy-five (\$175.00) per annum in advance.

A 25% penalty will be added for payments received after due date.

The permit holder agrees to hold the City of Chicago harmless for any damage, relocation or replacement costs associated with damage, relocation or removal of private property caused by the City performing work in the public way.

Authority herein given and granted for a period of five (5) years from and after 04/22/2014.

Alderman _____



Harry Osterman 48th Ward

Account #
45530-2

Permit #
1086011

KNOW NO LIMITS

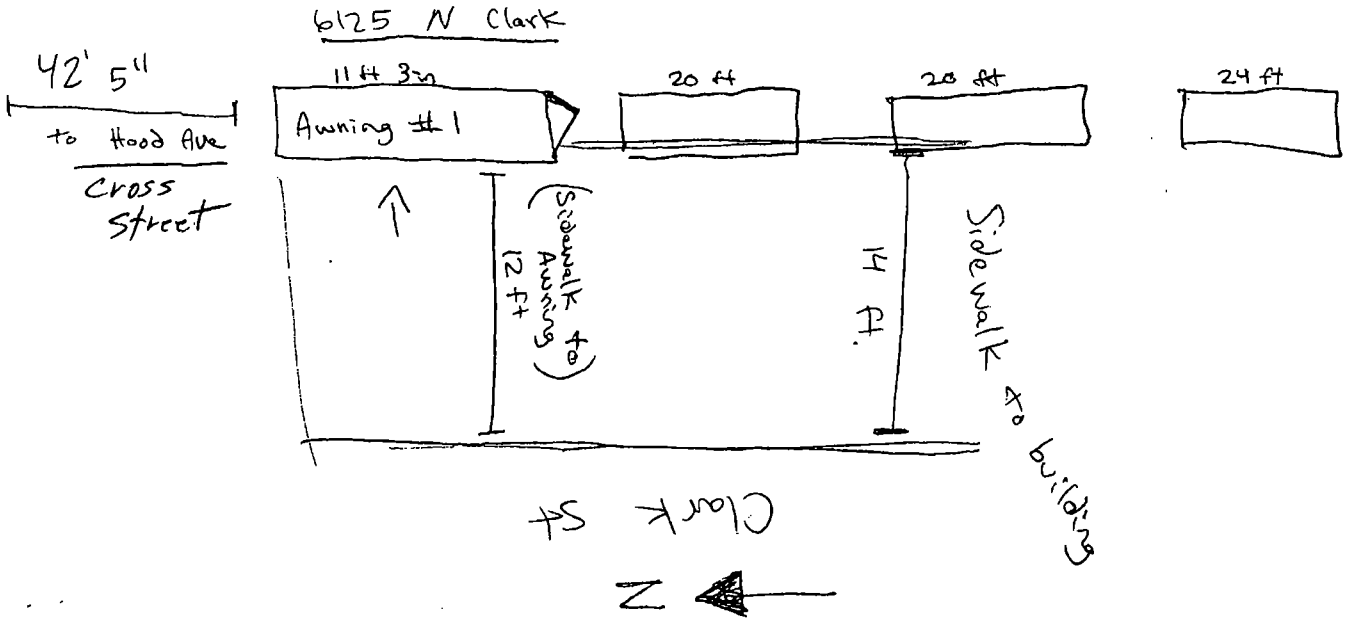

Q



05/28/2014

Alderman **Harry Osterman**
Ward # **48**
City of Chicago
City Hall, Room **300**
121 North LaSalle Street
Chicago, Illinois 60602

Re: An ordinance to use and maintain a portion of the public right-of-way for **four (4) awning(s)** for **KNOW NO LIMITS**, adjacent to the premises known as **6125 N. Clark St.**

Dear Alderman **Harry Osterman**:

The applicant referenced above has requested the use of the public right-of-way for a **awning(s)**. An ordinance has been prepared by the Department of Business Affairs and Consumer Protection – Small Business Center - Public Way Use Unit for presentation to the City Council. Because this request was made for properties located in your ward, as approved by you as per the attached, I respectfully request that you introduce the attached ordinance at the next City Council meeting.

If you have any questions regarding this ordinance, please contact Anthony Bertuca at (312) 744-5506.

Department of Business Affairs and Consumer Protection



City of Chicago



O2014-4721

Office of the City Clerk Document Tracking Sheet

| | |
|---------------------------------|--|
| Meeting Date: | 5/28/2014 |
| Sponsor(s): | Osterman (48) |
| Type: | Ordinance |
| Title: | Awning(s) for Vincent |
| Committee(s) Assignment: | Committee on Transportation and Public Way |

ORDINANCE
VINCENT
Acct. No. 17492 - 1
Permit No. 1112825

Be It Ordained by the City Council of the City of Chicago:

SECTION 1. Permission and authority are hereby given and granted to VINCENT, upon the terms and subject to the conditions of this ordinance to maintain and use, as now constructed, three (3) Awning(s) projecting over the public right-of-way adjacent to its premises known as 1475 W. Balmoral Ave..

Said Awning(s) at W. BALMORAL measure(s):

Three (3) at nine point two five (9.25) feet in length, and three (3) feet in width for a total of eighty-three point two five (83.25) square feet.

The location of said privilege shall be as shown on prints kept on file with the Department of Business Affairs and Consumer Protection and the Office of the City Clerk.

Said privilege shall be constructed in accordance with plans and specifications approved by the Zoning Department - Signs.

This grant of privilege in the public way shall be subject to the provisions of Section 10-28-015 and all other required provisions of the Municipal Code of Chicago.

The grantee shall pay to the City of Chicago as compensation for the privilege #1112825 herein granted the sum of one hundred fifty (\$150.00) per annum in advance.

A 25% penalty will be added for payments received after due date.

The permit holder agrees to hold the City of Chicago harmless for any damage, relocation or replacement costs associated with damage, relocation or removal of private property caused by the City performing work in the public way.

Authority herein given and granted for a period of five (5) years from and after 01/10/2014.

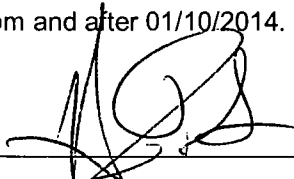
Alderman _____

Harry Osterman 48th Ward

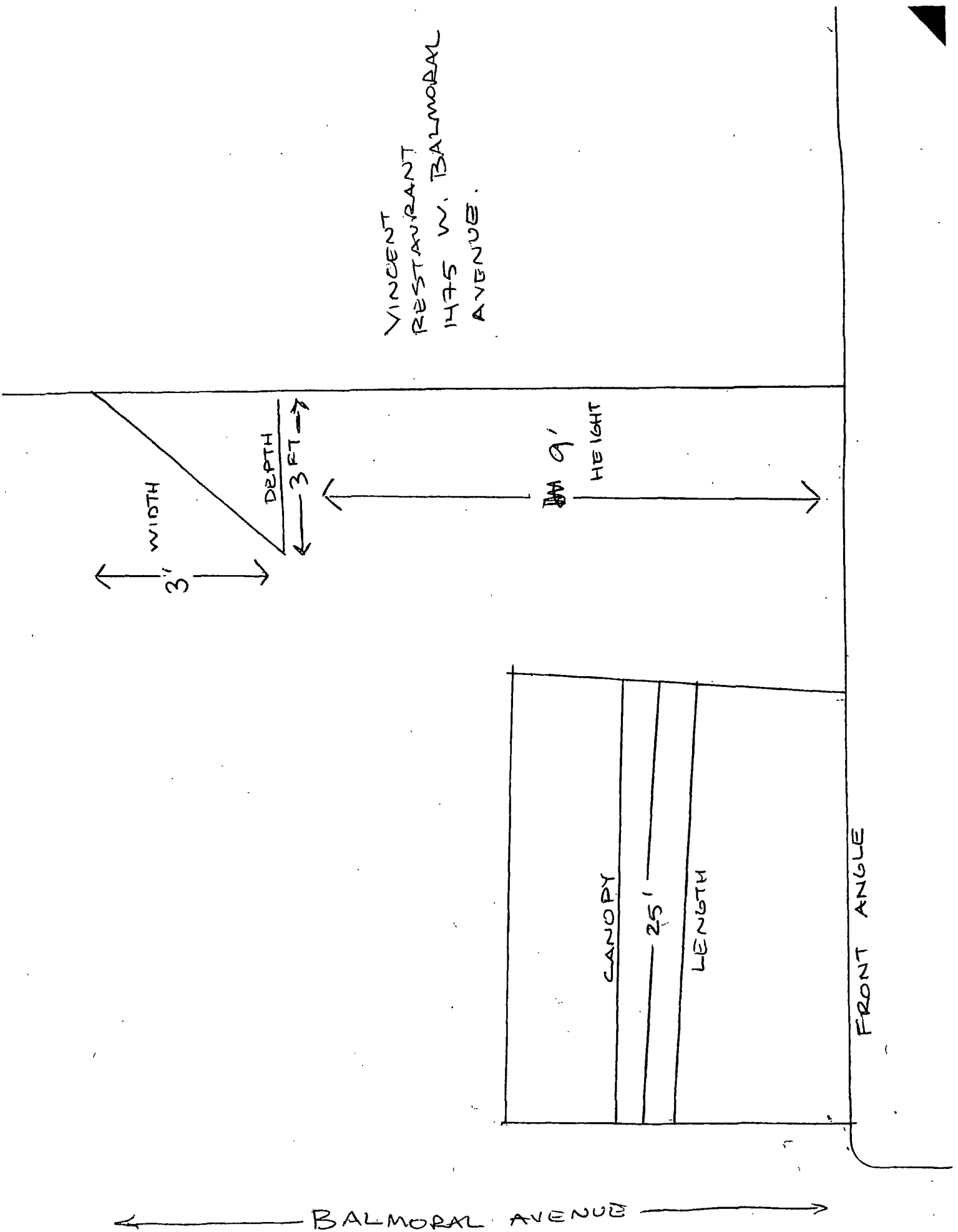
VINCENT
RESTAURANT
1475 W. BALMORAL
AVENUE.





05/28/2014

Alderman **Harry Osterman**
Ward # **48**
City of Chicago
City Hall, Room **300**
121 North LaSalle Street
Chicago, Illinois 60602

Re: An ordinance to use and maintain a portion of the public right-of-way for **three (3) awning(s)** for **VINCENT**, adjacent to the premises known as **1475 W. Balmoral Ave.**.

Dear Alderman **Harry Osterman**:

The applicant referenced above has requested the use of the public right-of-way for a **awning(s)**. An ordinance has been prepared by the Department of Business Affairs and Consumer Protection – Small Business Center - Public Way Use Unit for presentation to the City Council. Because this request was made for properties located in your ward, as approved by you as per the attached, I respectfully request that you introduce the attached ordinance at the next City Council meeting.

If you have any questions regarding this ordinance, please contact Anthony Bertuca at (312) 744-5506.

Department of Business Affairs and Consumer Protection



City of Chicago



O2014-4535

Office of the City Clerk

Document Tracking Sheet

| | |
|---------------------------------|--|
| Meeting Date: | 5/28/2014 |
| Sponsor(s): | Moore (49) |
| Type: | Ordinance |
| Title: | Awning(s) for Grooming by Galdy |
| Committee(s) Assignment: | Committee on Transportation and Public Way |

ORDINANCE
GROOMING BY GALDY
Acct. No. 359080 - 1
Permit No. 1099812

Be It Ordained by the City Council of the City of Chicago:

SECTION 1. Permission and authority are hereby given and granted to GROOMING BY GALDY, upon the terms and subject to the conditions of this ordinance to construct, install, maintain and use two (2) Awning(s) projecting over the public right-of-way adjacent to its premises known as 7007 N. Sheridan Rd..

Said Awning(s) at N. Sheridan Rd measure(s):

Two (2) at fourteen (14) feet in length, and two point five (2.5) feet in width for a total of seventy (70) square feet.

The location of said privilege shall be as shown on prints kept on file with the Department of Business Affairs and Consumer Protection and the Office of the City Clerk.

Said privilege shall be constructed in accordance with plans and specifications approved by the Zoning Department - Signs.

This grant of privilege in the public way shall be subject to the provisions of Section 10-28-015 and all other required provisions of the Municipal Code of Chicago.

The grantee shall pay to the City of Chicago as compensation for the privilege #1099812 herein granted the sum of one hundred (\$100.00) per annum in advance.

A 25% penalty will be added for payments received after due date.

The permit holder agrees to hold the City of Chicago harmless for any damage, relocation or replacement costs associated with damage, relocation or removal of private property caused by the City performing work in the public way.

Authority herein given and granted for a period of five (5) years from and after Date of Passage.

Alderman

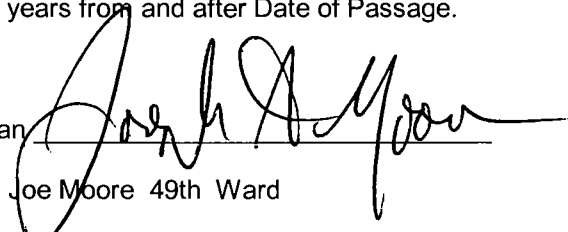
Joe Moore 49th Ward

New Awnings at 7007 N. Sheridan Chicago IL. 60626
Two Awnings 14' wide 30" high 30" out



14' wide

14' wide





05/28/2014

Alderman **Joe Moore**
Ward # **49**
City of Chicago
City Hall, Room **300**
121 North LaSalle Street
Chicago, Illinois 60602

Re: An ordinance to use and maintain a portion of the public right-of-way for **two (2) awning(s)** for **GROOMING BY GALDY**, adjacent to the premises known as **7007 N. Sheridan Rd.**

Dear Alderman **Joe Moore**:

The applicant referenced above has requested the use of the public right-of-way for a **awning(s)**. An ordinance has been prepared by the Department of Business Affairs and Consumer Protection – Small Business Center - Public Way Use Unit for presentation to the City Council. Because this request was made for properties located in your ward, as approved by you as per the attached, I respectfully request that you introduce the attached ordinance at the next City Council meeting.

If you have any questions regarding this ordinance, please contact Anthony Bertuca at (312) 744-5506.

Department of Business Affairs and Consumer Protection



City of Chicago



O2014-4722

Office of the City Clerk Document Tracking Sheet

| | |
|---------------------------------|--|
| Meeting Date: | 5/28/2014 |
| Sponsor(s): | Silverstein (50) |
| Type: | Ordinance |
| Title: | Awning(s) for Par Birdie Foods |
| Committee(s) Assignment: | Committee on Transportation and Public Way |

ORDINANCE
PAR BIRDIE FOODS
Acct. No. 11464 - 1
Permit No. 1110222

Be It Ordained by the City Council of the City of Chicago:

SECTION 1. Permission and authority are hereby given and granted to PAR BIRDIE FOODS, upon the terms and subject to the conditions of this ordinance to maintain and use, as now constructed, one (1) Awning(s) projecting over the public right-of-way adjacent to its premises known as 2234 W. Devon Ave..

Said Awning(s) at W DEVON AVE measure(s):

One (1) at sixty (60) feet in length, and three (3) feet in width for a total of one hundred eighty (180) square feet.

The location of said privilege shall be as shown on prints kept on file with the Department of Business Affairs and Consumer Protection and the Office of the City Clerk.

Said privilege shall be constructed in accordance with plans and specifications approved by the Zoning Department - Signs.

This grant of privilege in the public way shall be subject to the provisions of Section 10-28-015 and all other required provisions of the Municipal Code of Chicago.

The grantee shall pay to the City of Chicago as compensation for the privilege #1110222 herein granted the sum of eighty-five (\$85.00) per annum in advance.

A 25% penalty will be added for payments received after due date.

The permit holder agrees to hold the City of Chicago harmless for any damage, relocation or replacement costs associated with damage, relocation or removal of private property caused by the City performing work in the public way.

Authority herein given and granted for a period of five (5) years from and after 11/19/2013.

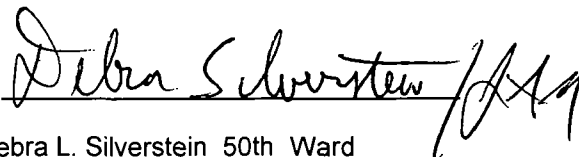
Alderman 
Debra L. Silverstein 50th Ward





City of Chicago



O2014-4524

Office of the City Clerk

Document Tracking Sheet

| | |
|---------------------------------|--|
| Meeting Date: | 5/28/2014 |
| Sponsor(s): | Moreno (1) |
| Type: | Ordinance |
| Title: | Canopy(s) for Fringe A Hair Salon, Inc. |
| Committee(s) Assignment: | Committee on Transportation and Public Way |

ORDINANCE
FRINGE A HAIR SALON, INC
Acct. No. 245513 - 1
Permit No. 1112733

Be It Ordained by the City Council of the City of Chicago:

SECTION 1. Permission and authority are hereby given and granted to FRINGE A HAIR SALON, INC, upon the terms and subject to the conditions of this ordinance to maintain and use, as now constructed, one (1) Canopy(s) projecting over the public right-of-way adjacent to its premises known as 1437 N. Milwaukee Ave..

Said Canopy(s) at N MILWAUKEE AVE measure(s):

One (1) at twenty-five (25) feet in length, and seven point five (7.5) feet in width for a total of one hundred eighty-seven point five (187.5) square feet.

The location of said privilege shall be as shown on prints kept on file with the Department of Business Affairs and Consumer Protection and the Office of the City Clerk.

Said privilege shall be constructed in accordance with plans and specifications approved by the Zoning Department - Signs.

This grant of privilege in the public way shall be subject to the provisions of Section 10-28-015 and all other required provisions of the Municipal Code of Chicago.

The grantee shall pay to the City of Chicago as compensation for the privilege #1112733 herein granted the sum of fifty (\$50.00) per annum in advance.

A 25% penalty will be added for payments received after due date.

The permit holder agrees to hold the City of Chicago harmless for any damage, relocation or replacement costs associated with damage, relocation or removal of private property caused by the City performing work in the public way.

Authority herein given and granted for a period of five (5) years from and after 04/22/2014.

Alderman _____

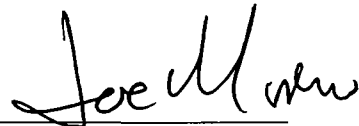

Proco Joe Moreno 1st Ward

1437 N. MILWAUKEE AVE.
CHICAGO, IL 60642

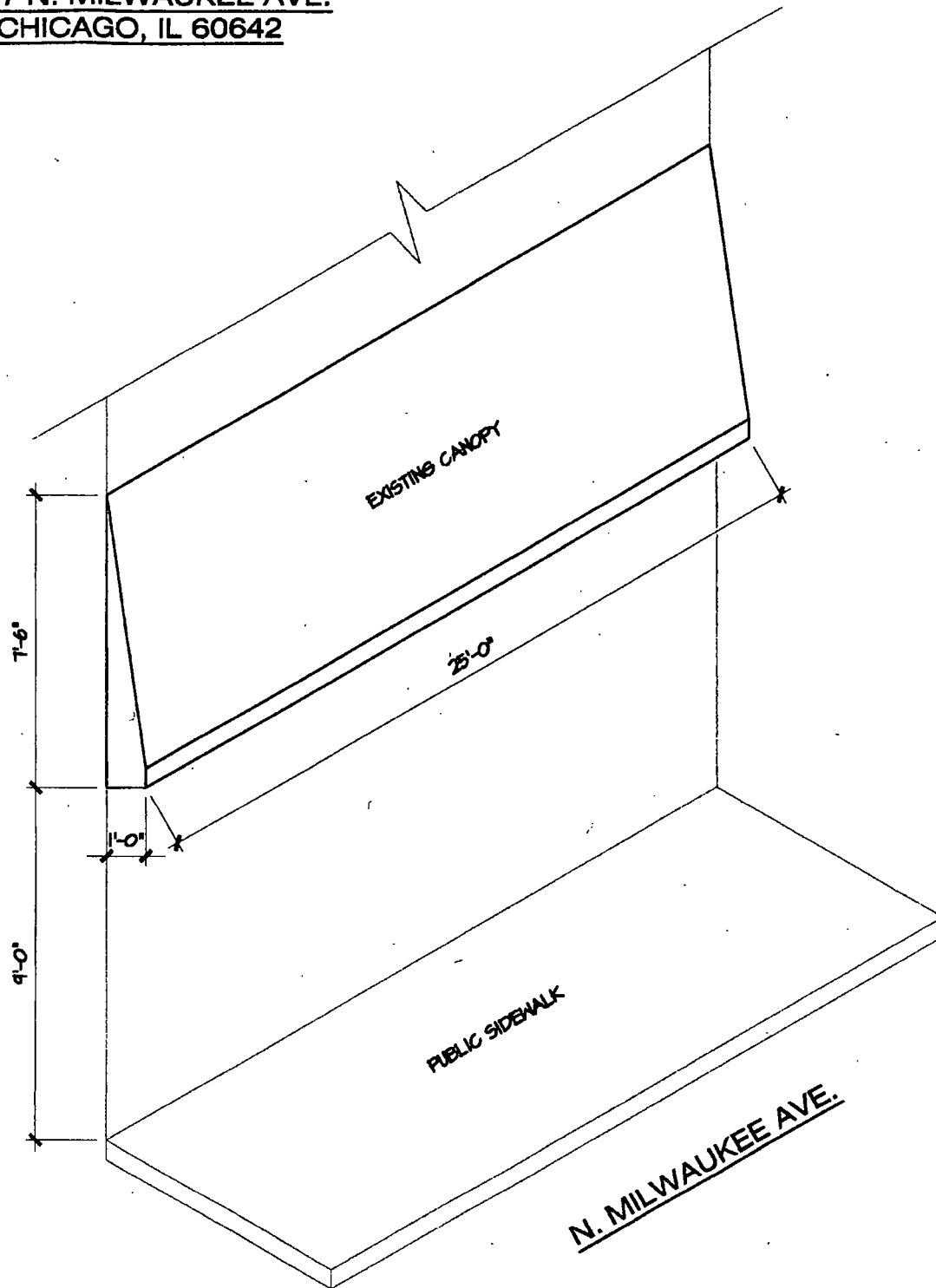

CANOPY SKETCH



05/28/2014

Alderman **Proco Joe Moreno**
Ward # **01**
City of Chicago
City Hall, Room **300**
121 North LaSalle Street
Chicago, Illinois 60602

Re: An ordinance to use and maintain a portion of the public right-of-way for **one (1) canopy(ies)** for **FRINGE A HAIR SALON, INC**, adjacent to the premises known as **1437 N. Milwaukee Ave.**.

Dear Alderman **Proco Joe Moreno**:

The applicant referenced above has requested the use of the public right-of-way for a **canopy(ies)**. An ordinance has been prepared by the Department of Business Affairs and Consumer Protection – Small Business Center - Public Way Use Unit for presentation to the City Council. Because this request was made for properties located in your ward, as approved by you as per the attached, I respectfully request that you introduce the attached ordinance at the next City Council meeting.

If you have any questions regarding this ordinance, please contact Anthony Bertuca at (312) 744-5506.

Department of Business Affairs and Consumer Protection



City of Chicago



O2014-4527

Office of the City Clerk

Document Tracking Sheet

| | |
|---------------------------------|--|
| Meeting Date: | 5/28/2014 |
| Sponsor(s): | Moreno (1) |
| Type: | Ordinance |
| Title: | Canopy(s) for Lubinski Furniture Sale |
| Committee(s) Assignment: | Committee on Transportation and Public Way |

ORDINANCE
LUBINSKI FURNITURE SALE
Acct. No. 50520 - 1
Permit No. 1113009

Be It Ordained by the City Council of the City of Chicago:

SECTION 1. Permission and authority are hereby given and granted to LUBINSKI FURNITURE SALE, upon the terms and subject to the conditions of this ordinance to maintain and use, as now constructed, one (1) Canopy(s) projecting over the public right-of-way adjacent to its premises known as 1550 N. Milwaukee Ave..

Said Canopy(s) at N MILWAUKEE AVE measure(s):

One (1) at one hundred fifteen (115) feet in length, and two point six seven (2.67) feet in width for a total of three hundred seven point zero five (307.05) square feet.

The location of said privilege shall be as shown on prints kept on file with the Department of Business Affairs and Consumer Protection and the Office of the City Clerk.

Said privilege shall be constructed in accordance with plans and specifications approved by the Zoning Department - Signs.

This grant of privilege in the public way shall be subject to the provisions of Section 10-28-015 and all other required provisions of the Municipal Code of Chicago.

The grantee shall pay to the City of Chicago as compensation for the privilege #1113009 herein granted the sum of one hundred forty (\$140.00) per annum in advance.

A 25% penalty will be added for payments received after due date.

The permit holder agrees to hold the City of Chicago harmless for any damage, relocation or replacement costs associated with damage, relocation or removal of private property caused by the City performing work in the public way.

Authority herein given and granted for a period of five (5) years from and after 04/22/2014.

Alderman _____ 

Proco Joe Moreno 1st Ward

CANOPY DIMENSIONS.

1550 N. MILWAUKEE AVE.

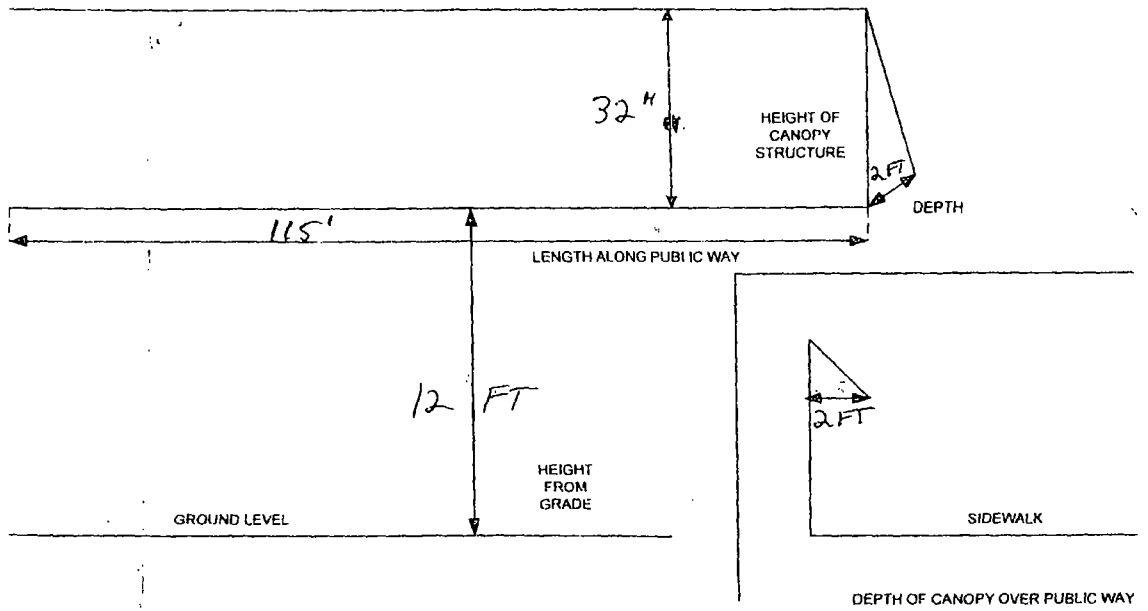



05/28/2014

Alderman **Proco Joe Moreno**
Ward # **01**
City of Chicago
City Hall, Room **300**
121 North LaSalle Street
Chicago, Illinois 60602

Re: An ordinance to use and maintain a portion of the public right-of-way for **one (1) canopy(ies)** for **LUBINSKI FURNITURE SALE**, adjacent to the premises known as **1550 N. Milwaukee Ave.**.

Dear Alderman **Proco Joe Moreno**:

The applicant referenced above has requested the use of the public right-of-way for a **canopy(ies)**. An ordinance has been prepared by the Department of Business Affairs and Consumer Protection – Small Business Center - Public Way Use Unit for presentation to the City Council. Because this request was made for properties located in your ward, as approved by you as per the attached, I respectfully request that you introduce the attached ordinance at the next City Council meeting.

If you have any questions regarding this ordinance, please contact Anthony Bertuca at (312) 744-5506.

Department of Business Affairs and Consumer Protection



City of Chicago



O2014-4529

Office of the City Clerk

Document Tracking Sheet

| | |
|---------------------------------|--|
| Meeting Date: | 5/28/2014 |
| Sponsor(s): | Fioretti (2) |
| Type: | Ordinance |
| Title: | Canopy(s) for Wabash/Roosevelt LLC |
| Committee(s) Assignment: | Committee on Transportation and Public Way |

ORDINANCE
WABASH / ROOSEVELT, LLC
Acct. No. 341926 - 1
Permit No. 1113090

Be It Ordained by the City Council of the City of Chicago:

SECTION 1. Permission and authority are hereby given and granted to WABASH / ROOSEVELT, LLC, upon the terms and subject to the conditions of this ordinance to maintain and use, as now constructed, one (1) Canopy(s) projecting over the public right-of-way adjacent to its premises known as 1147 S. Wabash Ave..

Said Canopy(s) at S WABASH AVE measure(s):

One (1) at fourteen point one seven (14.17) feet in length, and three point seven five (3.75) feet in width for a total of fifty-three point one four (53.14) square feet.

The location of said privilege shall be as shown on prints kept on file with the Department of Business Affairs and Consumer Protection and the Office of the City Clerk.

Said privilege shall be constructed in accordance with plans and specifications approved by the Zoning Department - Signs.

This grant of privilege in the public way shall be subject to the provisions of Section 10-28-015 and all other required provisions of the Municipal Code of Chicago.

The grantee shall pay to the City of Chicago as compensation for the privilege #1113090 herein granted the sum of fifty (\$50.00) per annum in advance.

A 25% penalty will be added for payments received after due date.

The permit holder agrees to hold the City of Chicago harmless for any damage, relocation or replacement costs associated with damage, relocation or removal of private property caused by the City performing work in the public way.

Authority herein given and granted for a period of five (5) years from and after 05/13/2014.

Alderman



Bob Floretti 2nd Ward

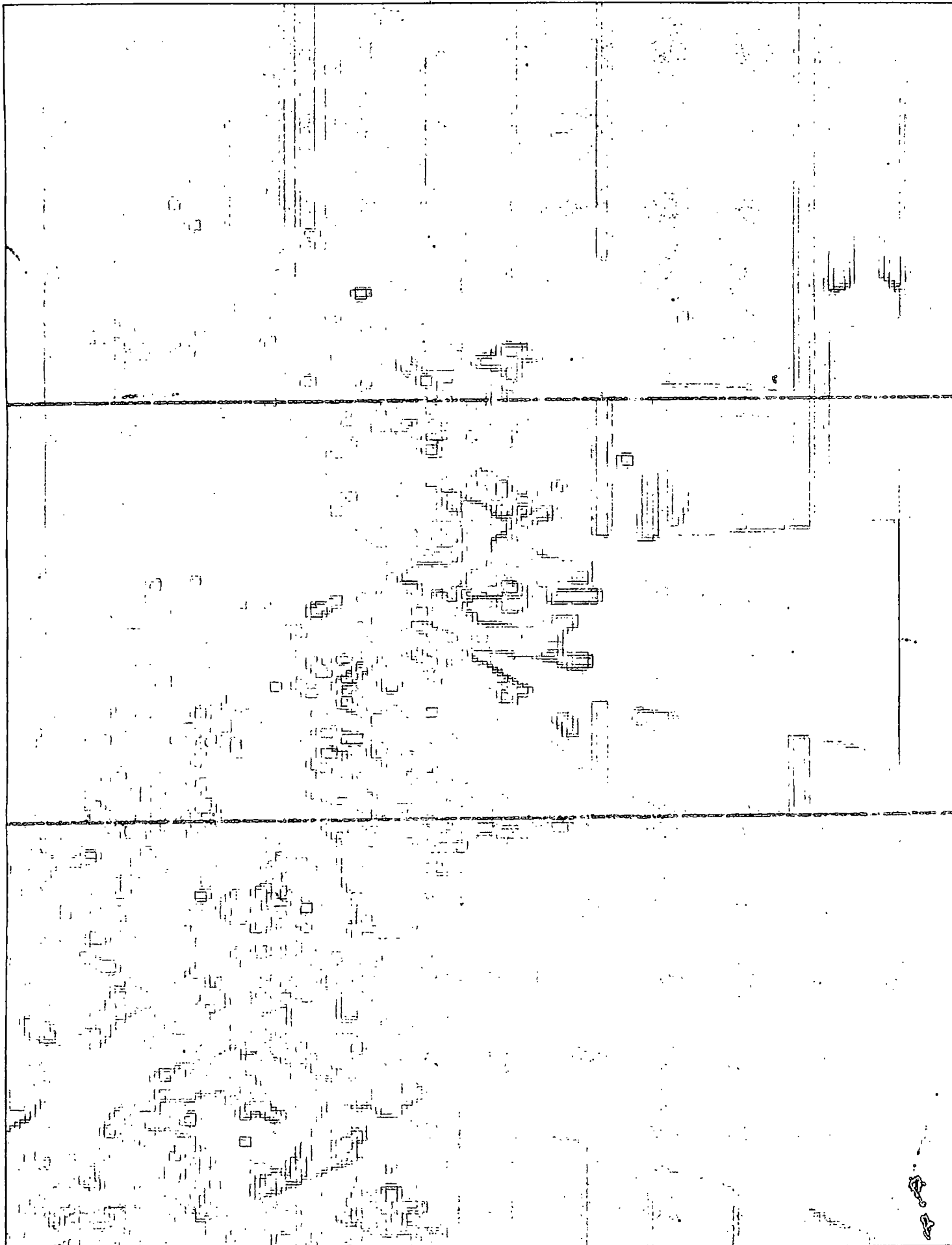



05/28/2014

Alderman **Bob Fioretti**
Ward # **02**
City of Chicago
City Hall, Room **300**
121 North LaSalle Street
Chicago, Illinois 60602

Re: An ordinance to use and maintain a portion of the public right-of-way for **one (1) canopy(ies)** for **WABASH / ROOSEVELT, LLC**, adjacent to the premises known as **1147 S. Wabash Ave.**.

Dear Alderman **Bob Fioretti**:

The applicant referenced above has requested the use of the public right-of-way for a **canopy(ies)**. An ordinance has been prepared by the Department of Business Affairs and Consumer Protection – Small Business Center - Public Way Use Unit for presentation to the City Council. Because this request was made for properties located in your ward, as approved by you as per the attached, I respectfully request that you introduce the attached ordinance at the next City Council meeting.

If you have any questions regarding this ordinance, please contact Anthony Bertuca at (312) 744-5506.

Department of Business Affairs and Consumer Protection



City of Chicago



O2014-4531

Office of the City Clerk

Document Tracking Sheet

| | |
|---------------------------------|--|
| Meeting Date: | 5/28/2014 |
| Sponsor(s): | Fioretti (2) |
| Type: | Ordinance |
| Title: | Canopy(s) for 233 S Wacker LLC |
| Committee(s) Assignment: | Committee on Transportation and Public Way |

ORDINANCE
233 S WACKER LLC
Acct. No. 286120 - 1
Permit No. 1113012

Be It Ordained by the City Council of the City of Chicago:

SECTION 1. Permission and authority are hereby given and granted to 233 S WACKER LLC, upon the terms and subject to the conditions of this ordinance to maintain and use, as now constructed, one (1) Canopy(s) projecting over the public right-of-way adjacent to its premises known as 233 S. Wacker Dr..

Said Canopy(s) at S. Franklin measure(s):

One (1) at one hundred forty (140) feet in length, and thirty-six (36) feet in width for a total of five thousand forty (5040) square feet.

The location of said privilege shall be as shown on prints kept on file with the Department of Business Affairs and Consumer Protection and the Office of the City Clerk.

Said privilege shall be constructed in accordance with plans and specifications approved by the Zoning Department - Signs.

This grant of privilege in the public way shall be subject to the provisions of Section 10-28-015 and all other required provisions of the Municipal Code of Chicago.

The grantee shall pay to the City of Chicago as compensation for the privilege #1113012 herein granted the sum of one hundred sixty-five (\$165.00) per annum in advance.

A 25% penalty will be added for payments received after due date.

The permit holder agrees to hold the City of Chicago harmless for any damage, relocation or replacement costs associated with damage, relocation or removal of private property caused by the City performing work in the public way.

Authority herein given and granted for a period of five (5) years from and after 03/18/2014.

Alderman _____

Bob Fioretti 2nd Ward

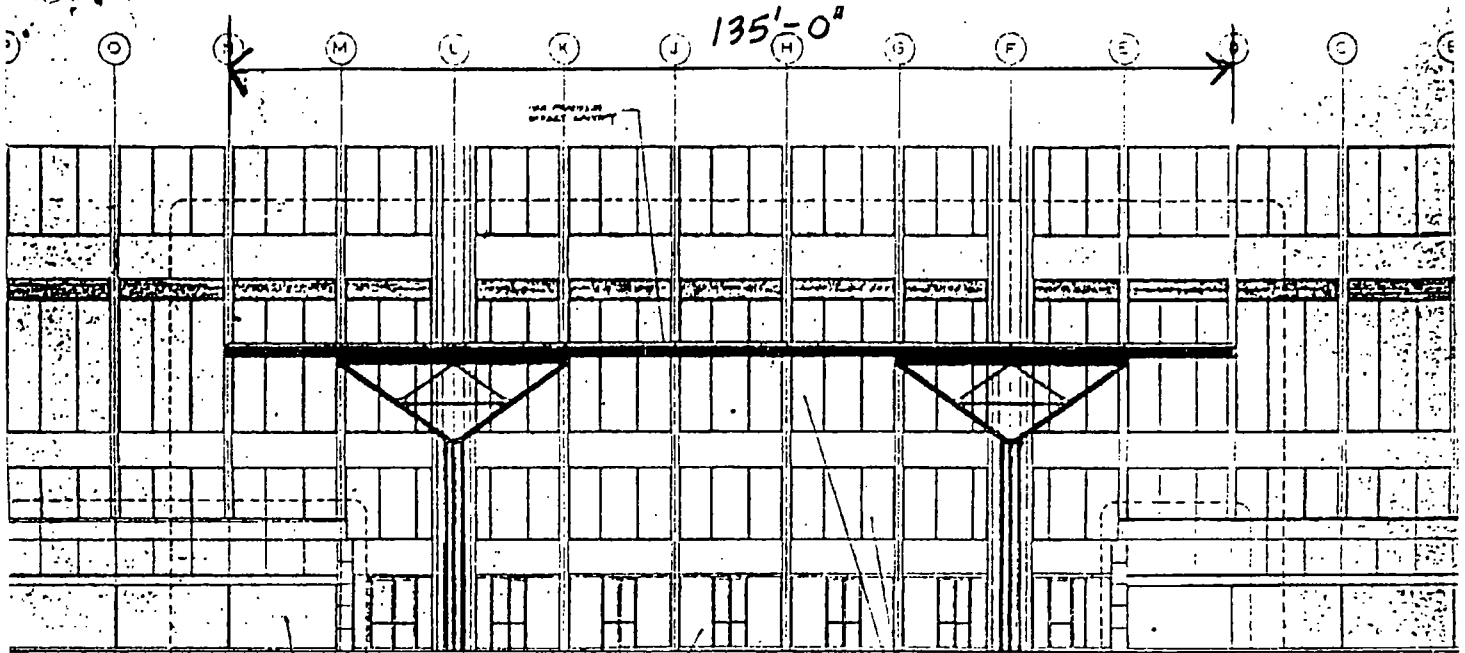

WEST ELEVATION FRANKLIN STREET CANOPY

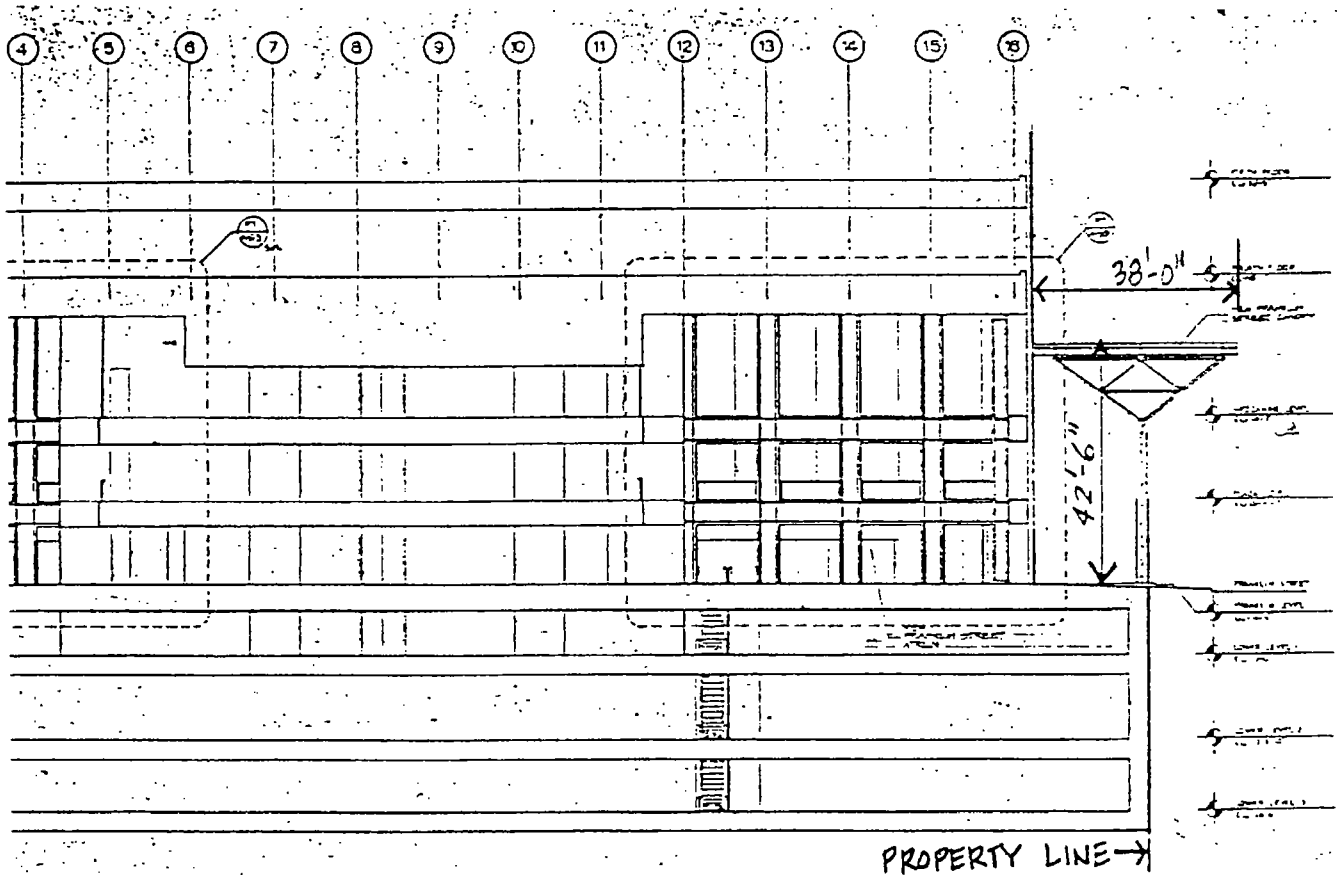

NORTH SECTION FRANKLIN STREET CANOPY



05/28/2014

Alderman **Bob Fioretti**
Ward # **02**
City of Chicago
City Hall, Room **300**
121 North LaSalle Street
Chicago, Illinois 60602

Re: An ordinance to use and maintain a portion of the public right-of-way for **one (1) canopy(ies)** for **233 S WACKER LLC**, adjacent to the premises known as **233 S. Wacker Dr.**.

Dear Alderman **Bob Fioretti**:

The applicant referenced above has requested the use of the public right-of-way for a **canopy(ies)**. An ordinance has been prepared by the Department of Business Affairs and Consumer Protection – Small Business Center - Public Way Use Unit for presentation to the City Council. Because this request was made for properties located in your ward, as approved by you as per the attached, I respectfully request that you introduce the attached ordinance at the next City Council meeting.

If you have any questions regarding this ordinance, please contact Anthony Bertuca at (312) 744-5506.

Department of Business Affairs and Consumer Protection



City of Chicago



O2014-4536

Office of the City Clerk

Document Tracking Sheet

| | |
|---------------------------------|--|
| Meeting Date: | 5/28/2014 |
| Sponsor(s): | Dowell (3) |
| Type: | Ordinance |
| Title: | Canopy(s) for Lakeside Bank |
| Committee(s) Assignment: | Committee on Transportation and Public Way |

ORDINANCE
LAKESIDE BANK
Acct. No. 85333 - 10
Permit No. 1112866

Be It Ordained by the City Council of the City of Chicago:

SECTION 1. Permission and authority are hereby given and granted to LAKESIDE BANK, upon the terms and subject to the conditions of this ordinance to construct, install, maintain and use one (1) Canopy(s) projecting over the public right-of-way adjacent to its premises known as 1350 S. Michigan Ave..

Said Canopy(s) at Michigan measure(s):

One (1) at fourteen point eight three (14.83) feet in length, and five (5) feet in width for a total of seventy-four point one five (74.15) square feet.

The location of said privilege shall be as shown on prints kept on file with the Department of Business Affairs and Consumer Protection and the Office of the City Clerk.

Said privilege shall be constructed in accordance with plans and specifications approved by the Zoning Department - Signs.

This grant of privilege in the public way shall be subject to the provisions of Section 10-28-015 and all other required provisions of the Municipal Code of Chicago.

The grantee shall pay to the City of Chicago as compensation for the privilege #1112866 herein granted the sum of fifty (\$50.00) per annum in advance.

A 25% penalty will be added for payments received after due date.

The permit holder agrees to hold the City of Chicago harmless for any damage, relocation or replacement costs associated with damage, relocation or removal of private property caused by the City performing work in the public way.

Authority herein given and granted for a period of five (5) years from and after Date of Passage.

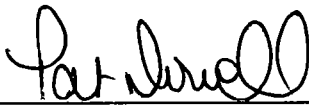
Alderman  _____

Pat Dowell 3rd Ward

Lakeside Bank
 1350 S Michigan Ave
 Chicago IL

Plan and Elevation of
 Canopy over Public Way
 Scale 1" = 20, 31/2" = 1'-0"

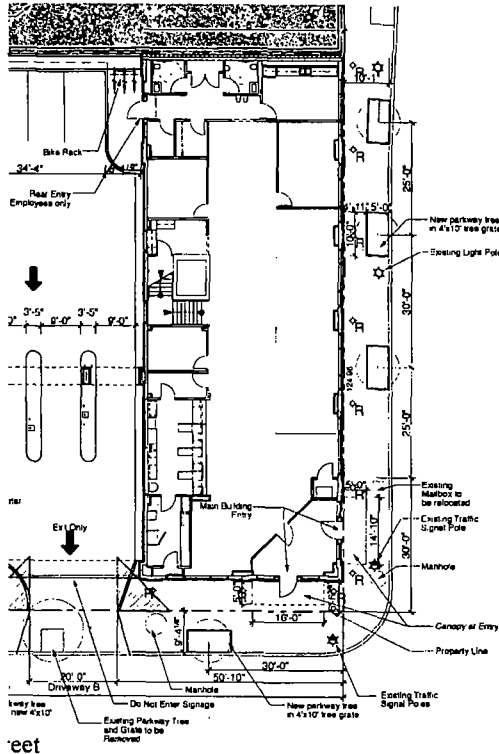

Partial Site Plan

South Michigan Avenue
 90 ft ROW
 Two-way traffic

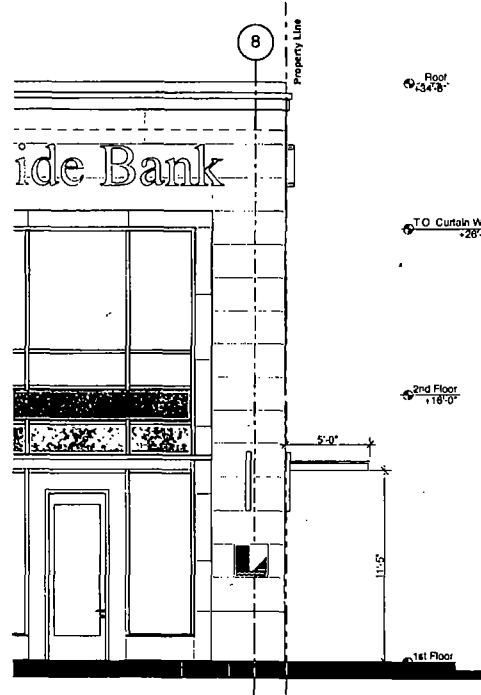

Partial Elevation

Lakeside Bank
 Lakeside Bank LLC
 44-4444
 PAPERBROGG
 HAY 015
 paperbroggpartners
 www.paperbroggpartners.com
 4/20/14
 P11 # 032227



05/28/2014

Alderman **Pat Dowell**
Ward # **03**
City of Chicago
City Hall, Room **300**
121 North LaSalle Street
Chicago, Illinois 60602

Re: An ordinance to use and maintain a portion of the public right-of-way for **one (1) canopy(ies)** for **LAKESIDE BANK**, adjacent to the premises known as **1350 S. Michigan Ave.**.

Dear Alderman **Pat Dowell**:

The applicant referenced above has requested the use of the public right-of-way for a **canopy(ies)**. An ordinance has been prepared by the Department of Business Affairs and Consumer Protection – Small Business Center - Public Way Use Unit for presentation to the City Council. Because this request was made for properties located in your ward, as approved by you as per the attached, I respectfully request that you introduce the attached ordinance at the next City Council meeting.

If you have any questions regarding this ordinance, please contact Anthony Bertuca at (312) 744-5506.

Department of Business Affairs and Consumer Protection



City of Chicago



O2014-4540

Office of the City Clerk

Document Tracking Sheet

| | |
|---------------------------------|--|
| Meeting Date: | 5/28/2014 |
| Sponsor(s): | Sawyer (6) |
| Type: | Ordinance |
| Title: | Canopy(s) for Big City Fashions |
| Committee(s) Assignment: | Committee on Transportation and Public Way |

ORDINANCE
BIG CITY FASHIONS
Acct. No. 358784 - 1
Permit No. 1113001

Be It Ordained by the City Council of the City of Chicago:

SECTION 1. Permission and authority are hereby given and granted to BIG CITY FASHIONS, upon the terms and subject to the conditions of this ordinance to maintain and use, as now constructed, one (1) Canopy(s) projecting over the public right-of-way adjacent to its premises known as 7456 S. Cottage Grove Ave..

Said Canopy(s) at S. Cottage Grove measure(s):

One (1) at seventeen point five (17.5) feet in length, and two (2) feet in width for a total of thirty-five (35) square feet.

The location of said privilege shall be as shown on prints kept on file with the Department of Business Affairs and Consumer Protection and the Office of the City Clerk.

Said privilege shall be constructed in accordance with plans and specifications approved by the Zoning Department - Signs.

This grant of privilege in the public way shall be subject to the provisions of Section 10-28-015 and all other required provisions of the Municipal Code of Chicago.

The grantee shall pay to the City of Chicago as compensation for the privilege #1113001 herein granted the sum of fifty (\$50.00) per annum in advance.

A 25% penalty will be added for payments received after due date.

The permit holder agrees to hold the City of Chicago harmless for any damage, relocation or replacement costs associated with damage, relocation or removal of private property caused by the City performing work in the public way.

Authority herein given and granted for a period of five (5) years from and after 05/14/2013.

Alderman 
Roderick T. Sawyer 6th Ward





05/28/2014

Alderman **Roderick T. Sawyer**
Ward # 06
City of Chicago
City Hall, Room 300
121 North LaSalle Street
Chicago, Illinois 60602

Re: An ordinance to use and maintain a portion of the public right-of-way for **one (1) canopy(ies)** for **BIG CITY FASHIONS**, adjacent to the premises known as **7456 S. Cottage Grove Ave.**.

Dear Alderman **Roderick T. Sawyer**:

The applicant referenced above has requested the use of the public right-of-way for a **canopy(ies)**. An ordinance has been prepared by the Department of Business Affairs and Consumer Protection – Small Business Center - Public Way Use Unit for presentation to the City Council. Because this request was made for properties located in your ward, as approved by you as per the attached, I respectfully request that you introduce the attached ordinance at the next City Council meeting.

If you have any questions regarding this ordinance, please contact Anthony Bertuca at (312) 744-5506.

Department of Business Affairs and Consumer Protection



City of Chicago



O2014-4557

Office of the City Clerk

Document Tracking Sheet

| | |
|---------------------------------|--|
| Meeting Date: | 5/28/2014 |
| Sponsor(s): | Pope (10) |
| Type: | Ordinance |
| Title: | Canopy(s) for Catholic Charities of Chicago, The |
| Committee(s) Assignment: | Committee on Transportation and Public Way |

ORDINANCE
THE CATHOLIC CHARTIES OF CHICAGO
Acct. No. 87875 - 2
Permit No. 1112981

Be It Ordained by the City Council of the City of Chicago:

SECTION 1. Permission and authority are hereby given and granted to THE CATHOLIC CHARTIES OF CHICAGO, upon the terms and subject to the conditions of this ordinance to maintain and use, as now constructed, three (3) Canopy(s) projecting over the public right-of-way adjacent to its premises known as 8959 S. Commercial Ave..

Said Canopy(s) at S. Commerical Avenue measure(s):

One (1) at twenty-five (25) feet in length, and two (2) feet in width for a total of fifty (50) square feet.

One (1) at twenty-one (21) feet in length, and two (2) feet in width for a total of forty-two (42) square feet.

One (1) at fifteen (15) feet in length, and two (2) feet in width for a total of thirty (30) square feet.

The location of said privilege shall be as shown on prints kept on file with the Department of Business Affairs and Consumer Protection and the Office of the City Clerk.

Said privilege shall be constructed in accordance with plans and specifications approved by the Zoning Department - Signs.

This grant of privilege in the public way shall be subject to the provisions of Section 10-28-015 and all other required provisions of the Municipal Code of Chicago.

The grantee shall pay to the City of Chicago as compensation for the privilege #1112981 herein granted the sum of one hundred fifty (\$150.00) per annum in advance.

A 25% penalty will be added for payments received after due date.

The permit holder agrees to hold the City of Chicago harmless for any damage, relocation or replacement costs associated with damage, relocation or removal of private property caused by the City performing work in the public way.

Authority herein given and granted for a period of five (5) years from and after 05/09/2010.

Alderman _____

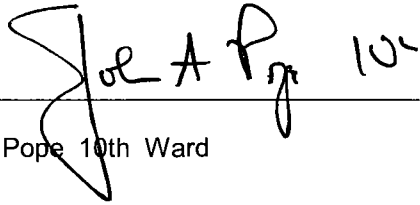
 10th
John Pope 10th Ward

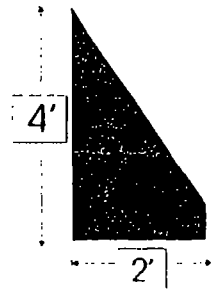
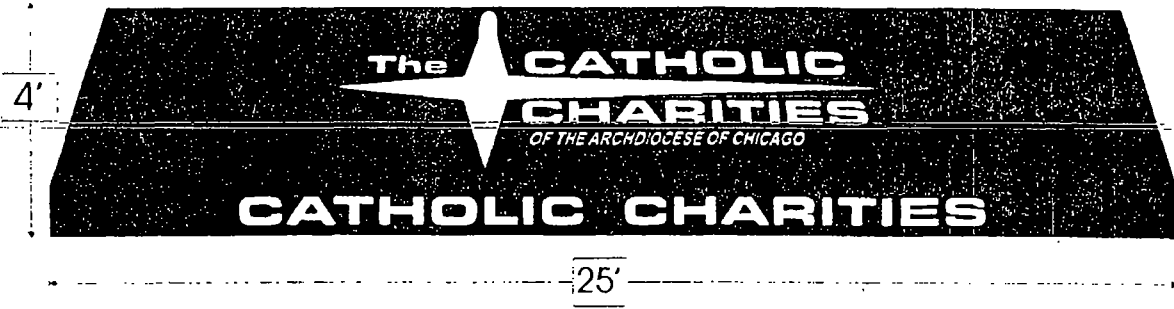



05/28/2014

Alderman **John Pope**
Ward # 10
City of Chicago
City Hall, Room 300
121 North LaSalle Street
Chicago, Illinois 60602

Re: An ordinance to use and maintain a portion of the public right-of-way for **three (3) canopy(ies)** for **THE CATHOLIC CHARTIES OF CHICAGO**, adjacent to the premises known as **8959 S. Commercial Ave.**.

Dear Alderman **John Pope**:

The applicant referenced above has requested the use of the public right-of-way for a **canopy(ies)**. An ordinance has been prepared by the Department of Business Affairs and Consumer Protection – Small Business Center - Public Way Use Unit for presentation to the City Council. Because this request was made for properties located in your ward, as approved by you as per the attached, I respectfully request that you introduce the attached ordinance at the next City Council meeting.

If you have any questions regarding this ordinance, please contact Anthony Bertuca at (312) 744-5506.

Department of Business Affairs and Consumer Protection



City of Chicago



O2014-4567

Office of the City Clerk

Document Tracking Sheet

| | |
|---------------------------------|--|
| Meeting Date: | 5/28/2014 |
| Sponsor(s): | Thomas (17) |
| Type: | Ordinance |
| Title: | Canopy(s) for Cortez Carter - 7901-7911 S Racine Ave |
| Committee(s) Assignment: | Committee on Transportation and Public Way |

ORDINANCE
CORTEZ CARTER
Acct. No. 335771 - 2
Permit No. 1113102

Be It Ordained by the City Council of the City of Chicago:

SECTION 1. Permission and authority are hereby given and granted to CORTEZ CARTER, upon the terms and subject to the conditions of this ordinance to maintain and use, as now constructed, one (1) Canopy(s) projecting over the public right-of-way adjacent to its premises known as 7901-11 S. Racine Ave..

Said Canopy(s) at S RACINE measure(s):

One (1) at ninety (90) feet in length, and two point five (2.5) feet in width for a total of two hundred twenty-five (225) square feet.

The location of said privilege shall be as shown on prints kept on file with the Department of Business Affairs and Consumer Protection and the Office of the City Clerk.

Said privilege shall be constructed in accordance with plans and specifications approved by the Zoning Department - Signs.

This grant of privilege in the public way shall be subject to the provisions of Section 10-28-015 and all other required provisions of the Municipal Code of Chicago.

The grantee shall pay to the City of Chicago as compensation for the privilege #1113102 herein granted the sum of one hundred fifteen (\$115.00) per annum in advance.

A 25% penalty will be added for payments received after due date.

The permit holder agrees to hold the City of Chicago harmless for any damage, relocation or replacement costs associated with damage, relocation or removal of private property caused by the City performing work in the public way.

Authority herein given and granted for a period of five (5) years from and after 11/05/2013.

Alderman

A handwritten signature in black ink, appearing to read 'Latasha R. Thomas', written over a horizontal line.

Latasha R. Thomas 17th Ward

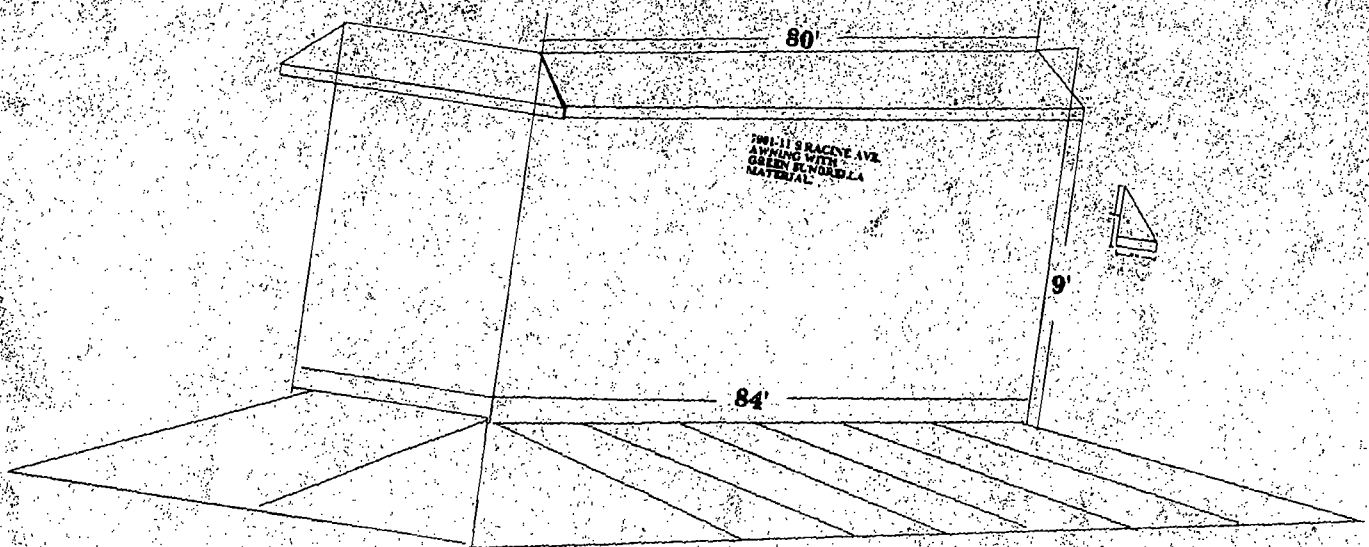



City of Chicago



O2014-4572

Office of the City Clerk

Document Tracking Sheet

| | |
|---------------------------------|---|
| Meeting Date: | 5/28/2014 |
| Sponsor(s): | Thomas (17) |
| Type: | Ordinance |
| Title: | Canopy(s) for Cortez Carter - 1151-1159 W 79th St |
| Committee(s) Assignment: | Committee on Transportation and Public Way |

ORDINANCE
CORTEZ CARTER
Acct. No. 335771 - 1
Permit No. 1113103

Be It Ordained by the City Council of the City of Chicago:

SECTION 1. Permission and authority are hereby given and granted to CORTEZ CARTER, upon the terms and subject to the conditions of this ordinance to maintain and use, as now constructed, one (1) Canopy(s) projecting over the public right-of-way adjacent to its premises known as 1151-59 W. 79th St..

Said Canopy(s) at W 79TH ST measure(s):

One (1) at eighty (80) feet in length, and two point five (2.5) feet in width for a total of two hundred (200) square feet.

The location of said privilege shall be as shown on prints kept on file with the Department of Business Affairs and Consumer Protection and the Office of the City Clerk.

Said privilege shall be constructed in accordance with plans and specifications approved by the Zoning Department - Signs.

This grant of privilege in the public way shall be subject to the provisions of Section 10-28-015 and all other required provisions of the Municipal Code of Chicago.

The grantee shall pay to the City of Chicago as compensation for the privilege #1113103 herein granted the sum of one hundred five (\$105.00) per annum in advance.

A 25% penalty will be added for payments received after due date.

The permit holder agrees to hold the City of Chicago harmless for any damage, relocation or replacement costs associated with damage, relocation or removal of private property caused by the City performing work in the public way.

Authority herein given and granted for a period of five (5) years from and after 11/05/2013.

Alderman _____

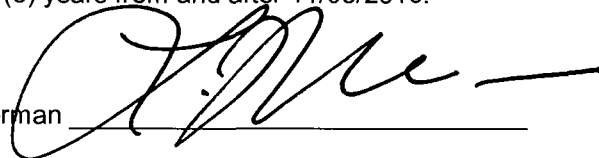

Latasha R. Thomas 17th Ward

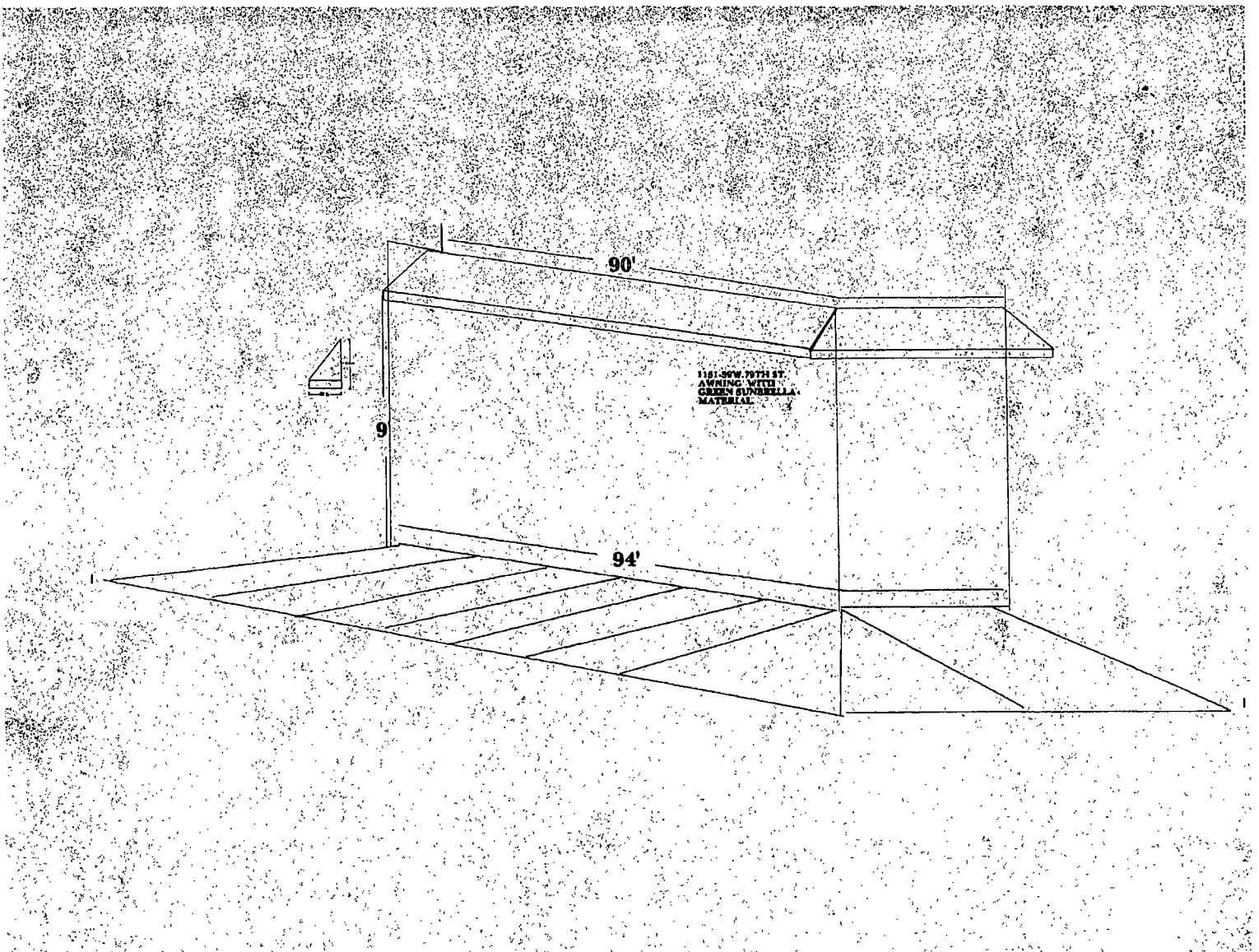



City of Chicago



O2014-4574

Office of the City Clerk

Document Tracking Sheet

| | |
|---------------------------------|--|
| Meeting Date: | 5/28/2014 |
| Sponsor(s): | Maldonado (26) |
| Type: | Ordinance |
| Title: | Canopy(s) for Las Vegas Nite Club, Inc. |
| Committee(s) Assignment: | Committee on Transportation and Public Way |

ORDINANCE
LAS VEGAS NITE CLUB INC
Acct. No. 156 - 1
Permit No. 1112919

Be It Ordained by the City Council of the City of Chicago:

SECTION 1. Permission and authority are hereby given and granted to LAS VEGAS NITE CLUB INC, upon the terms and subject to the conditions of this ordinance to maintain and use, as now constructed, one (1) Canopy(s) projecting over the public right-of-way adjacent to its premises known as 3702 W. Armitage Ave..

Said Canopy(s) at W ARMITAGE AVE measure(s):

One (1) at twenty-five (25) feet in length, and one point two five (1.25) foot in width for a total of thirty-one point two five (31.25) square feet.

The location of said privilege shall be as shown on prints kept on file with the Department of Business Affairs and Consumer Protection and the Office of the City Clerk.

Said privilege shall be constructed in accordance with plans and specifications approved by the Zoning Department - Signs.

This grant of privilege in the public way shall be subject to the provisions of Section 10-28-015 and all other required provisions of the Municipal Code of Chicago.

The grantee shall pay to the City of Chicago as compensation for the privilege #1112919 herein granted the sum of fifty (\$50.00) per annum in advance.

A 25% penalty will be added for payments received after due date.

The permit holder agrees to hold the City of Chicago harmless for any damage, relocation or replacement costs associated with damage, relocation or removal of private property caused by the City performing work in the public way.

Authority herein given and granted for a period of five (5) years from and after 04/22/2014.

Alderman 

Roberto Maldonado 26th Ward





05/28/2014

Alderman **Roberto Maldonado**
Ward # **26**
City of Chicago
City Hall, Room **300**
121 North LaSalle Street
Chicago, Illinois 60602

Re: An ordinance to use and maintain a portion of the public right-of-way for **one (1) canopy(ies)** for **LAS VEGAS NITE CLUB INC**, adjacent to the premises known as **3702 W. Armitage Ave.**.

Dear Alderman **Roberto Maldonado**:

The applicant referenced above has requested the use of the public right-of-way for a **canopy(ies)**. An ordinance has been prepared by the Department of Business Affairs and Consumer Protection – Small Business Center - Public Way Use Unit for presentation to the City Council. Because this request was made for properties located in your ward, as approved by you as per the attached, I respectfully request that you introduce the attached ordinance at the next City Council meeting.

If you have any questions regarding this ordinance, please contact Anthony Bertuca at (312) 744-5506.

Department of Business Affairs and Consumer Protection



City of Chicago



O2014-4579

Office of the City Clerk

Document Tracking Sheet

| | |
|---------------------------------|--|
| Meeting Date: | 5/28/2014 |
| Sponsor(s): | Burnett (27) |
| Type: | Ordinance |
| Title: | Canopy(s) for Greek Islands Restaurant |
| Committee(s) Assignment: | Committee on Transportation and Public Way |

ORDINANCE
GREEK ISLANDS RESTAURANT
Acct. No. 1797 - 1
Permit No. 1113077

Be It Ordained by the City Council of the City of Chicago:

SECTION 1. Permission and authority are hereby given and granted to GREEK ISLANDS RESTAURANT, upon the terms and subject to the conditions of this ordinance to maintain and use, as now constructed, one (1) Canopy(s) projecting over the public right-of-way adjacent to its premises known as 200 S. Halsted St..

Said Canopy(s) at W. Adams Street measure(s):

One (1) at eleven point five (11.5) feet in length, and twelve (12) feet in width for a total of one hundred thirty-eight (138) square feet.

The location of said privilege shall be as shown on prints kept on file with the Department of Business Affairs and Consumer Protection and the Office of the City Clerk.

Said privilege shall be constructed in accordance with plans and specifications approved by the Zoning Department - Signs.

This grant of privilege in the public way shall be subject to the provisions of Section 10-28-015 and all other required provisions of the Municipal Code of Chicago.

The grantee shall pay to the City of Chicago as compensation for the privilege #1113077 herein granted the sum of fifty (\$50.00) per annum in advance.

A 25% penalty will be added for payments received after due date.

The permit holder agrees to hold the City of Chicago harmless for any damage, relocation or replacement costs associated with damage, relocation or removal of private property caused by the City performing work in the public way.

Authority herein given and granted for a period of five (5) years from and after 05/24/2014.

Alderman 
Walter Burnett Jr. 27th Ward

ADAMS STREET

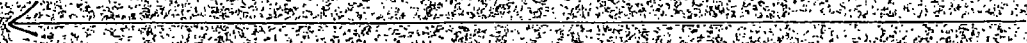

STREET LIGHT



FIRE HYDRANT



7 FT.
9 IN.

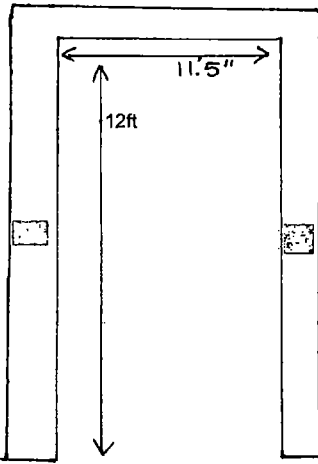

HT. = 8 FEET

GREEK ISLANDS RESTAURANT

ENTRANCE TO RESTAURANT

200 S HALSTED



City of Chicago



O2014-4582

Office of the City Clerk

Document Tracking Sheet

| | |
|---------------------------------|--|
| Meeting Date: | 5/28/2014 |
| Sponsor(s): | Colón (35) |
| Type: | Ordinance |
| Title: | Canopy(s) for El Vigia Restaurant |
| Committee(s) Assignment: | Committee on Transportation and Public Way |

ORDINANCE
EL VIGIA RESTAURANT
Acct. No. 337525 - 1
Permit No. 1113029

Be It Ordained by the City Council of the City of Chicago:

SECTION 1. Permission and authority are hereby given and granted to EL VIGIA RESTAURANT, upon the terms and subject to the conditions of this ordinance to maintain and use, as now constructed, two (2) Canopy(s) projecting over the public right-of-way adjacent to its premises known as 4124 W. Armitage Ave..

Said Canopy(s) at W ARMITAGE AVE measure(s):

One (1) at forty-nine point six seven (49.67) feet in length, and four (4) feet in width for a total of one hundred ninety-eight point six eight (198.68) square feet.

Said Canopy(s) at KEDVALE measure(s):

One (1) at sixty (60) feet in length, and four (4) feet in width for a total of two hundred forty (240) square feet.

The location of said privilege shall be as shown on prints kept on file with the Department of Business Affairs and Consumer Protection and the Office of the City Clerk.

Said privilege shall be constructed in accordance with plans and specifications approved by the Zoning Department - Signs.

This grant of privilege in the public way shall be subject to the provisions of Section 10-28-015 and all other required provisions of the Municipal Code of Chicago.

The grantee shall pay to the City of Chicago as compensation for the privilege #1113029 herein granted the sum of one hundred fifty-nine dollars and sixty-seven cents (\$159.67) per annum in advance.

A 25% penalty will be added for payments received after due date.

The permit holder agrees to hold the City of Chicago harmless for any damage, relocation or replacement costs associated with damage, relocation or removal of private property caused by the City performing work in the public way.

Authority herein given and granted for a period of five (5) years from and after 04/22/2014.

Alderman _____

Reynaldo Colon 35th Ward

4122, W. Armitage
29

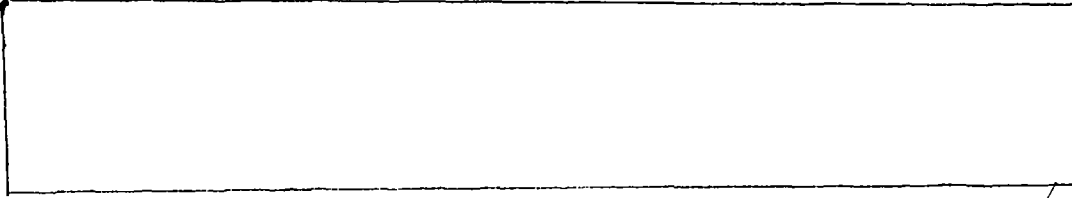

Length 49.67
Width 4 FT
Depth 4 FT
Height above grade 8 FT

~~#~~ Keduale

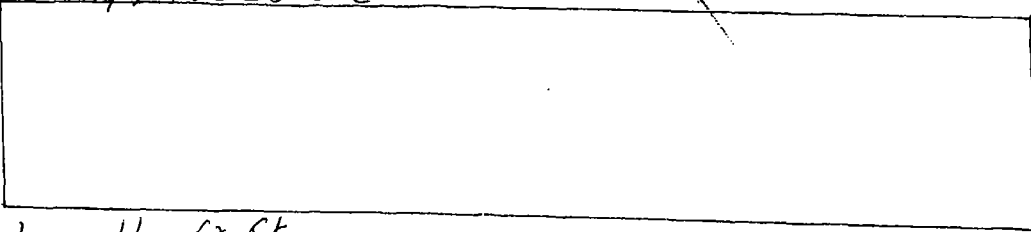

Length 60 FT
Width 4 FT
Depth 4 FT
Height above grade 8 FT



05/28/2014

Alderman Reynaldo Colon
Ward # 35
City of Chicago
City Hall, Room 203
121 North LaSalle Street
Chicago, Illinois 60602

Re: An ordinance to use and maintain a portion of the public right-of-way for **two (2) canopy(ies)** for **EL VIGIA RESTAURANT**, adjacent to the premises known as **4124 W. Armitage Ave.**

Dear Alderman **Reynaldo Colon**:

The applicant referenced above has requested the use of the public right-of-way for a **canopy(ies)**. An ordinance has been prepared by the Department of Business Affairs and Consumer Protection – Small Business Center - Public Way Use Unit for presentation to the City Council. Because this request was made for properties located in your ward, as approved by you as per the attached, I respectfully request that you introduce the attached ordinance at the next City Council meeting.

If you have any questions regarding this ordinance, please contact Anthony Bertuca at (312) 744-5506.

Department of Business Affairs and Consumer Protection



City of Chicago



O2014-4584

Office of the City Clerk

Document Tracking Sheet

| | |
|---------------------------------|--|
| Meeting Date: | 5/28/2014 |
| Sponsor(s): | O'Connor (40) |
| Type: | Ordinance |
| Title: | Canopy(s) for Allied Inventory Co., Inc. |
| Committee(s) Assignment: | Committee on Transportation and Public Way |

ORDINANCE
ALLIED INVENTORY CO.,INC.
Acct. No. 30341 - 1
Permit No. 1113007

Be It Ordained by the City Council of the City of Chicago:

SECTION 1. Permission and authority are hereby given and granted to ALLIED INVENTORY CO.,INC., upon the terms and subject to the conditions of this ordinance to maintain and use, as now constructed, one (1) Canopy(s) projecting over the public right-of-way adjacent to its premises known as 5718 N. Western Ave..

Said Canopy(s) at N. WESTERN AVE. measure(s):

One (1) at nineteen (19) feet in length, and two point eight (2.8) feet in width for a total of fifty-three point two (53.2) square feet.

The location of said privilege shall be as shown on prints kept on file with the Department of Business Affairs and Consumer Protection and the Office of the City Clerk.

Said privilege shall be constructed in accordance with plans and specifications approved by the Zoning Department - Signs.

This grant of privilege in the public way shall be subject to the provisions of Section 10-28-015 and all other required provisions of the Municipal Code of Chicago.

The grantee shall pay to the City of Chicago as compensation for the privilege #1113007 herein granted the sum of fifty (\$50.00) per annum in advance.

A 25% penalty will be added for payments received after due date.

The permit holder agrees to hold the City of Chicago harmless for any damage, relocation or replacement costs associated with damage, relocation or removal of private property caused by the City performing work in the public way.

Authority herein given and granted for a period of five (5) years from and after 04/26/2014.

Alderman 
Patrick O'Connor 40th Ward

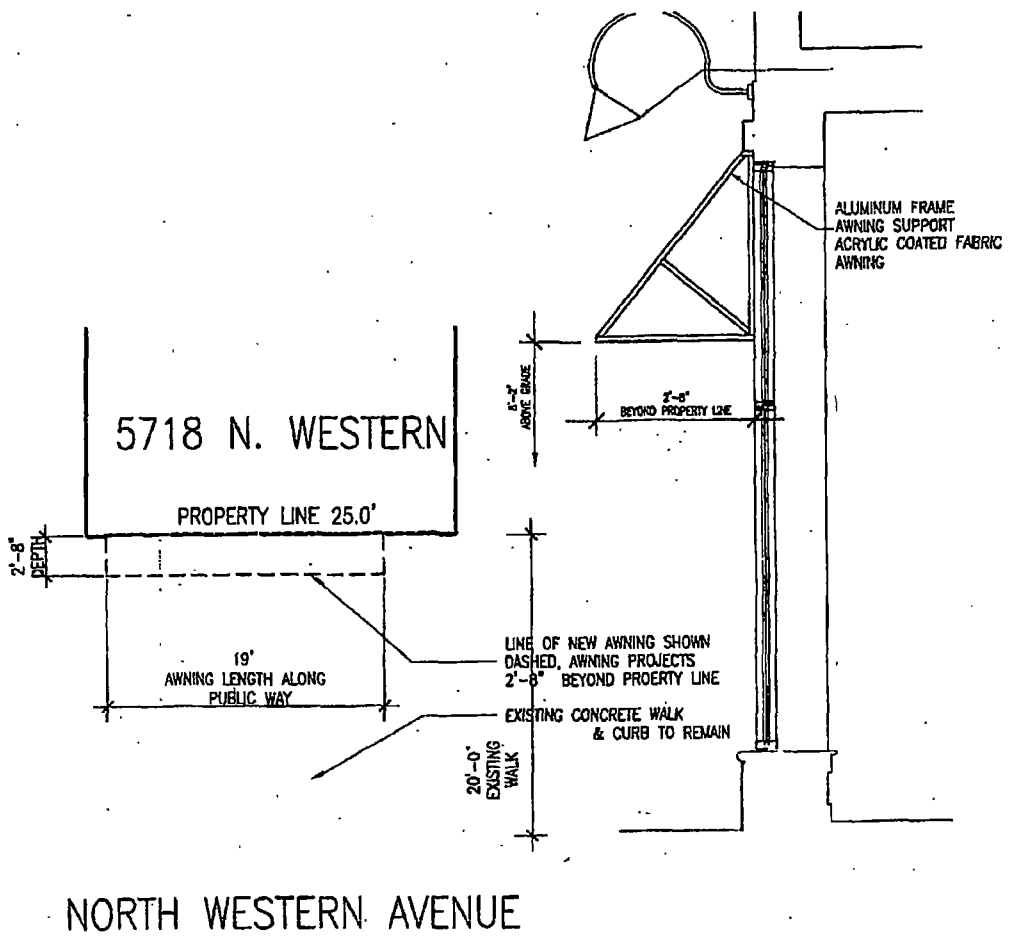

Jan 31 06 05:59p

P.S



05/28/2014

Alderman **Patrick O'Connor**
Ward # **40**
City of Chicago
City Hall, Room **305**
121 North LaSalle Street
Chicago, Illinois 60602

Re: An ordinance to use and maintain a portion of the public right-of-way for **one (1) canopy(ies)** for **ALLIED INVENTORY CO.,INC.**, adjacent to the premises known as **5718 N. Western Ave.**

Dear Alderman **Patrick O'Connor**:

The applicant referenced above has requested the use of the public right-of-way for a **canopy(ies)**. An ordinance has been prepared by the Department of Business Affairs and Consumer Protection – Small Business Center - Public Way Use Unit for presentation to the City Council. Because this request was made for properties located in your ward, as approved by you as per the attached, I respectfully request that you introduce the attached ordinance at the next City Council meeting.

If you have any questions regarding this ordinance, please contact Anthony Bertuca at (312) 744-5506.

Department of Business Affairs and Consumer Protection



City of Chicago



O2014-4592

Office of the City Clerk

Document Tracking Sheet

| | |
|---------------------------------|--|
| Meeting Date: | 5/28/2014 |
| Sponsor(s): | Reilly (42) |
| Type: | Ordinance |
| Title: | Canopy(s) for Hyatt Place |
| Committee(s) Assignment: | Committee on Transportation and Public Way |

ORDINANCE
HYATT PLACE
Acct. No. 389795 - 1
Permit No. 1113082

Be It Ordained by the City Council of the City of Chicago:

SECTION 1. Permission and authority are hereby given and granted to HYATT PLACE, upon the terms and subject to the conditions of this ordinance to construct, install, maintain and use two (2) Canopy(s) projecting over the public right-of-way adjacent to its premises known as 28 N. Franklin St..

Said Canopy(s) at N. Franklin Street measure(s):

One (1) at thirty-one point two five (31.25) feet in length, and eleven point eight three (11.83) feet in width for a total of three hundred sixty-nine point six nine (369.69) square feet.

Said Canopy(s) at W. Calhoun Place measure(s):

One (1) at sixty-four point seven five (64.75) feet in length, and five point one seven (5.17) feet in width for a total of three hundred thirty-four point seven six (334.76) square feet.

The location of said privilege shall be as shown on prints kept on file with the Department of Business Affairs and Consumer Protection and the Office of the City Clerk.

Said privilege shall be constructed in accordance with plans and specifications approved by the Zoning Department - Signs.

This grant of privilege in the public way shall be subject to the provisions of Section 10-28-015 and all other required provisions of the Municipal Code of Chicago.

The grantee shall pay to the City of Chicago as compensation for the privilege #1113082 herein granted the sum of one hundred forty-six (\$146.00) per annum in advance.

A 25% penalty will be added for payments received after due date.

The permit holder agrees to hold the City of Chicago harmless for any damage, relocation or replacement costs associated with damage, relocation or removal of private property caused by the City performing work in the public way.

Authority herein given and granted for a period of five (5) years from and after Date of Passage.

Alderman _____

Brendan Reilly 42nd Ward

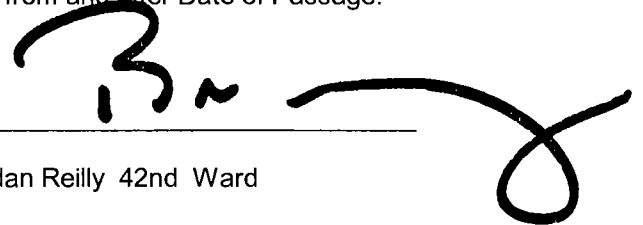
A large, stylized handwritten signature in black ink, appearing to read 'B. Reilly', is written over a horizontal line. The signature is fluid and cursive, with a large loop at the end.

Handwritten scribbles or marks, possibly initials or a signature, located in the lower-left quadrant of the page.

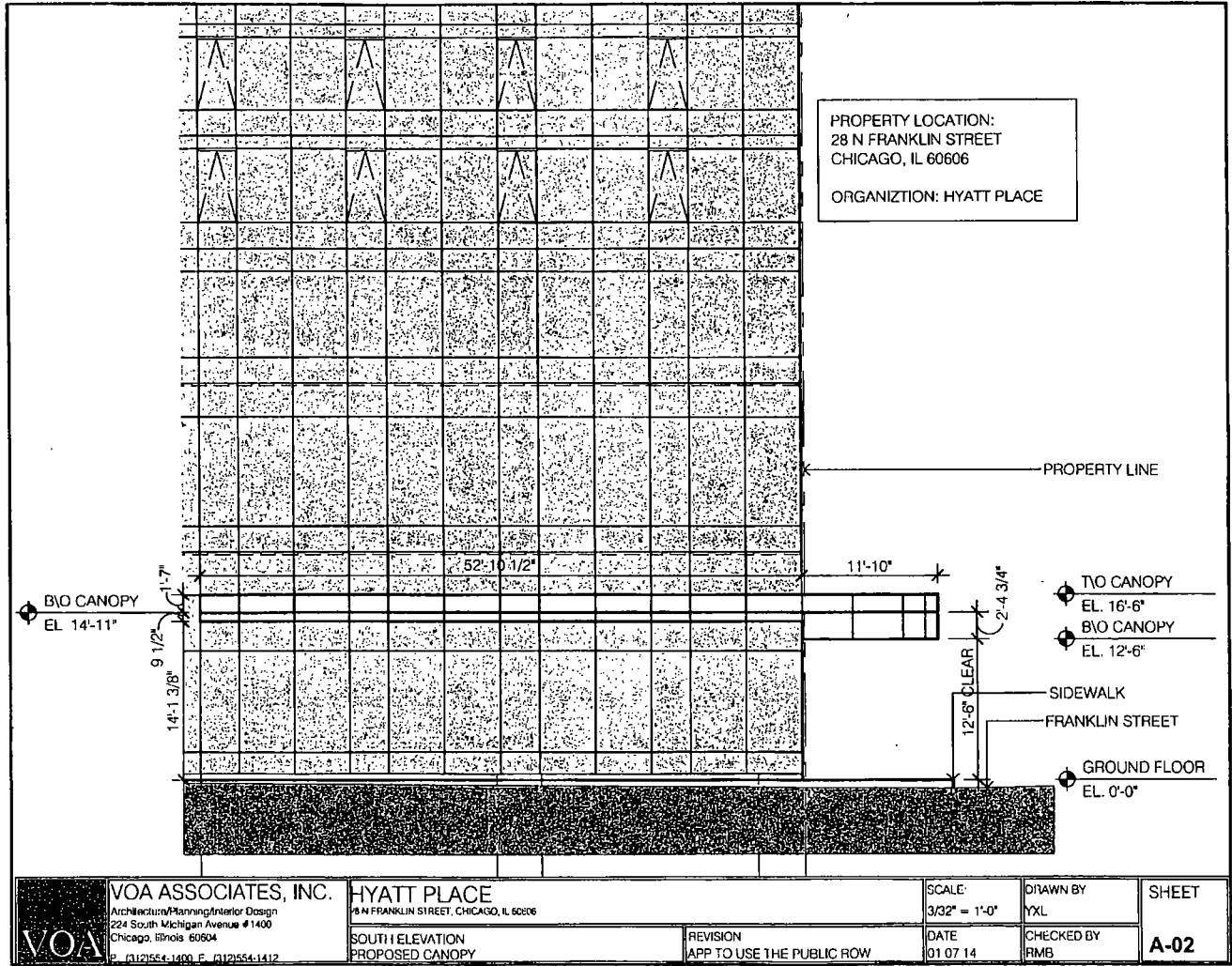



City of Chicago



O2014-4597

Office of the City Clerk

Document Tracking Sheet

| | |
|---------------------------------|--|
| Meeting Date: | 5/28/2014 |
| Sponsor(s): | Reilly (42) |
| Type: | Ordinance |
| Title: | Canopy(s) for James Hotel Chicago |
| Committee(s) Assignment: | Committee on Transportation and Public Way |

ORDINANCE
JAMES HOTEL CHICAGO
Acct. No. 326251 - 1
Permit No. 1112987

Be It Ordained by the City Council of the City of Chicago:

SECTION 1. Permission and authority are hereby given and granted to JAMES HOTEL CHICAGO, upon the terms and subject to the conditions of this ordinance to maintain and use, as now constructed, three (3) Canopy(s) projecting over the public right-of-way adjacent to its premises known as 55 E. Ontario St..

Said Canopy(s) at E. Ontario measure(s):

One (1) at twenty point five (20.5) feet in length, and eight (8) feet in width for a total of one hundred sixty-four (164) square feet.

Said Canopy(s) at N. Rush measure(s):

One (1) at eighteen point three three (18.33) feet in length, and six (6) feet in width for a total of one hundred nine point nine eight (109.98) square feet.

Said Canopy(s) at N. Rush measure(s):

One (1) at fourteen point six six (14.66) feet in length, and six (6) feet in width for a total of eighty-seven point nine six (87.96) square feet.

The location of said privilege shall be as shown on prints kept on file with the Department of Business Affairs and Consumer Protection and the Office of the City Clerk.

Said privilege shall be constructed in accordance with plans and specifications approved by the Zoning Department - Signs.

This grant of privilege in the public way shall be subject to the provisions of Section 10-28-015 and all other required provisions of the Municipal Code of Chicago.

The grantee shall pay to the City of Chicago as compensation for the privilege #1112987 herein granted the sum of one hundred fifty (\$150.00) per annum in advance.

A 25% penalty will be added for payments received after due date.

The permit holder agrees to hold the City of Chicago harmless for any damage, relocation or replacement costs associated with damage, relocation or removal of private property caused by the City performing work in the public way.

Authority herein given and granted for a period of five (5) years from and after 05/13/2014.

Alderman _____

Brendan Reilly 42nd Ward

Handwritten signature or scribble.

APPLICATION TO USE THE PUBLIC RIGHT OF WAY



EXAMPLE OF CANOPY/AWNING DRAWING

JAMES Hotel
- FRONT ENTRANCE. -

CANOPY DRAWING

PROPERTY LOCATION E. ONTARIO STREET

ORGANIZATION(S) NAME: JAMES Hotel

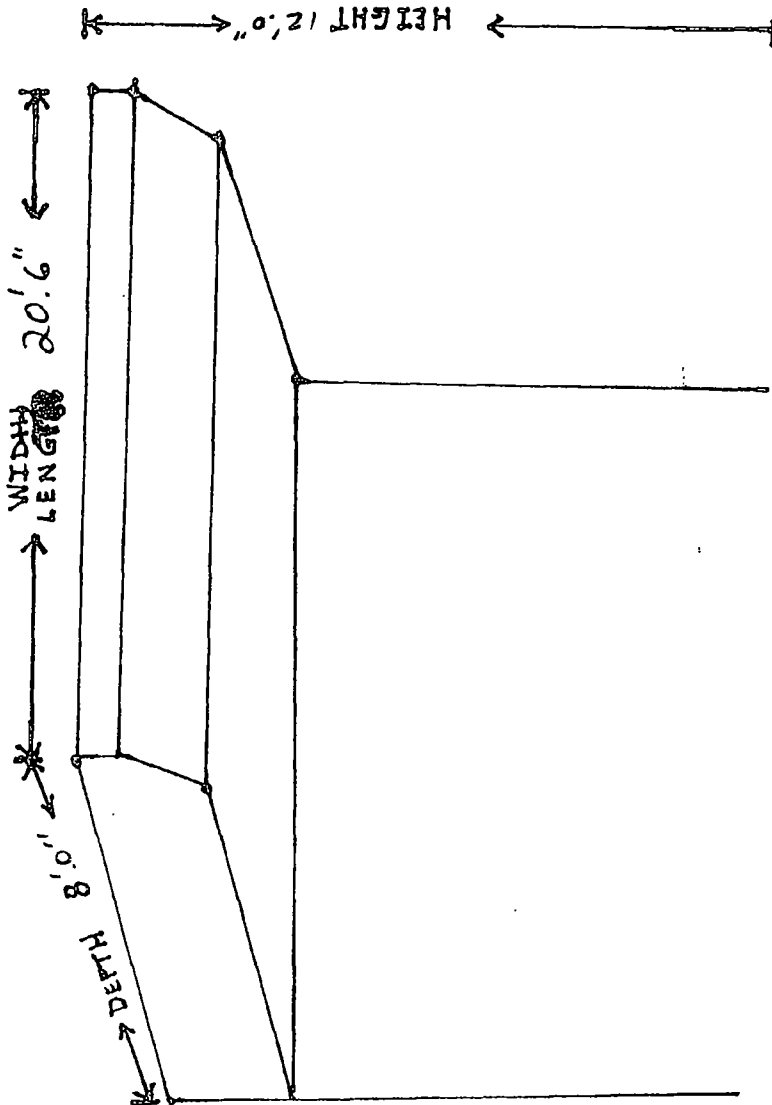



City of Chicago



O2014-4606

Office of the City Clerk

Document Tracking Sheet

| | |
|---------------------------------|--|
| Meeting Date: | 5/28/2014 |
| Sponsor(s): | Reilly (42) |
| Type: | Ordinance |
| Title: | Canopy(s) for Portillo's Hot Dogs, Inc. - Privilege No. 1112895 |
| Committee(s) Assignment: | Committee on Transportation and Public Way |

ORDINANCE
PORTILLO'S HOT DOGS, INC.
Acct. No. 10047 - 1
Permit No. 1112895

Be It Ordained by the City Council of the City of Chicago:

SECTION 1. Permission and authority are hereby given and granted to PORTILLO'S HOT DOGS, INC., upon the terms and subject to the conditions of this ordinance to maintain and use, as now constructed, one (1) Canopy(s) projecting over the public right-of-way adjacent to its premises known as 100 W. Ontario St..

Said Canopy(s) at WEST ONTARIO measure(s):

One (1) at nineteen point four (19.4) feet in length, and four (4) feet in width for a total of seventy-seven point six (77.6) square feet.

The location of said privilege shall be as shown on prints kept on file with the Department of Business Affairs and Consumer Protection and the Office of the City Clerk.

Said privilege shall be constructed in accordance with plans and specifications approved by the Zoning Department - Signs.

This grant of privilege in the public way shall be subject to the provisions of Section 10-28-015 and all other required provisions of the Municipal Code of Chicago.

The grantee shall pay to the City of Chicago as compensation for the privilege #1112895 herein granted the sum of fifty (\$50.00) per annum in advance.

A 25% penalty will be added for payments received after due date.

The permit holder agrees to hold the City of Chicago harmless for any damage, relocation or replacement costs associated with damage, relocation or removal of private property caused by the City performing work in the public way.

Authority herein given and granted for a period of five (5) years from and after 05/24/2014.

Alderman _____

Brendan Reilly 42nd Ward

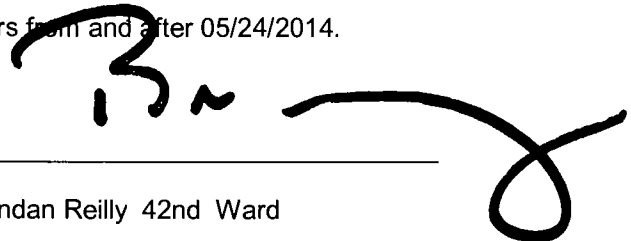
A large, stylized handwritten signature in black ink, appearing to read 'B. Reilly', is written over the signature line and extends to the right.

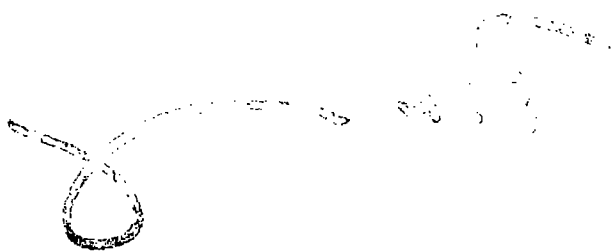

100 W. Ontario

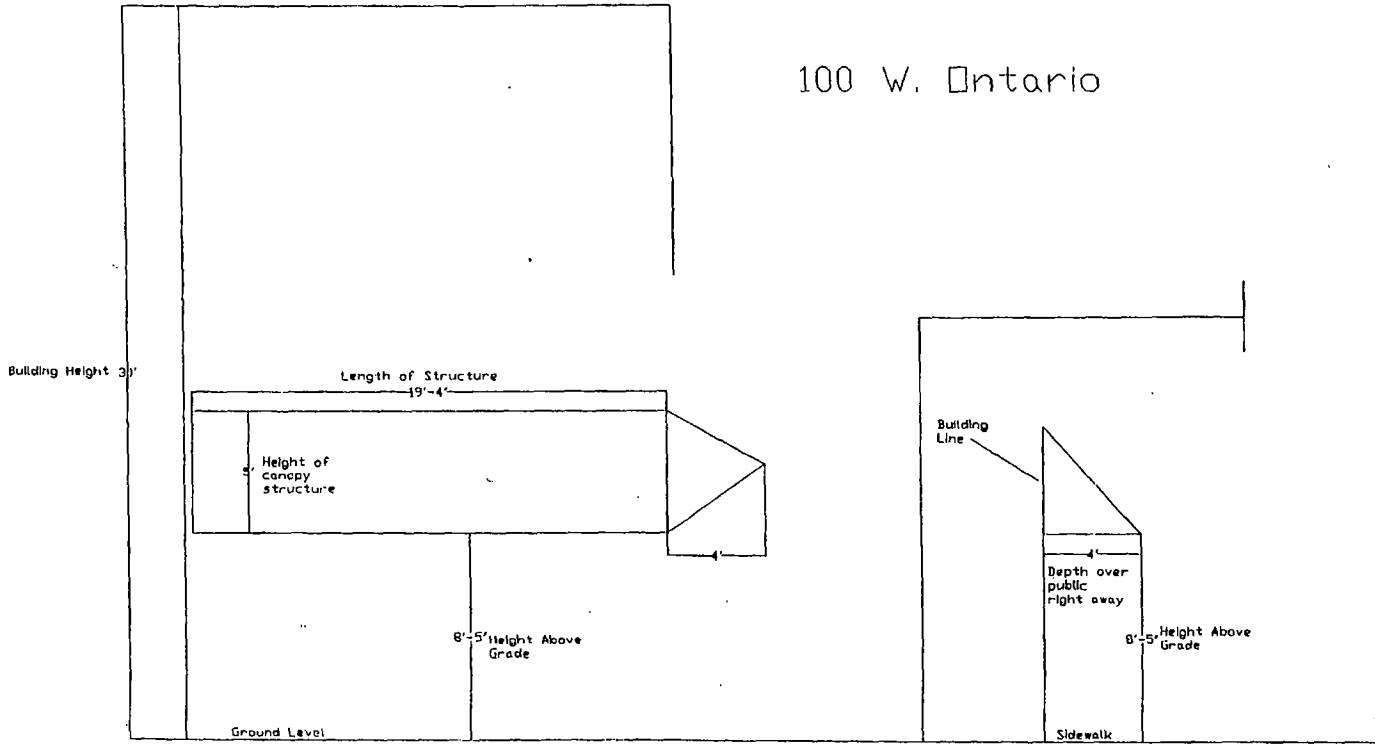



City of Chicago



O2014-4610

Office of the City Clerk

Document Tracking Sheet

| | |
|---------------------------------|--|
| Meeting Date: | 5/28/2014 |
| Sponsor(s): | Reilly (42) |
| Type: | Ordinance |
| Title: | Canopy(s) for Portillo's Hot Dogs, Inc. - Privilege No. 1113072 |
| Committee(s) Assignment: | Committee on Transportation and Public Way |

ORDINANCE
PORTILLO'S HOT DOGS, INC.
Acct. No. 10047 - 1
Permit No. 1113072

Be It Ordained by the City Council of the City of Chicago:

SECTION 1. Permission and authority are hereby given and granted to PORTILLO'S HOT DOGS, INC., upon the terms and subject to the conditions of this ordinance to maintain and use, as now constructed, one (1) Canopy(s) projecting over the public right-of-way adjacent to its premises known as 100 W. Ontario St..

Said Canopy(s) at WEST ONTARIO measure(s):

One (1) at nineteen point four (19.4) feet in length, and four (4) feet in width for a total of seventy-seven point six (77.6) square feet.

The location of said privilege shall be as shown on prints kept on file with the Department of Business Affairs and Consumer Protection and the Office of the City Clerk.

Said privilege shall be constructed in accordance with plans and specifications approved by the Zoning Department - Signs.

This grant of privilege in the public way shall be subject to the provisions of Section 10-28-015 and all other required provisions of the Municipal Code of Chicago.

The grantee shall pay to the City of Chicago as compensation for the privilege #1113072 herein granted the sum of fifty (\$50.00) per annum in advance.

A 25% penalty will be added for payments received after due date.

The permit holder agrees to hold the City of Chicago harmless for any damage, relocation or replacement costs associated with damage, relocation or removal of private property caused by the City performing work in the public way.

Authority herein given and granted for a period of five (5) years from and after 05/24/2019.

Alderman _____

Brendan Reilly 42nd Ward

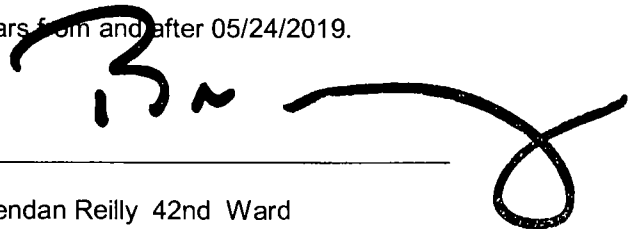
A large, stylized handwritten signature in black ink, appearing to read 'B. Reilly', is written over the signature line and extends to the right.

Handwritten text, possibly a signature or name, located in the lower-left quadrant of the page.

100 W. Ontario

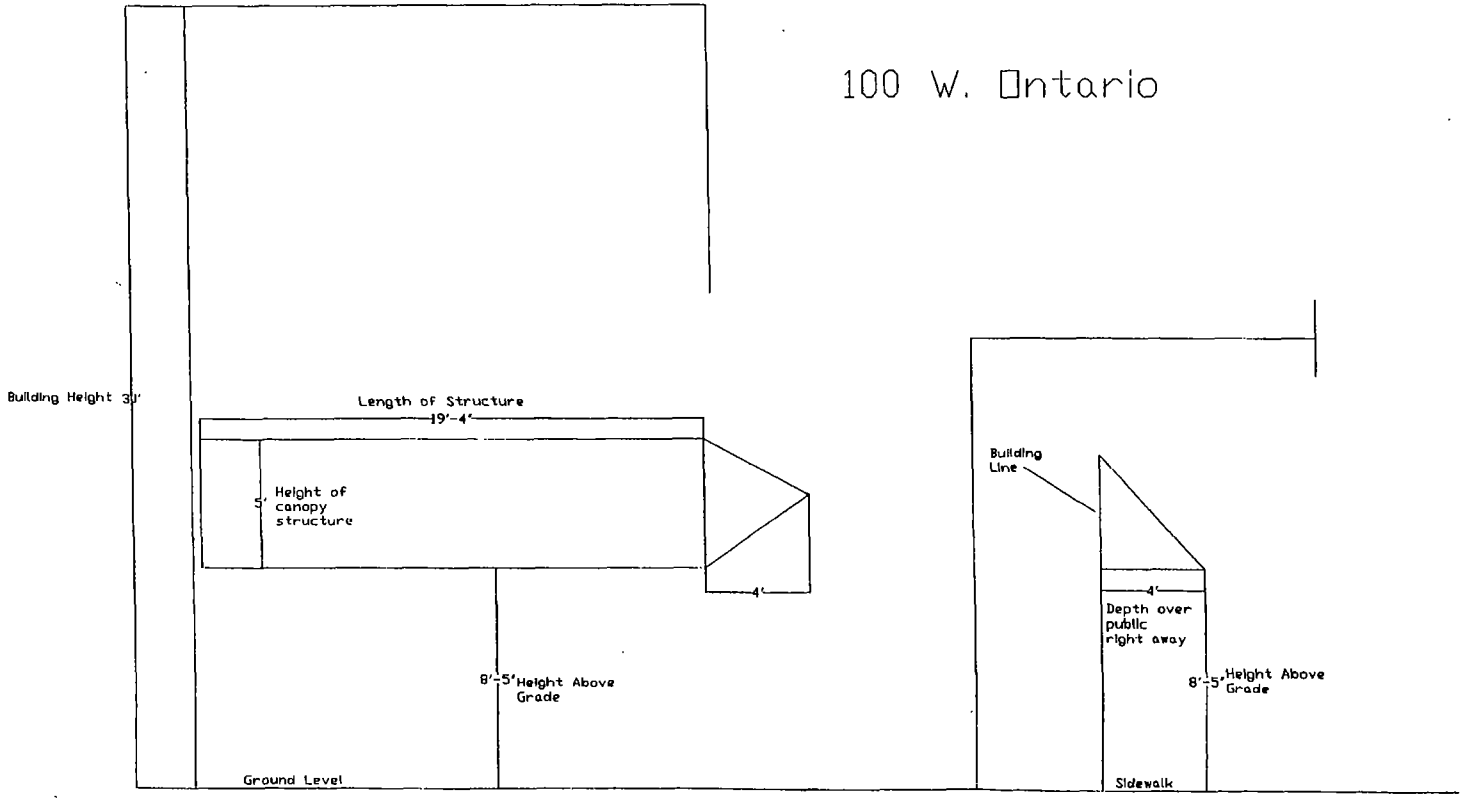



City of Chicago



O2014-4614

Office of the City Clerk

Document Tracking Sheet

| | |
|---------------------------------|--|
| Meeting Date: | 5/28/2014 |
| Sponsor(s): | Reilly (42) |
| Type: | Ordinance |
| Title: | Canopy(s) for Reit Management & Research LLC |
| Committee(s) Assignment: | Committee on Transportation and Public Way |

ORDINANCE
Reit Management & Research LLC
Acct. No. 369088 - 1
Permit No. 1111265

Be It Ordained by the City Council of the City of Chicago:

SECTION 1. Permission and authority are hereby given and granted to Reit Management & Research LLC, upon the terms and subject to the conditions of this ordinance to construct, install, maintain and use one (1) Canopy(s) projecting over the public right-of-way adjacent to its premises known as 111 E. Wacker Dr..

Said Canopy(s) at E. Wacker Drive measure(s):

One (1) at twenty-five point seven five (25.75) feet in length, and seven point five eight (7.58) feet in width for a total of one hundred ninety-five point one nine (195.19) square feet.

The location of said privilege shall be as shown on prints kept on file with the Department of Business Affairs and Consumer Protection and the Office of the City Clerk.

Said privilege shall be constructed in accordance with plans and specifications approved by the Zoning Department - Signs.

This grant of privilege in the public way shall be subject to the provisions of Section 10-28-015 and all other required provisions of the Municipal Code of Chicago.

The grantee shall pay to the City of Chicago as compensation for the privilege #1111265 herein granted the sum of fifty dollars and seventy-five cents (\$50.75) per annum in advance.

A 25% penalty will be added for payments received after due date.

The permit holder agrees to hold the City of Chicago harmless for any damage, relocation or replacement costs associated with damage, relocation or removal of private property caused by the City performing work in the public way.

Authority herein given and granted for a period of five (5) years from and after Date of Passage.

Alderman _____

Brendan Reilly 42nd Ward

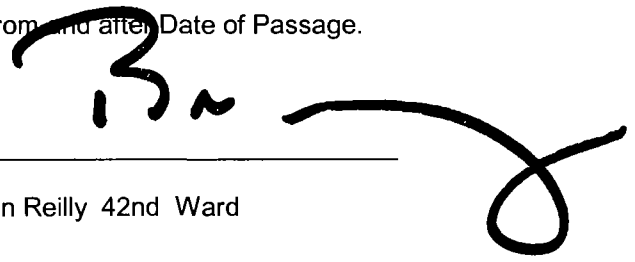
A large, stylized handwritten signature in black ink, appearing to read 'B. Reilly', is written over the signature line and extends to the right.

Handwritten scribbles or marks, possibly a signature or initials, located in the lower-left quadrant of the page.

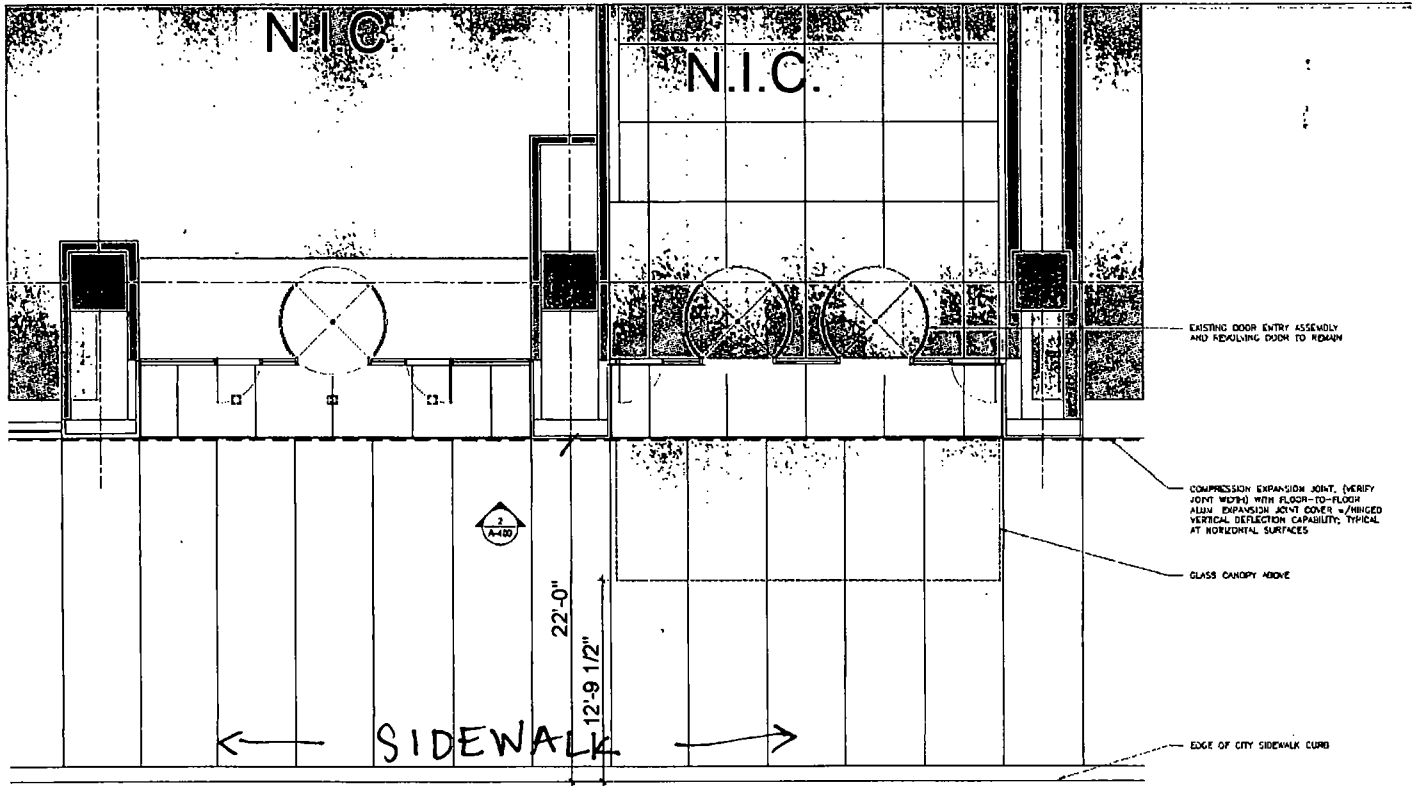

111 E. WACKER DR.
Permit #1111265

1 ENLARGED ENTRANCE FLOOR PLAN
SCALE: 1/4" = 1'-0" PI LEVEL ENTRANCES



City of Chicago



O2014-4624

Office of the City Clerk

Document Tracking Sheet

| | |
|---------------------------------|--|
| Meeting Date: | 5/28/2014 |
| Sponsor(s): | Reilly (42) |
| Type: | Ordinance |
| Title: | Canopy(s) for 535 North Michigan Venture LLC |
| Committee(s) Assignment: | Committee on Transportation and Public Way |

ORDINANCE
535 NORTH MICHIGAN VENTURE, LLC
Acct. No. 30810 - 2
Permit No. 1112930

Be It Ordained by the City Council of the City of Chicago:

SECTION 1. Permission and authority are hereby given and granted to 535 NORTH MICHIGAN VENTURE, LLC, upon the terms and subject to the conditions of this ordinance to construct, install, maintain and use three (3) Canopy(s) projecting over the public right-of-way adjacent to its premises known as 535 N. Michigan Ave..

Said Canopy(s) at N Michigan Ave measure(s):

One (1) at sixteen (16) feet in length, and three (3) feet in width for a total of forty-eight (48) square feet.

One (1) at seven (7) feet in length, and three (3) feet in width for a total of twenty-one (21) square feet.

One (1) at fifty-one point seven five (51.75) feet in length, and three (3) feet in width for a total of one hundred fifty-five point two five (155.25) square feet.

The location of said privilege shall be as shown on prints kept on file with the Department of Business Affairs and Consumer Protection and the Office of the City Clerk.

Said privilege shall be constructed in accordance with plans and specifications approved by the Zoning Department - Signs.

This grant of privilege in the public way shall be subject to the provisions of Section 10-28-015 and all other required provisions of the Municipal Code of Chicago.

The grantee shall pay to the City of Chicago as compensation for the privilege #1112930 herein granted the sum of one hundred seventy-five (\$175.00) per annum in advance.

A 25% penalty will be added for payments received after due date.

The permit holder agrees to hold the City of Chicago harmless for any damage, relocation or replacement costs associated with damage, relocation or removal of private property caused by the City performing work in the public way.

Authority herein given and granted for a period of five (5) years from and after Date of Passage.

Alderman _____

Brendan Reilly 42nd Ward

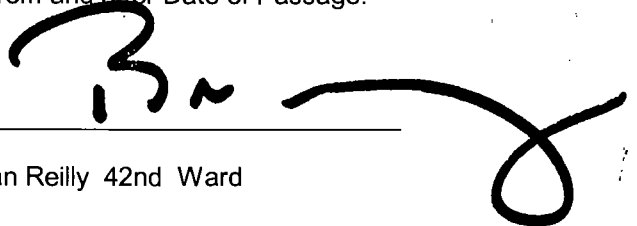
A large, stylized handwritten signature in black ink, appearing to read 'B. Reilly', is written over a horizontal line. The signature is fluid and cursive, with a large loop at the end.

Handwritten scribbles or marks, possibly initials or a signature, located in the lower-left quadrant of the page.

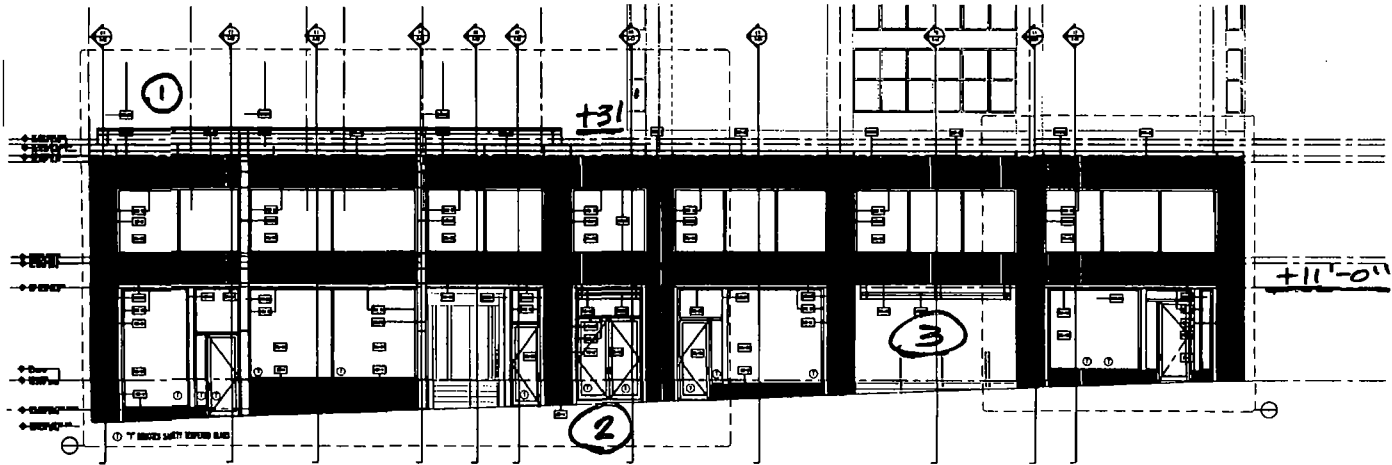

06 MICHIGAN AVENUE ELEVATION
SCALE 3/8" = 1'-0"

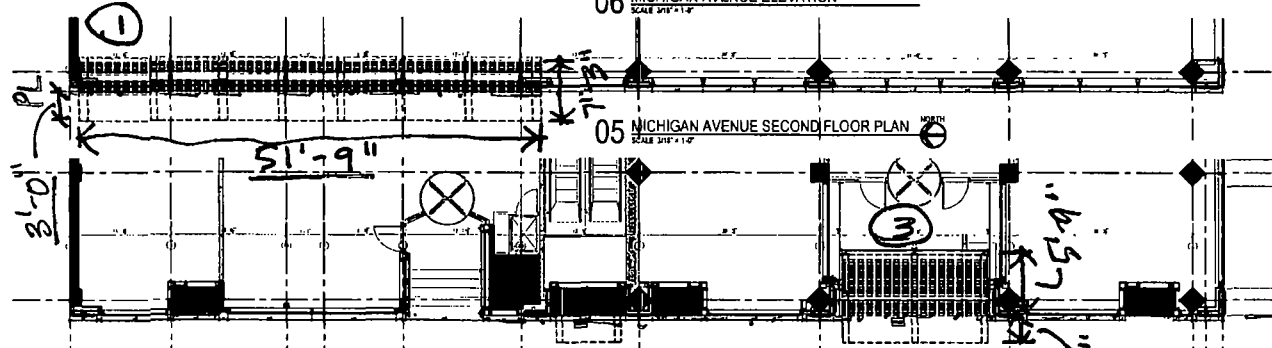

05 MICHIGAN AVENUE SECOND FLOOR PLAN
SCALE 3/8" = 1'-0"



04 MICHIGAN AVENUE FIRST FLOOR PLAN
SCALE 3/8" = 1'-0"

535 N MICHIGAN AVENUE · ROW APPLICATION — CANOPIES (3)



City of Chicago



O2014-4658

Office of the City Clerk

Document Tracking Sheet

| | |
|---------------------------------|--|
| Meeting Date: | 5/28/2014 |
| Sponsor(s): | Smith (43) |
| Type: | Ordinance |
| Title: | Canopy(s) for Public Storage |
| Committee(s) Assignment: | Committee on Transportation and Public Way |

ORDINANCE
PUBLIC STORAGE
Acct. No. 211743 - 13
Permit No. 1112851

Be It Ordained by the City Council of the City of Chicago:

SECTION 1. Permission and authority are hereby given and granted to PUBLIC STORAGE, upon the terms and subject to the conditions of this ordinance to maintain and use, as now constructed, one (1) Canopy(s) projecting over the public right-of-way adjacent to its premises known as 1129 N. Wells St..

Said Canopy(s) at N. Wells Street & W. Elm Street measure(s):
One (1) at seventy-six (76) feet in length, and three (3) feet in width for a total of two hundred twenty-eight (228) square feet.

The location of said privilege shall be as shown on prints kept on file with the Department of Business Affairs and Consumer Protection and the Office of the City Clerk.

Said privilege shall be constructed in accordance with plans and specifications approved by the Zoning Department - Signs.

This grant of privilege in the public way shall be subject to the provisions of Section 10-28-015 and all other required provisions of the Municipal Code of Chicago.

The grantee shall pay to the City of Chicago as compensation for the privilege #1112851 herein granted the sum of one hundred one (\$101.00) per annum in advance.

A 25% penalty will be added for payments received after due date.

The permit holder agrees to hold the City of Chicago harmless for any damage, relocation or replacement costs associated with damage, relocation or removal of private property caused by the City performing work in the public way.

Authority herein given and granted for a period of five (5) years from and after 11/19/2013.

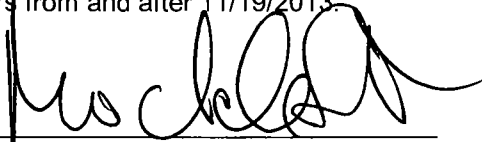
Alderman 

Michele Smith 43rd Ward

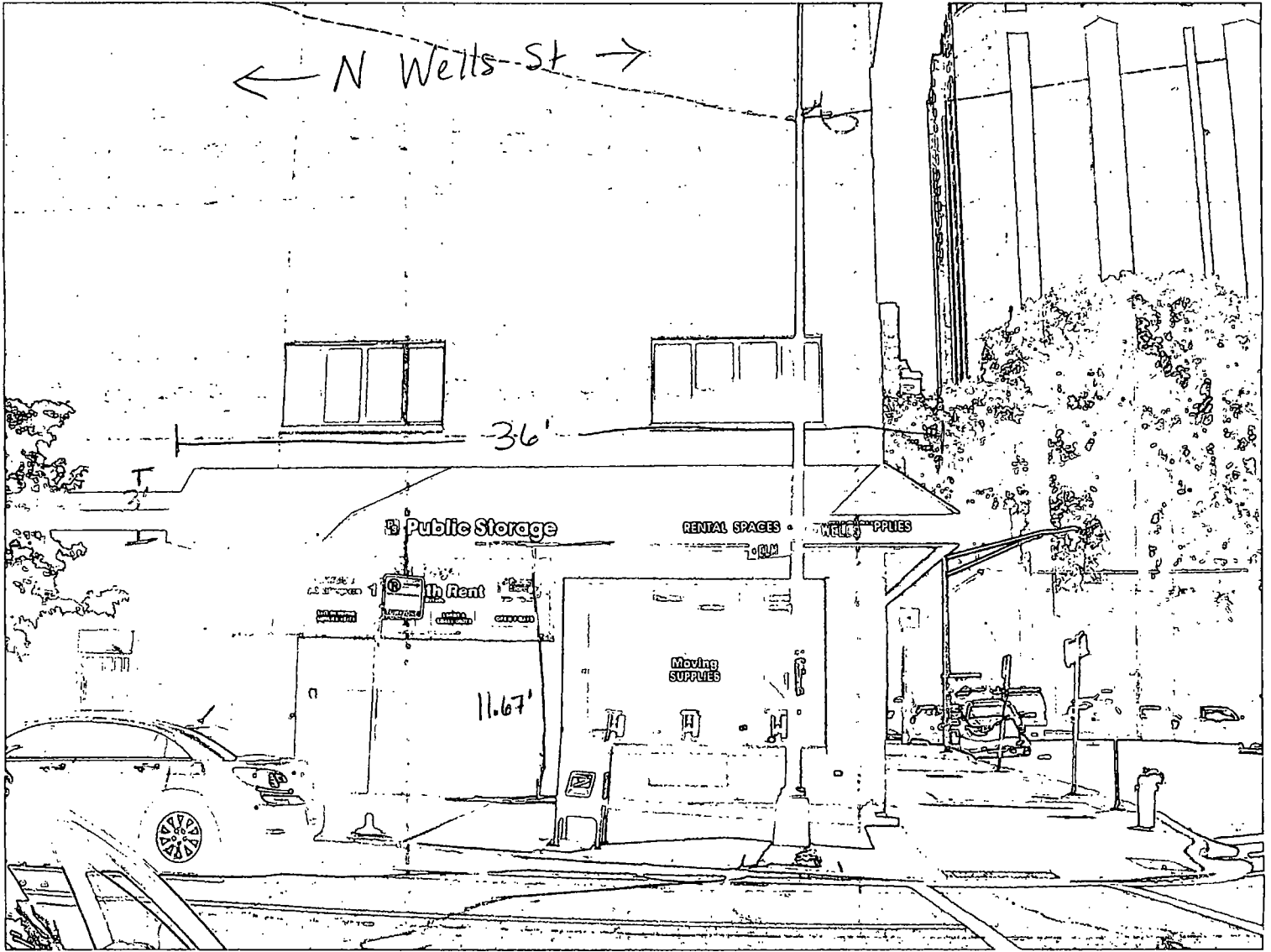



City of Chicago



O2014-4665

Office of the City Clerk

Document Tracking Sheet

| | |
|---------------------------------|--|
| Meeting Date: | 5/28/2014 |
| Sponsor(s): | Tunney (44) |
| Type: | Ordinance |
| Title: | Canopy(s) for Days Inn Chicago |
| Committee(s) Assignment: | Committee on Transportation and Public Way |

ORDINANCE
DAYS INN CHICAGO
Acct. No. 30696 - 4
Permit No. 1113105

Be It Ordained by the City Council of the City of Chicago:

SECTION 1. Permission and authority are hereby given and granted to DAYS INN CHICAGO, upon the terms and subject to the conditions of this ordinance to maintain and use, as now constructed, two (2) Canopy(s) projecting over the public right-of-way adjacent to its premises known as 644 W. Diversey Pkwy..

Said Canopy(s) at W.DIVERSEY PKWY. measure(s):

One (1) at ten point three (10.3) feet in length, and eight (8) feet in width for a total of eighty-two point four (82.4) square feet.

Said Canopy(s) at W. DIVERSEY measure(s):

One (1) at fifty point three six (50.36) feet in length, and two point five two (2.52) feet in width for a total of one hundred twenty-six point nine one (126.91) square feet.

The location of said privilege shall be as shown on prints kept on file with the Department of Business Affairs and Consumer Protection and the Office of the City Clerk.

Said privilege shall be constructed in accordance with plans and specifications approved by the Zoning Department - Signs.

This grant of privilege in the public way shall be subject to the provisions of Section 10-28-015 and all other required provisions of the Municipal Code of Chicago.

The grantee shall pay to the City of Chicago as compensation for the privilege #1113105 herein granted the sum of one hundred twenty-five dollars and thirty-six cents (\$125.36) per annum in advance.

A 25% penalty will be added for payments received after due date.

The permit holder agrees to hold the City of Chicago harmless for any damage, relocation or replacement costs associated with damage, relocation or removal of private property caused by the City performing work in the public way.

Authority herein given and granted for a period of five (5) years from and after 05/04/2014.

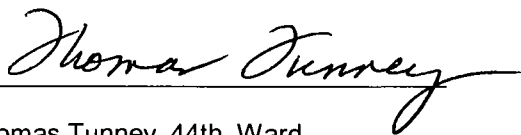
Alderman 
Thomas Tunney 44th Ward



Days Inn Chicago, 644 West Diversey Parkway, Chicago, IL 60614
Tel: 773-525-7010 Fax: 773-525-6998
www.daysinnchicago.net

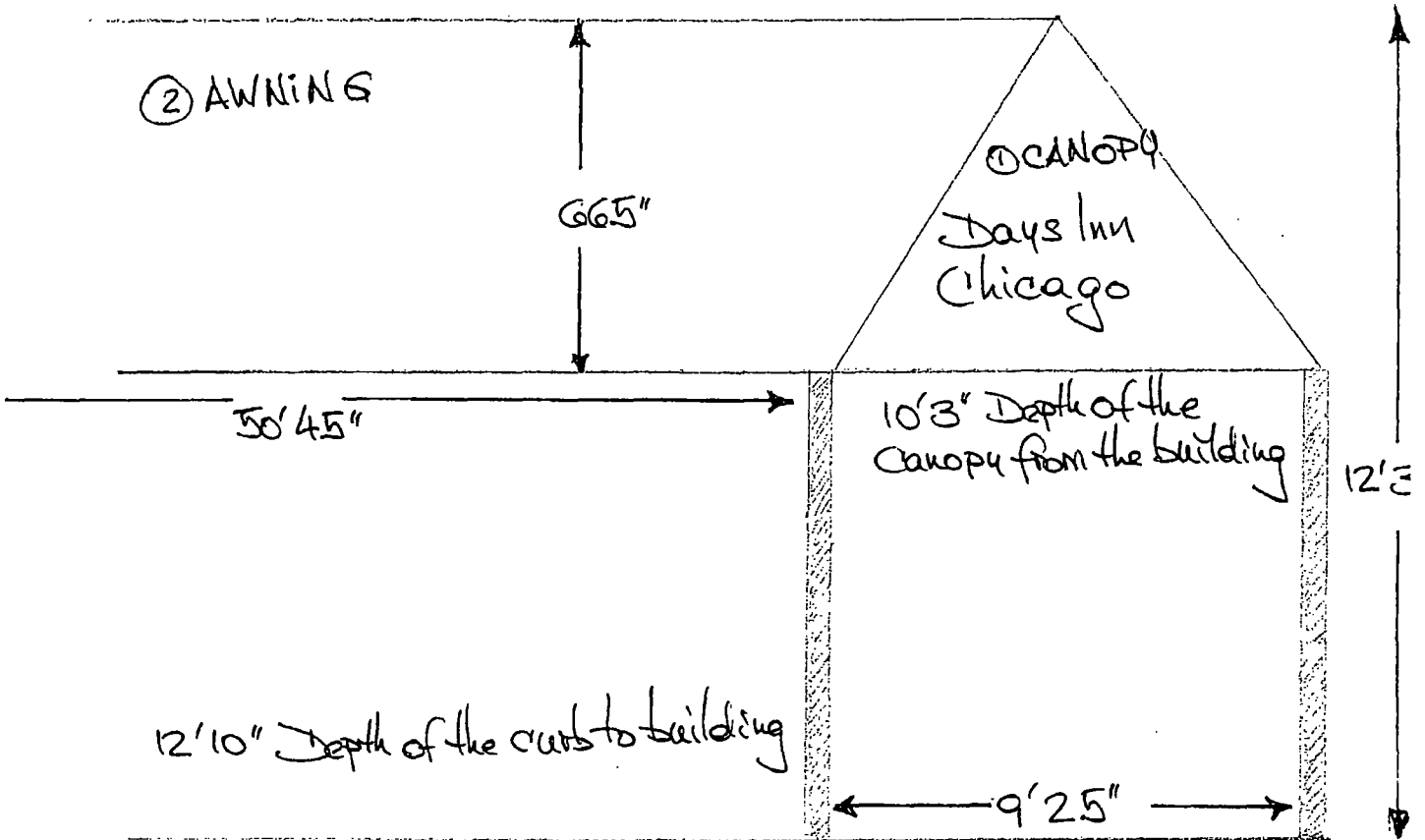



Stefanie Hrejsa
General Manager
644 W. Diversey Parkway
Chicago, IL 60614
T. 773.525.7010 x115
F. 773.687.5213
shrejsa@daysinnchicago.net
www.daysinnchicago.net

① Canopy (over entrance)
Dimensions

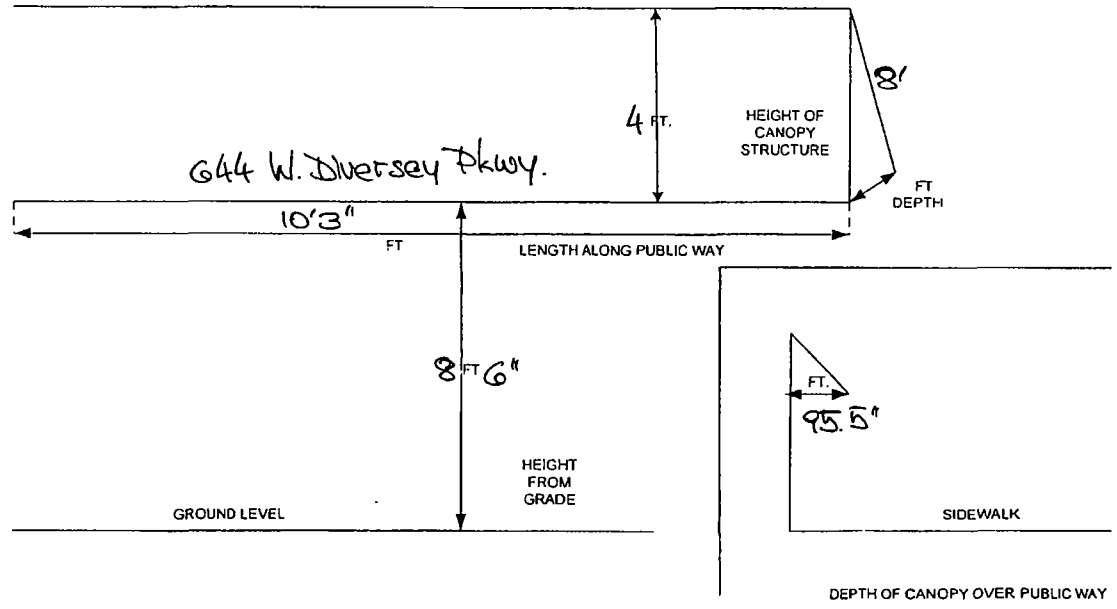



Award-winning Hotel

Stefanie Hrejsa
General Manager
644 W. Diversey Parkway
Chicago, IL 60614
t. 773.525.7010 x115
f. 773.687.5213
shrejsa@daysinnchicago.net
www.daysinnchicago.net

② Awning (to left of entrance)
Dimensions

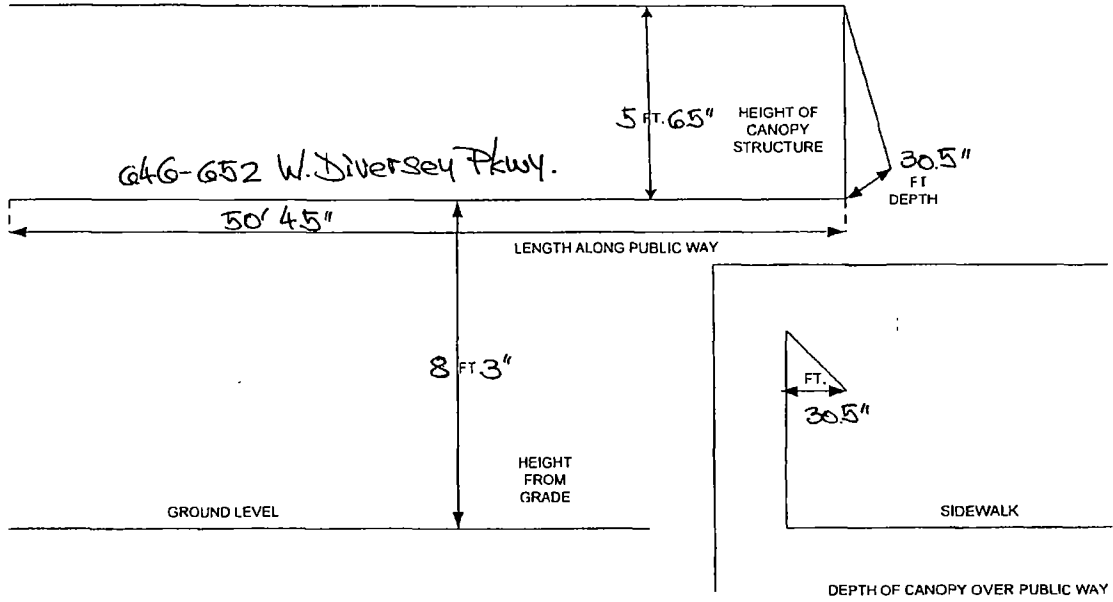



City of Chicago



O2014-4667

Office of the City Clerk

Document Tracking Sheet

| | |
|---------------------------------|--|
| Meeting Date: | 5/28/2014 |
| Sponsor(s): | Tunney (44) |
| Type: | Ordinance |
| Title: | Canopy(s) for Ann Sather's Cafe |
| Committee(s) Assignment: | Committee on Transportation and Public Way |

ORDINANCE
ANN SATHER'S CAFE
Acct. No. 2962 - 4
Permit No. 1113033

Be It Ordained by the City Council of the City of Chicago:

SECTION 1. Permission and authority are hereby given and granted to ANN SATHER'S CAFE, upon the terms and subject to the conditions of this ordinance to maintain and use, as now constructed, one (1) Canopy(s) projecting over the public right-of-way adjacent to its premises known as 3411 N. Broadway .

Said Canopy(s) at N. BROADWAY measure(s):

One (1) at thirty (30) feet in length, and two (2) feet in width for a total of sixty (60) square feet.

The location of said privilege shall be as shown on prints kept on file with the Department of Business Affairs and Consumer Protection and the Office of the City Clerk.

Said privilege shall be constructed in accordance with plans and specifications approved by the Zoning Department - Signs.

This grant of privilege in the public way shall be subject to the provisions of Section 10-28-015 and all other required provisions of the Municipal Code of Chicago.

The grantee shall pay to the City of Chicago as compensation for the privilege #1113033 herein granted the sum of fifty-five (\$55.00) per annum in advance.

A 25% penalty will be added for payments received after due date.

The permit holder agrees to hold the City of Chicago harmless for any damage, relocation or replacement costs associated with damage, relocation or removal of private property caused by the City performing work in the public way.

Authority herein given and granted for a period of five (5) years from and after 04/26/2014.

Alderman Thomas Tunney
Thomas Tunney 44th Ward

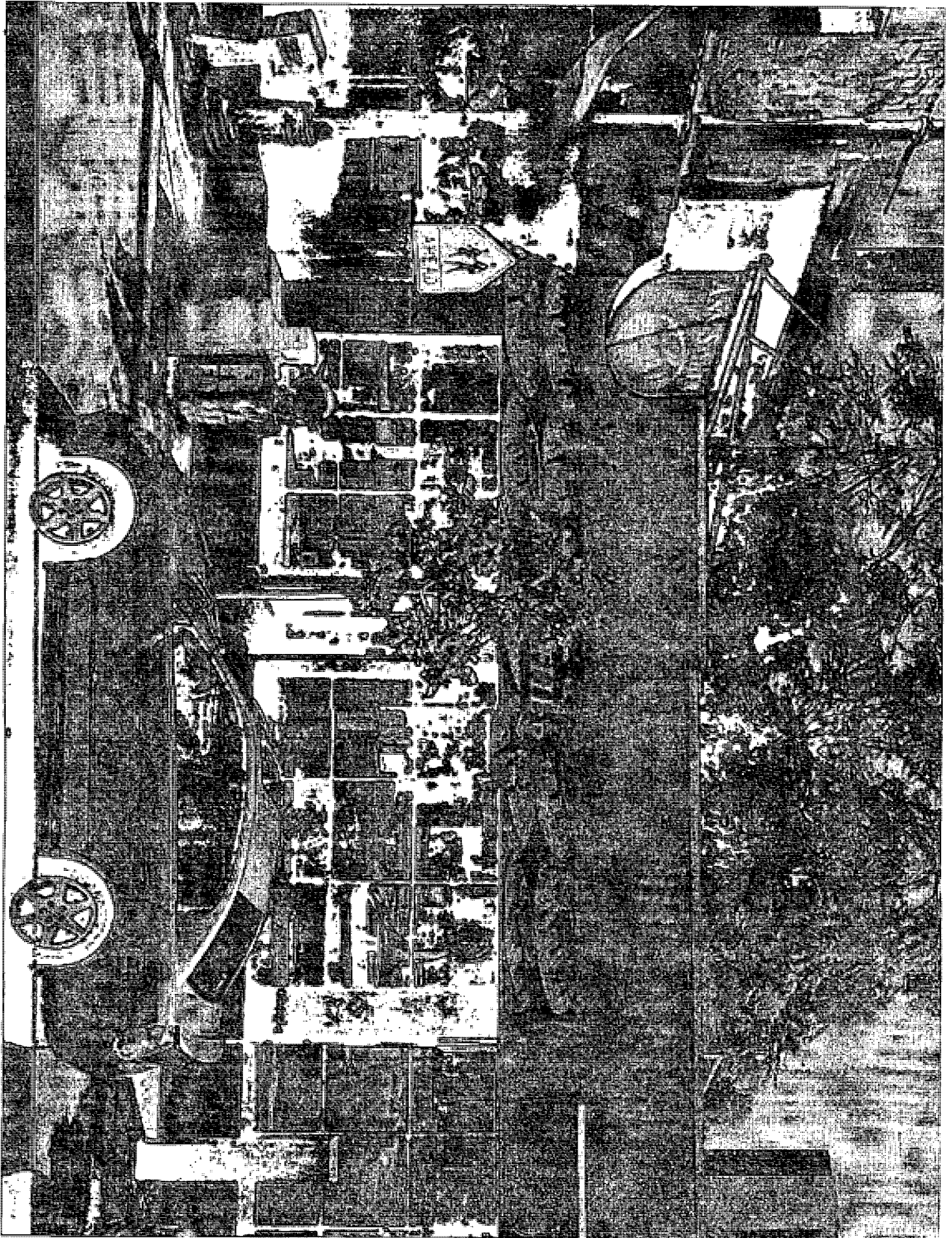



City of Chicago



O2014-4669

Office of the City Clerk

Document Tracking Sheet

| | |
|---------------------------------|--|
| Meeting Date: | 5/28/2014 |
| Sponsor(s): | Tunney (44) |
| Type: | Ordinance |
| Title: | Canopy(s) for Omalley's Liquor Kitchen |
| Committee(s) Assignment: | Committee on Transportation and Public Way |

ORDINANCE
OMALLEY'S LIQUOR KITCHEN
Acct. No. 8109 - 1
Permit No. 1113117

Be It Ordained by the City Council of the City of Chicago:

SECTION 1. Permission and authority are hereby given and granted to OMALLEY'S LIQUOR KITCHEN, upon the terms and subject to the conditions of this ordinance to maintain and use, as now constructed, one (1) Canopy(s) projecting over the public right-of-way adjacent to its premises known as 3551 N. Sheffield Ave..

Said Canopy(s) at N. Sheffield Avenue measure(s):

One (1) at eight (8) feet in length, and seven (7) feet in width for a total of fifty-six (56) square feet.

The location of said privilege shall be as shown on prints kept on file with the Department of Business Affairs and Consumer Protection and the Office of the City Clerk.

Said privilege shall be constructed in accordance with plans and specifications approved by the Zoning Department - Signs.

This grant of privilege in the public way shall be subject to the provisions of Section 10-28-015 and all other required provisions of the Municipal Code of Chicago.

The grantee shall pay to the City of Chicago as compensation for the privilege #1113117 herein granted the sum of fifty (\$50.00) per annum in advance.

A 25% penalty will be added for payments received after due date.

The permit holder agrees to hold the City of Chicago harmless for any damage, relocation or replacement costs associated with damage, relocation or removal of private property caused by the City performing work in the public way.

Authority herein given and granted for a period of five (5) years from and after 07/27/2013.

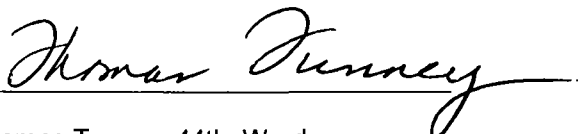
Alderman 
Thomas Tunney 44th Ward

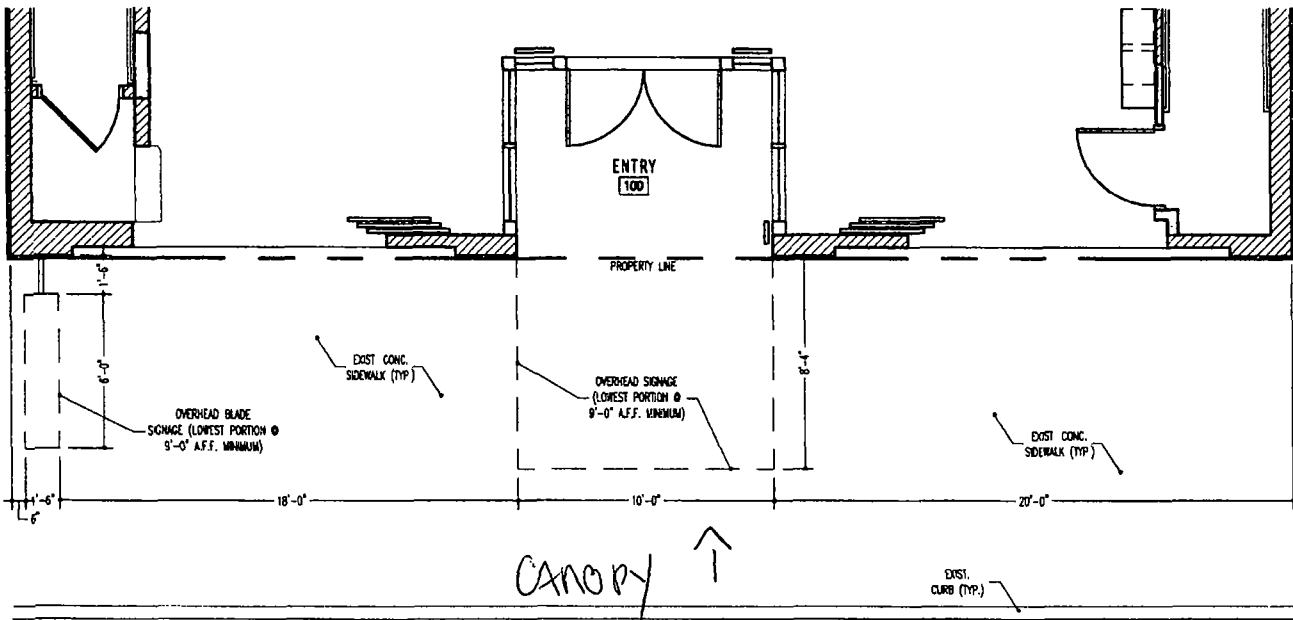

N. SHEFFIELD AVENUE



ASK501 EXISTING SITE PLAN

SCALE:

3/16"=1'-0"

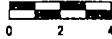

| | |
|----------------|-----------|
| PROJECT NUMBER | 100 |
| ISSUE DATE | 10-1-2010 |
| DATE OF ISSUE | 10-1-2010 |

+ baker/nestor +
 ARCHITECTURE + DESIGN
 615 WASHINGTON AVE. SUITE 1000
 ST. LOUIS, MO 63101
 TEL: 314.433.1100 FAX: 314.433.1107

RESTAURANT & BAR RENOVATIONS
 3001 N. SHEFFIELD AVE.
 ST. LOUIS, MO 63103

ASK5



City of Chicago



O2014-4670

Office of the City Clerk

Document Tracking Sheet

| | |
|---------------------------------|--|
| Meeting Date: | 5/28/2014 |
| Sponsor(s): | Tunney (44) |
| Type: | Ordinance |
| Title: | Canopy(s) for Salt & Pepper Diner |
| Committee(s) Assignment: | Committee on Transportation and Public Way |

ORDINANCE
SALT & PEPPER DINER
Acct. No. 89311 - 1
Permit No. 1112991

Be It Ordained by the City Council of the City of Chicago:

SECTION 1. Permission and authority are hereby given and granted to SALT & PEPPER DINER, upon the terms and subject to the conditions of this ordinance to maintain and use, as now constructed, one (1) Canopy(s) projecting over the public right-of-way adjacent to its premises known as 3537 N. Clark St..

Said Canopy(s) at N. Clark Street measure(s):

One (1) at fifteen (15) feet in length, and three point four (3.4) feet in width for a total of fifty-one (51) square feet.

The location of said privilege shall be as shown on prints kept on file with the Department of Business Affairs and Consumer Protection and the Office of the City Clerk.

Said privilege shall be constructed in accordance with plans and specifications approved by the Zoning Department - Signs.

This grant of privilege in the public way shall be subject to the provisions of Section 10-28-015 and all other required provisions of the Municipal Code of Chicago.

The grantee shall pay to the City of Chicago as compensation for the privilege #1112991 herein granted the sum of fifty (\$50.00) per annum in advance.

A 25% penalty will be added for payments received after due date.

The permit holder agrees to hold the City of Chicago harmless for any damage, relocation or replacement costs associated with damage, relocation or removal of private property caused by the City performing work in the public way.

Authority herein given and granted for a period of five (5) years from and after 01/13/2014.

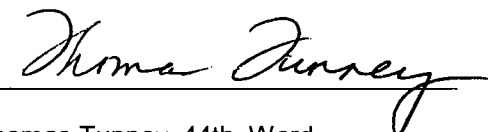
Alderman 
Thomas Tunney 44th Ward

S&P DINER
3537 NORTH CLARK
CHICAGO

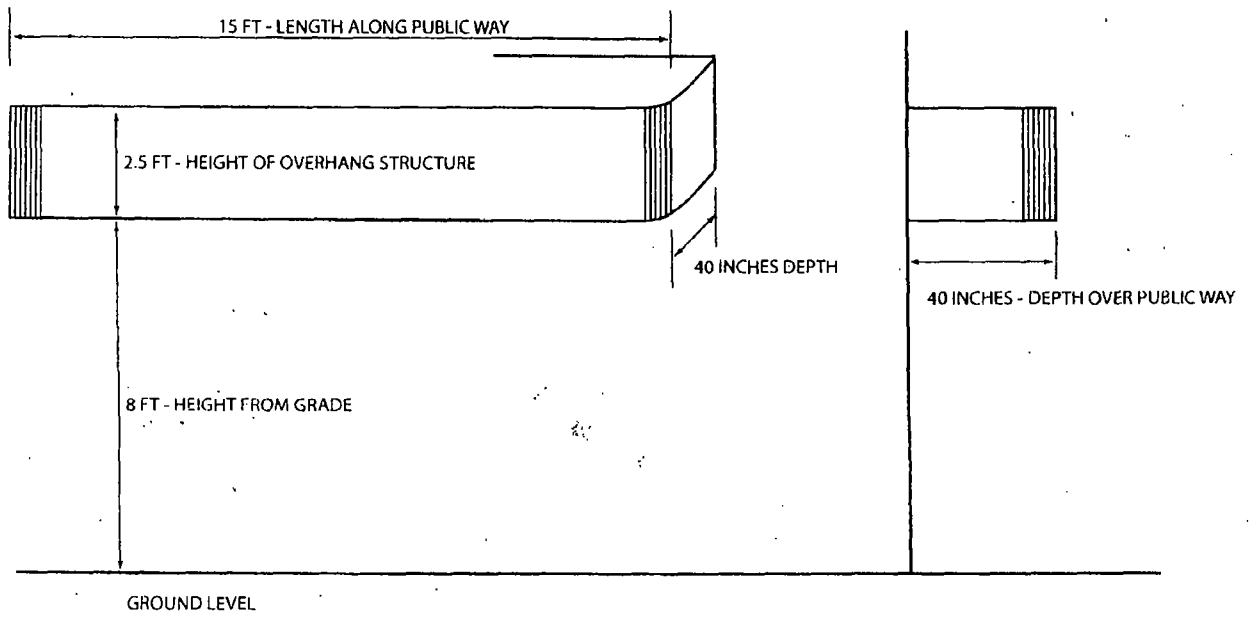



City of Chicago



O2014-4672

Office of the City Clerk

Document Tracking Sheet

| | |
|---------------------------------|--|
| Meeting Date: | 5/28/2014 |
| Sponsor(s): | Tunney (44) |
| Type: | Ordinance |
| Title: | Canopy(s) for Self Storage No. 1 |
| Committee(s) Assignment: | Committee on Transportation and Public Way |

ORDINANCE
SELF STORAGE #1
Acct. No. 59931 - 3
Permit No. 1112742

Be It Ordained by the City Council of the City of Chicago:

SECTION 1. Permission and authority are hereby given and granted to SELF STORAGE #1, upon the terms and subject to the conditions of this ordinance to maintain and use, as now constructed, two (2) Canopy(s) projecting over the public right-of-way adjacent to its premises known as 3839 N. Sheffield Ave..

Said Canopy(s) at N. Sheffield Avenue measure(s):

One (1) at thirteen (13) feet in length, and eight (8) feet in width for a total of one hundred four (104) square feet.

Said Canopy(s) at N. Sheridan Road measure(s):

One (1) at thirteen (13) feet in length, and eight (8) feet in width for a total of one hundred four (104) square feet.

The location of said privilege shall be as shown on prints kept on file with the Department of Business Affairs and Consumer Protection and the Office of the City Clerk.

Said privilege shall be constructed in accordance with plans and specifications approved by the Zoning Department - Signs.

This grant of privilege in the public way shall be subject to the provisions of Section 10-28-015 and all other required provisions of the Municipal Code of Chicago.

The grantee shall pay to the City of Chicago as compensation for the privilege #1112742 herein granted the sum of one hundred (\$100.00) per annum in advance.

A 25% penalty will be added for payments received after due date.

The permit holder agrees to hold the City of Chicago harmless for any damage, relocation or replacement costs associated with damage, relocation or removal of private property caused by the City performing work in the public way.

Authority herein given and granted for a period of five (5) years from and after Date of Passage.

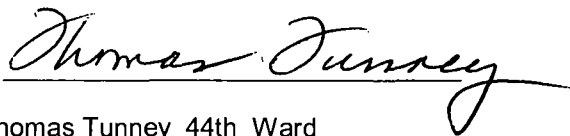
Alderman 
Thomas Tunney 44th Ward

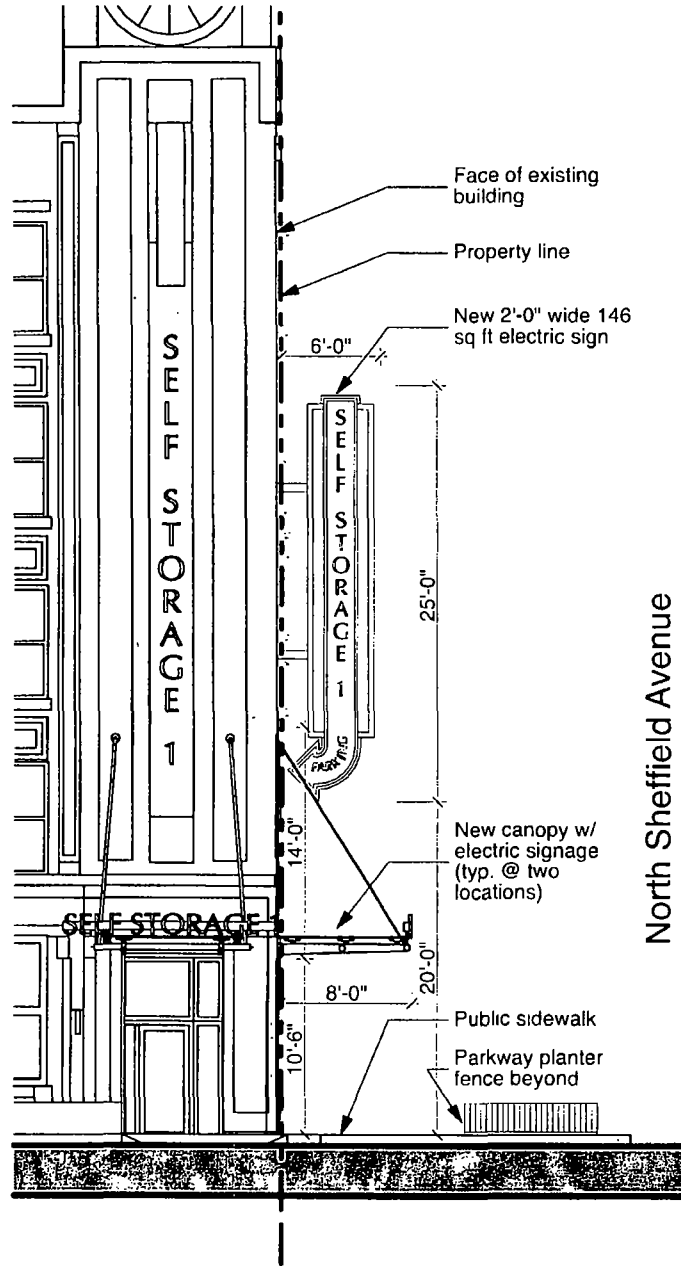

Canopy & Sign Elevation (Use of Public Way Application)
Scale 3/32" = 1'-0"

Self Storage 1
3839 N. Sheffield Ave.
Chicago, IL

Cardiff Mason Development Inc.
developer



pappageorgehaymes partners
www.pappageorgehaymes.com

4/11/14
P/H # 132190

These drawings are schematic and are subject to further refinements for compliance with code requirements, fire safety requirements and coordination with existing systems.



City of Chicago



O2014-4660

Office of the City Clerk

Document Tracking Sheet

| | |
|---------------------------------|---|
| Meeting Date: | 5/28/2014 |
| Sponsor(s): | Pawar (47) |
| Type: | Ordinance |
| Title: | Canopy(s) for Architectural Artifacts, Inc. |
| Committee(s) Assignment: | Committee on Transportation and Public Way |

ORDINANCE
ARCHITECTURAL ARTIFACTS, INC
Acct. No. 14579 - 3
Permit No. 1113114

Be It Ordained by the City Council of the City of Chicago:

SECTION 1. Permission and authority are hereby given and granted to ARCHITECTURAL ARTIFACTS, INC, upon the terms and subject to the conditions of this ordinance to maintain and use, as now constructed, one (1) Canopy(s) projecting over the public right-of-way adjacent to its premises known as 4325-43 N. Ravenswood Ave..

Said Canopy(s) at N. Ravenswood measure(s):

One (1) at eighteen point five (18.5) feet in length, and three (3) feet in width for a total of fifty-five point five (55.5) square feet.

The location of said privilege shall be as shown on prints kept on file with the Department of Business Affairs and Consumer Protection and the Office of the City Clerk.

Said privilege shall be constructed in accordance with plans and specifications approved by the Zoning Department - Signs.

This grant of privilege in the public way shall be subject to the provisions of Section 10-28-015 and all other required provisions of the Municipal Code of Chicago.

The grantee shall pay to the City of Chicago as compensation for the privilege #1113114 herein granted the sum of fifty (\$50.00) per annum in advance.

A 25% penalty will be added for payments received after due date.

The permit holder agrees to hold the City of Chicago harmless for any damage, relocation or replacement costs associated with damage, relocation or removal of private property caused by the City performing work in the public way.

Authority herein given and granted for a period of five (5) years from and after 04/22/2014.

Alderman 
Ameya Pawar 47th Ward

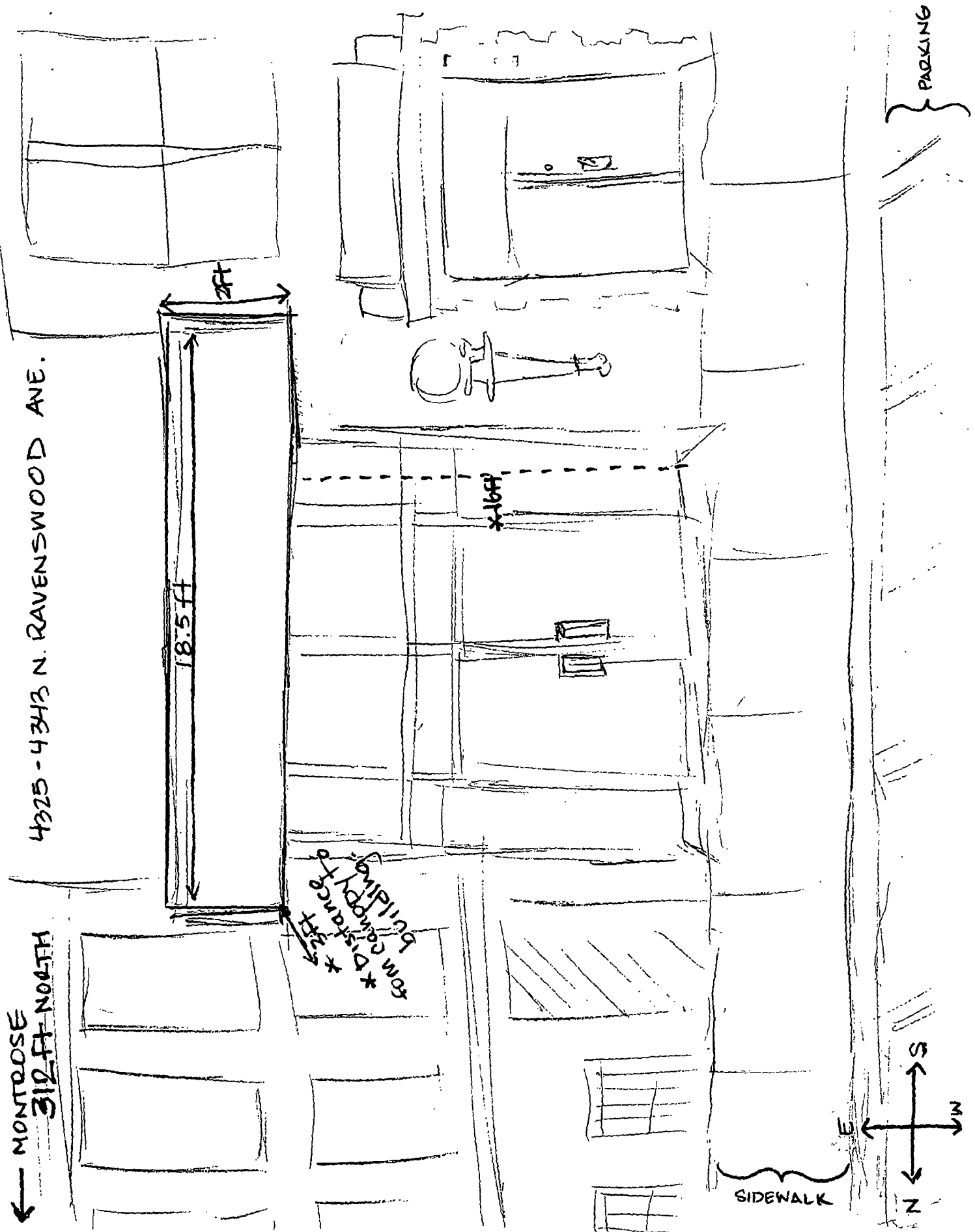



05/28/2014

Alderman **Ameya Pawar**
Ward # 47
City of Chicago
City Hall, Room 300
121 North LaSalle Street
Chicago, Illinois 60602

Re: An ordinance to use and maintain a portion of the public right-of-way for **one (1) canopy(ies)** for **ARCHITECTURAL ARTIFACTS, INC**, adjacent to the premises known as **4325-43 N. Ravenswood Ave.**

Dear Alderman **Ameya Pawar**:

The applicant referenced above has requested the use of the public right-of-way for a **canopy(ies)**. An ordinance has been prepared by the Department of Business Affairs and Consumer Protection – Small Business Center - Public Way Use Unit for presentation to the City Council. Because this request was made for properties located in your ward, as approved by you as per the attached, I respectfully request that you introduce the attached ordinance at the next City Council meeting.

If you have any questions regarding this ordinance, please contact Anthony Bertuca at (312) 744-5506.

Department of Business Affairs and Consumer Protection



City of Chicago



O2014-4664

Office of the City Clerk

Document Tracking Sheet

| | |
|---------------------------------|--|
| Meeting Date: | 5/28/2014 |
| Sponsor(s): | Osterman (48) |
| Type: | Ordinance |
| Title: | Canopy(s) for Holsten Management Corp. |
| Committee(s) Assignment: | Committee on Transportation and Public Way |

ORDINANCE

Holsten Management Corporation

Acct. No. 88134 - 1

Permit No. 1112875

Be It Ordained by the City Council of the City of Chicago:

SECTION 1. Permission and authority are hereby given and granted to Holsten Management Corporation, upon the terms and subject to the conditions of this ordinance to maintain and use, as now constructed, one (1) Canopy(s) projecting over the public right-of-way adjacent to its premises known as 5550 N. Kenmore Ave..

Said Canopy(s) at N. Kenmore Avenue measure(s):

One (1) at eighteen (18) feet in length, and three (3) feet in width for a total of fifty-four (54) square feet.

The location of said privilege shall be as shown on prints kept on file with the Department of Business Affairs and Consumer Protection and the Office of the City Clerk.

Said privilege shall be constructed in accordance with plans and specifications approved by the Zoning Department - Signs.

This grant of privilege in the public way shall be subject to the provisions of Section 10-28-015 and all other required provisions of the Municipal Code of Chicago.

The grantee shall pay to the City of Chicago as compensation for the privilege #1112875 herein granted the sum of fifty (\$50.00) per annum in advance.

A 25% penalty will be added for payments received after due date.

The permit holder agrees to hold the City of Chicago harmless for any damage, relocation or replacement costs associated with damage, relocation or removal of private property caused by the City performing work in the public way.

Authority herein given and granted for a period of five (5) years from and after 05/04/2006.

Alderman _____

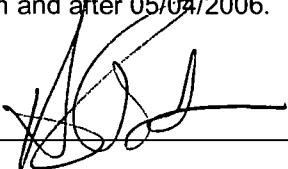
Harry Osterman 48th Ward

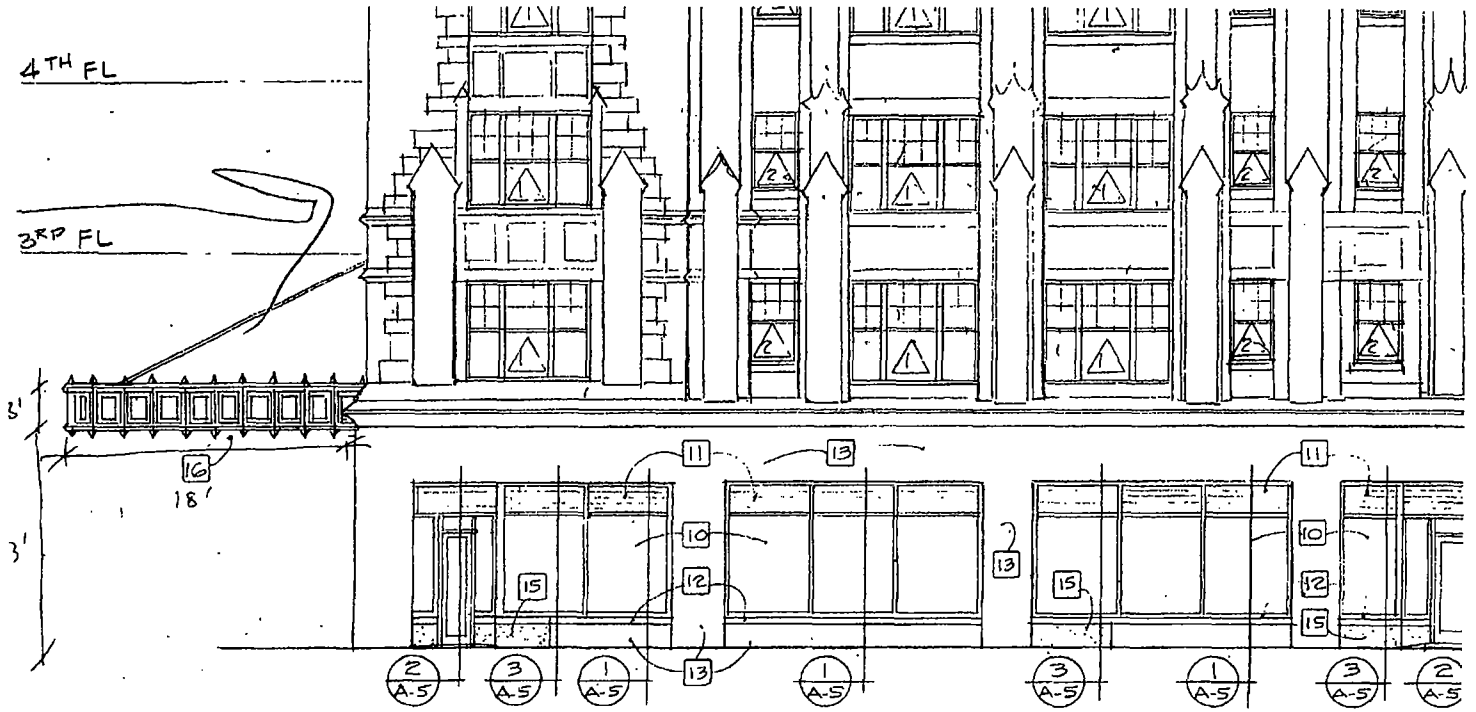

NORTH ELEVATION - BRYN MAWR
SCALE : 1/8" = 1'-0"



Department of Business Affairs and Consumer Protection
Small Business Center - Public Way Use Unit
City Hall - 121 N. LaSalle Street, Room 800 • Chicago, IL 60602
(312)-74-GOBIZ (312-744-6249) • (312) 744-1944 (TTY)
<http://www.cityofchicago.org/bacp>

05/28/2014

Alderman **Harry Osterman**
Ward # **48**
City of Chicago
City Hall, Room **300**
121 North LaSalle Street
Chicago, Illinois 60602

Re: An ordinance to use and maintain a portion of the public right-of-way for **one (1) canopy(ies)** for **Holsten Management Corporation**, adjacent to the premises known as **5550 N. Kenmore Ave.**.

Dear Alderman **Harry Osterman**:

The applicant referenced above has requested the use of the public right-of-way for a **canopy(ies)**. An ordinance has been prepared by the Department of Business Affairs and Consumer Protection – Small Business Center - Public Way Use Unit for presentation to the City Council. Because this request was made for properties located in your ward, as approved by you as per the attached, I respectfully request that you introduce the attached ordinance at the next City Council meeting.

If you have any questions regarding this ordinance, please contact Anthony Bertuca at (312) 744-5506.

Department of Business Affairs and Consumer Protection



City of Chicago



R2014-356

Office of the City Clerk

Document Tracking Sheet

Meeting Date: 5/28/2014

Sponsor(s): Balcer (11)
Reboyas (30)
Cardenas (12)
Burke (14)

Type: Resolution

Title: Call for hearing(s) to ensure our nation's veterans receive respect, honor, and timely access to health care

Committee(s) Assignment: Committee on Human Relations

Humay Retaluar

R E S O L U T I O N

WHEREAS, It recently came to light that the United States Department of Veterans Affairs's Health Care System in Phoenix, Arizona has a waiting list of nearly 1,600 veterans waiting to secure an appointment for medical care; and

WHEREAS, As a result of this massive backup in services, at least 40 veterans have died while awaiting appointments at the Phoenix facility; and

WHEREAS, Following the discovery of the debacle in Phoenix, federal authorities have opened investigations into twenty-six other VA hospitals across the country; and

WHEREAS, Chicagoland is the proud home of the Edward Hines, Jr. Veterans Administration Hospital, which serves thousands of veterans who live in and around the City of Chicago; and

WHEREAS, Hines VA Hospital is currently under federal investigation stemming from allegations that executives have surreptitiously kept patients on wait lists as part of a scheme to collect bonuses for meeting benchmarks for providing timely treatment; and

WHEREAS, Without in any way maligning the vast majority of physicians, nurses, and staff who work tirelessly and honorably to provide care at Hines, it must be said that the alleged conduct on the part of the executives at the heart of this investigation is outrageous and completely unacceptable; and

WHEREAS, President Obama has vowed to investigate impropriety at the Department of Veterans Affairs and to hold those involved accountable; and

WHEREAS, Congress plays a key role in providing oversight to federal agencies throughout the federal government and enacting legislation to ensure all VA hospitals provide care in a timely manner; now, therefore,

BE IT RESOLVED, That we, the Mayor and Members of the City Council of the City of Chicago, assembled this twenty-eighth day of May, 2014, do hereby call upon the City Council's Committee on Human Relations to hold a hearing on what actions the City of Chicago can take to ensure that our nation's veterans receive the respect, honor, and timely access to health care that they so richly deserve; and upon the federal government both to identify the root causes of the current VA crisis, and to educate state and local governments on how to best assist the federal government in this cause; and

BE IT FURTHER RESOLVED, That a suitable copy of this resolution be presented to the President of the United States, the members of the Illinois congressional delegation, and the Secretary of the United States Department of Veterans Affairs.

James A. Balcer

James A. Balcer
Alderman, 11th Ward

Ariel Reboyras

Ariel Reboyras
Alderman, 30th Ward

George A. Cardenas

George A. Cardenas 12th

Edward Hines

14th

1. 1/2

2. 1/2

3. 1/2



City of Chicago



R2014-352

Office of the City Clerk

Document Tracking Sheet

Meeting Date: 5/28/2014

Sponsor(s): Burke (14)
Laurino (39)

Type: Resolution

Title: Call on Commissioner of Department of Business Affairs and representatives of Chicago Police Department and banking and retail industry to provide information on fraud prevention and identity security when making credit card transactions

Committee(s) Assignment: Committee on Finance

Amable

RESOLUTION

WHEREAS, In 2013, approximately 98 million customers of Target stores had personal information compromised in a wide-spread hacking of payment card data, including names, phone numbers, and email address; and

WHEREAS, The United States has fallen behind on credit card fraud prevention compared to other areas of the world, where EMV or chip cards, authenticate credit and debit card transactions by generating a unique code for each transaction, making hacking more difficult and ensuring additional layers of security for consumers; and

WHEREAS, identity theft and fraudulent credit card use cost Americans billions of dollars every year; and

WHEREAS, consumers in the City of Chicago and elsewhere in the United States expect privacy and security when conducting transactions, as well as transparency and honesty from businesses when personal information is compromised; and

WHEREAS, the United States Congress has under consideration HR 3990, Personal Data Privacy and Security Act of 2014, to mitigate and prevent identity theft, ensure privacy, provide notice of security breaches, and to enhance criminal penalties, law enforcement assistance, and other protections against security breaches; and

WHEREAS, The City Council believes that passage of HR 3990 will provide consumers in Chicago and around the country enhanced protection and privacy of their personal information, and the issue of credit card fraud and identity theft in the City of Chicago is critical and costly; now therefore

BE IT RESOLVED, The Commissioner of the Department of Business Affairs and Consumer Protection, representatives of the Chicago Police Department, and representatives of the banking and retail industry are invited to appear before the Committee on Finance to provide information on the subject of fraud prevention and identity security when making credit card transactions; and

BE IT FURTHER RESOLVED, that a suitable copy of this resolution be presented to the Illinois Delegation to the United States Congress as a sign of our support of HR 3990.

Edward M. Burke
Alderman, 14th Ward

Margaret Laurino
Alderman, 39th Ward



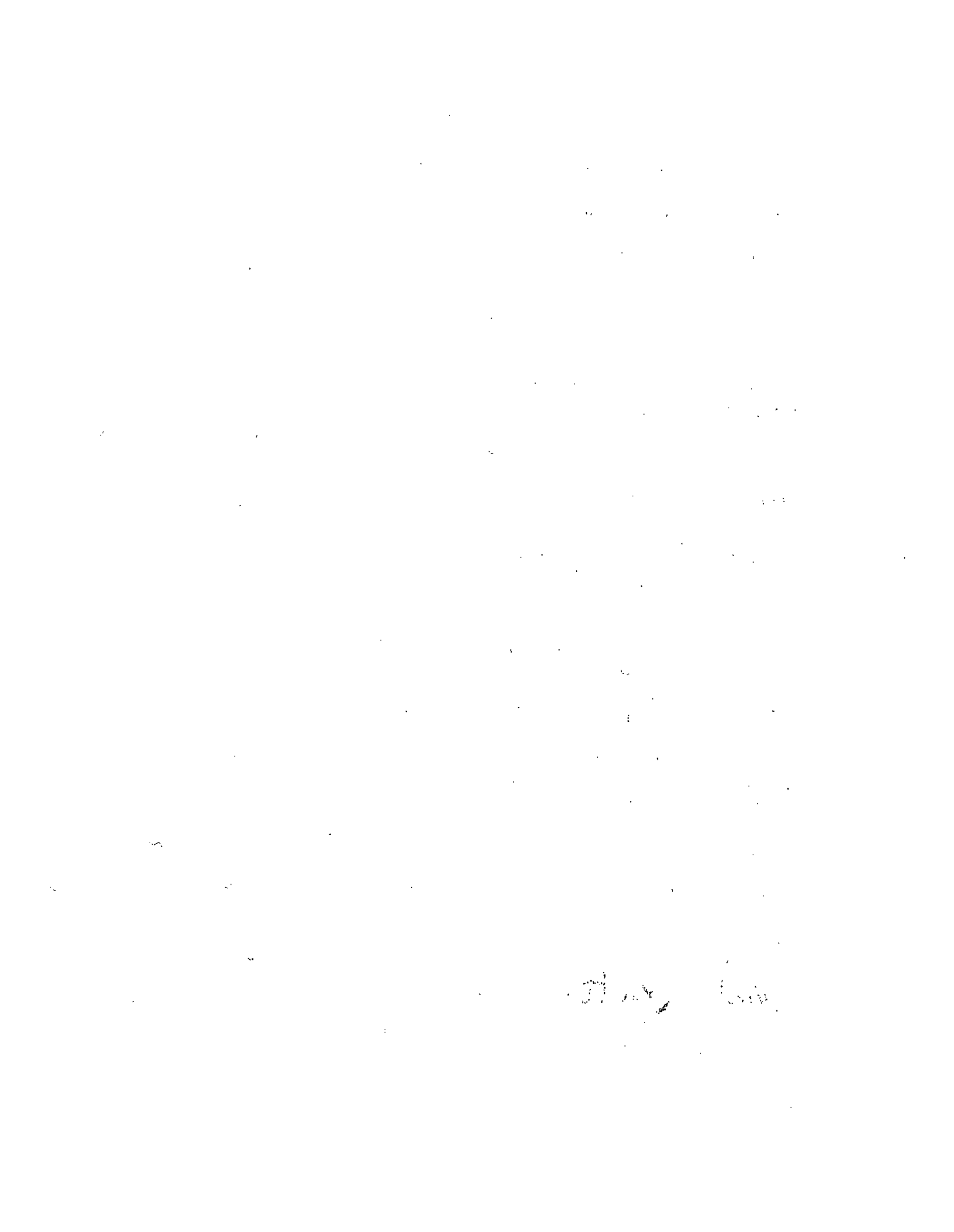

City of Chicago



R2014-351

Office of the City Clerk

Document Tracking Sheet

Meeting Date: 5/28/2014

Sponsor(s): Thompson (16)
Burnett (27)
Dowell (3)
Lane (18)
Austin (34)
Pawar (47)
Beale (9)
Reboyras (30)
Cochran (20)
O'Shea (19)

Type: Resolution

Title: Call for hearing(s) on methods and programs used to educate children, young adults and adults about dangers of violent responses to conflict

Committee(s) Assignment: Joint Committee: Education and Child Development; Health and Environmental Protection

R E S O L U T I O N

WHEREAS, the City of Chicago and other communities across the nation have been scarred by violence and the loss of young and innocent lives; and

WHEREAS, each year more than 5,000 youths between the ages of 15 and 24 die because of violence, making violence the second leading cause of death among this age group; and

WHEREAS, that disturbing statistic does not take into account the younger victims, some intended and some unintended, of violence; and

WHEREAS, according to news reports, many instances of violence against or by young people arise out of squabbles and disagreements that may appear petty or childish to outsiders, but carry great importance for those involved in the disputes; and

WHEREAS, the use by young people of social media, across various platforms, seems to inflate and accelerate these interpersonal conflicts; and

WHEREAS, there is a growing perception, whether accurate or not, that urban youth see violence as the only possible response to disagreement or conflict, and that they act without regard to consequence and without regard to the permanent effects of some of their actions; and

WHEREAS, some adults seem incapable of understanding or dealing with the problems and conflicts affecting youth under their care, while other adults seem to encourage extreme responses; and

WHEREAS, more than enough families have been broken, and more than enough lives shattered, for our society to come to the realization that new approaches must be devised to divert young people away from violence; and

WHEREAS, the U.S. Centers for Disease Control and Prevention (CDC) now recognizes violence as a public health issue and is working to develop educational programs to mitigate and reduce this public health crisis; and

WHEREAS, educational programs have been devised – and have proven effective – to increase the safety of young people by educating them about the dangers of tobacco use, of alcohol and drug use, of unsafe driving practices, of unsafe sex and HIV/AIDS; and

WHEREAS, youth and adults – especially those in charge of raising young people – need to be educated in how to promote safety, especially the safety of the most vulnerable; and

WHEREAS, effective education can and must begin even before compulsory school age: pre-schoolers can be prepared so that they begin school ready to learn, including ready to learn how to promote safety; and

WHEREAS, study after study has shown that early education can have life-long beneficial effects, and thus it is time to apply early education in a manner that can positively affect our youngest by helping them learn alternatives to violent responses; and

WHEREAS, it is only through the development and wide-spread application of educational programs, appropriate to age and developmental stage of recipients, that our society can change expectations about and responses to conflict and danger; and

WHEREAS, Mothers Against Senseless Killing (MASK), an organization of those affected by violence, has proposed development of educational programs, to be incorporated into mandatory school curricula, to educate children in ways to avoid the dangers of unsafe weapons use and in ways to resolve conflict without resort to violence; therefore,

BE IT RESOLVED that we, the Mayor and members of the City Council of the City of Chicago, assembled this 28th day of May, 2014, do hereby join Mothers Against Senseless Killing in calling on the Illinois General Assembly and the United States Congress to enact legislation aimed at protecting our young people by mandating development of age-appropriate and developmental stage-appropriate education programs, and incorporation of such programs into educational curricula from pre-school through grade 12; and

BE IT FURTHER RESOLVED that the City Council through a special joint committee consisting of the Committee on Education and Childhood Development and the Committee on Health and Environmental Protection conduct hearings into methods and programs for educating children, young adults and adults about the dangers of violent response to conflict; and

BE IT FURTHER RESOLVED that the special joint committee invite and take testimony from interested and informed individuals and organizations and individuals to assist in dealing with this health crisis; and

BE IT FURTHER RESOLVED that suitable copies of this Resolution be presented to the clerks and leadership of the Illinois Senate and the Illinois House of Representatives, and to the Illinois delegations to the United States Congress.



Alderman, 16th Ward

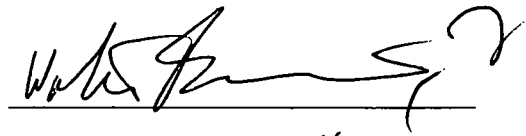

Alderman, 27th Ward

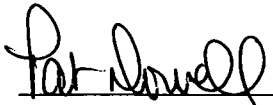

Alderman, 3rd Ward



Alderman, 18th Ward

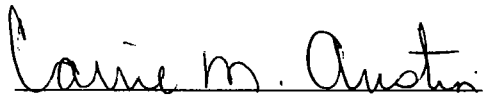

Alderman, 34th Ward

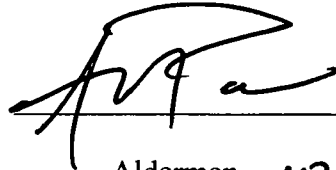

Alderman, 47 Ward



Alderman, 9th Ward



Alderman, 30 Ward

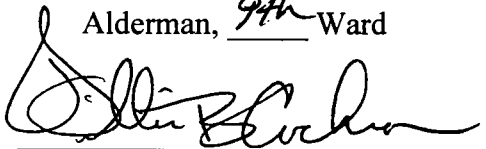

Alderman, 20th Ward

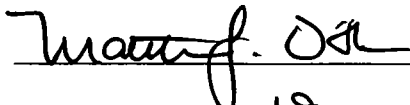

Alderman, 19 Ward



City of Chicago



R2014-358

Office of the City Clerk

Document Tracking Sheet

Meeting Date: 5/28/2014

Sponsor(s): Thomas (17)
Austin (34)
Burnett (27)
Ervin (28)
Graham (29)
Mitts (37)
Cochran (20)
Chandler (24)
Lane (18)
Holmes (7)
Brookins (21)
Harris (8)
Sawyer (6)
Dowell (3)
Beale (9)
Foulkes (15)
Thompson (16)

Type: Resolution

Title: Chicago Board of Education, Community College District No. 508, Chicago Park District, Chicago Transit Authority, and Chicago Housing Authority urged to adopt diversity in non-minority owned firms disclosure requirements

Committee(s) Assignment: Committee on Finance

Rhume

FINANCE

RESOLUTION

WHEREAS, this City Council now has under consideration an ordinance entitled the Diversity in Non-Minority-Owned Firms Disclosure Ordinance; and

WHEREAS, the purpose of that ordinance is to document whether non-minority-owned and controlled professional service firms involved in discretionary city transactions are availing themselves of the talents of members of minority groups and fostering their professional development; and

WHEREAS, it is the opinion of this City Council that all governmental bodies serving the people of the City of Chicago should adopt similar policies; now, therefore,

BE IT RESOLVED that we, the Mayor and members of the City Council of the City of Chicago, assembled this 28 day of MAY, 2014 do hereby encourage the respective governing bodies of the Board of Education of the City of Chicago, Community College District No. 508, the Chicago Park District, the Chicago transit Authority and the Chicago Housing Authority to adopt, in the appropriate form, and to enforce procedures and reporting requirements equal to those contained in the Diversity in Non-Minority-Owned Firms Disclosure Ordinance; and

BE IT FURTHER RESOLVED that suitable copies of this Resolution be presented to the secretaries or clerks of the above named governmental agencies.

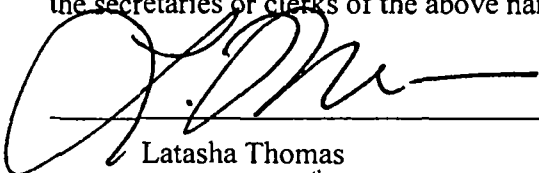

Latasha Thomas
Alderman, 17th Ward

Coryn M. Austin 34
Walter 27th

 37th

Emma Mills
Bill Bluch

Michael D. Clark 24
Lona Lane 18th

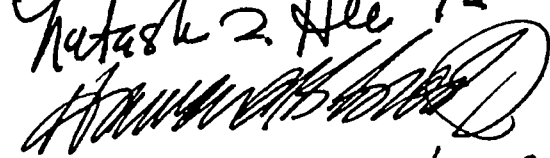
Natasha 2 Hill 7th

Michelle Adams 8th
Paul 5 (6)

Pat Dawell, 3rd

Cheryl Albers 9th
15

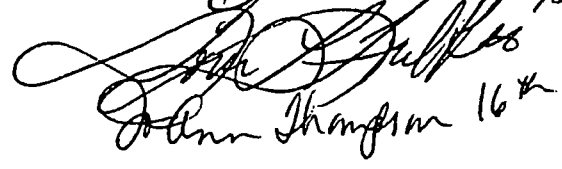
 16th



City of Chicago



O2014-4278

Office of the City Clerk

Document Tracking Sheet

| | |
|---------------------------------|--|
| Meeting Date: | 5/28/2014 |
| Sponsor(s): | Moreno (1) |
| Type: | Ordinance |
| Title: | Grant(s) of privilege in public way for Artemio's Bakery No. 2 |
| Committee(s) Assignment: | Committee on Transportation and Public Way |

ORDINANCE
ARTEMIO'S BAKERY #2
Acct. No. 6600 - 3
Permit No. 1112962

Be It Ordained by the City Council of the City of Chicago:

SECTION 1. Permission and authority are hereby given and granted to ARTEMIO'S BAKERY #2, upon the terms and subject to the conditions of this ordinance to maintain and use one (1) sign(s) projecting over the public right-of-way attached to its premises known as 1443 N. Milwaukee Ave..

Said sign structure(s) measures as follows; along N MILWAUKEE AVE:

One (1) at four point three three (4.33) feet in length, three (3) feet in height and ten point five eight (10.58) feet above grade level.

The location of said privilege shall be as shown on prints kept on file with the Department of Business Affairs and Consumer Protection and the Office of the City Clerk.

Said privilege shall be constructed in accordance with plans and specifications approved by the Department of Transportation (Division of Project Development) and Zoning Department - Signs.

This grant of privilege in the public way shall be subject to the provisions of Section 10-28-015 and all other required provisions of the Municipal Code of Chicago.

The grantee shall pay to the City of Chicago as compensation for the privilege #1112962 herein granted the sum of one hundred (\$100.00) per annum in advance.

A 25% penalty will be added for payments received after due date.

The permit holder agrees to hold the City of Chicago harmless for any damage, relocation or replacement costs associated with damage, relocation or removal of private property caused by the City performing work in the public way.

Authority herein given and granted for a period of five (5) years from and after 05/13/2014.

Alderman _____



Proco Joe Moreno 1st Ward





05/28/2014

Alderman **Proco Joe Moreno**
Ward # **01**
City of Chicago
City Hall, Room **300**
121 North LaSalle Street
Chicago, Illinois 60602

Re: An ordinance to use and maintain a portion of the public right-of-way for **one (1) sign(s)** for
ARTEMIO'S BAKERY #2, adjacent to the premises known as **1443 N. Milwaukee Ave.**.

Dear Alderman **Proco Joe Moreno**:

The applicant referenced above has requested the use of the public right-of-way for a **sign(s)**. An ordinance has been prepared by the Department of Business Affairs and Consumer Protection – Small Business Center - Public Way Use Unit for presentation to the City Council. Because this request was made for properties located in your ward, as approved by you as per the attached, I respectfully request that you introduce the attached ordinance at the next City Council meeting.

If you have any questions regarding this ordinance, please contact Anthony Bertuca at (312) 744-5506.

Department of Business Affairs and Consumer Protection



City of Chicago



O2014-4284

Office of the City Clerk

Document Tracking Sheet

| | |
|---------------------------------|--|
| Meeting Date: | 5/28/2014 |
| Sponsor(s): | Moreno (1) |
| Type: | Ordinance |
| Title: | Grant(s) of privilege in public way for Ashland & Division Currency |
| Committee(s) Assignment: | Committee on Transportation and Public Way |

ORDINANCE
ASHLAND & DIVISION CURRENCY
Acct. No. 48097 - 2
Permit No. 1112943

Be It Ordained by the City Council of the City of Chicago:

SECTION 1. Permission and authority are hereby given and granted to ASHLAND & DIVISION CURRENCY, upon the terms and subject to the conditions of this ordinance to maintain and use one (1) sign(s) projecting over the public right-of-way attached to its premises known as 1545 W. Division St..

Said sign structure(s) measures as follows; along W Division St.:

One (1) at eight (8) feet in length, ten (10) feet in height and twelve (12) feet above grade level.

The location of said privilege shall be as shown on prints kept on file with the Department of Business Affairs and Consumer Protection and the Office of the City Clerk.

Said privilege shall be constructed in accordance with plans and specifications approved by the Department of Transportation (Division of Project Development) and Zoning Department - Signs.

This grant of privilege in the public way shall be subject to the provisions of Section 10-28-015 and all other required provisions of the Municipal Code of Chicago.

The grantee shall pay to the City of Chicago as compensation for the privilege #1112943 herein granted the sum of three hundred (\$300.00) per annum in advance.

A 25% penalty will be added for payments received after due date.

The permit holder agrees to hold the City of Chicago harmless for any damage, relocation or replacement costs associated with damage, relocation or removal of private property caused by the City performing work in the public way.

Authority herein given and granted for a period of five (5) years from and after 11/19/2013.

Alderman _____

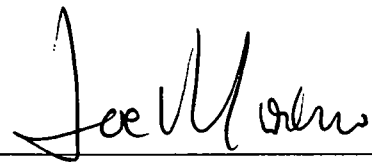

Proco Joe Moreno 1st Ward

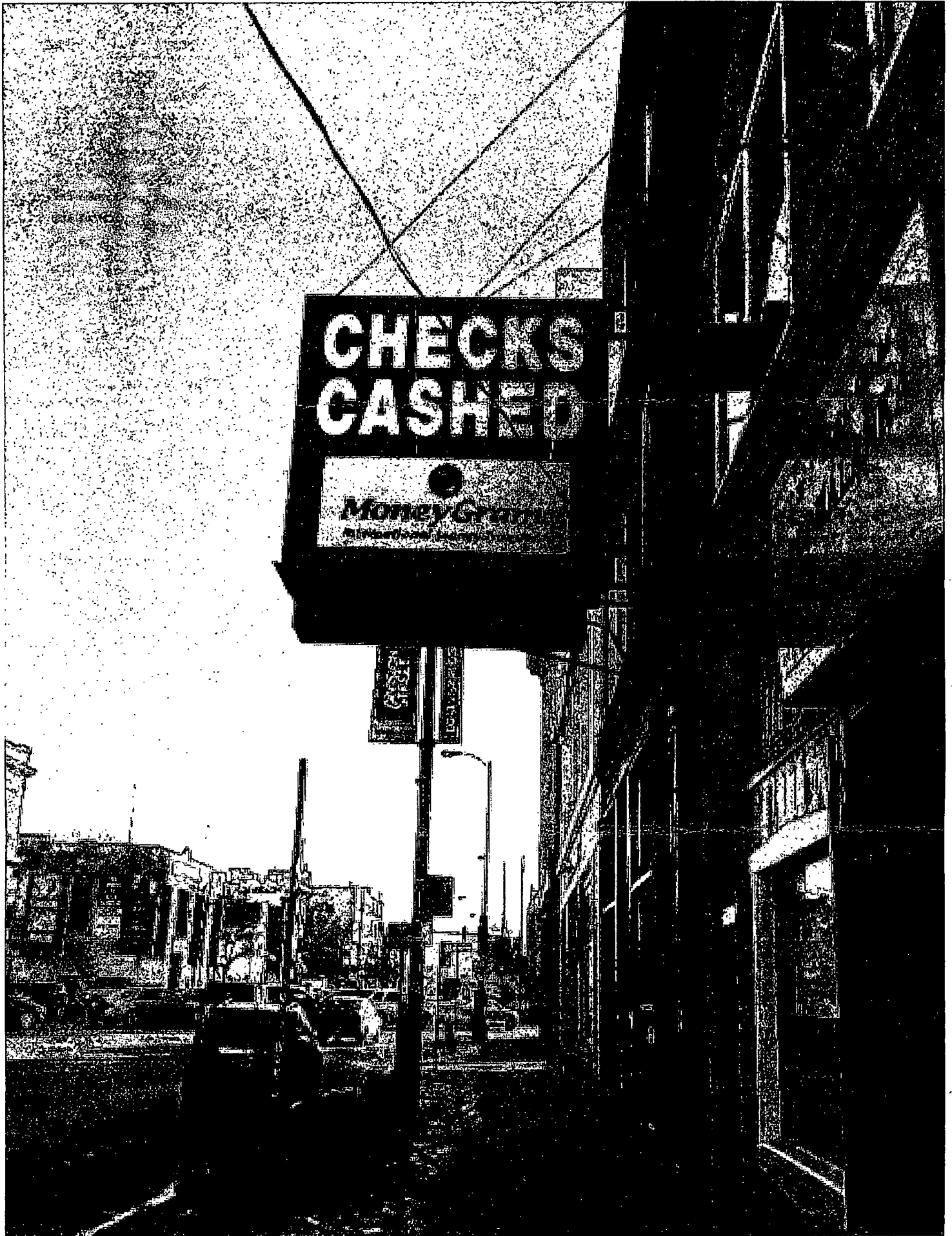



05/28/2014

Alderman **Proco Joe Moreno**
Ward # **01**
City of Chicago
City Hall, Room **300**
121 North LaSalle Street
Chicago, Illinois 60602

Re: An ordinance to use and maintain a portion of the public right-of-way for **one (1) sign(s)** for
ASHLAND & DIVISION CURRENCY, adjacent to the premises known as **1545 W. Division St.**

Dear Alderman **Proco Joe Moreno**:

The applicant referenced above has requested the use of the public right-of-way for a **sign(s)**. An ordinance has been prepared by the Department of Business Affairs and Consumer Protection – Small Business Center - Public Way Use Unit for presentation to the City Council. Because this request was made for properties located in your ward, as approved by you as per the attached, I respectfully request that you introduce the attached ordinance at the next City Council meeting.

If you have any questions regarding this ordinance, please contact Anthony Bertuca at (312) 744-5506.

Department of Business Affairs and Consumer Protection



City of Chicago



O2014-4287

Office of the City Clerk

Document Tracking Sheet

| | |
|---------------------------------|--|
| Meeting Date: | 5/28/2014 |
| Sponsor(s): | Moreno (1) |
| Type: | Ordinance |
| Title: | Grant(s) of privilege in public way for Bartosz Wisniewski |
| Committee(s) Assignment: | Committee on Transportation and Public Way |

ORDINANCE
BARTOSZ WISNIEWSKI
Acct. No. 375785 - 1
Permit No. 1112440

Be It Ordained by the City Council of the City of Chicago:

SECTION 1. Permission and authority are hereby given and granted to BARTOSZ WISNIEWSKI, upon the terms and subject to the conditions of this ordinance to maintain and use, as now constructed, Occupation of Space under the public right-of-way adjacent to its premises known as 1343 N. Bosworth Ave..

Said Occupation of Space at N. Bosworth Avenue measure(s):

One (1) at fourteen (14) feet in length, and three (3) feet in width for a total of forty-two (42) square feet. Existing occupation of space is below grade level in front of residential building.

The location of said privilege shall be as shown on prints kept on file with the Department of Business Affairs and Consumer Protection and the Office of the City Clerk.

Said privilege shall be constructed in accordance with plans and specifications approved by the Department of Planning and Development, Department of Transportation (Division of Project Development), and Department of Transportation (Office of Underground Coordination).

This grant of privilege in the public way shall be subject to the provisions of Section 10-28-015 and all other required provisions of the Municipal Code of Chicago.

The grantee shall pay to the City of Chicago as compensation for the privilege #1112440 herein granted the sum of four hundred (\$400.00) per annum in advance.

A 25% penalty will be added for payments received after due date.

The permit holder agrees to hold the City of Chicago harmless for any damage, relocation or replacement costs associated with damage, relocation or removal of private property caused by the City performing work in the public way.

Authority herein given and granted for a period of five (5) years from and after Date of Passage.

Alderman _____



Proco Joe Moreno 1st Ward

USE OF THE PUBLIC WAY APPLICATION



NAME: BARTOSZ & EVELYN WISNIEWSKI

ADDRESS: 1343 N BOSWORTH AVE

CHICAGO, IL 60642

TYPE: STAIR & FENCE AT EXISTING RESIDENTIAL BUILDING, CONSTRUCTED PRIOR TO 1923 AS DEFINED 17-11-02146.

N. BOSWORTH AVE.

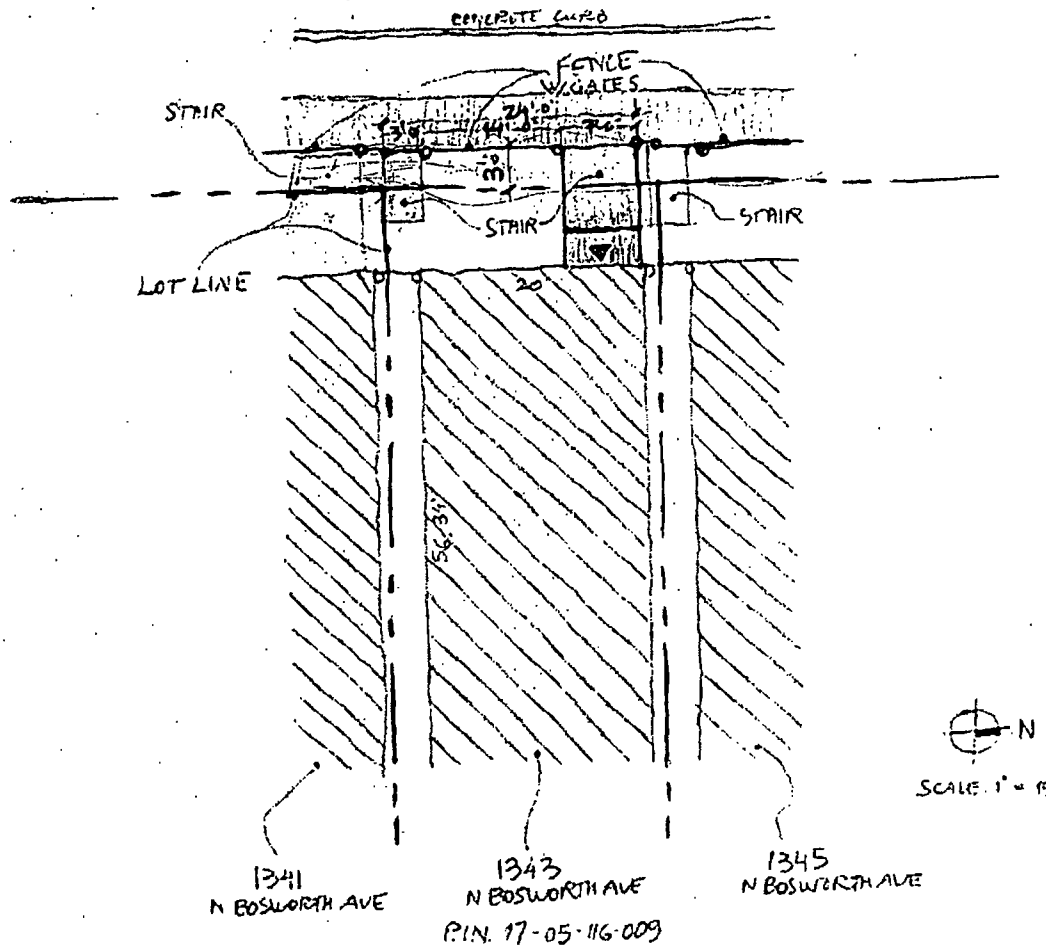



05/28/2014

Alderman Proco Joe Moreno
Ward # 01
City of Chicago
City Hall, Room 300
121 North LaSalle Street
Chicago, Illinois 60602

Re: An ordinance to use and maintain a portion of the public right-of-way for **one (1) occupation of space(s)** for **BARTOSZ WISNIEWSKI**, adjacent to the premises known as **1343 N. Bosworth Ave.**

Dear Alderman Proco Joe Moreno:

The applicant referenced above has requested the use of the public right-of-way for a **occupation of space(s)**. An ordinance has been prepared by the Department of Business Affairs and Consumer Protection – Small Business Center - Public Way Use Unit for presentation to the City Council. Because this request was made for properties located in your ward, as approved by you as per the attached, I respectfully request that you introduce the attached ordinance at the next City Council meeting.

If you have any questions regarding this ordinance, please contact Anthony Bertuca at (312) 744-5506.

Department of Business Affairs and Consumer Protection



City of Chicago



O2014-4298

Office of the City Clerk

Document Tracking Sheet

| | |
|---------------------------------|---|
| Meeting Date: | 5/28/2014 |
| Sponsor(s): | Moreno (1) |
| Type: | Ordinance |
| Title: | Grant(s) of privilege in public way for Delta Animal Hospital |
| Committee(s) Assignment: | <i>Committee on Transportation and Public Way</i> |

ORDINANCE
DELTA ANIMAL HOSPITAL
Acct. No. 24952 - 1
Permit No. 1113095

Be It Ordained by the City Council of the City of Chicago:

SECTION 1. Permission and authority are hereby given and granted to DELTA ANIMAL HOSPITAL, upon the terms and subject to the conditions of this ordinance to maintain and use one (1) sign(s) projecting over the public right-of-way attached to its premises known as 2105 W. Chicago Ave..

Said sign structure(s) measures as follows; along W. CHICAGO AVE.:

One (1) at four (4) feet in length, four (4) feet in height and nine (9) feet above grade level.

The location of said privilege shall be as shown on prints kept on file with the Department of Business Affairs and Consumer Protection and the Office of the City Clerk.

Said privilege shall be constructed in accordance with plans and specifications approved by the Department of Transportation (Division of Project Development) and Zoning Department - Signs.

This grant of privilege in the public way shall be subject to the provisions of Section 10-28-015 and all other required provisions of the Municipal Code of Chicago.

The grantee shall pay to the City of Chicago as compensation for the privilege #1113095 herein granted the sum of one hundred (\$100.00) per annum in advance.

A 25% penalty will be added for payments received after due date.

The permit holder agrees to hold the City of Chicago harmless for any damage, relocation or replacement costs associated with damage, relocation or removal of private property caused by the City performing work in the public way.

Authority herein given and granted for a period of five (5) years from and after 05/13/2014.

Alderman _____



Proco Joe Moreno 1st Ward

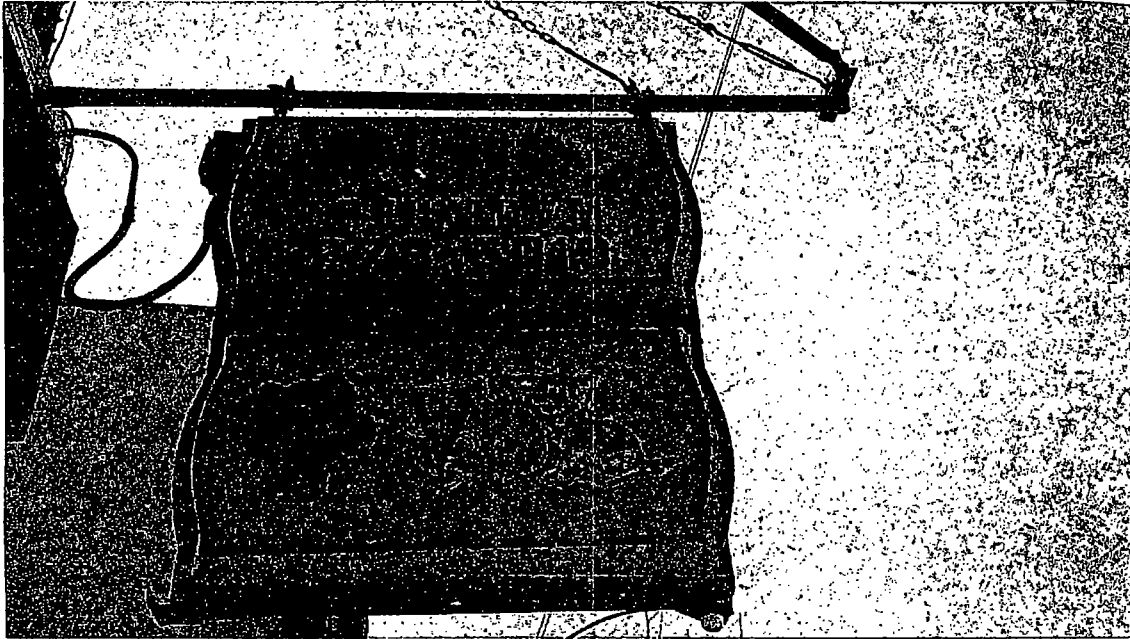



05/28/2014

Alderman **Proco Joe Moreno**
Ward # **01**
City of Chicago
City Hall, Room **300**
121 North LaSalle Street
Chicago, Illinois 60602

Re: An ordinance to use and maintain a portion of the public right-of-way for **one (1) sign(s)** for **DELTA ANIMAL HOSPITAL**, adjacent to the premises known as **2105 W. Chicago Ave.**.

Dear Alderman **Proco Joe Moreno**:

The applicant referenced above has requested the use of the public right-of-way for a **sign(s)**. An ordinance has been prepared by the Department of Business Affairs and Consumer Protection – Small Business Center - Public Way Use Unit for presentation to the City Council. Because this request was made for properties located in your ward, as approved by you as per the attached, I respectfully request that you introduce the attached ordinance at the next City Council meeting.

If you have any questions regarding this ordinance, please contact Anthony Bertuca at (312) 744-5506.

Department of Business Affairs and Consumer Protection



City of Chicago



O2014-4299

Office of the City Clerk

Document Tracking Sheet

| | |
|---------------------------------|---|
| Meeting Date: | 5/28/2014 |
| Sponsor(s): | Moreno (1) |
| Type: | Ordinance |
| Title: | Grant(s) of privilege in public way for Gold Star Bar, Inc. |
| Committee(s) Assignment: | Committee on Transportation and Public Way |

ORDINANCE
GOLD STAR BAR INC
Acct. No. 32810 - 2
Permit No. 1113025

Be It Ordained by the City Council of the City of Chicago:

SECTION 1. Permission and authority are hereby given and granted to GOLD STAR BAR INC, upon the terms and subject to the conditions of this ordinance to maintain and use one (1) sign(s) projecting over the public right-of-way attached to its premises known as 1755 W. Division St..

Said sign structure(s) measures as follows; along W. DIVISION:
One (1) at four (4) feet in length, fourteen (14) feet in height and sixteen (16) feet above grade level.

The location of said privilege shall be as shown on prints kept on file with the Department of Business Affairs and Consumer Protection and the Office of the City Clerk.

Said privilege shall be constructed in accordance with plans and specifications approved by the Department of Transportation (Division of Project Development) and Zoning Department - Signs.

This grant of privilege in the public way shall be subject to the provisions of Section 10-28-015 and all other required provisions of the Municipal Code of Chicago.

The grantee shall pay to the City of Chicago as compensation for the privilege #1113025 herein granted the sum of three hundred (\$300.00) per annum in advance.

A 25% penalty will be added for payments received after due date.

The permit holder agrees to hold the City of Chicago harmless for any damage, relocation or replacement costs associated with damage, relocation or removal of private property caused by the City performing work in the public way.

Authority herein given and granted for a period of five (5) years from and after 04/22/2014.

Alderman _____

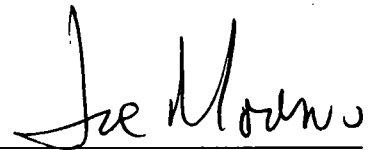

Proco Joe Moreno 1st Ward





Department of Business Affairs and Consumer Protection
Small Business Center - Public Way Use Unit
City Hall - 121 N. LaSalle Street, Room 800 • Chicago, IL 60602
(312)-74-GOBIZ (312-744-6249) • (312) 744-1944 (TTY)
<http://www.cityofchicago.org/bacp>

05/28/2014

Alderman **Proco Joe Moreno**
Ward # **01**
City of Chicago
City Hall, Room **300**
121 North LaSalle Street
Chicago, Illinois 60602

Re: An ordinance to use and maintain a portion of the public right-of-way for **one (1) sign(s)** for **GOLD STAR BAR INC**, adjacent to the premises known as **1755 W. Division St.**

Dear Alderman **Proco Joe Moreno**:

The applicant referenced above has requested the use of the public right-of-way for a **sign(s)**. An ordinance has been prepared by the Department of Business Affairs and Consumer Protection – Small Business Center - Public Way Use Unit for presentation to the City Council. Because this request was made for properties located in your ward, as approved by you as per the attached, I respectfully request that you introduce the attached ordinance at the next City Council meeting.

If you have any questions regarding this ordinance, please contact Anthony Bertuca at (312) 744-5506.

Department of Business Affairs and Consumer Protection



City of Chicago



O2014-4301

Office of the City Clerk

Document Tracking Sheet

| | |
|---------------------------------|---|
| Meeting Date: | 5/28/2014 |
| Sponsor(s): | Moreno (1) |
| Type: | Ordinance |
| Title: | Grant(s) of privilege in public way for Hollywood Grill |
| Committee(s) Assignment: | Committee on Transportation and Public Way |

ORDINANCE
HOLLYWOOD GRILL
Acct. No. 16463 - 1
Permit No. 1113127

Be It Ordained by the City Council of the City of Chicago:

SECTION 1. Permission and authority are hereby given and granted to HOLLYWOOD GRILL, upon the terms and subject to the conditions of this ordinance to maintain and use five (5) sign(s) projecting over the public right-of-way attached to its premises known as 1601 W. North Ave..

Said sign structure(s) measures as follows; along N. ASHLAND:

One (1) at thirty (30) feet in length, two (2) feet in height and ten (10) feet above grade level.

Said sign structure(s) measures as follows; along N. ASHLAND:

One (1) at seven (7) feet in length, one (1) foot in height and nine (9) feet above grade level.

Said sign structure(s) measures as follows; along W. NORTH AVE.:

One (1) at three (3) feet in length, sixteen point five (16.5) feet in height and nine point six seven (9.67) feet above grade level.

Said sign structure(s) measures as follows; along W. NORTH AVE:

One (1) at twenty (20) feet in length, two (2) feet in height and one point six seven (1.67) feet above grade level.

Said sign structure(s) measures as follows; along W. NORTH AVE.:

One (1) at seven (7) feet in length, one (1) foot in height and nine point six seven (9.67) feet above grade level.

The location of said privilege shall be as shown on prints kept on file with the Department of Business Affairs and Consumer Protection and the Office of the City Clerk.

Said privilege shall be constructed in accordance with plans and specifications approved by the Department of Transportation (Division of Project Development) and Zoning Department - Signs.

This grant of privilege in the public way shall be subject to the provisions of Section 10-28-015 and all other required provisions of the Municipal Code of Chicago.

The grantee shall pay to the City of Chicago as compensation for the privilege #1113127 herein granted the sum of one thousand seventy-five (\$1,075.00) per annum in advance.

A 25% penalty will be added for payments received after due date.

The permit holder agrees to hold the City of Chicago harmless for any damage, relocation or replacement costs associated with damage, relocation or removal of private property caused by the City performing work in the public way.

Authority herein given and granted for a period of five (5) years from and after 05/13/2014.

Alderman _____

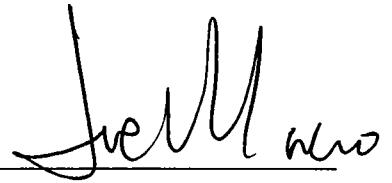
A handwritten signature in black ink, appearing to read "Joe Moreno". The signature is written in a cursive style with a large initial "J" and "M".

Proco Joe Moreno 1st Ward

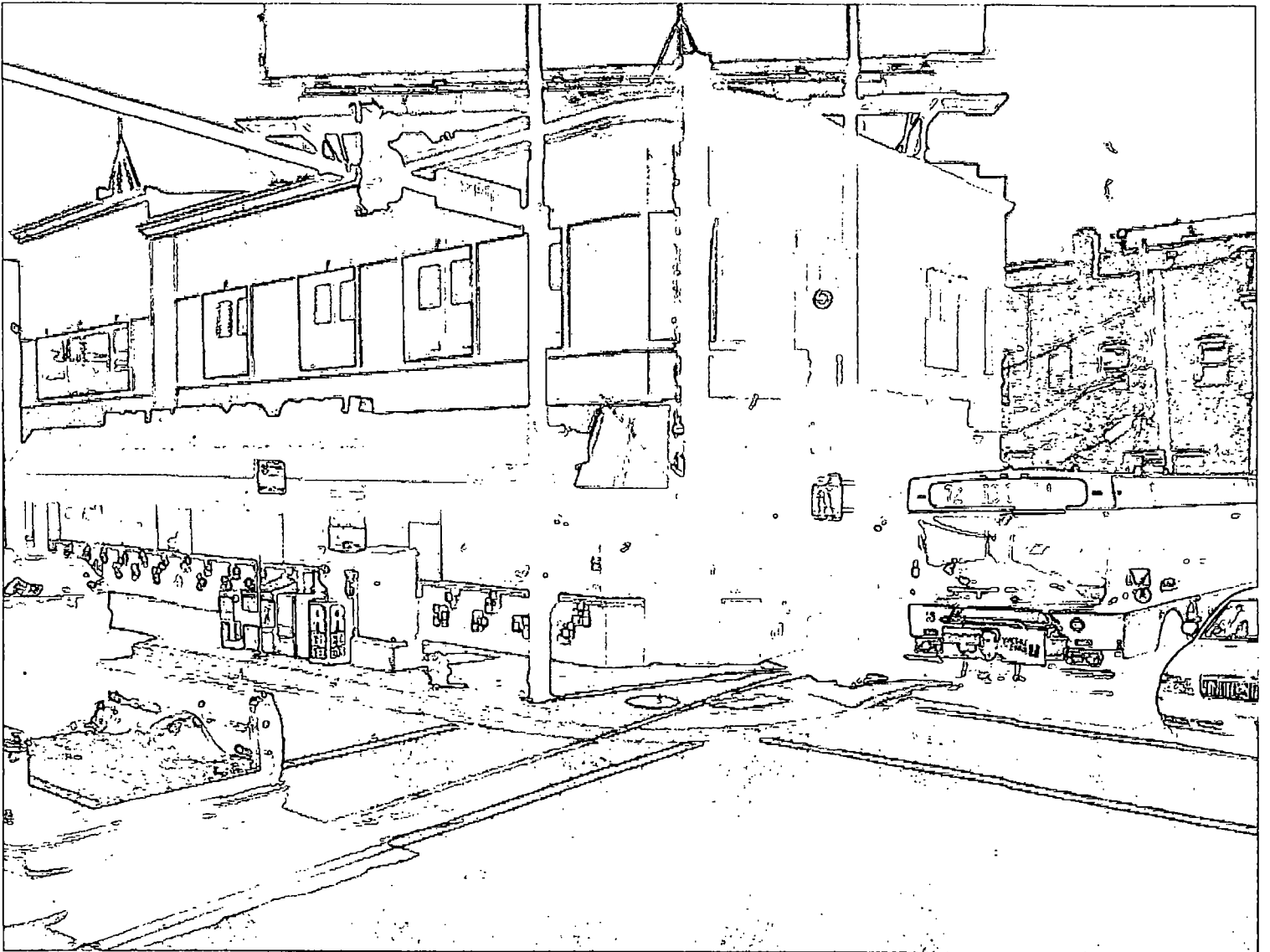



05/28/2014

Alderman **Proco Joe Moreno**
Ward # **01**
City of Chicago
City Hall, Room **300**
121 North LaSalle Street
Chicago, Illinois 60602

Re: An ordinance to use and maintain a portion of the public right-of-way for **five (5) sign(s)** for
HOLLYWOOD GRILL, adjacent to the premises known as **1601 W. North Ave.**.

Dear Alderman **Proco Joe Moreno**:

The applicant referenced above has requested the use of the public right-of-way for a **sign(s)**. An ordinance has been prepared by the Department of Business Affairs and Consumer Protection – Small Business Center - Public Way Use Unit for presentation to the City Council. Because this request was made for properties located in your ward, as approved by you as per the attached, I respectfully request that you introduce the attached ordinance at the next City Council meeting.

If you have any questions regarding this ordinance, please contact Anthony Bertuca at (312) 744-5506.

Department of Business Affairs and Consumer Protection



City of Chicago



O2014-4309

Office of the City Clerk

Document Tracking Sheet

| | |
|---------------------------------|---|
| Meeting Date: | 5/28/2014 |
| Sponsor(s): | Moreno (1) |
| Type: | Ordinance |
| Title: | Grant(s) of privilege in public way for Mariano's No. 8527 Ukrainian Village |
| Committee(s) Assignment: | Committee on Transportation and Public Way |

ORDINANCE
MARIANO'S #8527 UKRANIAN VILLAGE
Acct. No. 360006 - 7
Permit No. 1111011

Be It Ordained by the City Council of the City of Chicago:

SECTION 1. Permission and authority are hereby given and granted to MARIANO'S #8527 UKRANIAN VILLAGE, upon the terms and subject to the conditions of this ordinance to maintain and use one (1) sign(s) projecting over the public right-of-way attached to its premises known as 2021 W. Chicago Ave..

Said sign structure(s) measures as follows; along W. Chicago Avenue:

One (1) at nineteen point four two (19.42) feet in length, eight point five (8.5) feet in height and twenty-four (24) feet above grade level.

The location of said privilege shall be as shown on prints kept on file with the Department of Business Affairs and Consumer Protection and the Office of the City Clerk.

Said privilege shall be constructed in accordance with plans and specifications approved by the Department of Transportation (Division of Project Development) and Zoning Department - Signs.

This grant of privilege in the public way shall be subject to the provisions of Section 10-28-015 and all other required provisions of the Municipal Code of Chicago.

The grantee shall pay to the City of Chicago as compensation for the privilege #1111011 herein granted the sum of three hundred (\$300.00) per annum in advance.

A 25% penalty will be added for payments received after due date.

The permit holder agrees to hold the City of Chicago harmless for any damage, relocation or replacement costs associated with damage, relocation or removal of private property caused by the City performing work in the public way.

Authority herein given and granted for a period of five (5) years from and after Date of Passage.

Alderman _____



Proco Joe Moreno 1st Ward

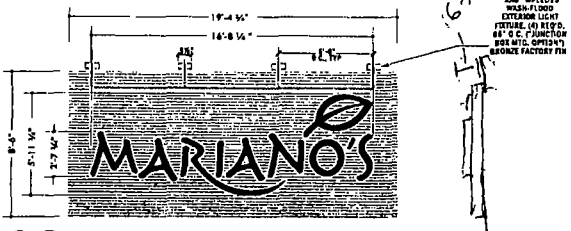

SAB W/LED'S
 W/AN-FLOOD
 EXTERIOR LIGHT
 FIXTURE. (4) REG. 6\"/>

B1 B2 REPLACE EXISTING "DOMINICK'S" CHANNEL LETTERS WITH NEW MARIANO'S LOGO PANEL
 SCALE: 3/16"=1"

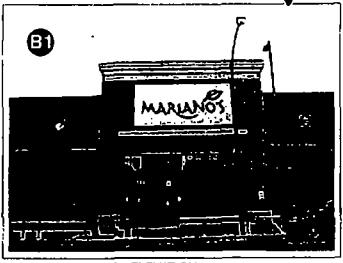

B1 PROPOSED NORTH ELEVATION

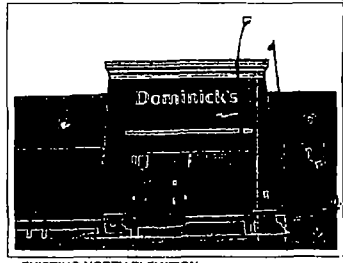

B2 EXISTING NORTH ELEVATION

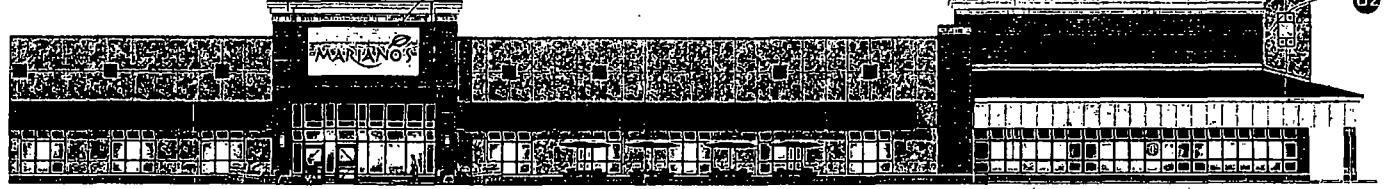

PROPOSED PARTIAL NORTH ELEVATION
 SCALE: 1/16"=1"

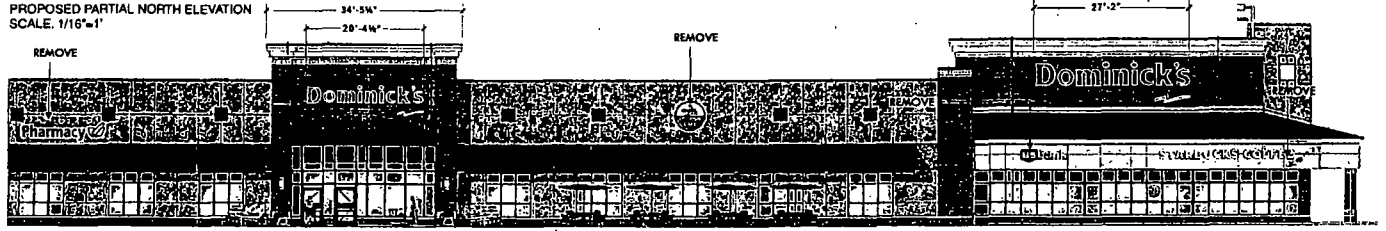

EXISTING PARTIAL NORTH ELEVATION
 SCALE: 1/16"=1"

DOLE
 GENERAL SIGN CONTRACTORS
 888 INTERSTATE RD. P.O. BOX 1700 ADDISON, IL 60101 TEL: 630-640-6000 FAX: 630-640-6003

| DATE | REVISION |
|------|----------|
| | |
| | |
| | |
| | |

CUSTOMER APPROVAL _____ **DATE** _____

This design is the original and unpublished work of DOYLE SIGNS INC. and may not be reproduced, copied or utilized in any fashion without the expressed written consent from an authorized officer of The Company. The right to this design may be purchased.

CLIENT MARIANO'S FRESH MARKET
ADDRESS CHICAGO & DAMEN
CITY CHICAGO **STATE** IL **DESIGNER AT** **SALESPERSON** TD
DRWG. NO. 13737 **SCALE** NOTED **DATE** 12.9.13 **SHEET NO.** 2 of 3
©DOYLE SIGNS INC. 2114 MARIANO'S SPRINGFIELD, ILLINOIS • CHICAGO & DAMEN • CHICAGO, ILLINOIS • CHICAGO & DAMEN • CHICAGO, ILLINOIS



05/28/2014

Alderman **Proco Joe Moreno**
Ward # **01**
City of Chicago
City Hall, Room **300**
121 North LaSalle Street
Chicago, Illinois 60602

Re: An ordinance to use and maintain a portion of the public right-of-way for **one (1) sign(s)** for **MARIANO'S #8527 UKRANIAN VILLAGE**, adjacent to the premises known as **2021 W. Chicago Ave.**.

Dear Alderman **Proco Joe Moreno**:

The applicant referenced above has requested the use of the public right-of-way for a **sign(s)**. An ordinance has been prepared by the Department of Business Affairs and Consumer Protection – Small Business Center - Public Way Use Unit for presentation to the City Council. Because this request was made for properties located in your ward, as approved by you as per the attached, I respectfully request that you introduce the attached ordinance at the next City Council meeting.

If you have any questions regarding this ordinance, please contact Anthony Bertuca at (312) 744-5506.

Department of Business Affairs and Consumer Protection



City of Chicago



O2014-4310

Office of the City Clerk

Document Tracking Sheet

| | |
|---------------------------------|---|
| Meeting Date: | 5/28/2014 |
| Sponsor(s): | Moreno (1) |
| Type: | Ordinance |
| Title: | Grant(s) of privilege in public way for Pet Supplies Plus |
| Committee(s) Assignment: | Committee on Transportation and Public Way |

ORDINANCE
PET SUPPLIES PLUS
Acct. No. 358107 - 4
Permit No. 1109644

Be It Ordained by the City Council of the City of Chicago:

SECTION 1. Permission and authority are hereby given and granted to PET SUPPLIES PLUS, upon the terms and subject to the conditions of this ordinance to maintain and use one (1) sign(s) projecting over the public right-of-way attached to its premises known as 1289 N. Milwaukee Ave..

Said sign structure(s) measures as follows; along N. Milwaukee Avenue:
One (1) at twenty-nine point nine two (29.92) feet in length, two point five eight (2.58) feet in height and eighteen (18) feet above grade level.

The location of said privilege shall be as shown on prints kept on file with the Department of Business Affairs and Consumer Protection and the Office of the City Clerk.

Said privilege shall be constructed in accordance with plans and specifications approved by the Department of Transportation (Division of Project Development) and Zoning Department - Signs.

This grant of privilege in the public way shall be subject to the provisions of Section 10-28-015 and all other required provisions of the Municipal Code of Chicago.

The grantee shall pay to the City of Chicago as compensation for the privilege #1109644 herein granted the sum of three hundred (\$300.00) per annum in advance.

A 25% penalty will be added for payments received after due date.

The permit holder agrees to hold the City of Chicago harmless for any damage, relocation or replacement costs associated with damage, relocation or removal of private property caused by the City performing work in the public way.

Authority herein given and granted for a period of five (5) years from and after Date of Passage.

Alderman _____



Proco Joe Moreno 1st Ward

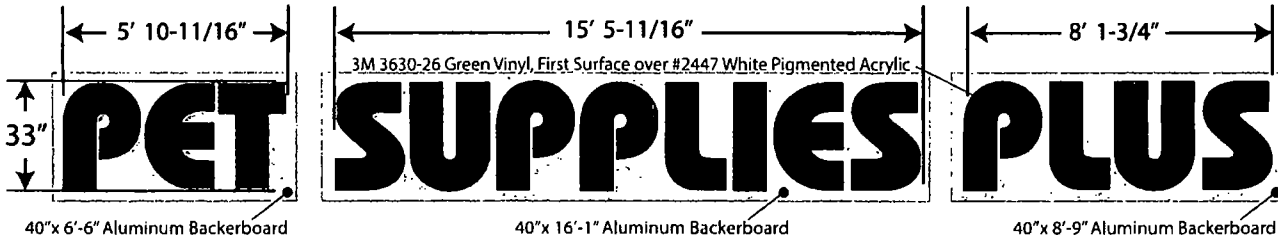

LED
Illuminat

Flat Pigmented Acrylic Faces with 3/4" Green Trim Caps & 5" Dark Bronze Aluminum Returns

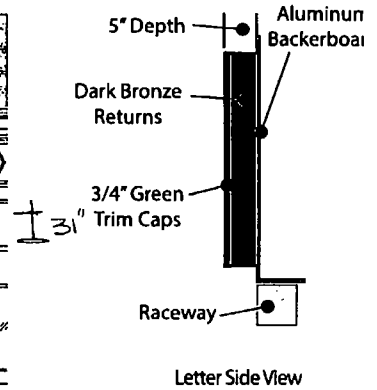
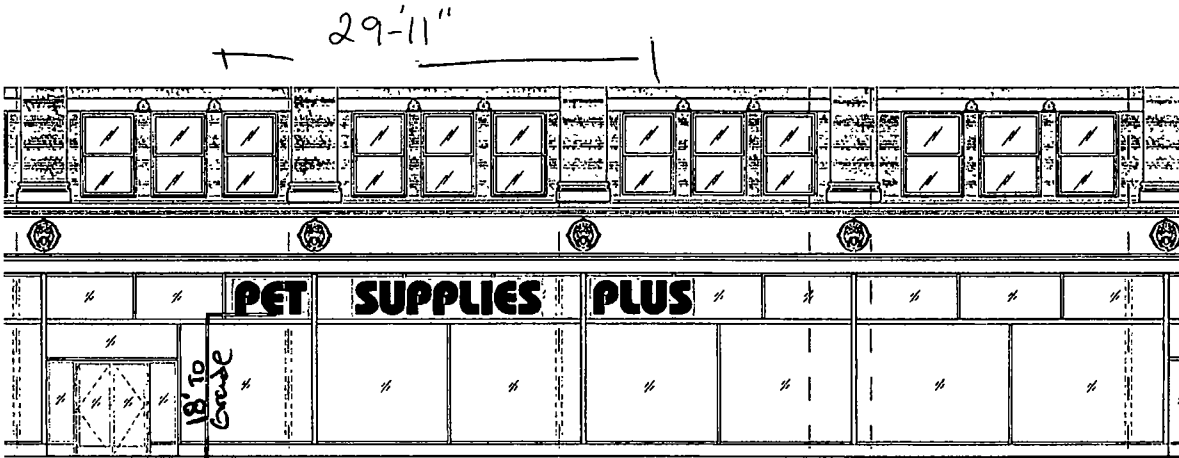

Everbrite DISCLAIMER: Renderings are for graphic purposes only and not intended for actual construction dimensions. For windload requirements, actual dimensions and mounting detail, please refer to engineering specifications and install drawings. These drawings and designs are the exclusive property of Everbrite LLC. Use of, or duplication in any manner without express written permission of Everbrite LLC is prohibited.

| | | | |
|-----------------------------|---------------------|---|--|
| Customer: Pet Supplies Plus | | Description: 33" LED Channel Letter Set w/ 3 Backerboards | Customer Approval: NOTE: Unless specified by customer, all depth of embossing will be determined by Everbrite Engineering or existing customer specifications on file. Colors and graphics on file will be used unless otherwise specified by customer. Please read carefully, check appropriate box and fax back to Everbrite: |
| Project No: 299959 | Scale: 1/4" = 1'-0" | | |
| Date: 8/22/13 | Drawn By: KW | Revised: | SIGNATURE _____ DATE _____ |
| Location: Chicago, IL | Site No: PS1289ADR | Revised: | |



05/28/2014

Alderman **Proco Joe Moreno**
Ward # **01**
City of Chicago
City Hall, Room **300**
121 North LaSalle Street
Chicago, Illinois 60602

Re: An ordinance to use and maintain a portion of the public right-of-way for **one (1) sign(s)** for **PET SUPPLIES PLUS**, adjacent to the premises known as **1289 N. Milwaukee Ave.**.

Dear Alderman **Proco Joe Moreno**:

The applicant referenced above has requested the use of the public right-of-way for a **sign(s)**. An ordinance has been prepared by the Department of Business Affairs and Consumer Protection – Small Business Center - Public Way Use Unit for presentation to the City Council. Because this request was made for properties located in your ward, as approved by you as per the attached, I respectfully request that you introduce the attached ordinance at the next City Council meeting.

If you have any questions regarding this ordinance, please contact Anthony Bertuca at (312) 744-5506.

Department of Business Affairs and Consumer Protection



City of Chicago



O2014-4314

Office of the City Clerk

Document Tracking Sheet

| | |
|---------------------------------|--|
| Meeting Date: | 5/28/2014 |
| Sponsor(s): | Moreno (1) |
| Type: | Ordinance |
| Title: | Grant(s) of privilege in public way for Picante's Authentaco |
| Committee(s) Assignment: | Committee on Transportation and Public Way |

ORDINANCE
PICANTE'S AUTHENTACO
Acct. No. 388974 - 1
Permit No. 1112816

Be It Ordained by the City Council of the City of Chicago:

SECTION 1. Permission and authority are hereby given and granted to PICANTE'S AUTHENTACO, upon the terms and subject to the conditions of this ordinance to maintain and use, as now constructed, five (5) Light Fixture(s) projecting over the public right-of-way adjacent to its premises known as 1141 N. Ashland Ave..

Said Light Fixture(s) at N. Ashland Avenue measure(s):

Four (4) at two (2) feet in length, three (3) feet in width and thirteen (13) feet above grade level.

One (1) at two (2) feet in length, three (3) feet in width and seventeen (17) feet above grade level.

The location of said privilege shall be as shown on prints kept on file with the Department of Business Affairs and Consumer Protection and the Office of the City Clerk.

Said privilege shall be constructed in accordance with plans and specifications approved by the Department of Transportation (Division of Project Development).

This grant of privilege in the public way shall be subject to the provisions of Section 10-28-015 and all other required provisions of the Municipal Code of Chicago.

The grantee shall pay to the City of Chicago as compensation for the privilege #1112816 herein granted the sum of ninety-five (\$95.00) per annum in advance.

A 25% penalty will be added for payments received after due date.

The permit holder agrees to hold the City of Chicago harmless for any damage, relocation or replacement costs associated with damage, relocation or removal of private property caused by the City performing work in the public way.

Authority herein given and granted for a period of five (5) years from and after Date of Passage.

Alderman _____



Proco Joe Moreno 1st Ward

Picante's Authentaco

1141 N. Ashland

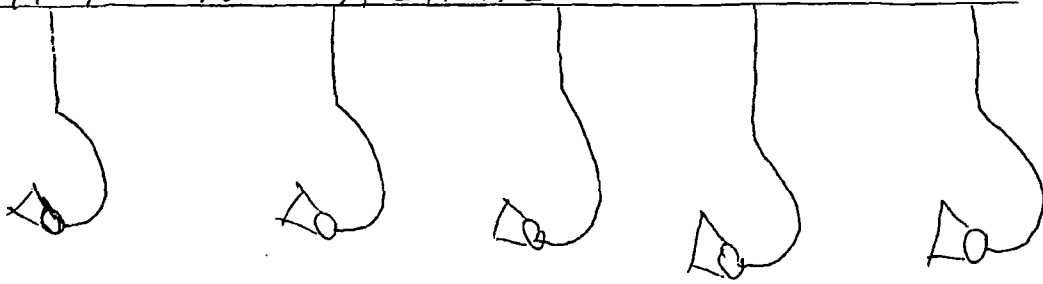

1
17 ft

1 Light
Above
GRADE

13 ft

Height
ABOVE
GRADE

8 inches

Width
of lights

3 ft

Depth
of
Lights



05/28/2014

Alderman **Proco Joe Moreno**
Ward # **01**
City of Chicago
City Hall, Room **300**
121 North LaSalle Street
Chicago, Illinois 60602

Re: An ordinance to use and maintain a portion of the public right-of-way for **five (5) light fixture(s)** for **PICANTE'S AUTHENTACO**, adjacent to the premises known as **1141 N. Ashland Ave.**.

Dear Alderman **Proco Joe Moreno**:

The applicant referenced above has requested the use of the public right-of-way for a **light fixture(s)**. An ordinance has been prepared by the Department of Business Affairs and Consumer Protection – Small Business Center - Public Way Use Unit for presentation to the City Council. Because this request was made for properties located in your ward, as approved by you as per the attached, I respectfully request that you introduce the attached ordinance at the next City Council meeting.

If you have any questions regarding this ordinance, please contact Anthony Bertuca at (312) 744-5506.

Department of Business Affairs and Consumer Protection



City of Chicago



O2014-4318

Office of the City Clerk

Document Tracking Sheet

| | |
|---------------------------------|---|
| Meeting Date: | 5/28/2014 |
| Sponsor(s): | Moreno (1) |
| Type: | Ordinance |
| Title: | Grant(s) of privilege in public way for Real Drugs, Inc |
| Committee(s) Assignment: | Committee on Transportation and Public Way |

ORDINANCE
REAL DRUGS INC
Acct. No. 28766 - 1
Permit No. 1113026

Be It Ordained by the City Council of the City of Chicago:

SECTION 1. Permission and authority are hereby given and granted to REAL DRUGS INC, upon the terms and subject to the conditions of this ordinance to maintain and use one (1) sign(s) projecting over the public right-of-way attached to its premises known as 1530 W. Chicago Ave..

Said sign structure(s) measures as follows; along W CHICAGO AVE:

One (1) at eight point three three (8.33) feet in length, four point six seven (4.67) feet in height and fourteen point eight three (14.83) feet above grade level.

The location of said privilege shall be as shown on prints kept on file with the Department of Business Affairs and Consumer Protection and the Office of the City Clerk.

Said privilege shall be constructed in accordance with plans and specifications approved by the Department of Transportation (Division of Project Development) and Zoning Department - Signs.

This grant of privilege in the public way shall be subject to the provisions of Section 10-28-015 and all other required provisions of the Municipal Code of Chicago.

The grantee shall pay to the City of Chicago as compensation for the privilege #1113026 herein granted the sum of three hundred (\$300.00) per annum in advance.

A 25% penalty will be added for payments received after due date.

The permit holder agrees to hold the City of Chicago harmless for any damage, relocation or replacement costs associated with damage, relocation or removal of private property caused by the City performing work in the public way.

Authority herein given and granted for a period of five (5) years from and after 05/13/2014.

Alderman _____

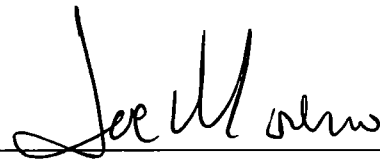

Proco Joe Moreno 1st Ward

1530 W. CHICAGO BUILDING

SIDE WALK

14.83 FT
HEIGHT

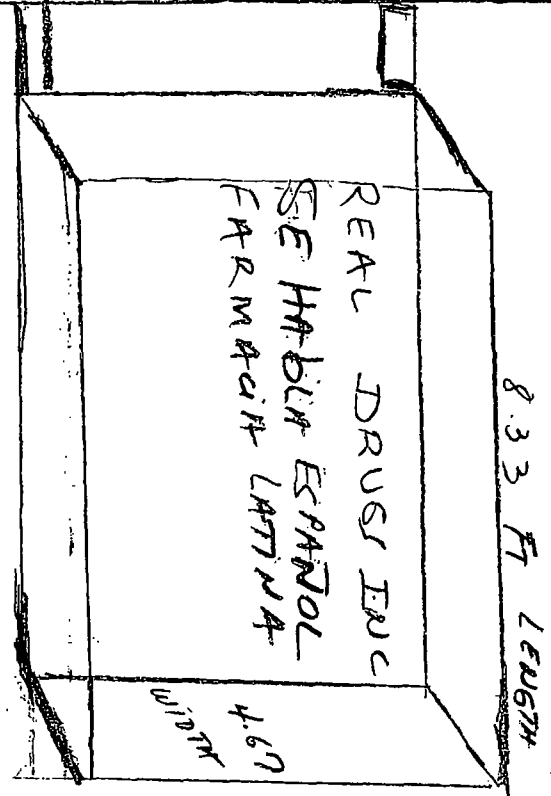



05/28/2014

Alderman **Proco Joe Moreno**
Ward # **01**
City of Chicago
City Hall, Room **300**
121 North LaSalle Street
Chicago, Illinois 60602

Re: An ordinance to use and maintain a portion of the public right-of-way for **one (1) sign(s)** for **REAL DRUGS INC**, adjacent to the premises known as **1530 W. Chicago Ave.**.

Dear Alderman **Proco Joe Moreno**:

The applicant referenced above has requested the use of the public right-of-way for a **sign(s)**. An ordinance has been prepared by the Department of Business Affairs and Consumer Protection – Small Business Center - Public Way Use Unit for presentation to the City Council. Because this request was made for properties located in your ward, as approved by you as per the attached, I respectfully request that you introduce the attached ordinance at the next City Council meeting.

If you have any questions regarding this ordinance, please contact Anthony Bertuca at (312) 744-5506.

Department of Business Affairs and Consumer Protection



City of Chicago



O2014-4321

Office of the City Clerk

Document Tracking Sheet

| | |
|---------------------------------|--|
| Meeting Date: | 5/28/2014 |
| Sponsor(s): | Moreno (1) |
| Type: | Ordinance |
| Title: | Grant(s) of privilege in public way for Reckless Records |
| Committee(s) Assignment: | Committee on Transportation and Public Way |

ORDINANCE
RECKLESS RECORDS
Acct. No. 7149 - 2
Permit No. 1113004

Be It Ordained by the City Council of the City of Chicago:

SECTION 1. Permission and authority are hereby given and granted to RECKLESS RECORDS, upon the terms and subject to the conditions of this ordinance to maintain and use one (1) sign(s) projecting over the public right-of-way attached to its premises known as 1532 N. Milwaukee Ave..

Said sign structure(s) measures as follows; along N. MILWAUKEE:
One (1) at five point five (5.5) feet in length, two point nine two (2.92) feet in height and eleven (11) feet above grade level.

The location of said privilege shall be as shown on prints kept on file with the Department of Business Affairs and Consumer Protection and the Office of the City Clerk.

Said privilege shall be constructed in accordance with plans and specifications approved by the Department of Transportation (Division of Project Development) and Zoning Department - Signs.

This grant of privilege in the public way shall be subject to the provisions of Section 10-28-015 and all other required provisions of the Municipal Code of Chicago.

The grantee shall pay to the City of Chicago as compensation for the privilege #1113004 herein granted the sum of one hundred (\$100.00) per annum in advance.

A 25% penalty will be added for payments received after due date.

The permit holder agrees to hold the City of Chicago harmless for any damage, relocation or replacement costs associated with damage, relocation or removal of private property caused by the City performing work in the public way.

Authority herein given and granted for a period of five (5) years from and after 05/13/2014.

Alderman _____



Proco Joe Moreno 1st Ward

RECKLESS RECORDS
1532 N. MILWAUKEE AVE

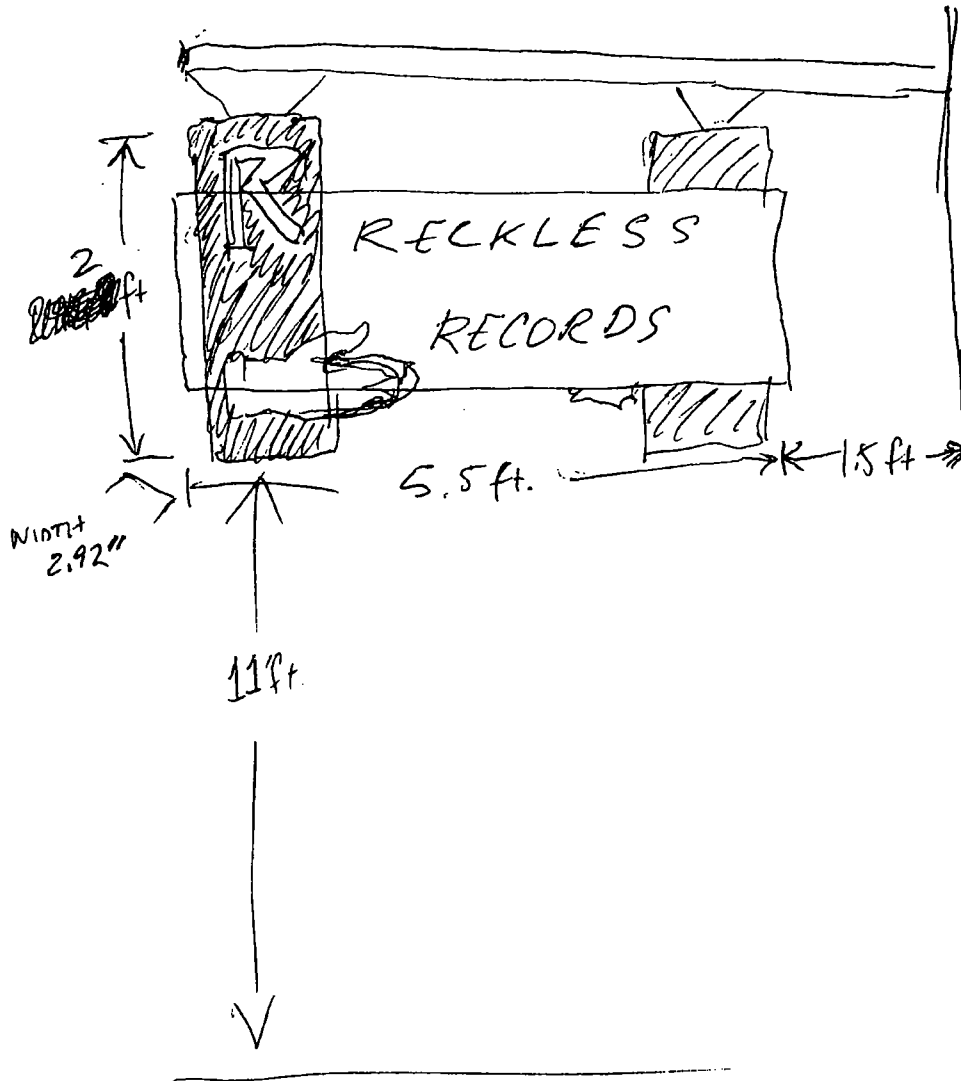



05/28/2014

Alderman **Proco Joe Moreno**
Ward # **01**
City of Chicago
City Hall, Room **300**
121 North LaSalle Street
Chicago, Illinois 60602

Re: An ordinance to use and maintain a portion of the public right-of-way for **one (1) sign(s)** for
RECKLESS RECORDS, adjacent to the premises known as **1532 N. Milwaukee Ave.**.

Dear Alderman **Proco Joe Moreno**:

The applicant referenced above has requested the use of the public right-of-way for a **sign(s)**. An ordinance has been prepared by the Department of Business Affairs and Consumer Protection – Small Business Center - Public Way Use Unit for presentation to the City Council. Because this request was made for properties located in your ward, as approved by you as per the attached, I respectfully request that you introduce the attached ordinance at the next City Council meeting.

If you have any questions regarding this ordinance, please contact Anthony Bertuca at (312) 744-5506.

Department of Business Affairs and Consumer Protection



City of Chicago



O2014-4327

Office of the City Clerk

Document Tracking Sheet

| | |
|---------------------------------|--|
| Meeting Date: | 5/28/2014 |
| Sponsor(s): | Moreno (1) |
| Type: | Ordinance |
| Title: | Grant(s) of privilege in public way for Reckless Records - light fixtures |
| Committee(s) Assignment: | Committee on Transportation and Public Way |

ORDINANCE
RECKLESS RECORDS
Acct. No. 7149 - 2
Permit No. 1113005

Be It Ordained by the City Council of the City of Chicago:

SECTION 1. Permission and authority are hereby given and granted to RECKLESS RECORDS, upon the terms and subject to the conditions of this ordinance to maintain and use, as now constructed, two (2) Light Fixture(s) projecting over the public right-of-way adjacent to its premises known as 1532 N. Milwaukee Ave..

Said Light Fixture(s) at N. MILWAUKEE measure(s):

Two (2) at point three three (.33) feet in length, point three three (.33) feet in width and eleven (11) feet above grade level.

The location of said privilege shall be as shown on prints kept on file with the Department of Business Affairs and Consumer Protection and the Office of the City Clerk.

Said privilege shall be constructed in accordance with plans and specifications approved by the Department of Transportation (Division of Project Development).

This grant of privilege in the public way shall be subject to the provisions of Section 10-28-015 and all other required provisions of the Municipal Code of Chicago.

The grantee shall pay to the City of Chicago as compensation for the privilege #1113005 herein granted the sum of eighty (\$80.00) per annum in advance.

A 25% penalty will be added for payments received after due date.

The permit holder agrees to hold the City of Chicago harmless for any damage, relocation or replacement costs associated with damage, relocation or removal of private property caused by the City performing work in the public way.

Authority herein given and granted for a period of five (5) years from and after 06/03/2014.

Alderman _____ 

Proco Joe Moreno 1st Ward

RECKLESS RECORDS
1532 N. MILWAUKEE AVE

7149 SITE 2

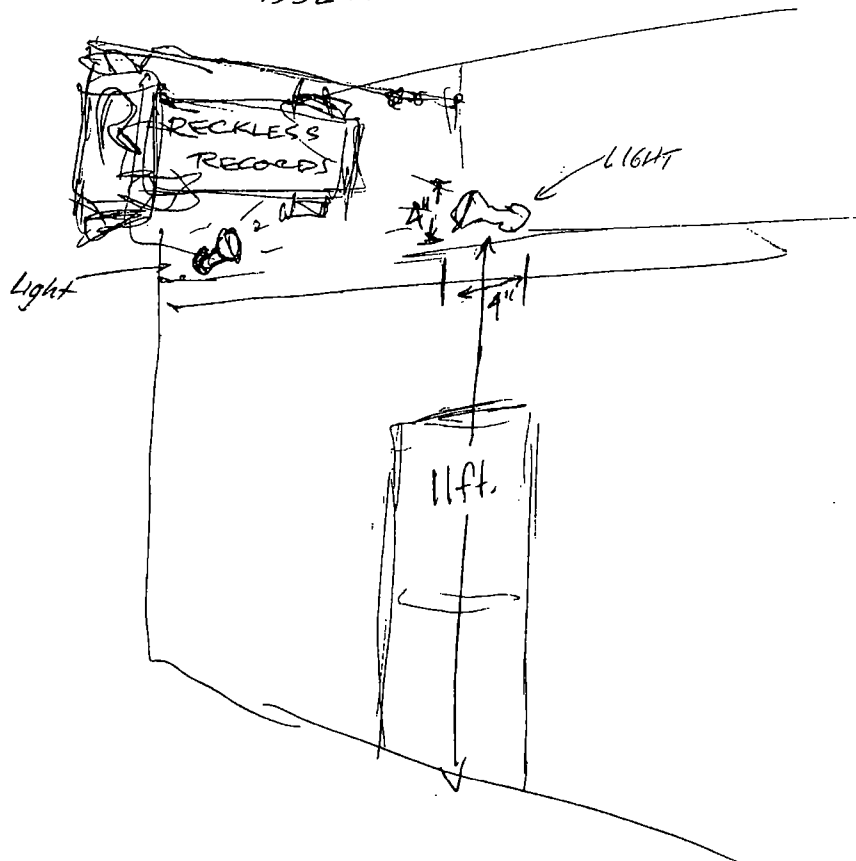



05/28/2014

Alderman **Proco Joe Moreno**
Ward # **01**
City of Chicago
City Hall, Room **300**
121 North LaSalle Street
Chicago, Illinois 60602

Re: An ordinance to use and maintain a portion of the public right-of-way for **two (2) light fixture(s)** for **RECKLESS RECORDS**, adjacent to the premises known as **1532 N. Milwaukee Ave.**.

Dear Alderman **Proco Joe Moreno**:

The applicant referenced above has requested the use of the public right-of-way for a **light fixture(s)**. An ordinance has been prepared by the Department of Business Affairs and Consumer Protection – Small Business Center - Public Way Use Unit for presentation to the City Council. Because this request was made for properties located in your ward, as approved by you as per the attached, I respectfully request that you introduce the attached ordinance at the next City Council meeting.

If you have any questions regarding this ordinance, please contact Anthony Bertuca at (312) 744-5506.

Department of Business Affairs and Consumer Protection



City of Chicago



O2014-4330

Office of the City Clerk

Document Tracking Sheet

| | |
|---------------------------------|---|
| Meeting Date: | 5/28/2014 |
| Sponsor(s): | Moreno (1) |
| Type: | Ordinance |
| Title: | Grant(s) of privilege in public way for Roscoe Village Chamber of Commerce |
| Committee(s) Assignment: | Committee on Transportation and Public Way |

ORDINANCE

Roscoe Village Chamber of Commerce

Acct. No. 389975 - 9

Permit No. 1112800

Be It Ordained by the City Council of the City of Chicago:

SECTION 1. Permission and authority are hereby given and granted to Roscoe Village Chamber of Commerce, upon the terms and subject to the conditions of this ordinance to construct, install, maintain and use one (1) Planter(s) on the public right-of-way for beautification purposes adjacent to its premises known as 2332 W. Belmont Ave..

Said Planter(s) at Belmont measure(s):

One (1) at six point zero eight (6.08) feet in length, and one (1) foot in width for a total of six point zero eight (6.08) square feet.

Grantee must allow the required clear and unobstructed space for pedestrian passage at all times per rules and regulations approved by the Department of Transportation.

The location of said privilege shall be as shown on prints kept on file with the Department of Business Affairs and Consumer Protection and the Office of the City Clerk.

Said privilege shall be constructed in accordance with plans and specifications approved by the Department of Planning and Development and Department of Transportation (Division of Project Development).

This grant of privilege in the public way shall be subject to the provisions of Section 10-28-015 and all other required provisions of the Municipal Code of Chicago.

The grantee shall pay to the City of Chicago as compensation for the privilege #1112800 herein granted the sum of zero (\$0.00) per annum in advance.

A 25% penalty will be added for payments received after due date.

The permit holder agrees to hold the City of Chicago harmless for any damage, relocation or replacement costs associated with damage, relocation or removal of private property caused by the City performing work in the public way.

Authority herein given and granted for a period of five (5) years from and after Date of Passage.

Alderman _____ 

Proco Joe Moreno 1st Ward

ROSCOE VILLAGE CHAMBER OF COMMERCE

ADDRESS: 2332 W BELMONT

LANDSCAPING PROGRAM 2014

(NOT TO SCALE)

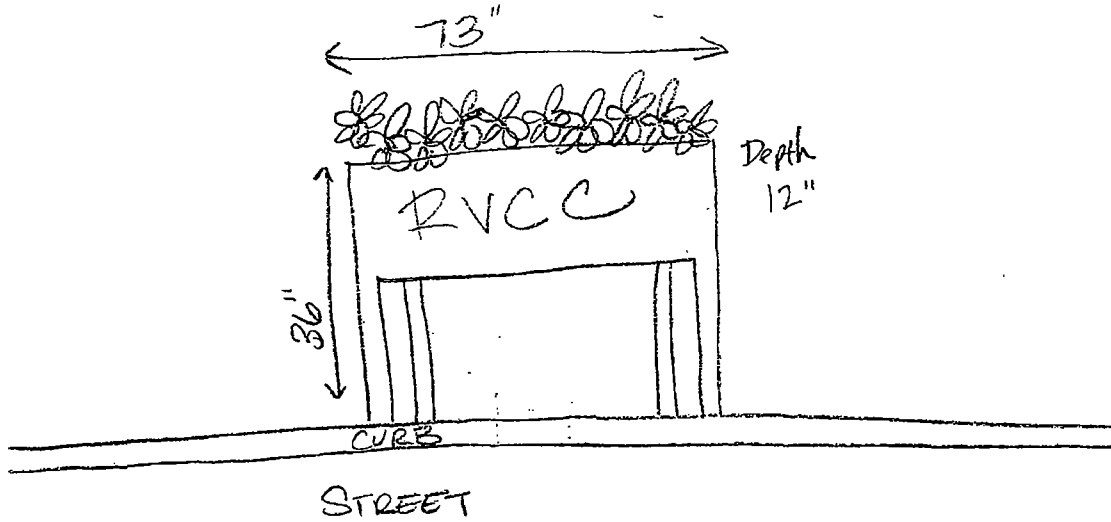
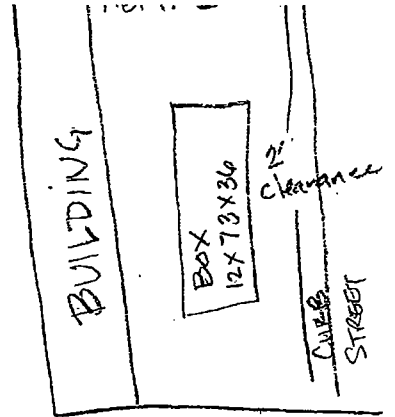



Department of Business Affairs and Consumer Protection
Small Business Center - Public Way Use Unit
City Hall - 121 N. LaSalle Street, Room 800 • Chicago, IL 60602
(312)-74-GOBIZ (312-744-6249) • (312) 744-1944 (TTY)
<http://www.cityofchicago.org/bacp>

05/28/2014

Alderman **Proco Joe Moreno**
Ward # **01**
City of Chicago
City Hall, Room **300**
121 North LaSalle Street
Chicago, Illinois 60602

Re: An ordinance to use and maintain a portion of the public right-of-way for **one (1) planter(s)** for **Roscoe Village Chamber of Commerce**, adjacent to the premises known as **2332 W. Belmont Ave.**.

Dear Alderman **Proco Joe Moreno**:

The applicant referenced above has requested the use of the public right-of-way for a **planter(s)**. An ordinance has been prepared by the Department of Business Affairs and Consumer Protection – Small Business Center - Public Way Use Unit for presentation to the City Council. Because this request was made for properties located in your ward, as approved by you as per the attached, I respectfully request that you introduce the attached ordinance at the next City Council meeting.

If you have any questions regarding this ordinance, please contact Anthony Bertuca at (312) 744-5506.

Department of Business Affairs and Consumer Protection



City of Chicago



O2014-4354

Office of the City Clerk

Document Tracking Sheet

| | |
|---------------------------------|--|
| Meeting Date: | 5/28/2014 |
| Sponsor(s): | Fioretti (2) |
| Type: | Ordinance |
| Title: | Grant(s) of privilege in public way for Argo Tea |
| Committee(s) Assignment: | Committee on Transportation and Public Way |

ORDINANCE
ARGO TEA
Acct. No. 342353 - 1
Permit No. 1113155

Be It Ordained by the City Council of the City of Chicago:

SECTION 1. Permission and authority are hereby given and granted to ARGO TEA, upon the terms and subject to the conditions of this ordinance to maintain and use two (2) sign(s) projecting over the public right-of-way attached to its premises known as 1 S. Franklin St..

Said sign structure(s) measures as follows; along S. FRANKLIN ST.:

One (1) at nineteen point eight three (19.83) feet in length, one point seven nine (1.79) feet in height and ten point zero eight (10.08) feet above grade level.

Said sign structure(s) measures as follows; along W. MADISON ST.:

One (1) at nineteen point eight three (19.83) feet in length, one point seven nine (1.79) feet in height and ten point zero eight (10.08) feet above grade level.

The location of said privilege shall be as shown on prints kept on file with the Department of Business Affairs and Consumer Protection and the Office of the City Clerk.

Said privilege shall be constructed in accordance with plans and specifications approved by the Department of Transportation (Division of Project Development) and Zoning Department - Signs.

This grant of privilege in the public way shall be subject to the provisions of Section 10-28-015 and all other required provisions of the Municipal Code of Chicago.

The grantee shall pay to the City of Chicago as compensation for the privilege #1113155 herein granted the sum of six hundred (\$600.00) per annum in advance.

A 25% penalty will be added for payments received after due date.

The permit holder agrees to hold the City of Chicago harmless for any damage, relocation or replacement costs associated with damage, relocation or removal of private property caused by the City performing work in the public way.

Authority herein given and granted for a period of five (5) years from and after 05/13/2014.

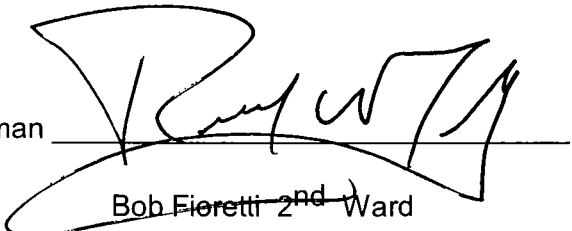
Alderman 
Bob Fioretti 2nd Ward

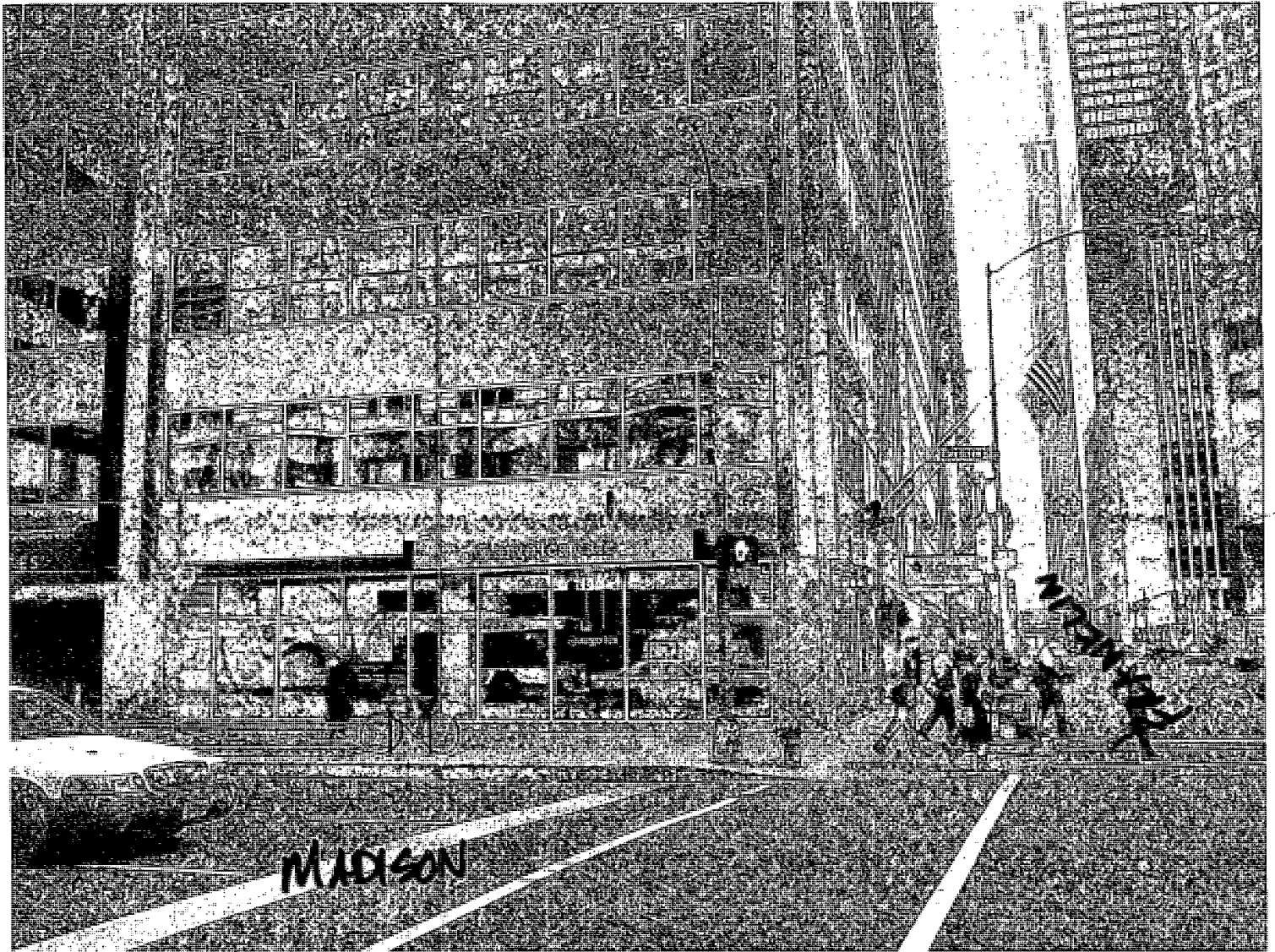



05/28/2014

Alderman **Bob Fioretti**
Ward # **02**
City of Chicago
City Hall, Room **300**
121 North LaSalle Street
Chicago, Illinois 60602

Re: An ordinance to use and maintain a portion of the public right-of-way for **two (2) sign(s)** for **ARGO TEA**, adjacent to the premises known as **1 S. Franklin St.**

Dear Alderman **Bob Fioretti**:

The applicant referenced above has requested the use of the public right-of-way for a **sign(s)**. An ordinance has been prepared by the Department of Business Affairs and Consumer Protection – Small Business Center - Public Way Use Unit for presentation to the City Council. Because this request was made for properties located in your ward, as approved by you as per the attached, I respectfully request that you introduce the attached ordinance at the next City Council meeting.

If you have any questions regarding this ordinance, please contact Anthony Bertuca at (312) 744-5506.

Department of Business Affairs and Consumer Protection



City of Chicago



O2014-4356

Office of the City Clerk

Document Tracking Sheet

| | |
|---------------------------------|---|
| Meeting Date: | 5/28/2014 |
| Sponsor(s): | Fioretti (2) |
| Type: | Ordinance |
| Title: | Grant(s) of privilege in public way for Ashland & Van Buren |
| Committee(s) Assignment: | Committee on Transportation and Public Way |

ORDINANCE
ASHLAND & VAN BUREN
Acct. No. 382032 - 1
Permit No. 1107955

Be It Ordained by the City Council of the City of Chicago:

SECTION 1. Permission and authority are hereby given and granted to ASHLAND & VAN BUREN, upon the terms and subject to the conditions of this ordinance to maintain and use three (3) sign(s) projecting over the public right-of-way attached to its premises known as 1600 W. Van Buren St..

Said sign structure(s) measures as follows; along West Van Buren Street:

One (1) at seven (7) feet in length, seven (7) feet in height and seventeen point two five (17.25) feet above grade level.

One (1) at seven point eight three (7.83) feet in length, six point five (6.5) feet in height and nine point two five (9.25) feet above grade level.

One (1) at six point seven five (6.75) feet in length, one point three three (1.33) feet in height and seventeen point zero eight (17.08) feet above grade level.

The location of said privilege shall be as shown on prints kept on file with the Department of Business Affairs and Consumer Protection and the Office of the City Clerk.

Said privilege shall be constructed in accordance with plans and specifications approved by the Department of Transportation (Division of Project Development) and Zoning Department - Signs.

This grant of privilege in the public way shall be subject to the provisions of Section 10-28-015 and all other required provisions of the Municipal Code of Chicago.

The grantee shall pay to the City of Chicago as compensation for the privilege #1107955 herein granted the sum of seven hundred (\$700.00) per annum in advance.

A 25% penalty will be added for payments received after due date.

The permit holder agrees to hold the City of Chicago harmless for any damage, relocation or replacement costs associated with damage, relocation or removal of private property caused by the City performing work in the public way.

Authority herein given and granted for a period of five (5) years from and after Date of Passage.

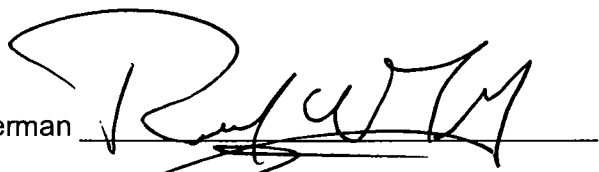
Alderman 
Bob Fioretti 2nd Ward

BP
1600 W Van Buren
Chicago, IL

Pole Sign

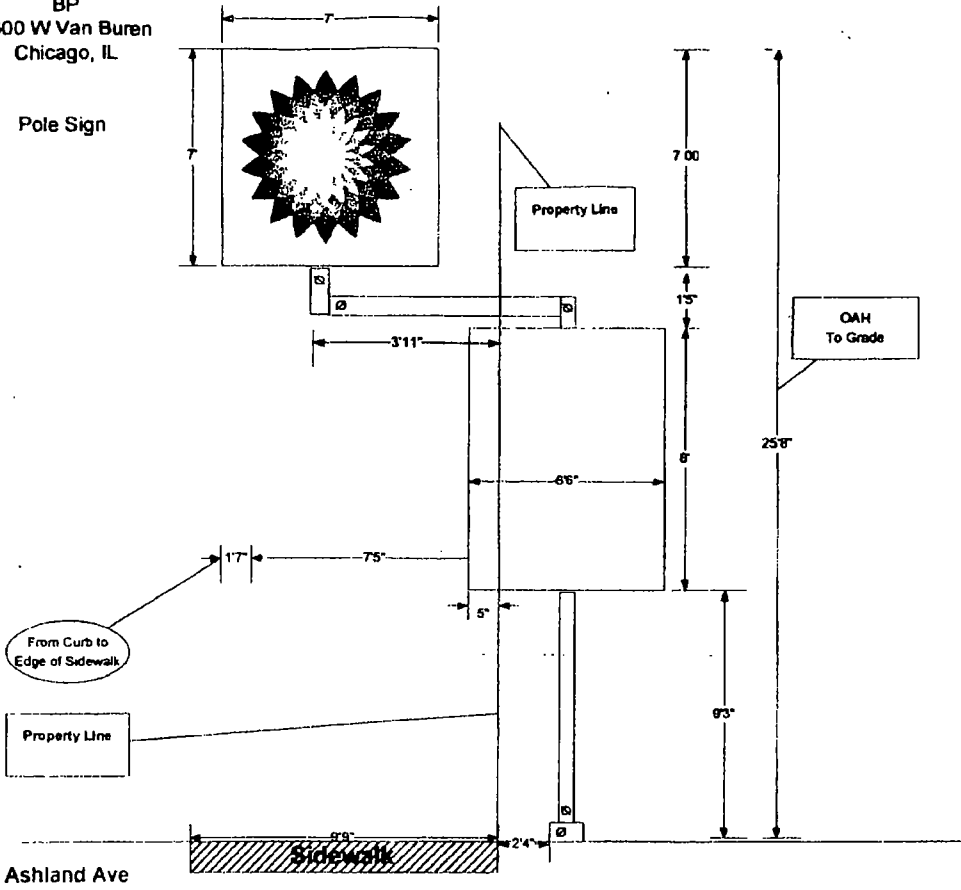

Ashland Ave

Sidewalk

8



05/28/2014

Alderman **Bob Fioretti**
Ward # **02**
City of Chicago
City Hall, Room **300**
121 North LaSalle Street
Chicago, Illinois 60602

Re: An ordinance to use and maintain a portion of the public right-of-way for **three (3) sign(s)** for
ASHLAND & VAN BUREN, adjacent to the premises known as **1600 W. Van Buren St.**

Dear Alderman **Bob Fioretti**:

The applicant referenced above has requested the use of the public right-of-way for a **sign(s)**. An ordinance has been prepared by the Department of Business Affairs and Consumer Protection – Small Business Center - Public Way Use Unit for presentation to the City Council. Because this request was made for properties located in your ward, as approved by you as per the attached, I respectfully request that you introduce the attached ordinance at the next City Council meeting.

If you have any questions regarding this ordinance, please contact Anthony Bertuca at (312) 744-5506.

Department of Business Affairs and Consumer Protection



City of Chicago



O2014-4361

Office of the City Clerk

Document Tracking Sheet

| | |
|---------------------------------|---|
| Meeting Date: | 5/28/2014 |
| Sponsor(s): | Fioretti (2) |
| Type: | Ordinance |
| Title: | Grant(s) of privilege in public way for Brasserie By LM |
| Committee(s) Assignment: | Committee on Transportation and Public Way |

ORDINANCE
BRASSERIE BY LM
Acct. No. 360303 - 1
Permit No. 1105384

Be It Ordained by the City Council of the City of Chicago:

SECTION 1. Permission and authority are hereby given and granted to BRASSERIE BY LM, upon the terms and subject to the conditions of this ordinance to maintain and use, as now constructed, one (1) Wind Screen(s) on the public right-of-way adjacent to its premises known as 800 S. Michigan Ave..

Said Wind Screen(s) at S Michigan Ave measure(s):

One (1) at seven point four two (7.42) feet in length, and five point five (5.5) feet in width for a total of forty point eight one (40.81) square feet.

The location of said privilege shall be as shown on prints kept on file with the Department of Business Affairs and Consumer Protection and the Office of the City Clerk.

Said privilege shall be constructed in accordance with plans and specifications approved by the Department of Transportation (Division of Project Development).

This grant of privilege in the public way shall be subject to the provisions of Section 10-28-015 and all other required provisions of the Municipal Code of Chicago.

The grantee shall pay to the City of Chicago as compensation for the privilege #1105384 herein granted the sum of four hundred (\$400.00) per annum in advance.

A 25% penalty will be added for payments received after due date.

The permit holder agrees to hold the City of Chicago harmless for any damage, relocation or replacement costs associated with damage, relocation or removal of private property caused by the City performing work in the public way.

Authority herein given and granted for a period of five (5) years from and after Date of Passage.

Alderman



Bob Fioretti 2nd Ward

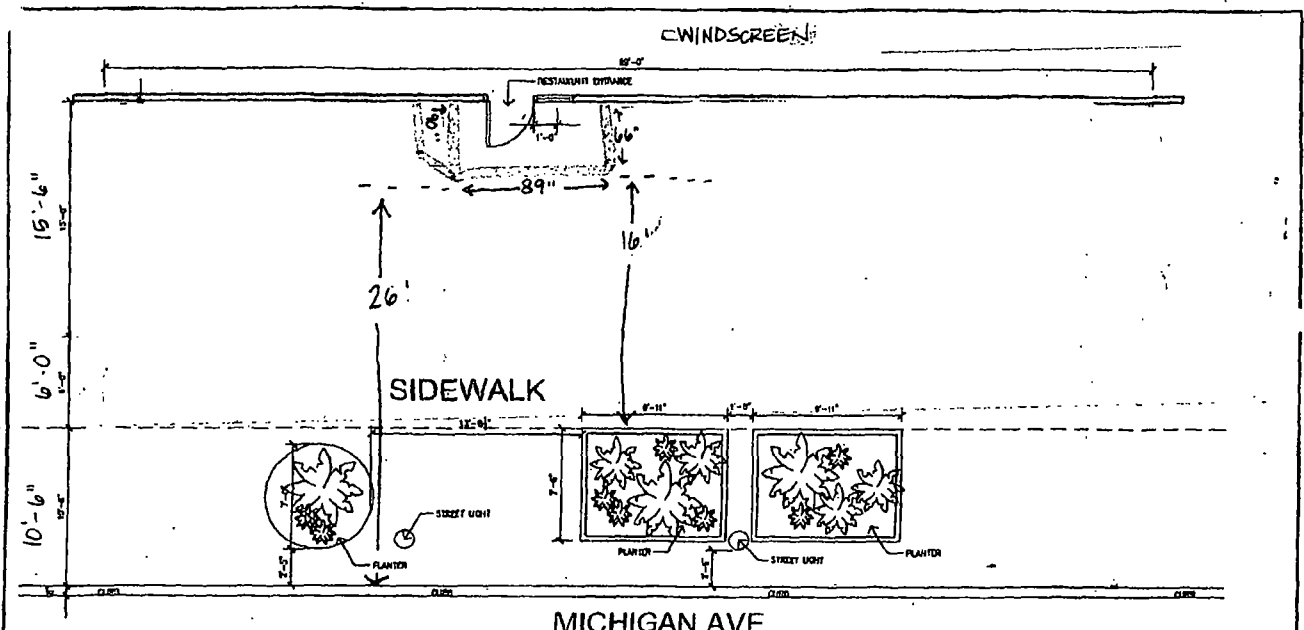

MICHIGAN AVE

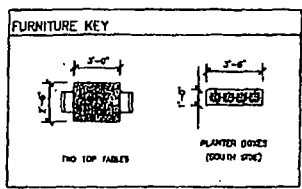

NAME: TRIBUTE RESTAURANT

DATE: 07.13.2011

SCALE: NO SCALE

TELEPHONE: 312.957.000

TRIBUTE RESTAURANT

800 SOUTH MICHIGAN AVE
CHICAGO, IL 60605





05/28/2014

Alderman **Bob Fioretti**
Ward # **02**
City of Chicago
City Hall, Room **300**
121 North LaSalle Street
Chicago, Illinois 60602

Re: An ordinance to use and maintain a portion of the public right-of-way for **one (1) wind screen(s)** for **BRASSERIE BY LM**, adjacent to the premises known as **800 S. Michigan Ave.**.

Dear Alderman **Bob Fioretti**:

The applicant referenced above has requested the use of the public right-of-way for a **wind screen(s)**. An ordinance has been prepared by the Department of Business Affairs and Consumer Protection – Small Business Center - Public Way Use Unit for presentation to the City Council. Because this request was made for properties located in your ward, as approved by you as per the attached, I respectfully request that you introduce the attached ordinance at the next City Council meeting.

If you have any questions regarding this ordinance, please contact Anthony Bertuca at (312) 744-5506.

Department of Business Affairs and Consumer Protection



City of Chicago



O2014-4364

Office of the City Clerk

Document Tracking Sheet

| | |
|---------------------------------|---|
| Meeting Date: | 5/28/2014 |
| Sponsor(s): | Fioretti (2) |
| Type: | Ordinance |
| Title: | Grant(s) of privilege in public way for Daily Parking, Inc. |
| Committee(s) Assignment: | Committee on Transportation and Public Way |

ORDINANCE
DAILY PARKING INC
Acct. No. 4737 - 1
Permit No. 1112880

Be It Ordained by the City Council of the City of Chicago:

SECTION 1. Permission and authority are hereby given and granted to DAILY PARKING INC, upon the terms and subject to the conditions of this ordinance to maintain and use two (2) sign(s) projecting over the public right-of-way attached to its premises known as 410 S. Wabash Ave..

Said sign structure(s) measures as follows; along S Wabash Ave:

Two (2) at eight (8) feet in length, three (3) feet in height and eleven (11) feet above grade level.

The location of said privilege shall be as shown on prints kept on file with the Department of Business Affairs and Consumer Protection and the Office of the City Clerk.

Said privilege shall be constructed in accordance with plans and specifications approved by the Department of Transportation (Division of Project Development) and Zoning Department - Signs.

This grant of privilege in the public way shall be subject to the provisions of Section 10-28-015 and all other required provisions of the Municipal Code of Chicago.

The grantee shall pay to the City of Chicago as compensation for the privilege #1112880 herein granted the sum of one hundred seventy-five (\$175.00) per annum in advance.

A 25% penalty will be added for payments received after due date.

The permit holder agrees to hold the City of Chicago harmless for any damage, relocation or replacement costs associated with damage, relocation or removal of private property caused by the City performing work in the public way.

Authority herein given and granted for a period of five (5) years from and after 11/19/2013.

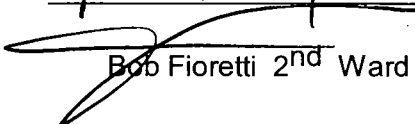
Alderman 

Bob Fioretti 2nd Ward



APPLICATION TO USE THE PUBLIC RIGHT OF WAY

EXAMPLE OF SIGN DRAWING

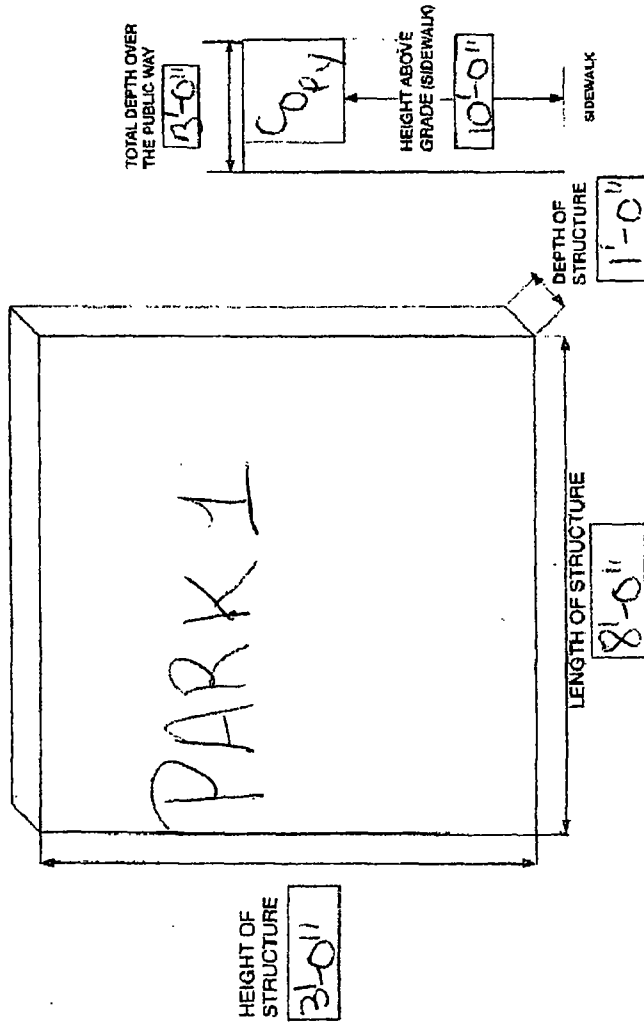
SIGN DRAWING
 PROPERTY LOCATION: H10 S. WABASH AVE
 ORGANIZATION(S) NAME: DAILY PARKING INC





05/28/2014

Alderman **Bob Fioretti**
Ward # **02**
City of Chicago
City Hall, Room **300**
121 North LaSalle Street
Chicago, Illinois 60602

Re: An ordinance to use and maintain a portion of the public right-of-way for **two (2) sign(s)** for **DAILY PARKING INC**, adjacent to the premises known as **410 S. Wabash Ave.**.

Dear Alderman **Bob Fioretti**:

The applicant referenced above has requested the use of the public right-of-way for a **sign(s)**. An ordinance has been prepared by the Department of Business Affairs and Consumer Protection – Small Business Center - Public Way Use Unit for presentation to the City Council. Because this request was made for properties located in your ward, as approved by you as per the attached, I respectfully request that you introduce the attached ordinance at the next City Council meeting.

If you have any questions regarding this ordinance, please contact Anthony Bertuca at (312) 744-5506.

Department of Business Affairs and Consumer Protection



City of Chicago



O2014-4365

Office of the City Clerk

Document Tracking Sheet

| | |
|---------------------------------|--|
| Meeting Date: | 5/28/2014 |
| Sponsor(s): | Fioretti (2) |
| Type: | Ordinance |
| Title: | Grant(s) of privilege in public way for Jaks Tap |
| Committee(s) Assignment: | Committee on Transportation and Public Way |

ORDINANCE
Jaks Tap
Acct. No. 17185 - 1
Permit No. 1112798

Be It Ordained by the City Council of the City of Chicago:

SECTION 1. Permission and authority are hereby given and granted to Jaks Tap, upon the terms and subject to the conditions of this ordinance to maintain and use one (1) sign(s) projecting over the public right-of-way attached to its premises known as 901 W. Jackson Blvd..

Said sign structure(s) measures as follows; along W. Jackson Avenue:
One (1) at one (1) foot in length, eight (8) feet in height and eighteen (18) feet above grade level.

The location of said privilege shall be as shown on prints kept on file with the Department of Business Affairs and Consumer Protection and the Office of the City Clerk.

Said privilege shall be constructed in accordance with plans and specifications approved by the Department of Transportation (Division of Project Development) and Zoning Department - Signs.

This grant of privilege in the public way shall be subject to the provisions of Section 10-28-015 and all other required provisions of the Municipal Code of Chicago.

The grantee shall pay to the City of Chicago as compensation for the privilege #1112798 herein granted the sum of one hundred (\$100.00) per annum in advance.

A 25% penalty will be added for payments received after due date.

The permit holder agrees to hold the City of Chicago harmless for any damage, relocation or replacement costs associated with damage, relocation or removal of private property caused by the City performing work in the public way.

Authority herein given and granted for a period of five (5) years from and after 07/30/2013.

Alderman. 
Bob Fioretti 2nd Ward





05/28/2014

Alderman **Bob Fioretti**
Ward # **02**
City of Chicago
City Hall, Room **300**
121 North LaSalle Street
Chicago, Illinois 60602

Re: An ordinance to use and maintain a portion of the public right-of-way for **one (1) sign(s)** for **Jaks Tap**, adjacent to the premises known as **901 W. Jackson Blvd.**.

Dear Alderman **Bob Fioretti**:

The applicant referenced above has requested the use of the public right-of-way for a **sign(s)**. An ordinance has been prepared by the Department of Business Affairs and Consumer Protection – Small Business Center - Public Way Use Unit for presentation to the City Council. Because this request was made for properties located in your ward, as approved by you as per the attached, I respectfully request that you introduce the attached ordinance at the next City Council meeting.

If you have any questions regarding this ordinance, please contact Anthony Bertuca at (312) 744-5506.

Department of Business Affairs and Consumer Protection



City of Chicago



O2014-4373

Office of the City Clerk

Document Tracking Sheet

| | |
|---------------------------------|--|
| Meeting Date: | 5/28/2014 |
| Sponsor(s): | Fioretti (2) |
| Type: | Ordinance |
| Title: | Grant(s) of privilege in public way for Paramount Lofts Condo Assn. - balconies |
| Committee(s) Assignment: | Committee on Transportation and Public Way |

ORDINANCE
PARAMOUNT LOFTS CONDO ASSN.
Acct. No. 325741 - 1
Permit No. 1112944

Be It Ordained by the City Council of the City of Chicago:

SECTION 1. Permission and authority are hereby given and granted to PARAMOUNT LOFTS CONDO ASSN., upon the terms and subject to the conditions of this ordinance to maintain and use, as now constructed, one hundred forty (140) Balcony(s) projecting over the public right-of-way adjacent to its premises known as 1645 W. Ogden Ave..

Said Balcony(s) at W. Ogden Avenue measure(s):

One hundred forty (140) at twelve point four (12.4) feet in length, and five (5) feet in width for a total of eight thousand six hundred eighty (8680) square feet.

The location of said privilege shall be as shown on prints kept on file with the Department of Business Affairs and Consumer Protection and the Office of the City Clerk.

Said privilege shall be constructed in accordance with plans and specifications approved by the Department of Planning and Development and Department of Transportation (Division of Project Development).

This grant of privilege in the public way shall be subject to the provisions of Section 10-28-015 and all other required provisions of the Municipal Code of Chicago.

The grantee shall pay to the City of Chicago as compensation for the privilege #1112944 herein granted the sum of ten thousand five hundred (\$10,500.00) per annum in advance.

A 25% penalty will be added for payments received after due date.

The permit holder agrees to hold the City of Chicago harmless for any damage, relocation or replacement costs associated with damage, relocation or removal of private property caused by the City performing work in the public way.

Authority herein given and granted for a period of five (5) years from and after 01/13/2014.

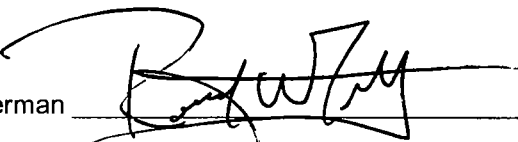
Alderman 
Bob Fioretti 2nd Ward

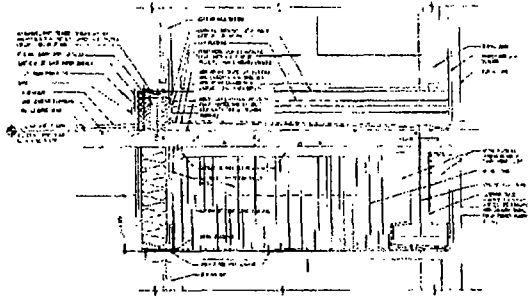

8 COURTYARD BALCONY SECTION

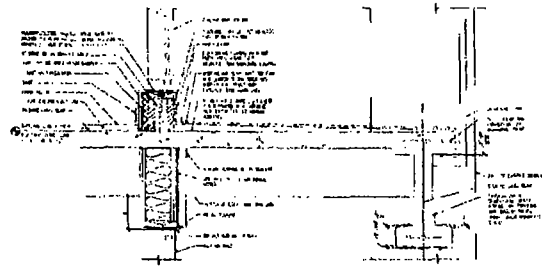

7 COURTYARD BALCONY SECTION

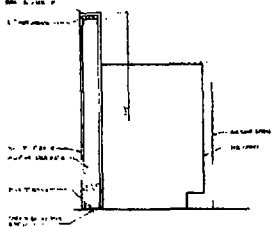

6 DETAIL @KITCHEN ISLAND

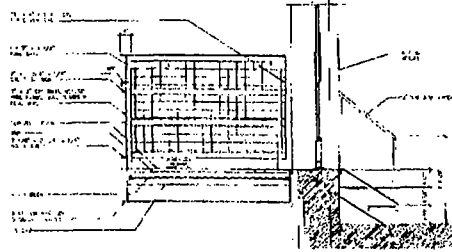

4 SECTION @SECOND FLOOR BALCONY

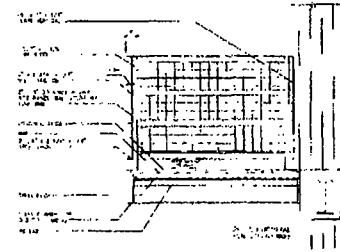

2 TYPICAL BALCONY SECTION



5 DETAIL @DOUBLE MULLION

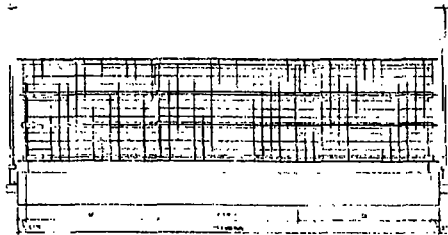

3 TYP. BALCONY FRONT ELEVATION

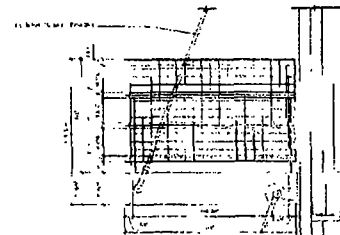

1 TYP. BALCONY SIDE ELEVATION

Paramount
Lofts
1615 N. CORKER AVE.
CHICAGO, ILLINOIS

DATE: 03/12/2014
TIME: 05:34
PROJECT: 41
DRAWING: 312260671

DETAIL

A4.00



05/28/2014

Alderman **Bob Fioretti**
Ward # **02**
City of Chicago
City Hall, Room **300**
121 North LaSalle Street
Chicago, Illinois 60602

Re: An ordinance to use and maintain a portion of the public right-of-way for **one hundred forty (140) balcony(ies)** for **PARAMOUNT LOFTS CONDO ASSN.**, adjacent to the premises known as **1645 W. Ogden Ave.**.

Dear Alderman **Bob Fioretti**:

The applicant referenced above has requested the use of the public right-of-way for a **balcony(ies)**. An ordinance has been prepared by the Department of Business Affairs and Consumer Protection – Small Business Center - Public Way Use Unit for presentation to the City Council. Because this request was made for properties located in your ward, as approved by you as per the attached, I respectfully request that you introduce the attached ordinance at the next City Council meeting.

If you have any questions regarding this ordinance, please contact Anthony Bertuca at (312) 744-5506.

Department of Business Affairs and Consumer Protection



City of Chicago



O2014-4390

Office of the City Clerk

Document Tracking Sheet

| | |
|---------------------------------|---|
| Meeting Date: | 5/28/2014 |
| Sponsor(s): | Fioretti (2) |
| Type: | Ordinance |
| Title: | Grant(s) of privilege in public way for Paramount Lofts Condo Assn. - grease separator |
| Committee(s) Assignment: | Committee on Transportation and Public Way |

ORDINANCE
PARAMOUNT LOFTS CONDO ASSN.
Acct. No. 325741 - 1
Permit No. 1112945

Be It Ordained by the City Council of the City of Chicago:

SECTION 1. Permission and authority are hereby given and granted to PARAMOUNT LOFTS CONDO ASSN., upon the terms and subject to the conditions of this ordinance to maintain and use, as now constructed, one (1) Grease Separator(s) under the public right-of-way adjacent to its premises known as 1645 W. Ogden Ave..

Said Grease Separator(s) at W. OGDEN AVE. measure(s):
One (1) at ten (10) feet in length, and five (5) feet in width for a total of fifty (50) square feet.

The location of said privilege shall be as shown on prints kept on file with the Department of Business Affairs and Consumer Protection and the Office of the City Clerk.

Said privilege shall be constructed in accordance with plans and specifications approved by the Department of Transportation (Division of Project Development), Department of Transportation (Office of Underground Coordination), and Department of Water Management.

This grant of privilege in the public way shall be subject to the provisions of Section 10-28-015 and all other required provisions of the Municipal Code of Chicago.

The grantee shall pay to the City of Chicago as compensation for the privilege #1112945 herein granted the sum of four hundred (\$400.00) per annum in advance.

A 25% penalty will be added for payments received after due date.

The permit holder agrees to hold the City of Chicago harmless for any damage, relocation or replacement costs associated with damage, relocation or removal of private property caused by the City performing work in the public way.

Authority herein given and granted for a period of five (5) years from and after 03/12/2013.

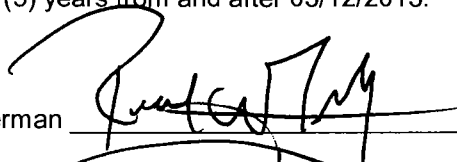
Alderman 
Bob Fioretti 2nd Ward

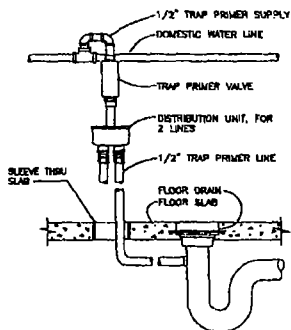

1 TRAP PRIMER DETAIL
NOT TO SCALE

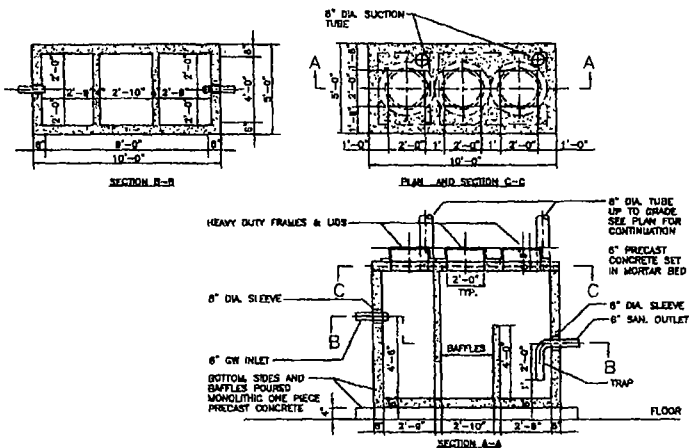

2 STANDARD CITY OF CHICAGO GREASE SEPARATOR DETAIL
NOT TO SCALE

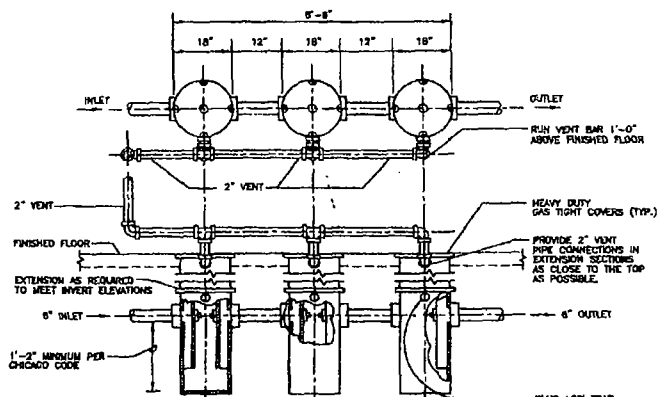

3 STANDARD CITY OF CHICAGO

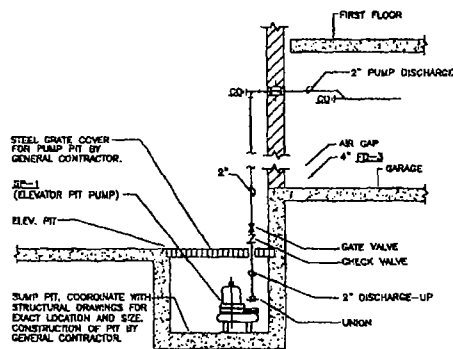

4 ELEVATOR SUMP PIT DETAIL

| TAG-- | LOCATION |
|-------|------------------|
| BP-1 | PUMP ROOM |
| HP-1 | WATER HEATER POC |
| SE-1 | PUMP ROOM |
| SP-1 | ELEVATOR PIT |

| FIXTURE SYMBOL | RIM ELEVATION |
|----------------|---------------|
| SE-1 | +2'-0" |

SE-1 REQUIREMENTS: CONTROL WATER ALARM PANEL, SHALL BE ANTI-FLOTATION FLANGE. A ST BACK-UP SYSTEM, EACH BACK CYCLE BATTERIES EACH, TO PR

METAL PIPE
ESCUTCHEON
FLOOR SLAB.



05/28/2014

Alderman **Bob Fioretti**
Ward # **02**
City of Chicago
City Hall, Room **300**
121 North LaSalle Street
Chicago, Illinois 60602

Re: An ordinance to use and maintain a portion of the public right-of-way for **one (1) grease separator(s)** for **PARAMOUNT LOFTS CONDO ASSN.**, adjacent to the premises known as **1645 W. Ogden Ave.**.

Dear Alderman **Bob Fioretti**:

The applicant referenced above has requested the use of the public right-of-way for a **grease separator(s)**. An ordinance has been prepared by the Department of Business Affairs and Consumer Protection – Small Business Center - Public Way Use Unit for presentation to the City Council. Because this request was made for properties located in your ward, as approved by you as per the attached, I respectfully request that you introduce the attached ordinance at the next City Council meeting.

If you have any questions regarding this ordinance, please contact Anthony Bertuca at (312) 744-5506.

Department of Business Affairs and Consumer Protection



City of Chicago



O2014-4396

Office of the City Clerk

Document Tracking Sheet

| | |
|---------------------------------|---|
| Meeting Date: | 5/28/2014 |
| Sponsor(s): | Fioretti (2) |
| Type: | Ordinance |
| Title: | Grant(s) of privilege in public way for Petco |
| Committee(s) Assignment: | Committee on Transportation and Public Way |

ORDINANCE
Petco
Acct. No. 19916 - 18
Permit No. 1109937

Be It Ordained by the City Council of the City of Chicago:

SECTION 1. Permission and authority are hereby given and granted to Petco, upon the terms and subject to the conditions of this ordinance to maintain and use three (3) sign(s) projecting over the public right-of-way attached to its premises known as 611 W. Roosevelt Rd..

Said sign structure(s) measures as follows; along Roosevelt:

One (1) at twelve point zero eight (12.08) feet in length, two point four six (2.46) feet in height and fourteen (14) feet above grade level.

One (1) at ten (10) feet in length, four (4) feet in height and fourteen (14) feet above grade level.

One (1) at twenty-six point six seven (26.67) feet in length, five point eight seven (5.87) feet in height and fourteen (14) feet above grade level.

The location of said privilege shall be as shown on prints kept on file with the Department of Business Affairs and Consumer Protection and the Office of the City Clerk.

Said privilege shall be constructed in accordance with plans and specifications approved by the Department of Transportation (Division of Project Development) and Zoning Department - Signs.

This grant of privilege in the public way shall be subject to the provisions of Section 10-28-015 and all other required provisions of the Municipal Code of Chicago.

The grantee shall pay to the City of Chicago as compensation for the privilege #1109937 herein granted the sum of nine hundred (\$900.00) per annum in advance.

A 25% penalty will be added for payments received after due date.

The permit holder agrees to hold the City of Chicago harmless for any damage, relocation or replacement costs associated with damage, relocation or removal of private property caused by the City performing work in the public way.

Authority herein given and granted for a period of five (5) years from and after Date of Passage.

Alderman

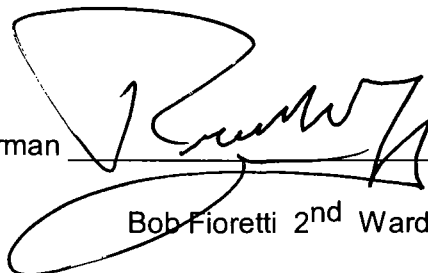

Bob Fioretti 2nd Ward

A

Front Elevation

Maximum signage per code is 300 sq. ft.
Proposed Signage: 210.76 sq. ft.



LED ILLUMINATED

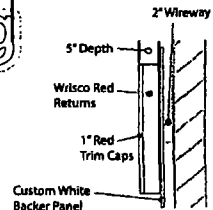
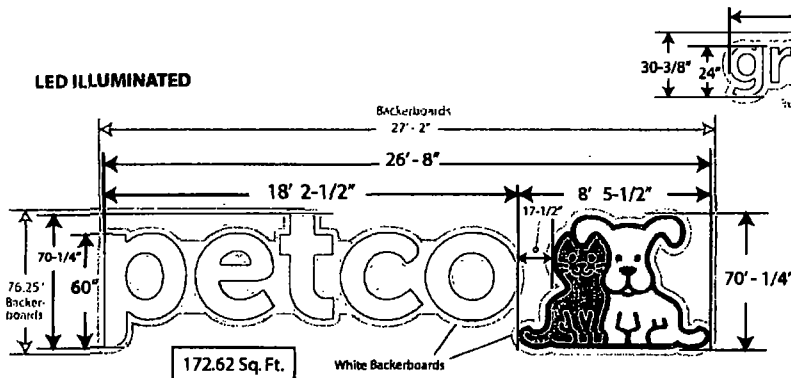

| COLOR REFERENCE | 3M 3630-53 Cardinal Red | 3M3630-57 Blue | 3M7725-22 Black |
|-----------------|-------------------------|----------------|-----------------|
| | | | |



Everbrite, LLC
4949 South 110th Street
P.O. Box 20020
Greenfield, WI 53220-0020
www.everbrite.com

All ideas, plans or arrangements indicated in this drawing are copyrighted and owned by Everbrite and may not be reproduced, used by or disclosed to any person, firm or corporation for any purpose whatsoever, without written permission.

Site: PETCOT371 CHICAGO, IL
Prepared By: Dan Kolmas; 298524-2
Date: 09/12/2013

A



05/28/2014

Alderman **Bob Fioretti**
Ward # **02**
City of Chicago
City Hall, Room **300**
121 North LaSalle Street
Chicago, Illinois 60602

Re: An ordinance to use and maintain a portion of the public right-of-way for **three (3) sign(s)** for **Petco**, adjacent to the premises known as **611 W. Roosevelt Rd.**

Dear Alderman **Bob Fioretti**:

The applicant referenced above has requested the use of the public right-of-way for a **sign(s)**. An ordinance has been prepared by the Department of Business Affairs and Consumer Protection – Small Business Center - Public Way Use Unit for presentation to the City Council. Because this request was made for properties located in your ward, as approved by you as per the attached, I respectfully request that you introduce the attached ordinance at the next City Council meeting.

If you have any questions regarding this ordinance, please contact Anthony Bertuca at (312) 744-5506.

Department of Business Affairs and Consumer Protection



City of Chicago



O2014-4404

Office of the City Clerk

Document Tracking Sheet

| | |
|---------------------------------|---|
| Meeting Date: | 5/28/2014 |
| Sponsor(s): | Fioretti (2) |
| Type: | Ordinance |
| Title: | Grant(s) of privilege in public way for St. Leonard's Ministries |
| Committee(s) Assignment: | Committee on Transportation and Public Way |

ORDINANCE
ST. LEONARD'S MINISTRIES
Acct. No. 275797 - 1
Permit No. 1113076

Be It Ordained by the City Council of the City of Chicago:

SECTION 1. Permission and authority are hereby given and granted to ST. LEONARD'S MINISTRIES, upon the terms and subject to the conditions of this ordinance to maintain and use, as now constructed, one (1) Tree Grates(s) on the public right-of-way adjacent to its premises known as 2120 W. Warren Blvd..

Said Tree Grates(s) at W. WARREN BLVD measure(s):
One (1) at one (1) foot in length, and one (1) foot in width for a total of one (1) square feet.

The location of said privilege shall be as shown on prints kept on file with the Department of Business Affairs and Consumer Protection and the Office of the City Clerk.

Said privilege shall be constructed in accordance with plans and specifications approved by the Department of Planning and Development and Department of Transportation (Division of Project Development).

This grant of privilege in the public way shall be subject to the provisions of Section 10-28-015 and all other required provisions of the Municipal Code of Chicago.

The grantee shall pay to the City of Chicago as compensation for the privilege #1113076 herein granted the sum of zero (\$.00) per annum in advance.

A 25% penalty will be added for payments received after due date.

The permit holder agrees to hold the City of Chicago harmless for any damage, relocation or replacement costs associated with damage, relocation or removal of private property caused by the City performing work in the public way.

Authority herein given and granted for a period of five (5) years from and after 05/26/2014.

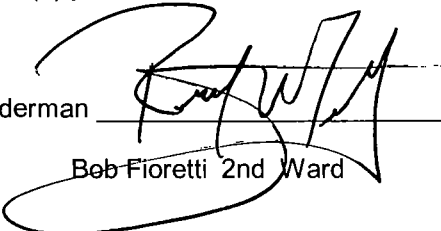
Alderman  _____
Bob Fioretti 2nd Ward

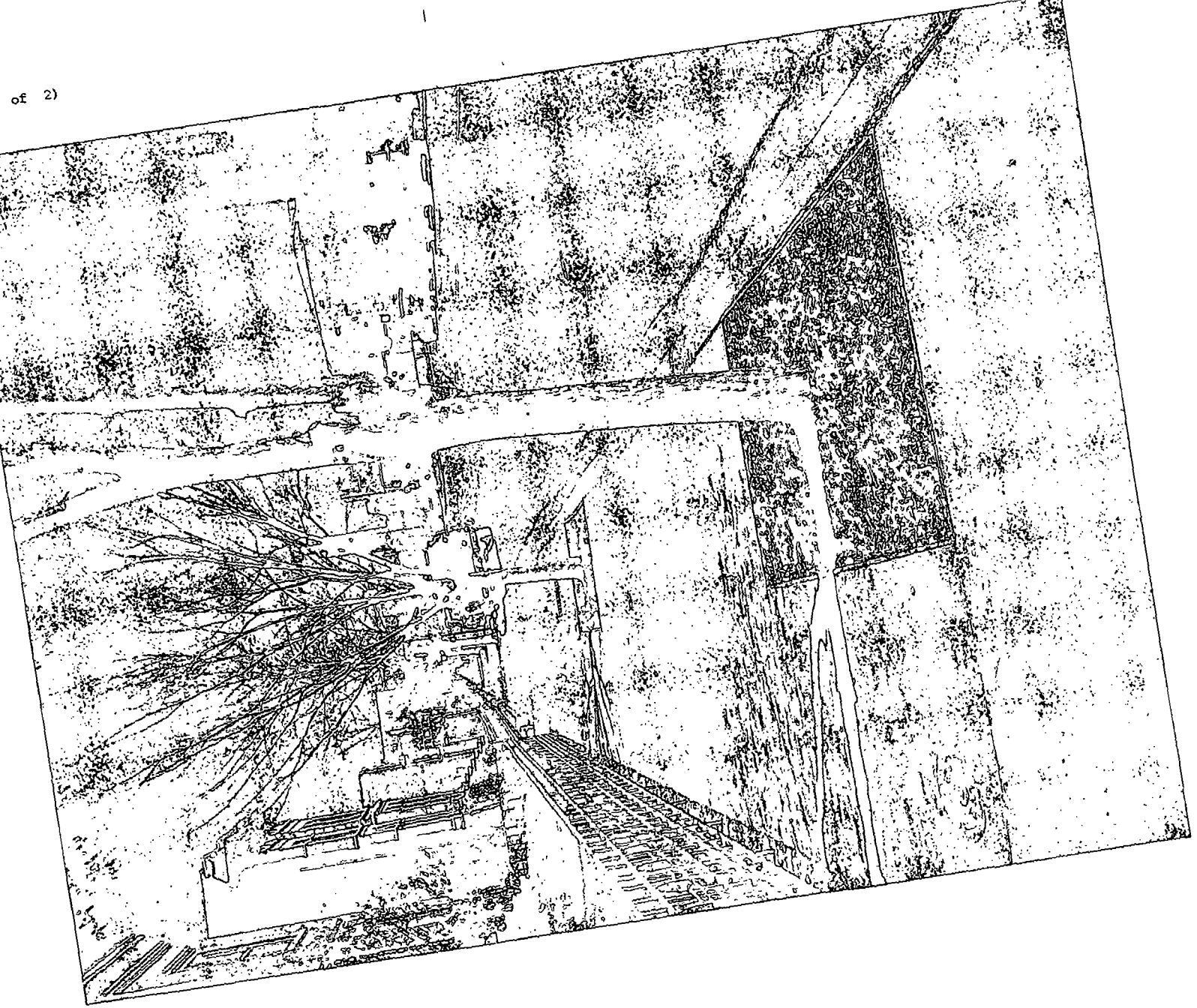



05/28/2014

Alderman **Bob Fioretti**
Ward # **02**
City of Chicago
City Hall, Room **300**
121 North LaSalle Street
Chicago, Illinois 60602

Re: An ordinance to use and maintain a portion of the public right-of-way for **one (1) tree grates(s)** for **ST. LEONARD'S MINISTRIES**, adjacent to the premises known as **2120 W. Warren Blvd.**

Dear Alderman **Bob Fioretti**:

The applicant referenced above has requested the use of the public right-of-way for a **tree grates(s)**. An ordinance has been prepared by the Department of Business Affairs and Consumer Protection – Small Business Center - Public Way Use Unit for presentation to the City Council. Because this request was made for properties located in your ward, as approved by you as per the attached, I respectfully request that you introduce the attached ordinance at the next City Council meeting.

If you have any questions regarding this ordinance, please contact Anthony Bertuca at (312) 744-5506.

Department of Business Affairs and Consumer Protection



City of Chicago



O2014-4424

Office of the City Clerk

Document Tracking Sheet

| | |
|---------------------------------|--|
| Meeting Date: | 5/28/2014 |
| Sponsor(s): | Fioretti (2) |
| Type: | Ordinance |
| Title: | Grant(s) of privilege in public way for 36th and King Drive, Inc. Amoco |
| Committee(s) Assignment: | Committee on Transportation and Public Way |

ORDINANCE
36TH AND KING DRIVE INC AMOCO
Acct. No. 223173 - 1
Permit No. 1113107

Be It Ordained by the City Council of the City of Chicago:

SECTION 1. Permission and authority are hereby given and granted to 36TH AND KING DRIVE INC AMOCO, upon the terms and subject to the conditions of this ordinance to maintain and use two (2) sign(s) projecting over the public right-of-way attached to its premises known as 342 E. 35th St..

Said sign structure(s) measures as follows; along E. 35th St:
One (1) at seven (7) feet in length, seven (7) feet in height and seventeen point five eight (17.58) feet above grade level.

Said sign structure(s) measures as follows; along W. 35th St:
One (1) at six point five (6.5) feet in length, five point five (5.5) feet in height and eight point five (8.5) feet above grade level.

The location of said privilege shall be as shown on prints kept on file with the Department of Business Affairs and Consumer Protection and the Office of the City Clerk.

Said privilege shall be constructed in accordance with plans and specifications approved by the Department of Transportation (Division of Project Development) and Zoning Department - Signs.

This grant of privilege in the public way shall be subject to the provisions of Section 10-28-015 and all other required provisions of the Municipal Code of Chicago.

The grantee shall pay to the City of Chicago as compensation for the privilege #1113107 herein granted the sum of six hundred (\$600.00) per annum in advance.

A 25% penalty will be added for payments received after due date.

The permit holder agrees to hold the City of Chicago harmless for any damage, relocation or replacement costs associated with damage, relocation or removal of private property caused by the City performing work in the public way.

Authority herein given and granted for a period of five (5) years from and after 05/13/2014.

Alderman



Bob Fioretti 2nd Ward

BP AMOCO
342 E. 35th St
CHICAGO, IL

SIGN BASE
CLOSEUP
MLK DR.

OVERHANG
MEASUREMENTS
ARE APPROX.

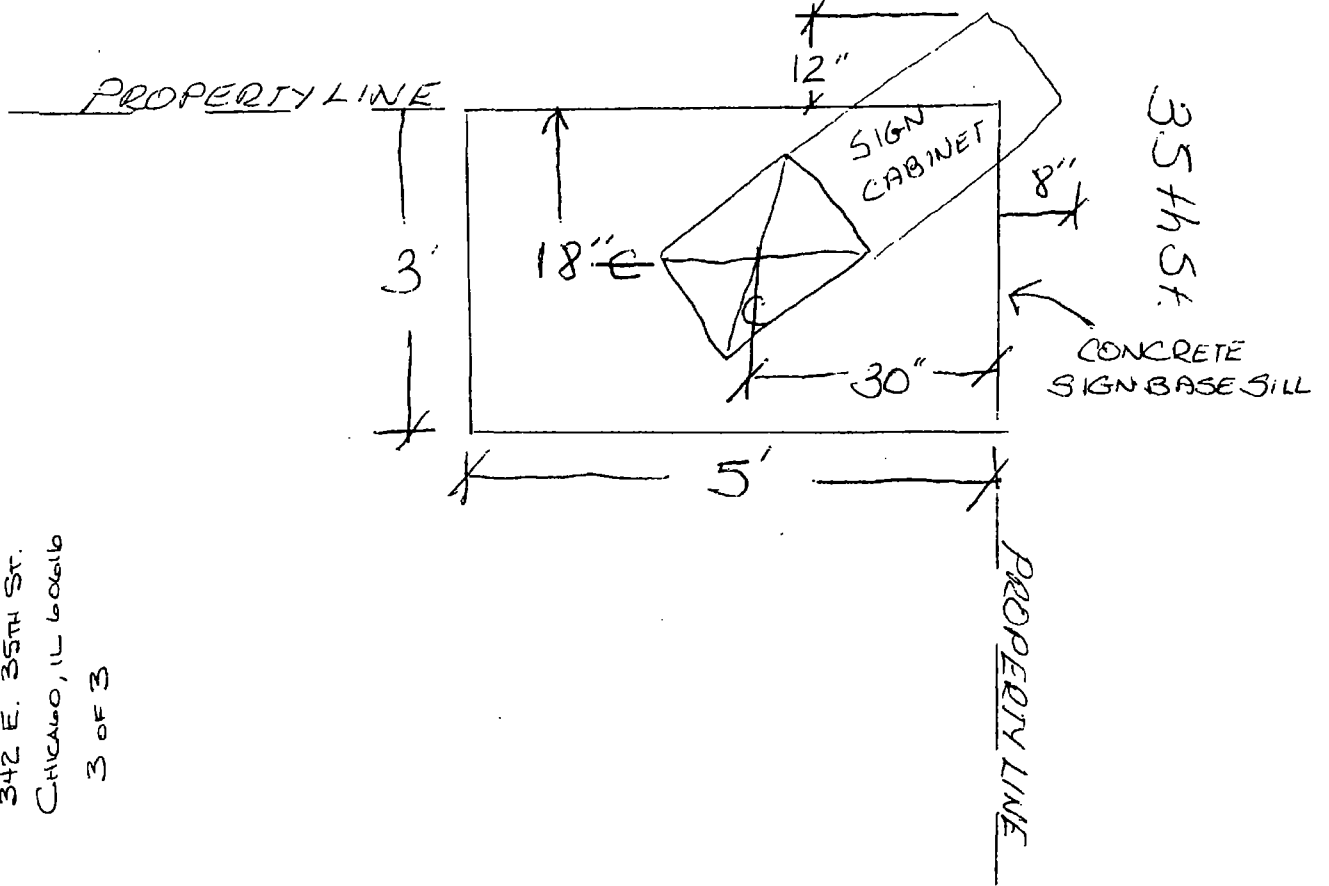

BP/AMOCO
342 E. 35th St.
CHICAGO, IL 60616
3 OF 3

BP AMOCO
342 E. 35th St
CHICAGO, IL

Date 12-10-08
Drawn By PEF
Notes 2 of 3
Job/Location BP AMOCO
Address 342 E. 35th St
City State Zip CHICAGO, IL 60616

ROAD SIGN

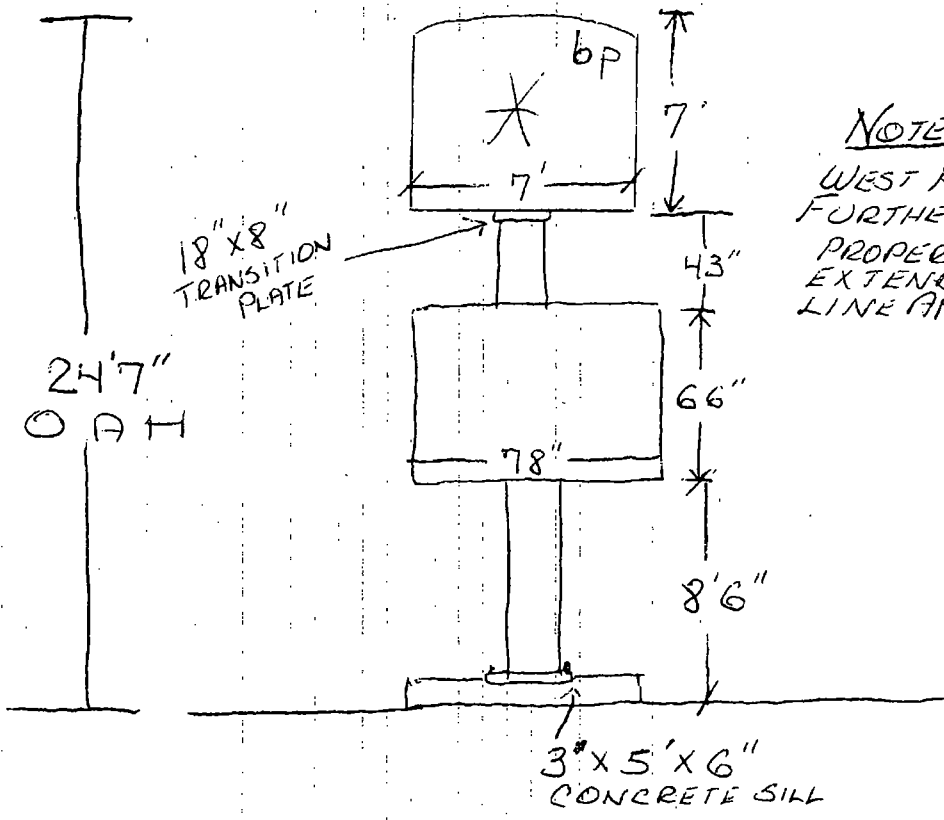

NOTE:
WEST PRICE BOARD
FURTHEST TO
PROPERTY LINE
EXTENDS OVER
LINE APPROX. 8"

Date 12-10-08

Drawn By PATE

Notes 1 of 3

Job/Location BP/AMOCO

Address 342 E. 35TH ST.

City State Zip CHICAGO, IL 60616



BP Amoco
342 E. 35th St
CHICAGO, IL

SITE PLAN
MLK DR.



CURB

* WEST PRICEBOARD
PROJECTS APPROX. 8"
OVER SIDEWALK 35th ST
* EAST PRICEBOARD
12" OVER
MLK DR. SIDEWALK

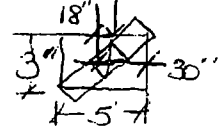

35th ST

7'
SIDEWALK

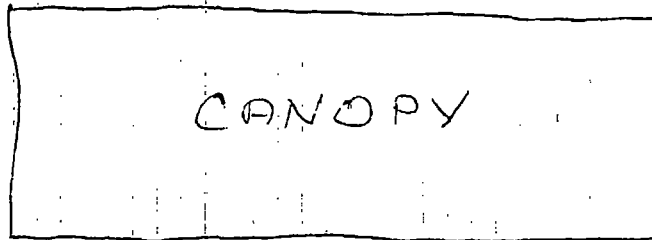



05/28/2014

Alderman **Bob Fioretti**
Ward # **02**
City of Chicago
City Hall, Room **300**
121 North LaSalle Street
Chicago, Illinois 60602

Re: An ordinance to use and maintain a portion of the public right-of-way for **two (2) sign(s)** for **36TH AND KING DRIVE INC AMOCO**, adjacent to the premises known as **342 E. 35th St.**

Dear Alderman **Bob Fioretti**:

The applicant referenced above has requested the use of the public right-of-way for a **sign(s)**. An ordinance has been prepared by the Department of Business Affairs and Consumer Protection – Small Business Center - Public Way Use Unit for presentation to the City Council. Because this request was made for properties located in your ward, as approved by you as per the attached, I respectfully request that you introduce the attached ordinance at the next City Council meeting.

If you have any questions regarding this ordinance, please contact Anthony Bertuca at (312) 744-5506.

Department of Business Affairs and Consumer Protection



City of Chicago



O2014-4433

Office of the City Clerk

Document Tracking Sheet

| | |
|---------------------------------|---|
| Meeting Date: | 5/28/2014 |
| Sponsor(s): | Fioretti (2) |
| Type: | Ordinance |
| Title: | Grant(s) of privilege in public way for 303 Madison - roof soffit |
| Committee(s) Assignment: | Committee on Transportation and Public Way |

ORDINANCE
303 MADISON
Acct. No. 389059 - 1
Permit No. 1111929

Be It Ordained by the City Council of the City of Chicago:

SECTION 1. Permission and authority are hereby given and granted to 303 MADISON, upon the terms and subject to the conditions of this ordinance to maintain and use, as now constructed, one (1) Roof Soffit projecting over the public right-of-way adjacent to its premises known as 303 W. Madison St..

Said Roof Soffit at W. Madison Street measure(s):

One (1) at sixty-four (64) feet in length, and one point one six (1.16) foot in width for a total of seventy-four point two four (74.24) square feet. Existing roof soffit is approximately three hundred feet above grade level.

The location of said privilege shall be as shown on prints kept on file with the Department of Business Affairs and Consumer Protection and the Office of the City Clerk.

Said privilege shall be constructed in accordance with plans and specifications approved by the Department of Transportation (Division of Project Development).

This grant of privilege in the public way shall be subject to the provisions of Section 10-28-015 and all other required provisions of the Municipal Code of Chicago.

The grantee shall pay to the City of Chicago as compensation for the privilege #1111929 herein granted the sum of four hundred (\$400.00) per annum in advance.

A 25% penalty will be added for payments received after due date.

The permit holder agrees to hold the City of Chicago harmless for any damage, relocation or replacement costs associated with damage, relocation or removal of private property caused by the City performing work in the public way.

Authority herein given and granted for a period of five (5) years from and after 02/11/2014.

Alderman

Bob Fioretti 2nd Ward

SOFFIT MADISON





05/28/2014

Alderman Bob Fioretti
Ward # **02**
City of Chicago
City Hall, Room **300**
121 North LaSalle Street
Chicago, Illinois 60602

Re: An ordinance to use and maintain a portion of the public right-of-way for **one (1) soffit(s)** for **303 MADISON**, adjacent to the premises known as **303 W. Madison St.**

Dear Alderman **Bob Fioretti**:

The applicant referenced above has requested the use of the public right-of-way for a **soffit(s)**. An ordinance has been prepared by the Department of Business Affairs and Consumer Protection – Small Business Center - Public Way Use Unit for presentation to the City Council. Because this request was made for properties located in your ward, as approved by you as per the attached, I respectfully request that you introduce the attached ordinance at the next City Council meeting.

If you have any questions regarding this ordinance, please contact Anthony Bertuca at (312) 744-5506.

Department of Business Affairs and Consumer Protection



City of Chicago



O2014-4436

Office of the City Clerk

Document Tracking Sheet

| | |
|---------------------------------|--|
| Meeting Date: | 5/28/2014 |
| Sponsor(s): | Fioretti (2) |
| Type: | Ordinance |
| Title: | Grant(s) of privilege in public way for 303 Madison - vaults |
| Committee(s) Assignment: | Committee on Transportation and Public Way |

ORDINANCE
303 MADISON
Acct. No. 389059 - 1
Permit No. 1111930

Be It Ordained by the City Council of the City of Chicago:

SECTION 1. Permission and authority are hereby given and granted to 303 MADISON, upon the terms and subject to the conditions of this ordinance to maintain and use, as now constructed, two (2) Vault(s) under the public right-of-way adjacent to its premises known as 303 W. Madison St..

Said Vault(s) at S. Franklin Street measure(s):

One (1) at one hundred two (102) feet in length, and eleven (11) feet in width for a total of one thousand one hundred twenty-two (1122) square feet.

Said Vault(s) at W. Madison Street measure(s):

One (1) at sixty-four (64) feet in length, and fifteen (15) feet in width for a total of nine hundred sixty (960) square feet.

The location of said privilege shall be as shown on prints kept on file with the Department of Business Affairs and Consumer Protection and the Office of the City Clerk.

Said privilege shall be constructed in accordance with plans and specifications approved by the Department of Transportation (Office of Underground Coordination).

This grant of privilege in the public way shall be subject to the provisions of Section 10-28-015 and all other required provisions of the Municipal Code of Chicago.

The grantee shall pay to the City of Chicago as compensation for the privilege #1111930 herein granted the sum of thirteen thousand three hundred twenty-five (\$13,325.00) per annum in advance.

A 25% penalty will be added for payments received after due date.

The permit holder agrees to hold the City of Chicago harmless for any damage, relocation or replacement costs associated with damage, relocation or removal of private property caused by the City performing work in the public way.

Authority herein given and granted for a period of five (5) years from and after 02/11/2014.

Alderman

Bob Fioretti 2nd Ward

2 VAULTS
FRANKLIN VAULT 102 X 11
MADISON VAULT 64 X 15

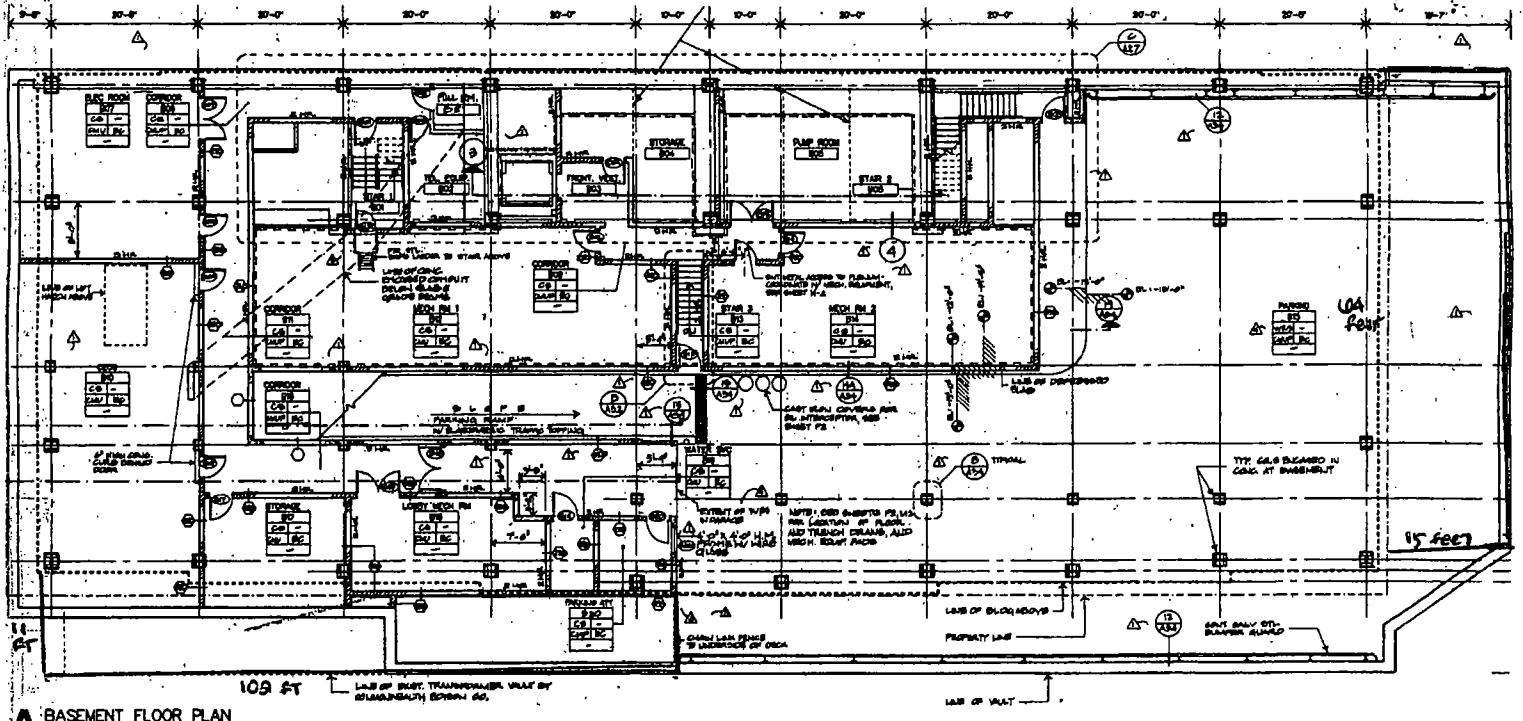

A BASEMENT FLOOR PLAN
SCALE: 1/8"=1'-0"



05/28/2014

Alderman Bob Fioretti
Ward # 02
City of Chicago
City Hall, Room 300
121 North LaSalle Street
Chicago, Illinois 60602

Re: An ordinance to use and maintain a portion of the public right-of-way for **two (2) vault(s)** for **303 MADISON**, adjacent to the premises known as **303 W. Madison St.**

Dear Alderman **Bob Fioretti**:

The applicant referenced above has requested the use of the public right-of-way for **vault(s)**. An ordinance has been prepared by the Department of Business Affairs and Consumer Protection– Small Business Center- Public Way Use Unit for presentation to the City Council. Because this request was made for properties located in your ward, as approved by you as per the attached, I respectfully request that you introduce the attached ordinance at the next City Council meeting.

If you have any questions regarding this ordinance, please contact Anthony Bertuca at (312) 744-5506.

Department of Business Affairs and Consumer Protection



City of Chicago



O2014-4447

Office of the City Clerk

Document Tracking Sheet

Meeting Date: 5/28/2014

Sponsor(s): Fioretti (2)

Type: Ordinance

Title: Grant(s) of privilege in public way for 1720 S Michigan
Condo - balconies

Committee(s) Assignment: Committee on Transportation and Public Way

ORDINANCE
1720 S. MICHIGAN CONDOMINIUMS
Acct. No. 389791 - 1
Permit No. 1112579

Be It Ordained by the City Council of the City of Chicago:

SECTION 1. Permission and authority are hereby given and granted to 1720 S. MICHIGAN CONDOMINIUMS, upon the terms and subject to the conditions of this ordinance to maintain and use, as now constructed, two (2) Balcony(s) projecting over the public right-of-way adjacent to its premises known as 1720 S. Michigan Ave..

Said Balcony(s) at S. MICHIGAN measure(s):

One (1) at two hundred ten point two five (210.25) feet in length, and two point nine one (2.91) feet in width for a total of six hundred eleven point eight three (611.83) square feet. Existing balcony is approximately sixty-five (65) feet above grade level.

Said Balcony(s) at S. MICHIGAN measure(s):

One (1) at one hundred ninety-two point five (192.5) feet in length, and two point nine one (2.91) feet in width for a total of five hundred sixty point one eight (560.18) square feet. Existing balcony is approximately fourteen (14) feet three (3) inches above grade level.

The location of said privilege shall be as shown on prints kept on file with the Department of Business Affairs and Consumer Protection and the Office of the City Clerk.

Said privilege shall be constructed in accordance with plans and specifications approved by the Department of Planning and Development and Department of Transportation (Division of Project Development).

This grant of privilege in the public way shall be subject to the provisions of Section 10-28-015 and all other required provisions of the Municipal Code of Chicago.

The grantee shall pay to the City of Chicago as compensation for the privilege #1112579 herein granted the sum of one hundred fifty (\$150.00) per annum in advance.

A 25% penalty will be added for payments received after due date.

The permit holder agrees to hold the City of Chicago harmless for any damage, relocation or replacement costs associated with damage, relocation or removal of private property caused by the City performing work in the public way.

Authority herein given and granted for a period of five (5) years from and after 07/26/2011.

Alderman

Bob Fieretti 2nd Ward

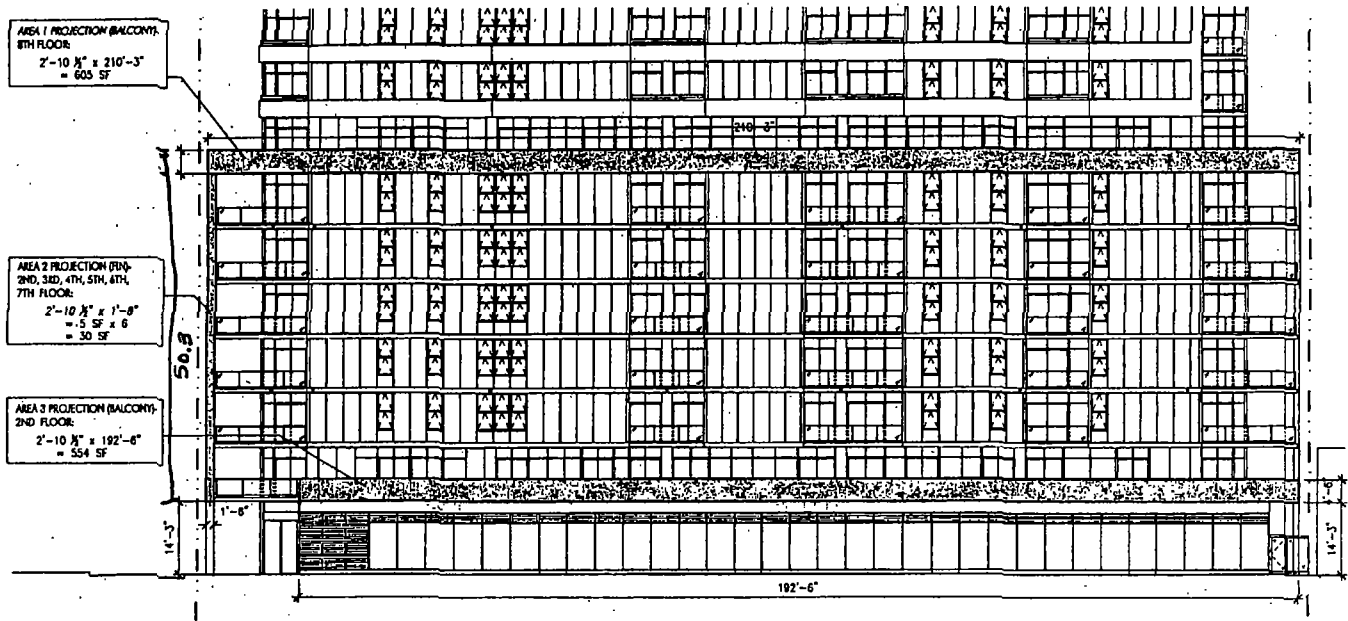

EAST ELEVATION - 1/16" = 1'-0"

1712 S. MICHIGAN DEVELOPMENT CORP.
Dec 05.15.2006

1720 S. MICHIGAN AVENUE

BRININSTOOL + LYNCH, LTD.
ARCHITECTS
© 2005 BRININSTOOL + LYNCH, LTD.



05/28/2014

Alderman Bob Fioretti
Ward # 02
City of Chicago
City Hall, Room 300
121 North LaSalle Street
Chicago, Illinois 60602

Re: An ordinance to use and maintain a portion of the public right-of-way for **two (2) balcony(ies)** for **1720 S. MICHIGAN CONDOMINIUMS**, adjacent to the premises known as **1720 S. Michigan Ave.**

Dear Alderman **Bob Fioretti**:

The applicant referenced above has requested the use of the public right-of-way for a **balcony(ies)**. An ordinance has been prepared by the Department of Business Affairs and Consumer Protection – Small Business Center - Public Way Use Unit for presentation to the City Council. Because this request was made for properties located in your ward, as approved by you as per the attached, I respectfully request that you introduce the attached ordinance at the next City Council meeting.

If you have any questions regarding this ordinance, please contact Anthony Bertuca at (312) 744-5506.

Department of Business Affairs and Consumer Protection



City of Chicago



O2014-4483

Office of the City Clerk

Document Tracking Sheet

| | |
|---------------------------------|---|
| Meeting Date: | 5/28/2014 |
| Sponsor(s): | Fioretti (2) |
| Type: | Ordinance |
| Title: | Grant(s) of privilege in public way for 1720 S Michigan Condo - planters |
| Committee(s) Assignment: | Committee on Transportation and Public Way |

ORDINANCE
1720 S. MICHIGAN CONDOMINIUMS
Acct. No. 389791 - 1
Permit No. 1112580

Be It Ordained by the City Council of the City of Chicago:

SECTION 1. Permission and authority are hereby given and granted to 1720 S. MICHIGAN CONDOMINIUMS, upon the terms and subject to the conditions of this ordinance to maintain and use, as now constructed, five (5) Planter(s) on the public right-of-way for beautification purposes adjacent to its premises known as 1720 S. Michigan Ave..

Said Planter(s) at S. MICHIGAN AVENUE measure(s):

Four (4) at twenty-four (24) feet in length, and five (5) feet in width for a total of four hundred eighty (480) square feet.

One (1) at ten (10) feet in length, and five (5) feet in width for a total of fifty (50) square feet.

Grantee must allow the required clear and unobstructed space for pedestrian passage at all times per rules and regulations approved by the Department of Transportation.

The location of said privilege shall be as shown on prints kept on file with the Department of Business Affairs and Consumer Protection and the Office of the City Clerk.

Said privilege shall be constructed in accordance with plans and specifications approved by the Department of Planning and Development and Department of Transportation (Division of Project Development).

This grant of privilege in the public way shall be subject to the provisions of Section 10-28-015 and all other required provisions of the Municipal Code of Chicago.

The grantee shall pay to the City of Chicago as compensation for the privilege #1112580 herein granted the sum of zero (\$.00) per annum in advance.

A 25% penalty will be added for payments received after due date.

The permit holder agrees to hold the City of Chicago harmless for any damage, relocation or replacement costs associated with damage, relocation or removal of private property caused by the City performing work in the public way.

Authority herein given and granted for a period of five (5) years from and after 5/9/2012.

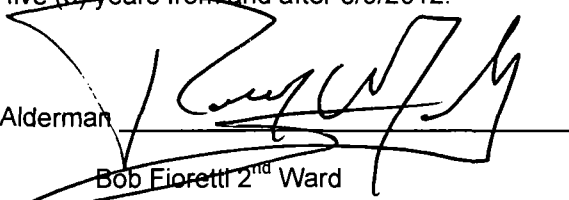
Alderman 
Bob Fioretti 2nd Ward

(Page

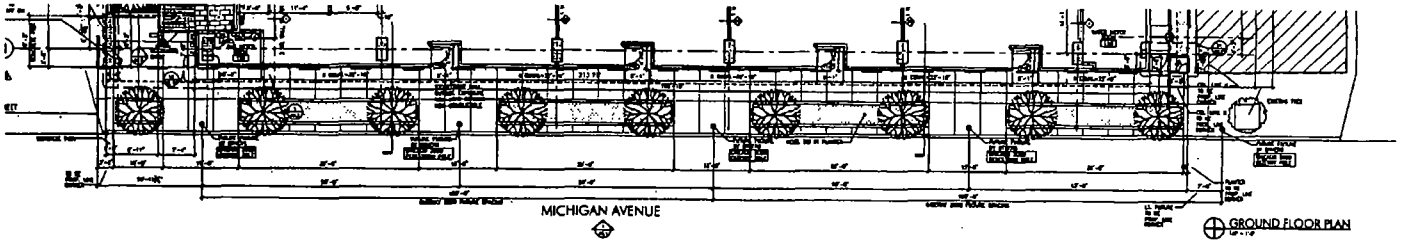

(Page

(Page 3 of 3)

(Page 3 of

(Page



Department of Business Affairs and Consumer Protection
Small Business Center- Public Way Use Unit
City Hall- 121 N. LaSalle Street Room 800 • Chicago, IL 60602
(312)-74-GOBIZ (312-744-6249) • (312) 744-1944 (TTY)
<http://www.cityofchicago.org/bacp>

05/28/2014

Alderman Bob Fioretti
Ward # **02**
City of Chicago
City Hall, Room **300**
121 North LaSalle Street
Chicago, Illinois 60602

Re: An ordinance to use and maintain a portion of the public right-of-way for **five (5) planter(s)** for **1720 S. MICHIGAN CONDOMINIUMS**, adjacent to the premises known as **1720 S. Michigan Ave.**.

Dear Alderman **Bob Fioretti**:

The applicant referenced above has requested the use of the public right-of-way for **planter(s)**. An ordinance has been prepared by the Department of Business Affairs and Consumer Protection – Small Business Center - Public Way Use Unit for presentation to the City Council. Because this request was made for properties located in your ward, as approved by you as per the attached, I respectfully request that you introduce the attached ordinance at the next City Council meeting.

If you have any questions regarding this ordinance, please contact Anthony Bertuca at (312) 744-5506.

Department of Business Affairs and Consumer Protection



City of Chicago



O2014-4492

Office of the City Clerk

Document Tracking Sheet

| | |
|---------------------------------|---|
| Meeting Date: | 5/28/2014 |
| Sponsor(s): | Hairston (5) |
| Type: | Ordinance |
| Title: | Grant(s) of privilege in public way for University of Chicago - caissons |
| Committee(s) Assignment: | Committee on Transportation and Public Way |

ORDINANCE
UNIVERSITY OF CHICAGO
Acct. No. 43697 - 120
Permit No. 1112318

Be It Ordained by the City Council of the City of Chicago:

SECTION 1. Permission and authority are hereby given and granted to UNIVERSITY OF CHICAGO, upon the terms and subject to the conditions of this ordinance to construct, install, maintain and use four (4) Caisson(s) under the public right-of-way adjacent to its premises known as 5500 S. University Ave..

Said Caisson(s) at S. University Avenue measure(s):

Two (2) at eleven point five (11.5) feet in length, and two point three three (2.33) feet in width for a total of fifty-three point five nine (53.59) square feet. Said caissons shall be approximately thirty-two (32) feet below grade level.

One (1) at eight (8) feet in length, and point five eight (.58) feet in width for a total of four point six four (4.64) square feet. Said caisson shall be approximately thirty-two (32) feet below grade level.

One (1) at six point five (6.5) feet in length, and point three three (.33) feet in width for a total of two point one five (2.15) square feet. Said caisson shall be approximately thirty-two (32) feet below grade level.

The location of said privilege shall be as shown on prints kept on file with the Department of Business Affairs and Consumer Protection and the Office of the City Clerk.

Said privilege shall be constructed in accordance with plans and specifications approved by the Department of Planning and Development and Department of Transportation (Office of Underground Coordination).

This grant of privilege in the public way shall be subject to the provisions of Section 10-28-015 and all other required provisions of the Municipal Code of Chicago.

The grantee shall pay to the City of Chicago as compensation for the privilege #1112318 herein granted the sum of four hundred (\$400.00) per annum in advance.

A 25% penalty will be added for payments received after due date.

The permit holder agrees to hold the City of Chicago harmless for any damage, relocation or replacement costs associated with damage, relocation or removal of private property caused by the City performing work in the public way.

Authority herein given and granted for a period of five (5) years from and after Date of Passage.

Alderman 

Leslie Hairston 5th Ward

Caisson Bell Schedule

| Name | Area (Ft ²) |
|------|-------------------------|
| DP 1 | 33.18 |
| DP 2 | 50.27 |
| DP 5 | 103.87 |

⑤ DRILLED PIER SCHEDULE

REVISIONS

| NO. | DATE | DESCRIPTION |
|-----|------|-------------|
| | | |
| | | |
| | | |

| NO. | DATE | DESCRIPTION |
|-----|------|-------------|
| | | |
| | | |
| | | |
| | | |
| | | |
| | | |

INTERFERING CONSTRUCTION

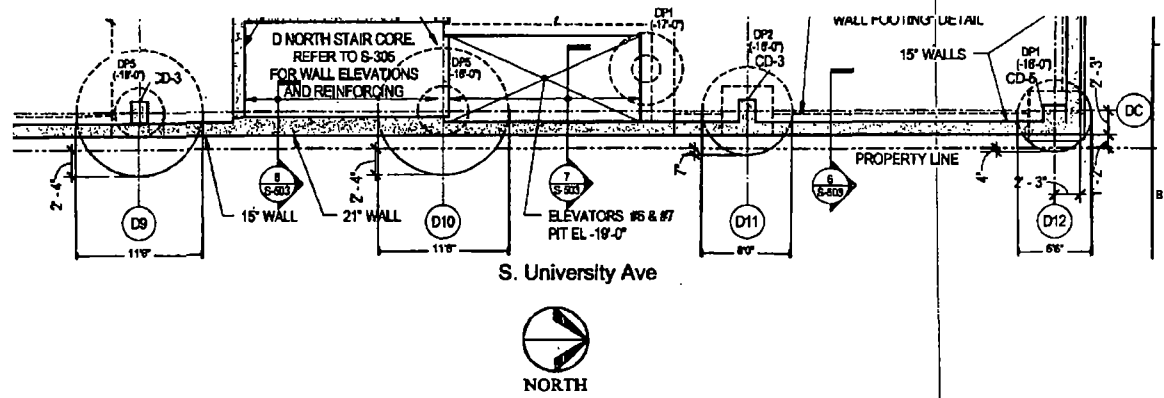

CAISSON PLAN - USE OF PUBLIC WAY
5500 S. University Ave. Chicago, IL 60615

Use of Public Way Plan



City of Chicago



O2014-4513

Office of the City Clerk

Document Tracking Sheet

| | |
|---------------------------------|---|
| Meeting Date: | 5/28/2014 |
| Sponsor(s): | Hairston (5) |
| Type: | Ordinance |
| Title: | Grant(s) of privilege in public way for University of Chicago - sheeting |
| Committee(s) Assignment: | Committee on Transportation and Public Way |

ORDINANCE
UNIVERSITY OF CHICAGO
Acct. No. 43697 - 120
Permit No. 1112319

Be It Ordained by the City Council of the City of Chicago:

SECTION 1. Permission and authority are hereby given and granted to UNIVERSITY OF CHICAGO, upon the terms and subject to the conditions of this ordinance to construct, install, maintain and use one (1) Sheeting(s) under the public right-of-way adjacent to its premises known as 5500 S. University Ave..

Said Sheeting(s) at S. University Avenue measure(s):

One (1) at one hundred fifty-eight (158) feet in length, and three point six seven (3.67) feet in width for a total of five hundred seventy-nine point eight six (579.86) square feet. Said sheeting shall be approximately sixty (60) feet below grade level.

The location of said privilege shall be as shown on prints kept on file with the Department of Business Affairs and Consumer Protection and the Office of the City Clerk.

Said privilege shall be constructed in accordance with plans and specifications approved by the Department of Planning and Development and Department of Transportation (Office of Underground Coordination).

This grant of privilege in the public way shall be subject to the provisions of Section 10-28-015 and all other required provisions of the Municipal Code of Chicago.

The grantee shall pay to the City of Chicago as compensation for the privilege #1112319 herein granted the sum of four hundred (\$400.00) per annum in advance.

A 25% penalty will be added for payments received after due date.

The permit holder agrees to hold the City of Chicago harmless for any damage, relocation or replacement costs associated with damage, relocation or removal of private property caused by the City performing work in the public way.

Authority herein given and granted for a period of five (5) years from and after Date of Passage.

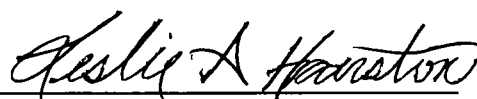
Alderman 

Leslie Hairston 5th Ward

(Page

(Page

(Page

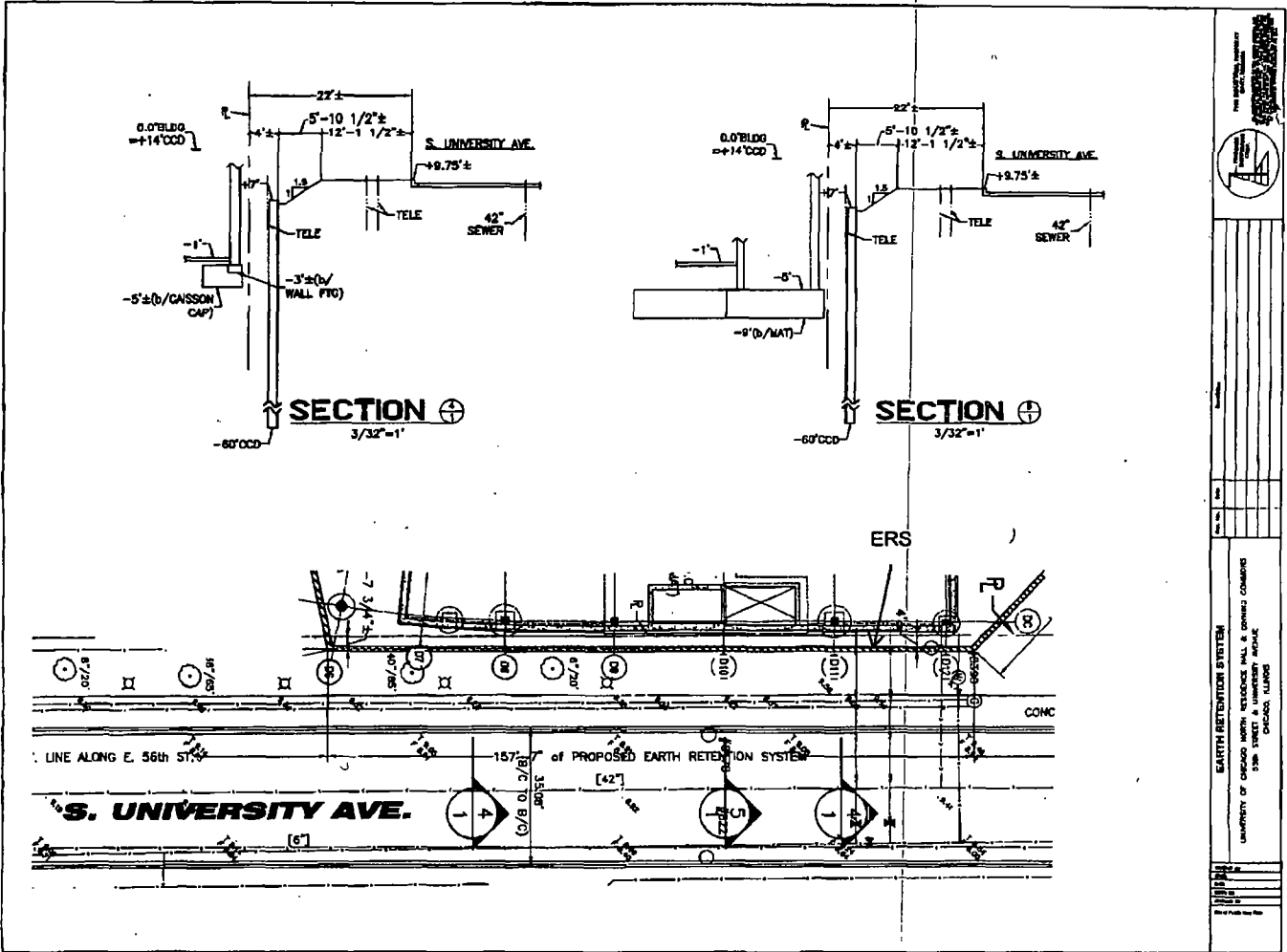



City of Chicago



O2014-4516

Office of the City Clerk

Document Tracking Sheet

| | |
|---------------------------------|---|
| Meeting Date: | 5/28/2014 |
| Sponsor(s): | Hairston (5) |
| Type: | Ordinance |
| Title: | Grant(s) of privilege in public way for University of Chicago Medical Center |
| Committee(s) Assignment: | Committee on Transportation and Public Way |

ORDINANCE
UNIVERSITY OF CHICAGO MEDICAL CENTER¹
Acct. No. 6533 - 14
Permit No. 1112310

Be It Ordained by the City Council of the City of Chicago:

SECTION 1. Permission and authority are hereby given and granted to UNIVERSITY OF CHICAGO MEDICAL CENTER, upon the terms and subject to the conditions of this ordinance to maintain and use, as now constructed, three (3) Sheeting(s) under the public right-of-way adjacent to its premises known as 5700 S. Maryland Ave..

Said Sheeting(s) at S. Drexel Avenue measure(s):

One (1) at one hundred eighty-seven point eight three (187.83) feet in length, and one (1) foot in width for a total of one hundred eighty-seven point eight three (187.83) square feet. Existing sheeting is approximately twenty-five (25) feet in depth.

Said Sheeting(s) at E. 57th Street measure(s):

One (1) at five hundred seventy-six point two five (576.25) feet in length, and one (1) foot in width for a total of five hundred seventy-six point two five (576.25) square feet. Existing sheeting is approximately twenty-five (25) feet in depth.

Said Sheeting(s) at S. Cottage Grove Avenue measure(s):

One (1) at two hundred forty-nine (249) feet in length, and one (1) foot in width for a total of two hundred forty-nine (249) square feet. Existing sheeting is approximately thirty (30) feet in depth.

The location of said privilege shall be as shown on prints kept on file with the Department of Business Affairs and Consumer Protection and the Office of the City Clerk.

Said privilege shall be constructed in accordance with plans and specifications approved by the Department of Planning and Development and Department of Transportation (Office of Underground Coordination).

This grant of privilege in the public way shall be subject to the provisions of Section 10-28-015 and all other required provisions of the Municipal Code of Chicago.

The grantee shall pay to the City of Chicago as compensation for the privilege #1112310 herein granted the sum of one thousand two hundred (\$1,200.00) per annum in advance.

A 25% penalty will be added for payments received after due date.

The permit holder agrees to hold the City of Chicago harmless for any damage, relocation or replacement costs associated with damage, relocation or removal of private property caused by the City performing work in the public way.

Authority herein given and granted for a period of five (5) years from and after 02/11/2014.

Alderman 

Leslie Hairston 5th Ward

CHICAGO GUARANTEE SURVEY COMPANY PLAT OF SURVEY

SCALE 1"=60'

N

PARCEL 1

CONTAINING 100,000 SQ. FT. OF LAND BEING 50 FEET WIDE BY 2,000 FEET LONG

PARCEL 2

CONTAINING 100,000 SQ. FT. OF LAND BEING 50 FEET WIDE BY 2,000 FEET LONG

PARCEL 3

CONTAINING 100,000 SQ. FT. OF LAND BEING 50 FEET WIDE BY 2,000 FEET LONG

PARCEL 4

CONTAINING 100,000 SQ. FT. OF LAND BEING 50 FEET WIDE BY 2,000 FEET LONG

PARCEL 5

CONTAINING 100,000 SQ. FT. OF LAND BEING 50 FEET WIDE BY 2,000 FEET LONG

PARCEL 6

CONTAINING 100,000 SQ. FT. OF LAND BEING 50 FEET WIDE BY 2,000 FEET LONG

PARCEL 7

CONTAINING 100,000 SQ. FT. OF LAND BEING 50 FEET WIDE BY 2,000 FEET LONG

PARCEL 1

CONTAINING 100,000 SQ. FT. OF LAND BEING 50 FEET WIDE BY 2,000 FEET LONG

PARCEL 2

CONTAINING 100,000 SQ. FT. OF LAND BEING 50 FEET WIDE BY 2,000 FEET LONG

PARCEL 3

CONTAINING 100,000 SQ. FT. OF LAND BEING 50 FEET WIDE BY 2,000 FEET LONG

PARCEL 4

CONTAINING 100,000 SQ. FT. OF LAND BEING 50 FEET WIDE BY 2,000 FEET LONG

PARCEL 5

CONTAINING 100,000 SQ. FT. OF LAND BEING 50 FEET WIDE BY 2,000 FEET LONG

PARCEL 6

CONTAINING 100,000 SQ. FT. OF LAND BEING 50 FEET WIDE BY 2,000 FEET LONG

PARCEL 7

CONTAINING 100,000 SQ. FT. OF LAND BEING 50 FEET WIDE BY 2,000 FEET LONG

PARCEL 1

CONTAINING 100,000 SQ. FT. OF LAND BEING 50 FEET WIDE BY 2,000 FEET LONG

PARCEL 2

CONTAINING 100,000 SQ. FT. OF LAND BEING 50 FEET WIDE BY 2,000 FEET LONG

PARCEL 3

CONTAINING 100,000 SQ. FT. OF LAND BEING 50 FEET WIDE BY 2,000 FEET LONG

PARCEL 4

CONTAINING 100,000 SQ. FT. OF LAND BEING 50 FEET WIDE BY 2,000 FEET LONG

PARCEL 5

CONTAINING 100,000 SQ. FT. OF LAND BEING 50 FEET WIDE BY 2,000 FEET LONG

PARCEL 6

CONTAINING 100,000 SQ. FT. OF LAND BEING 50 FEET WIDE BY 2,000 FEET LONG

PARCEL 7

CONTAINING 100,000 SQ. FT. OF LAND BEING 50 FEET WIDE BY 2,000 FEET LONG

PARCEL 1

CONTAINING 100,000 SQ. FT. OF LAND BEING 50 FEET WIDE BY 2,000 FEET LONG

PARCEL 2

CONTAINING 100,000 SQ. FT. OF LAND BEING 50 FEET WIDE BY 2,000 FEET LONG

PARCEL 3

CONTAINING 100,000 SQ. FT. OF LAND BEING 50 FEET WIDE BY 2,000 FEET LONG

PARCEL 4

CONTAINING 100,000 SQ. FT. OF LAND BEING 50 FEET WIDE BY 2,000 FEET LONG

PARCEL 5

CONTAINING 100,000 SQ. FT. OF LAND BEING 50 FEET WIDE BY 2,000 FEET LONG

PARCEL 6

CONTAINING 100,000 SQ. FT. OF LAND BEING 50 FEET WIDE BY 2,000 FEET LONG

PARCEL 7

CONTAINING 100,000 SQ. FT. OF LAND BEING 50 FEET WIDE BY 2,000 FEET LONG

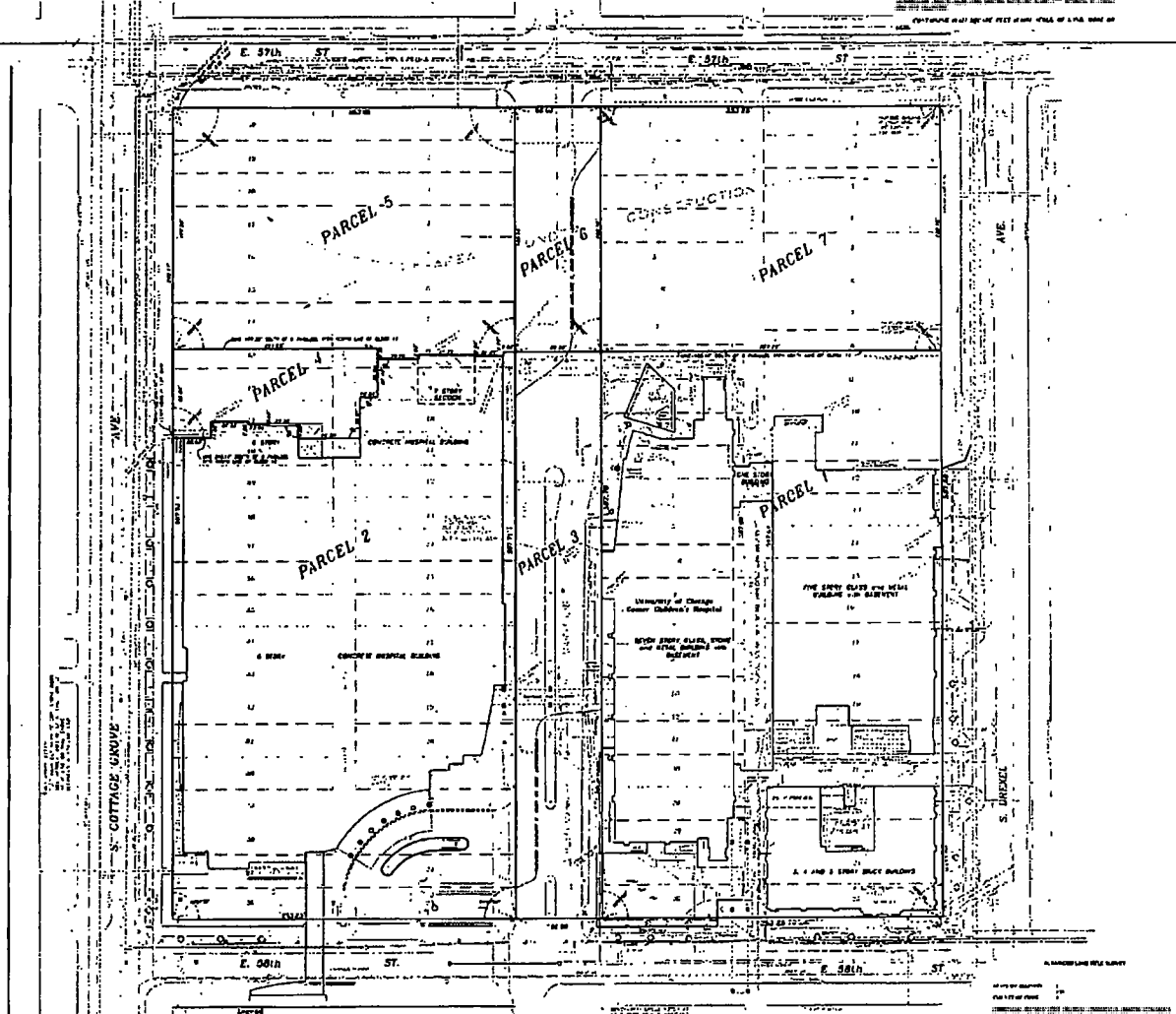

0801002

CHICAGO GUARANTEE SURVEY COMPANY

LEGEND

--- Survey Line

--- Boundary Line

--- Easement Line

--- Right of Way Line

--- Proposed Building Footprint

--- Existing Building Footprint

--- Utility Line

--- Other

NOTES

1. This plat is a true and correct copy of the original survey.

2. The survey was made by the Chicago Guarantee Survey Company.

3. The survey was made on the 1st day of January, 1902.

4. The survey was made by the Chicago Guarantee Survey Company.

5. The survey was made by the Chicago Guarantee Survey Company.

| Parcel | Area (Sq. Ft.) | Dimensions |
|--------|----------------|--------------|
| 1 | 100,000 | 50' x 2,000' |
| 2 | 100,000 | 50' x 2,000' |
| 3 | 100,000 | 50' x 2,000' |
| 4 | 100,000 | 50' x 2,000' |
| 5 | 100,000 | 50' x 2,000' |
| 6 | 100,000 | 50' x 2,000' |
| 7 | 100,000 | 50' x 2,000' |

CHICAGO GUARANTEE SURVEY COMPANY

122 MADISON STREET, CHICAGO, ILL.

INCORPORATED IN ILLINOIS

1902



City of Chicago



O2014-4533

Office of the City Clerk

Document Tracking Sheet

| | |
|---------------------------------|---|
| Meeting Date: | 5/28/2014 |
| Sponsor(s): | Sawyer (6) |
| Type: | Ordinance |
| Title: | Grant(s) of privilege in public way for CBA, Small Business Development, Inc. - 611 E 75th St |
| Committee(s) Assignment: | Committee on Transportation and Public Way |

ORDINANCE
CBA, SMALL BUSINESS DEVELOPMENT, INC
Acct. No. 387282 - 12
Permit No. 1112968

Be It Ordained by the City Council of the City of Chicago:

SECTION 1. Permission and authority are hereby given and granted to CBA, SMALL BUSINESS DEVELOPMENT, INC, upon the terms and subject to the conditions of this ordinance to construct, install, maintain and use two (2) Planter(s) on the public right-of-way for beautification purposes adjacent to its premises known as 611 E. 75th St..

Said Planter(s) at E. 75th Street measure(s):

Two (2) at one (1) foot in length, and four (4) feet in width for a total of eight (8) square feet.

Grantee must allow the required clear and unobstructed space for pedestrian passage at all times per rules and regulations approved by the Department of Transportation.

The location of said privilege shall be as shown on prints kept on file with the Department of Business Affairs and Consumer Protection and the Office of the City Clerk.

Said privilege shall be constructed in accordance with plans and specifications approved by the Department of Planning and Development and Department of Transportation (Division of Project Development).

This grant of privilege in the public way shall be subject to the provisions of Section 10-28-015 and all other required provisions of the Municipal Code of Chicago.

The grantee shall pay to the City of Chicago as compensation for the privilege #1112968 herein granted the sum of zero (\$0.00) per annum in advance.

A 25% penalty will be added for payments received after due date.

The permit holder agrees to hold the City of Chicago harmless for any damage, relocation or replacement costs associated with damage, relocation or removal of private property caused by the City performing work in the public way.

Authority herein given and granted for a period of five (5) years from and after Date of Passage.

Alderman



Roderick T. Sawyer 6th Ward

| 12 | ROUND CONCRETE PLANTERS | \$ | \$ |
|----|--|----|----|
| | Model: RP-48-30 | | \$ |
| | Type: precast reinforced concrete planters | | \$ |
| | diameter: 48" outside diameter | | |
| | height: 30" tall | | |
| | finish: exposed aggregate | | |
| | weight: 1800 pounds each | | |
| | color: to be determined | | |
| | | | |
| | | | |

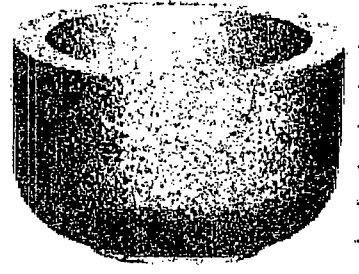

13



05/28/2014

Alderman **Roderick T. Sawyer**
Ward # **06**
City of Chicago
City Hall, Room **300**
121 North LaSalle Street
Chicago, Illinois 60602

Re: An ordinance to use and maintain a portion of the public right-of-way for **two (2) planter(s)** for **CBA, SMALL BUSINESS DEVELOPMENT, INC**, adjacent to the premises known as **611 E. 75th St.**

Dear Alderman **Roderick T. Sawyer**:

The applicant referenced above has requested the use of the public right-of-way for a **planter(s)**. An ordinance has been prepared by the Department of Business Affairs and Consumer Protection – Small Business Center - Public Way Use Unit for presentation to the City Council. Because this request was made for properties located in your ward, as approved by you as per the attached, I respectfully request that you introduce the attached ordinance at the next City Council meeting.

If you have any questions regarding this ordinance, please contact Anthony Bertuca at (312) 744-5506.

Department of Business Affairs and Consumer Protection



City of Chicago



O2014-4543

Office of the City Clerk

Document Tracking Sheet

| | |
|---------------------------------|---|
| Meeting Date: | 5/28/2014 |
| Sponsor(s): | Sawyer (6) |
| Type: | Ordinance |
| Title: | Grant(s) of privilege in public way for CBA, Small Business Development, Inc. - 555 E 75th St |
| Committee(s) Assignment: | Committee on Transportation and Public Way |

ORDINANCE
CBA, SMALL BUSINESS DEVELOPMENT, INC
Acct. No. 387282 - 13
Permit No. 1112969

Be It Ordained by the City Council of the City of Chicago:

SECTION 1. Permission and authority are hereby given and granted to CBA, SMALL BUSINESS DEVELOPMENT, INC, upon the terms and subject to the conditions of this ordinance to construct, install, maintain and use one (1) Planter(s) on the public right-of-way for beautification purposes adjacent to its premises known as 555 E. 75th St..

Said Planter(s) at E. 75th Street measure(s):

One (1) at one (1) foot in length, and four (4) feet in width for a total of four (4) square feet.

Grantee must allow the required clear and unobstructed space for pedestrian passage at all times per rules and regulations approved by the Department of Transportation.

The location of said privilege shall be as shown on prints kept on file with the Department of Business Affairs and Consumer Protection and the Office of the City Clerk.

Said privilege shall be constructed in accordance with plans and specifications approved by the Department of Planning and Development and Department of Transportation (Division of Project Development).

This grant of privilege in the public way shall be subject to the provisions of Section 10-28-015 and all other required provisions of the Municipal Code of Chicago.

The grantee shall pay to the City of Chicago as compensation for the privilege #1112969 herein granted the sum of zero (\$.00) per annum in advance.

A 25% penalty will be added for payments received after due date.

The permit holder agrees to hold the City of Chicago harmless for any damage, relocation or replacement costs associated with damage, relocation or removal of private property caused by the City performing work in the public way.

Authority herein given and granted for a period of five (5) years from and after Date of Passage.

Alderman



Roderick T. Sawyer 6th Ward

| 12 | ROUND CONCRETE PLANTERS | \$ | \$ |
|----|--|----|----|
| | Model: RP-48-30 | | \$ |
| | Type: precast reinforced concrete planters | | \$ |
| | diameter: 48" outside diameter | | |
| | height: 30" tall | | |
| | finish: exposed aggregate | | |
| | weight: 1600 pounds each | | |
| | color: to be determined | | |
| | | | |
| | | | |
| | | | |
| | | | |
| | | | |

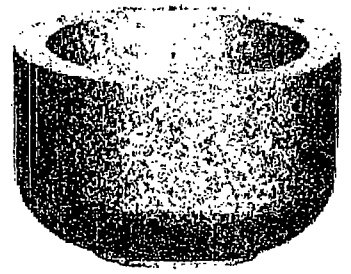

15



05/28/2014

Alderman **Roderick T. Sawyer**
Ward # **06**
City of Chicago
City Hall, Room **300**
121 North LaSalle Street
Chicago, Illinois 60602

Re: An ordinance to use and maintain a portion of the public right-of-way for **one (1) planter(s)** for **CBA, SMALL BUSINESS DEVELOPMENT, INC**, adjacent to the premises known as **555 E. 75th St.**

Dear Alderman **Roderick T. Sawyer**:

The applicant referenced above has requested the use of the public right-of-way for a **planter(s)**. An ordinance has been prepared by the Department of Business Affairs and Consumer Protection – Small Business Center - Public Way Use Unit for presentation to the City Council. Because this request was made for properties located in your ward, as approved by you as per the attached, I respectfully request that you introduce the attached ordinance at the next City Council meeting.

If you have any questions regarding this ordinance, please contact Anthony Bertuca at (312) 744-5506.

Department of Business Affairs and Consumer Protection



City of Chicago



O2014-4545

Office of the City Clerk

Document Tracking Sheet

| | |
|---------------------------------|---|
| Meeting Date: | 5/28/2014 |
| Sponsor(s): | Sawyer (6) |
| Type: | Ordinance |
| Title: | Grant(s) of privilege in public way for CBA, Small Business Development, Inc. - 511 E 75th St |
| Committee(s) Assignment: | Committee on Transportation and Public Way |

ORDINANCE
CBA, SMALL BUSINESS DEVELOPMENT, INC
Acct. No. 387282 - 15
Permit No. 1112973

Be It Ordained by the City Council of the City of Chicago:

SECTION 1. Permission and authority are hereby given and granted to CBA, SMALL BUSINESS DEVELOPMENT, INC, upon the terms and subject to the conditions of this ordinance to construct, install, maintain and use two (2) Planter(s) on the public right-of-way for beautification purposes adjacent to its premises known as 511 E. 75th St..

Said Planter(s) at E. 75th Street measure(s):

Two (2) at one (1) foot in length, and four (4) feet in width for a total of eight (8) square feet.

Grantee must allow the required clear and unobstructed space for pedestrian passage at all times per rules and regulations approved by the Department of Transportation.

The location of said privilege shall be as shown on prints kept on file with the Department of Business Affairs and Consumer Protection and the Office of the City Clerk.

Said privilege shall be constructed in accordance with plans and specifications approved by the Department of Planning and Development and Department of Transportation (Division of Project Development).

This grant of privilege in the public way shall be subject to the provisions of Section 10-28-015 and all other required provisions of the Municipal Code of Chicago.

The grantee shall pay to the City of Chicago as compensation for the privilege #1112973 herein granted the sum of zero (\$0.00) per annum in advance.

A 25% penalty will be added for payments received after due date.

The permit holder agrees to hold the City of Chicago harmless for any damage, relocation or replacement costs associated with damage, relocation or removal of private property caused by the City performing work in the public way.

Authority herein given and granted for a period of five (5) years from and after Date of Passage.

Alderman

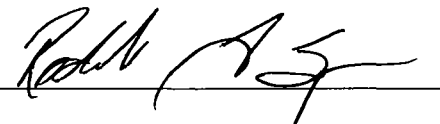

Roderick T. Sawyer 6th Ward

| 12 | ROUND CONCRETE PLANTERS | \$ | \$ |
|----|--|----|----|
| | Model: RP-48-30 | | \$ |
| | Type: precast reinforced concrete planters | | \$ |
| | diameter: 48" outside diameter | | \$ |
| | height: 30" tall | | \$ |
| | finish: exposed aggregate | | \$ |
| | weight: 1600 pounds each | | \$ |
| | color: to be determined | | \$ |
| | | | \$ |
| | | | \$ |
| | | | \$ |

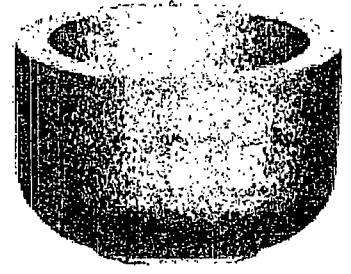

13



05/28/2014

Alderman **Roderick T. Sawyer**
Ward # **06**
City of Chicago
City Hall, Room **300**
121 North LaSalle Street
Chicago, Illinois 60602

Re: An ordinance to use and maintain a portion of the public right-of-way for **two (2) planter(s)** for **CBA, SMALL BUSINESS DEVELOPMENT, INC.**, adjacent to the premises known as **511 E. 75th St.**

Dear Alderman **Roderick T. Sawyer**:

The applicant referenced above has requested the use of the public right-of-way for a **planter(s)**. An ordinance has been prepared by the Department of Business Affairs and Consumer Protection – Small Business Center - Public Way Use Unit for presentation to the City Council. Because this request was made for properties located in your ward, as approved by you as per the attached, I respectfully request that you introduce the attached ordinance at the next City Council meeting.

If you have any questions regarding this ordinance, please contact Anthony Bertuca at (312) 744-5506.

Department of Business Affairs and Consumer Protection



City of Chicago



O2014-4551

Office of the City Clerk

Document Tracking Sheet

| | |
|---------------------------------|---|
| Meeting Date: | 5/28/2014 |
| Sponsor(s): | Sawyer (6) |
| Type: | Ordinance |
| Title: | Grant(s) of privilege in public way for CBA, Small Business Development, Inc. - 457 E 75th St |
| Committee(s) Assignment: | Committee on Transportation and Public Way |

ORDINANCE
CBA, SMALL BUSINESS DEVELOPMENT, INC
Acct. No. 387282 - 16
Permit No. 1112975

Be It Ordained by the City Council of the City of Chicago:

SECTION 1. Permission and authority are hereby given and granted to CBA, SMALL BUSINESS DEVELOPMENT, INC, upon the terms and subject to the conditions of this ordinance to construct, install, maintain and use one (1) Planter(s) on the public right-of-way for beautification purposes adjacent to its premises known as 457 E. 75th St..

Said Planter(s) at E. 75th Street measure(s):

One (1) at one (1) foot in length, and four (4) feet in width for a total of four (4) square feet.

Grantee must allow the required clear and unobstructed space for pedestrian passage at all times per rules and regulations approved by the Department of Transportation.

The location of said privilege shall be as shown on prints kept on file with the Department of Business Affairs and Consumer Protection and the Office of the City Clerk.

Said privilege shall be constructed in accordance with plans and specifications approved by the Department of Planning and Development and Department of Transportation (Division of Project Development).

This grant of privilege in the public way shall be subject to the provisions of Section 10-28-015 and all other required provisions of the Municipal Code of Chicago.

The grantee shall pay to the City of Chicago as compensation for the privilege #1112975 herein granted the sum of zero (\$.00) per annum in advance.

A 25% penalty will be added for payments received after due date.

The permit holder agrees to hold the City of Chicago harmless for any damage, relocation or replacement costs associated with damage, relocation or removal of private property caused by the City performing work in the public way.

Authority herein given and granted for a period of five (5) years from and after Date of Passage.

Alderman

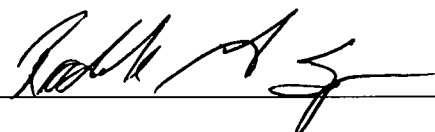

Roderick T. Sawyer 6th Ward

| 12 | ROUND CONCRETE PLANTERS | \$ | \$ |
|----|--|----|----|
| | Model: RP-48-30 | | |
| | Type: precast reinforced concrete planters | | |
| | diameter: 48" outside diameter | | |
| | height: 30" tall | | |
| | finish: exposed aggregate | | |
| | weight: 1500 pounds each | | |
| | color: to be determined | | |
| | | | |
| | | | |

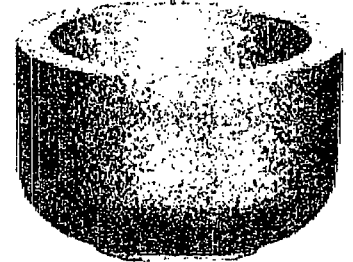

13



05/28/2014

Alderman **Roderick T. Sawyer**
Ward # **06**
City of Chicago
City Hall, Room **300**
121 North LaSalle Street
Chicago, Illinois 60602

Re: An ordinance to use and maintain a portion of the public right-of-way for **one (1) planter(s)** for **CBA, SMALL BUSINESS DEVELOPMENT, INC**, adjacent to the premises known as **457 E. 75th St.**

Dear Alderman **Roderick T. Sawyer**:

The applicant referenced above has requested the use of the public right-of-way for a **planter(s)**. An ordinance has been prepared by the Department of Business Affairs and Consumer Protection – Small Business Center - Public Way Use Unit for presentation to the City Council. Because this request was made for properties located in your ward, as approved by you as per the attached, I respectfully request that you introduce the attached ordinance at the next City Council meeting.

If you have any questions regarding this ordinance, please contact Anthony Bertuca at (312) 744-5506.

Department of Business Affairs and Consumer Protection



City of Chicago

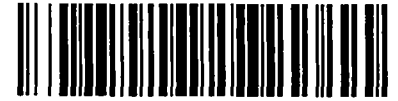

O2014-4558

Office of the City Clerk

Document Tracking Sheet

| | |
|---------------------------------|---|
| Meeting Date: | 5/28/2014 |
| Sponsor(s): | Sawyer (6) |
| Type: | Ordinance |
| Title: | Grant(s) of privilege in public way for CBA, Small Business Development, Inc. - 647 E 75th St |
| Committee(s) Assignment: | Committee on Transportation and Public Way |

ORDINANCE
CBA, SMALL BUSINESS DEVELOPMENT, INC
Acct. No. 387282 - 11
Permit No. 1112489

Be It Ordained by the City Council of the City of Chicago:

SECTION 1. Permission and authority are hereby given and granted to CBA, SMALL BUSINESS DEVELOPMENT, INC, upon the terms and subject to the conditions of this ordinance to construct, install, maintain and use one (1) Planter(s) on the public right-of-way for beautification purposes adjacent to its premises known as 647 E. 75th St..

Said Planter(s) at E. 75th Street measure(s):

One (1) at one (1) foot in length, and four (4) feet in width for a total of four (4) square feet.

Grantee must allow the required clear and unobstructed space for pedestrian passage at all times per rules and regulations approved by the Department of Transportation.

The location of said privilege shall be as shown on prints kept on file with the Department of Business Affairs and Consumer Protection and the Office of the City Clerk.

Said privilege shall be constructed in accordance with plans and specifications approved by the Department of Planning and Development and Department of Transportation (Division of Project Development).

This grant of privilege in the public way shall be subject to the provisions of Section 10-28-015 and all other required provisions of the Municipal Code of Chicago.

The grantee shall pay to the City of Chicago as compensation for the privilege #1112489 herein granted the sum of zero (\$.00) per annum in advance.

A 25% penalty will be added for payments received after due date.

The permit holder agrees to hold the City of Chicago harmless for any damage, relocation or replacement costs associated with damage, relocation or removal of private property caused by the City performing work in the public way.

Authority herein given and granted for a period of five (5) years from and after Date of Passage.

Alderman



Roderick T. Sawyer 6th Ward

| 12 | ROUND CONCRETE PLANTERS | \$ | \$ |
|----|--|----|----|
| | Model: RP-48-30 | | |
| | Type: precast reinforced concrete planters | | |
| | diameter: 48" outside diameter | | |
| | height: 30" tall | | |
| | finish: exposed aggregate | | |
| | weight: 1600 pounds each | | |
| | color: to be determined | | |
| | | | |
| | | | |

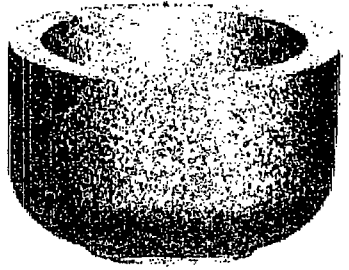

16



05/28/2014

Alderman **Roderick T. Sawyer**
Ward # **06**
City of Chicago
City Hall, Room **300**
121 North LaSalle Street
Chicago, Illinois 60602

Re: An ordinance to use and maintain a portion of the public right-of-way for **one (1) planter(s)** for **CBA, SMALL BUSINESS DEVELOPMENT, INC**, adjacent to the premises known as **647 E. 75th St.**

Dear Alderman **Roderick T. Sawyer**:

The applicant referenced above has requested the use of the public right-of-way for a **planter(s)**. An ordinance has been prepared by the Department of Business Affairs and Consumer Protection – Small Business Center - Public Way Use Unit for presentation to the City Council. Because this request was made for properties located in your ward, as approved by you as per the attached, I respectfully request that you introduce the attached ordinance at the next City Council meeting.

If you have any questions regarding this ordinance, please contact Anthony Bertuca at (312) 744-5506.

Department of Business Affairs and Consumer Protection



City of Chicago



O2014-4560

Office of the City Clerk

Document Tracking Sheet

| | |
|---------------------------------|---|
| Meeting Date: | 5/28/2014 |
| Sponsor(s): | Beale (9) |
| Type: | Ordinance |
| Title: | Grant(s) of privilege in public way for City Sports On Michigan |
| Committee(s) Assignment: | Committee on Transportation and Public Way |

ORDINANCE
CITY SPORTS ON MICHIGAN
Acct. No. 86645 - 3
Permit No. 1109482

Be It Ordained by the City Council of the City of Chicago:

SECTION 1. Permission and authority are hereby given and granted to CITY SPORTS ON MICHIGAN, upon the terms and subject to the conditions of this ordinance to maintain and use one (1) sign(s) projecting over the public right-of-way attached to its premises known as 11102-11106 S. Michigan Ave..

Said sign structure(s) measures as follows; along 111th Street:
One (1) at sixteen point six seven (16.67) feet in length, two (2) feet in height and ten (10) feet above grade level.

The location of said privilege shall be as shown on prints kept on file with the Department of Business Affairs and Consumer Protection and the Office of the City Clerk.

Said privilege shall be constructed in accordance with plans and specifications approved by the Department of Transportation (Division of Project Development) and Zoning Department - Signs.

This grant of privilege in the public way shall be subject to the provisions of Section 10-28-015 and all other required provisions of the Municipal Code of Chicago.

The grantee shall pay to the City of Chicago as compensation for the privilege #1109482 herein granted the sum of three hundred (\$300.00) per annum in advance.

A 25% penalty will be added for payments received after due date.

The permit holder agrees to hold the City of Chicago harmless for any damage, relocation or replacement costs associated with damage, relocation or removal of private property caused by the City performing work in the public way.

Authority herein given and granted for a period of ^{three} ~~five~~ (5) years from and after Date of Passage.

Alderman 
Anthony Beale 9th Ward

16' 8"

CITY SPORTS

2' 0"

INDIVIDUALLY ILLUMINATED CHANNEL LETTER W/ WIREWAY
 LOC: SIDE OF THE STORE
 SPECIFICATIONS

CITY SPORTS

| | |
|--------------|--------------------|
| SIGN TYPE | IND CHANNEL LETTER |
| FACE | ACRYLIC RED |
| RETURNS | BLACK |
| TRIM CAP | BLACK |
| ILLUMINATION | RED LEDS |

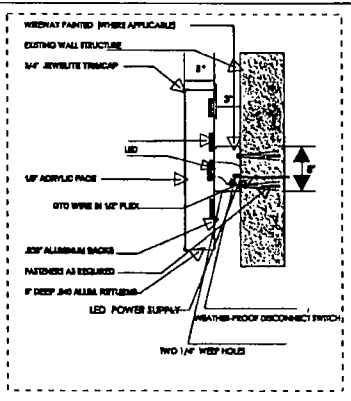

| | | | |
|----------|------------------------------|-----------|----------------|
| Customer | CITY SPORTS | Drawing # | Revision |
| Project | 11102 S. MICHIGAN CHICAGO IL | Date | Date revised |
| Address | | Scale | Scale contract |

750 BONNIE LN ELK GROVE VILLAGE IL 60007

S.M. DELLOUX DESIGN
 847-806-7740 FAX 847-806-7741 SMDLLOUXDESIGN@SBCGLOBAL.NET



City of Chicago



O2014-4564

Office of the City Clerk

Document Tracking Sheet

| | |
|---------------------------------|--|
| Meeting Date: | 5/28/2014 |
| Sponsor(s): | Beale (9) |
| Type: | Ordinance |
| Title: | Grant(s) of privilege in public way for US Furniture & Linen |
| Committee(s) Assignment: | Committee on Transportation and Public Way |

ORDINANCE
U.S. FURNITURE & LINEN
Acct. No. 330171 - 1
Permit No. 1112508

Be It Ordained by the City Council of the City of Chicago:

SECTION 1. Permission and authority are hereby given and granted to U.S. FURNITURE & LINEN, upon the terms and subject to the conditions of this ordinance to maintain and use, as now constructed, one (1) Fire Shutter(s) projecting over the public right-of-way adjacent to its premises known as 11218 S. Michigan Ave..

Said Fire Shutter(s) at S. Michigan measure(s):

One (1) at fifty-one point five (51.5) feet in length, and two point three three (2.33) feet in width for a total of one hundred twenty (120) square feet.

The location of said privilege shall be as shown on prints kept on file with the Department of Business Affairs and Consumer Protection and the Office of the City Clerk.

Said privilege shall be constructed in accordance with plans and specifications approved by the Department of Transportation (Division of Project Development).

This grant of privilege in the public way shall be subject to the provisions of Section 10-28-015 and all other required provisions of the Municipal Code of Chicago.

The grantee shall pay to the City of Chicago as compensation for the privilege #1112508 herein granted the sum of four hundred (\$400.00) per annum in advance.

A 25% penalty will be added for payments received after due date.

The permit holder agrees to hold the City of Chicago harmless for any damage, relocation or replacement costs associated with damage, relocation or removal of private property caused by the City performing work in the public way.

Authority herein given and granted for a period of ^{Three} ~~five~~ (3) years from and after 02/11/2014.

Alderman 
Anthony Beale 9th Ward





City of Chicago



O2014-4569

Office of the City Clerk

Document Tracking Sheet

| | |
|---------------------------------|---|
| Meeting Date: | 5/28/2014 |
| Sponsor(s): | Balcer (11) |
| Type: | Ordinance |
| Title: | Grant(s) of privilege in public way for DSO Properties LLC - bay windows |
| Committee(s) Assignment: | Committee on Transportation and Public Way |

ORDINANCE
DSO PROPERTIES, LLC
Acct. No. 390358 - 1
Permit No. 1113085

Be It Ordained by the City Council of the City of Chicago:

SECTION 1. Permission and authority are hereby given and granted to DSO PROPERTIES, LLC, upon the terms and subject to the conditions of this ordinance to maintain and use, as now constructed, two (2) Bay Window(s) projecting over the public right-of-way adjacent to its premises known as 3252-54 S. Morgan St..

Said Bay Window(s) at S. Morgan Street measure(s):

Two (2) at twelve (12) feet in length, and two point seven five (2.75) feet in width for a total of sixty-six (66) square feet.

The location of said privilege shall be as shown on prints kept on file with the Department of Business Affairs and Consumer Protection and the Office of the City Clerk.

Said privilege shall be constructed in accordance with plans and specifications approved by the Department of Transportation (Division of Project Development).

This grant of privilege in the public way shall be subject to the provisions of Section 10-28-015 and all other required provisions of the Municipal Code of Chicago.

The grantee shall pay to the City of Chicago as compensation for the privilege #1113085 herein granted the sum of one hundred fifty (\$150.00) per annum in advance.

A 25% penalty will be added for payments received after due date.

The permit holder agrees to hold the City of Chicago harmless for any damage, relocation or replacement costs associated with damage, relocation or removal of private property caused by the City performing work in the public way.

Authority herein given and granted for a period of five (5) years from and after Date of Passage.

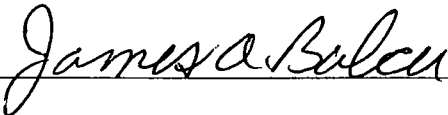
Alderman 
James A. Balcer 11th Ward

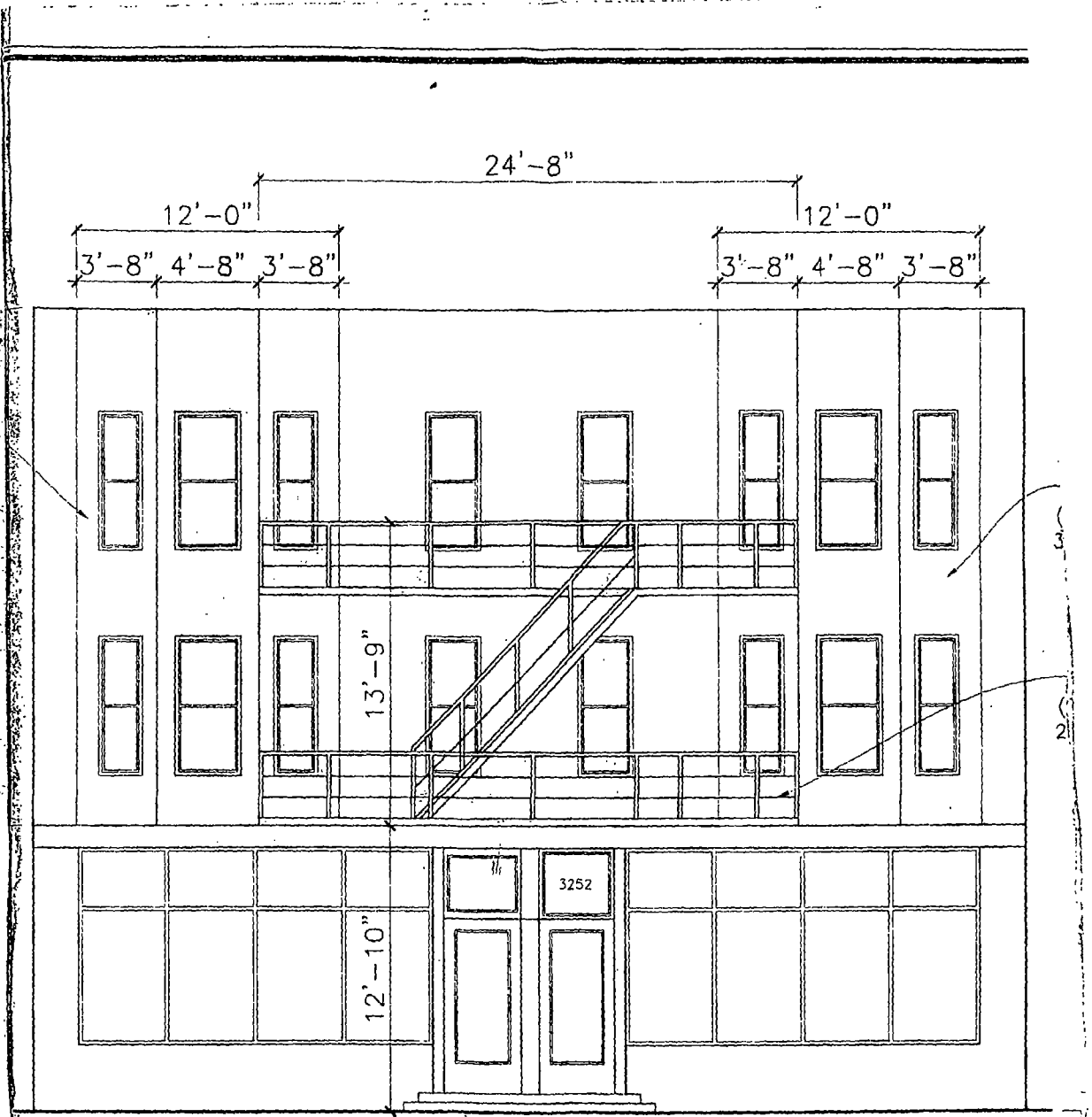

EXISTING
FRONT ELEVATION
SCALE: 3/16"=1'-0"



05/28/2014

Alderman **James A. Balcer**
Ward # 11
City of Chicago
City Hall, Room 203
121 North LaSalle Street
Chicago, Illinois 60602

Re: An ordinance to use and maintain a portion of the public right-of-way for **two (2) bay window(s)** for **DSO PROPERTIES, LLC**, adjacent to the premises known as **3252-54 S. Morgan St.**

Dear Alderman **James A. Balcer**:

The applicant referenced above has requested the use of the public right-of-way for a **bay window(s)**. An ordinance has been prepared by the Department of Business Affairs and Consumer Protection – Small Business Center - Public Way Use Unit for presentation to the City Council. Because this request was made for properties located in your ward, as approved by you as per the attached, I respectfully request that you introduce the attached ordinance at the next City Council meeting.

If you have any questions regarding this ordinance, please contact Anthony Bertuca at (312) 744-5506.

Department of Business Affairs and Consumer Protection



City of Chicago



O2014-4585

Office of the City Clerk

Document Tracking Sheet

| | |
|---------------------------------|---|
| Meeting Date: | 5/28/2014 |
| Sponsor(s): | Balcer (11) |
| Type: | Ordinance |
| Title: | Grant(s) of privilege in public way for DSO Properties LLC - fire escape |
| Committee(s) Assignment: | Committee on Transportation and Public Way |

ORDINANCE
DSO PROPERTIES, LLC
Acct. No. 390358 - 1
Permit No. 1113086

Be It Ordained by the City Council of the City of Chicago:

SECTION 1. Permission and authority are hereby given and granted to DSO PROPERTIES, LLC, upon the terms and subject to the conditions of this ordinance to maintain and use, as now constructed, one (1) Fire Escape(s) projecting over the public right-of-way adjacent to its premises known as 3252-54 S. Morgan St..

Said Fire Escape(s) at S. Morgan Street measure(s):

One (1) at twenty-four point five eight (24.58) feet in length, and four point nine two (4.92) feet in width for a total of one hundred twenty point nine three (120.93) square feet.

The location of said privilege shall be as shown on prints kept on file with the Department of Business Affairs and Consumer Protection and the Office of the City Clerk.

Said privilege shall be constructed in accordance with plans and specifications approved by the Department of Transportation (Division of Project Development).

This grant of privilege in the public way shall be subject to the provisions of Section 10-28-015 and all other required provisions of the Municipal Code of Chicago.

The grantee shall pay to the City of Chicago as compensation for the privilege #1113086 herein granted the sum of four hundred (\$400.00) per annum in advance.

A 25% penalty will be added for payments received after due date.

The permit holder agrees to hold the City of Chicago harmless for any damage, relocation or replacement costs associated with damage, relocation or removal of private property caused by the City performing work in the public way.

Authority herein given and granted for a period of five (5) years from and after Date of Passage.

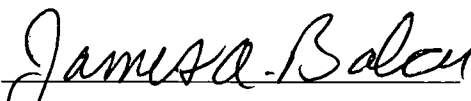
Alderman 
James A. Balcer 11th Ward

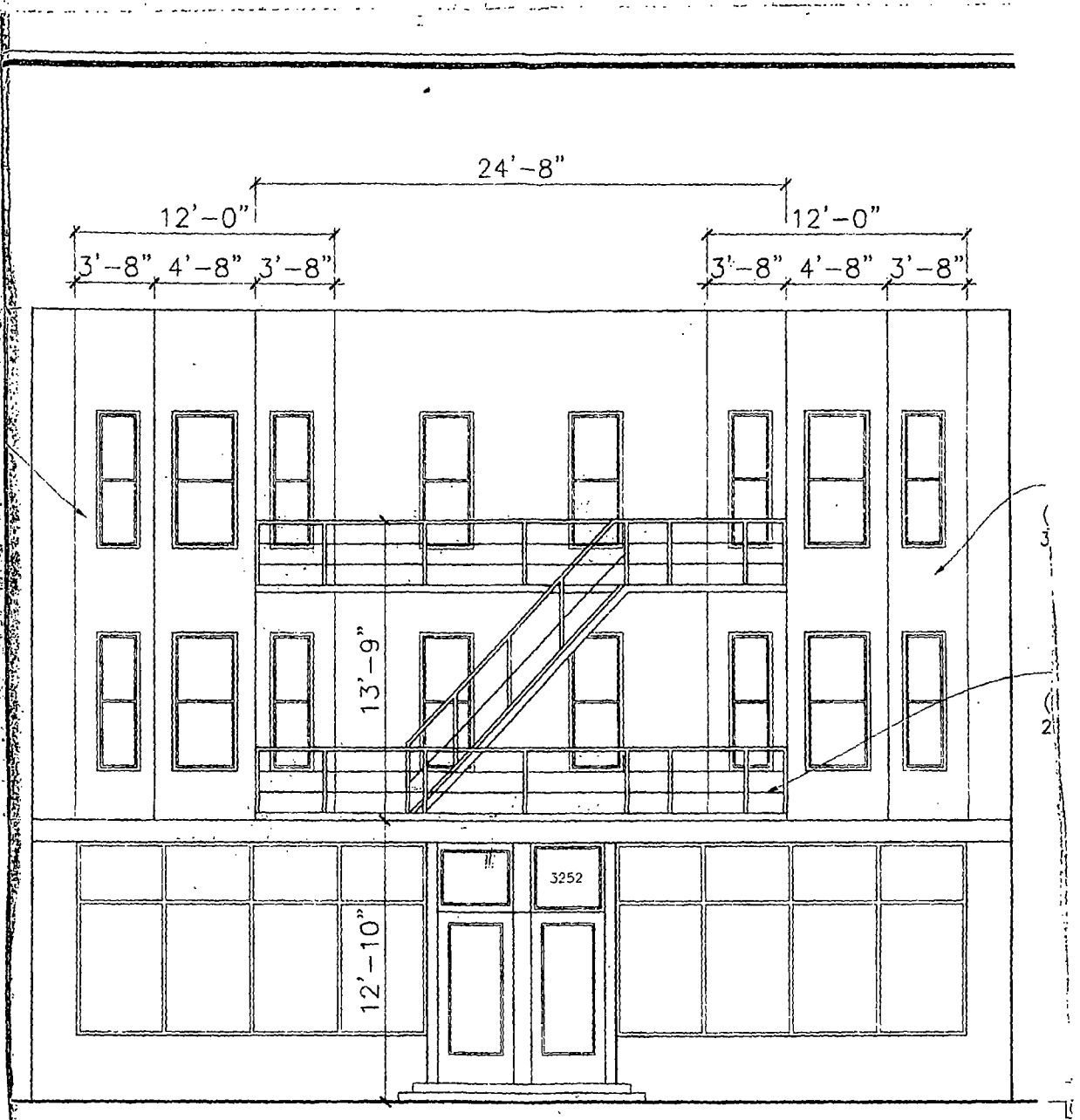

EXISTING
FRONT ELEVATION

SCALE: 3/16"=1'-0"



05/28/2014

Alderman **James A. Balcer**
Ward # **11**
City of Chicago
City Hall, Room **203**
121 North LaSalle Street
Chicago, Illinois 60602

Re: An ordinance to use and maintain a portion of the public right-of-way for **one (1) fire escape(s)** for **DSO PROPERTIES, LLC**, adjacent to the premises known as **3252-54 S. Morgan St.**

Dear Alderman **James A. Balcer**:

The applicant referenced above has requested the use of the public right-of-way for a **fire escape(s)**. An ordinance has been prepared by the Department of Business Affairs and Consumer Protection – Small Business Center - Public Way Use Unit for presentation to the City Council. Because this request was made for properties located in your ward, as approved by you as per the attached, I respectfully request that you introduce the attached ordinance at the next City Council meeting.

If you have any questions regarding this ordinance, please contact Anthony Bertuca at (312) 744-5506.

Department of Business Affairs and Consumer Protection



City of Chicago



O2014-4590

Office of the City Clerk

Document Tracking Sheet

| | |
|---------------------------------|--|
| Meeting Date: | 5/28/2014 |
| Sponsor(s): | Cardenas (12) |
| Type: | Ordinance |
| Title: | Grant(s) of privilege in public way for Jesus Estrella |
| Committee(s) Assignment: | Committee on Transportation and Public Way |

ORDINANCE
JESUS ESTRELLA
Acct. No. 334816 - 1
Permit No. 1112906

Be It Ordained by the City Council of the City of Chicago:

SECTION 1. Permission and authority are hereby given and granted to JESUS ESTRELLA, upon the terms and subject to the conditions of this ordinance to maintain and use, as now constructed, one (1) Stair Case(s) on the public right-of-way adjacent to its premises known as 2259 S. Whipple St..

Said Stair Case(s) at S. Whipple St measure(s):

One (1) at eighteen (18) feet in length, and three point five (3.5) feet in width for a total of sixty-three (63) square feet.

The location of said privilege shall be as shown on prints kept on file with the Department of Business Affairs and Consumer Protection and the Office of the City Clerk.

Said privilege shall be constructed in accordance with plans and specifications approved by the Department of Transportation (Division of Project Development).

This grant of privilege in the public way shall be subject to the provisions of Section 10-28-015 and all other required provisions of the Municipal Code of Chicago.

The grantee shall pay to the City of Chicago as compensation for the privilege #1112906 herein granted the sum of zero (\$.00) per annum in advance.

A 25% penalty will be added for payments received after due date.

The permit holder agrees to hold the City of Chicago harmless for any damage, relocation or replacement costs associated with damage, relocation or removal of private property caused by the City performing work in the public way.

Authority herein given and granted for a period of five (5) years from and after 05/13/2014.

Alderman _____

George Cardenas 12th Ward

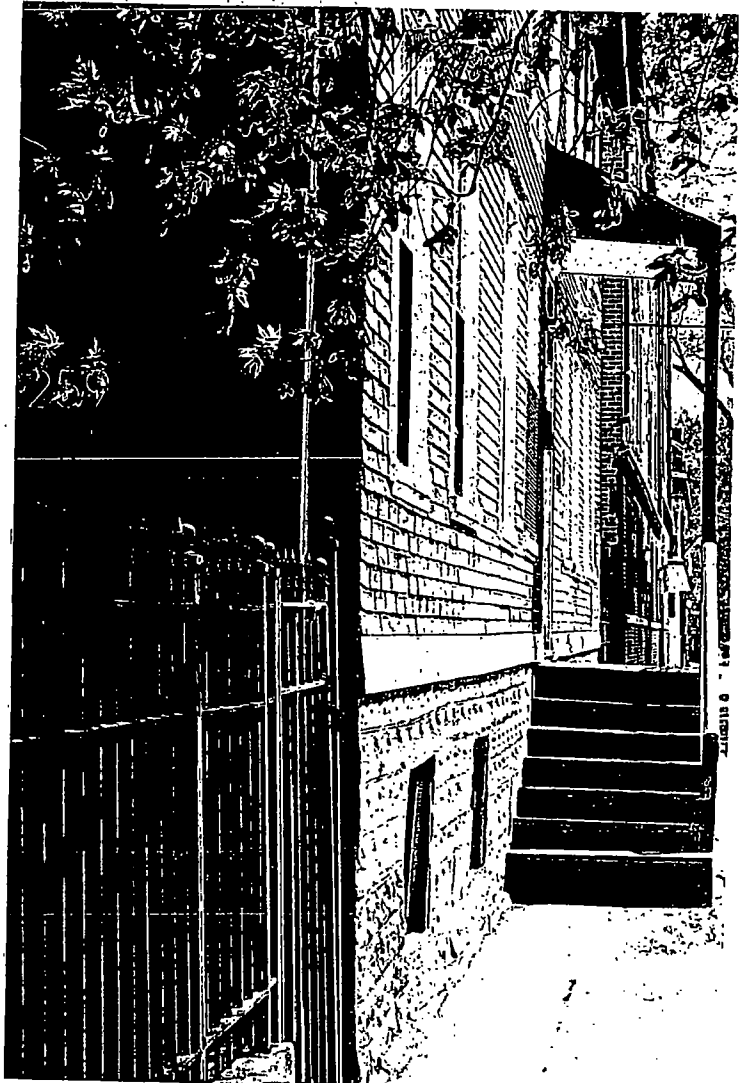



Department of Business Affairs and Consumer Protection
Small Business Center- Public Way Use Unit
City Hall- 121 N. LaSalle Street Room 800 • Chicago, IL 60602
(312)-74-GOBIZ (312-744-6249) • (312) 744-1944 (TTY)
<http://www.cityofchicago.org/bacp>

05/28/2014

Alderman George Cardenas
Ward # 12
City of Chicago
City Hall, Room 203
121 North LaSalle Street
Chicago, Illinois 60602

Re: An ordinance to use and maintain a portion of the public right-of-way for **one (1) stair case(s)** for **JESUS ESTRELLA**, adjacent to the premises known as **2259 S. Whipple St.**

Dear Alderman **George Cardenas**:

The applicant referenced above has requested the use of the public right-of-way for a **stair case(s)**. An ordinance has been prepared by the Department of Business Affairs and Consumer Protection – Small Business Center - Public Way Use Unit for presentation to the City Council. Because this request was made for properties located in your ward, as approved by you as per the attached, I respectfully request that you introduce the attached ordinance at the next City Council meeting.

If you have any questions regarding this ordinance, please contact Anthony Bertuca at (312) 744-5506.

Department of Business Affairs and Consumer Protection



City of Chicago



O2014-4593

Office of the City Clerk

Document Tracking Sheet

| | |
|---------------------------------|---|
| Meeting Date: | 5/28/2014 |
| Sponsor(s): | Quinn (13) |
| Type: | Ordinance |
| Title: | Grant(s) of privilege in public way for American Family Insurance |
| Committee(s) Assignment: | Committee on Transportation and Public Way |

ORDINANCE
AMERICAN FAMILY INSURANCE
Acct. No. 322572 - 1
Permit No. 1113031

Be It Ordained by the City Council of the City of Chicago:

SECTION 1. Permission and authority are hereby given and granted to AMERICAN FAMILY INSURANCE, upon the terms and subject to the conditions of this ordinance to maintain and use one (1) sign(s) projecting over the public right-of-way attached to its premises known as 4403 W. 63rd St..

Said sign structure(s) measures as follows; along W. 63rd St:
One (1) at six (6) feet in length, five (5) feet in height and sixteen (16) feet above grade level.

The location of said privilege shall be as shown on prints kept on file with the Department of Business Affairs and Consumer Protection and the Office of the City Clerk.

Said privilege shall be constructed in accordance with plans and specifications approved by the Department of Transportation (Division of Project Development) and Zoning Department - Signs.

This grant of privilege in the public way shall be subject to the provisions of Section 10-28-015 and all other required provisions of the Municipal Code of Chicago.

The grantee shall pay to the City of Chicago as compensation for the privilege #1113031 herein granted the sum of three hundred (\$300.00) per annum in advance.

A 25% penalty will be added for payments received after due date.

The permit holder agrees to hold the City of Chicago harmless for any damage, relocation or replacement costs associated with damage, relocation or removal of private property caused by the City performing work in the public way.

Authority herein given and granted for a period of five (5) years from and after 05/13/2014.

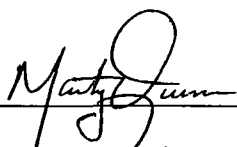
Alderman  _____
Marty Quinn 13th Ward

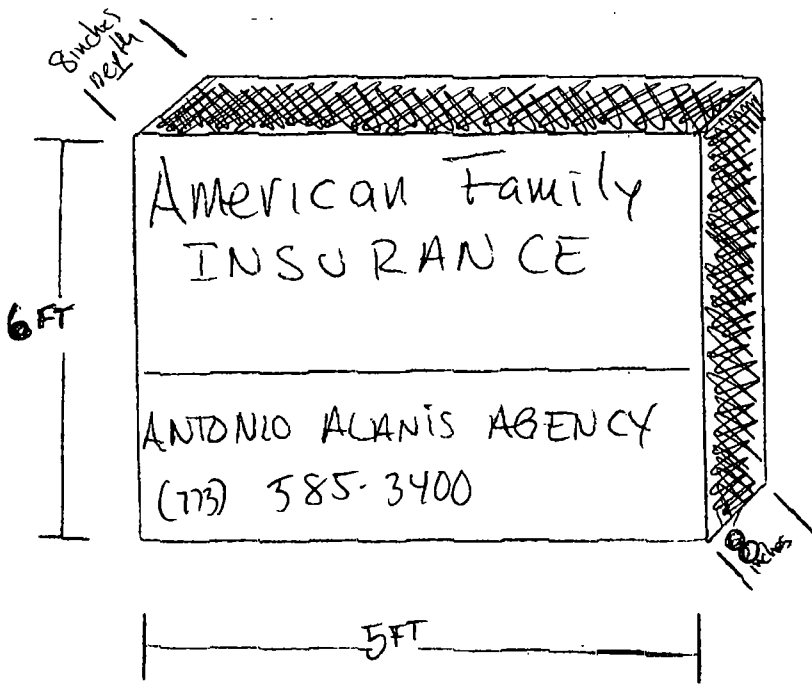

SIGN LOCATED AT
4403 W 63RD ST.
CHICAGO, IL. 60629

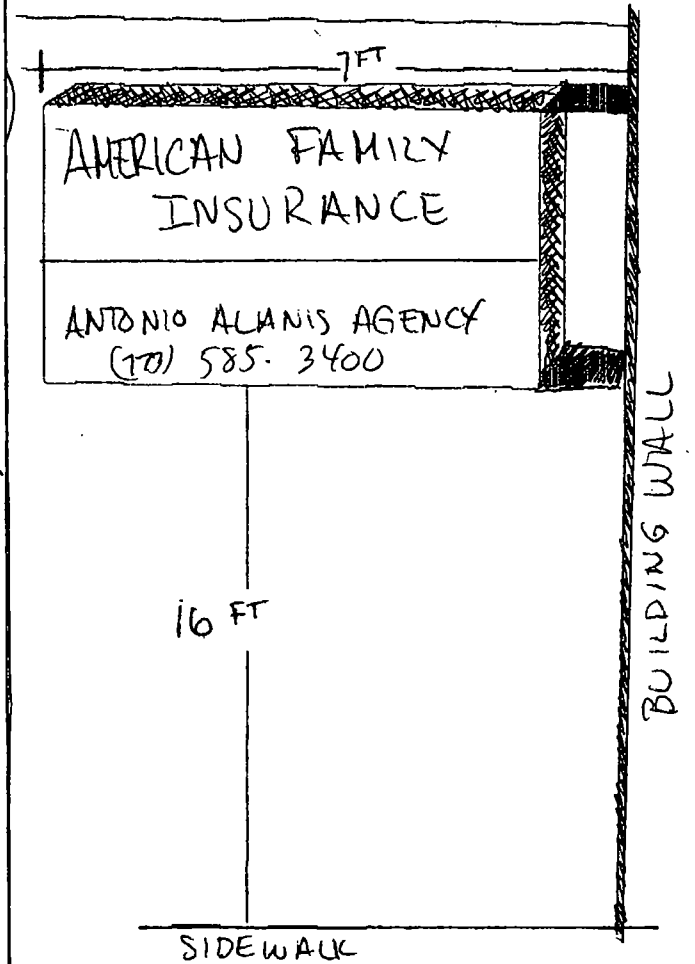



05/28/2014

Alderman **Marty Quinn**
Ward # 13
City of Chicago
City Hall, Room 203
121 North LaSalle Street
Chicago, Illinois 60602

Re: An ordinance to use and maintain a portion of the public right-of-way for **one (1) sign(s)** for **AMERICAN FAMILY INSURANCE**, adjacent to the premises known as **4403 W. 63rd St.**

Dear Alderman **Marty Quinn**:

The applicant referenced above has requested the use of the public right-of-way for a **sign(s)**. An ordinance has been prepared by the Department of Business Affairs and Consumer Protection – Small Business Center - Public Way Use Unit for presentation to the City Council. Because this request was made for properties located in your ward, as approved by you as per the attached, I respectfully request that you introduce the attached ordinance at the next City Council meeting.

If you have any questions regarding this ordinance, please contact Anthony Bertuca at (312) 744-5506.

Department of Business Affairs and Consumer Protection



City of Chicago



O2014-4598

Office of the City Clerk

Document Tracking Sheet

| | |
|---------------------------------|---|
| Meeting Date: | 5/28/2014 |
| Sponsor(s): | Quinn (13) |
| Type: | Ordinance |
| Title: | Grant(s) of privilege in public way for Athletic & Therapeutic Institute of Midway LLC |
| Committee(s) Assignment: | Committee on Transportation and Public Way |

ORDINANCE
ATHLETIC & THERAPEUTIC INSTITUTE OF MIDWAY, LLC
Acct. No. 285488 - 1
Permit No. 1112323

Be It Ordained by the City Council of the City of Chicago:

SECTION 1. Permission and authority are hereby given and granted to ATHLETIC & THERAPEUTIC INSTITUTE OF MIDWAY, LLC, upon the terms and subject to the conditions of this ordinance to maintain and use one (1) sign(s) projecting over the public right-of-way attached to its premises known as 5616 W. 63rd St..

Said sign structure(s) measures as follows; along 63rd Street:
One (1) at twenty-six point five eight (26.58) feet in length, three (3) feet in height and eleven (11) feet above grade level.

The location of said privilege shall be as shown on prints kept on file with the Department of Business Affairs and Consumer Protection and the Office of the City Clerk.

Said privilege shall be constructed in accordance with plans and specifications approved by the Department of Transportation (Division of Project Development) and Zoning Department - Signs.

This grant of privilege in the public way shall be subject to the provisions of Section 10-28-015 and all other required provisions of the Municipal Code of Chicago.

The grantee shall pay to the City of Chicago as compensation for the privilege #1112323 herein granted the sum of three hundred (\$300.00) per annum in advance.

A 25% penalty will be added for payments received after due date.

The permit holder agrees to hold the City of Chicago harmless for any damage, relocation or replacement costs associated with damage, relocation or removal of private property caused by the City performing work in the public way.

Authority herein given and granted for a period of five (5) years from and after Date of Passage.

Alderman _____

Marty Quinn 13th Ward

© Aurora Sign Co. Inc 2014

AURORA SIGN CO.

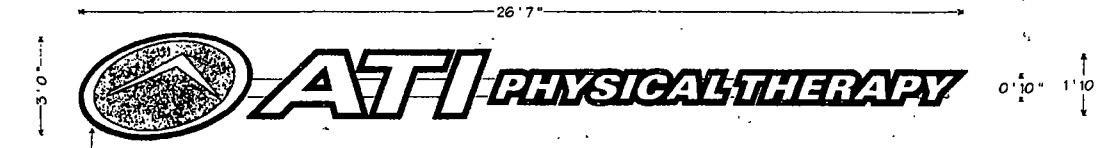

ELECTRICAL DISCONNECT

INDIVIDUAL ILLUMINATED LETTERS WITH BACKER ON RACEWAY

FABRICATE AND INSTALL LETTERS OF ALUMINUM AND ACRYLIC.
 FACES TO BE WHITE ACRYLIC. LOGO TO HAVE COPY APPLIED FIRST SURFACE.
 TRIMCAP TO BE BLACK. RETURNS TO BE BLACK.
 BACKER TO BE BLACK.
 RACEWAY TO BE PAINTED TO MATCH WALL.
 ALL EXPOSED METAL SURFACES TO BE COATED WITH ACRYLIC POLYURETHANE.
 INTERNAL ILLUMINATION TO BE WHITE LEDS.
 SCALE - 3/8" = 1'

SIGN TO BE UL LISTED

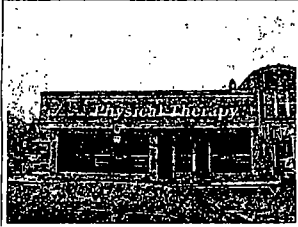
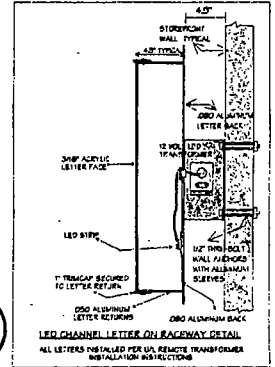

INSTALLATION INSTRUCTIONS

REMOVE EXISTING SIGN AND DISPOSE.
 CENTER NEW SIGN IN SAME AREA.
 CONNECT TO ELECTRICAL SERVICE TO BE PROVIDED BY OTHERS PRIOR TO INSTALL.



| | | | | | | | |
|--|--|-----------------------------------|-------------------------|--------------------|--------------------------------|--------|----------|
| 1100 Route 34 Aurora, Illinois 60504 630 898 5900 office 630 898 6091 fax | Prepared For: ATI PHYSICAL THERAPY | Address: 5616 W 63RD ST | Drawn: 214053 | Sheet: 1 | Design Date: 2/14/14 | Rev 3: | Address: |
| | Location Name: MIDWAY | City/State: CHICAGO, IL | Rev 1: | | | Rev 4: | Color: |
| | | | Rev 2: | | | Rev 5: | Notes: |

NOTE: THIS DRAWING IS THE PROPERTY OF AURORA SIGN CO. IT IS NOT TO BE REPRODUCED, COPIED OR EXHIBITED IN ANY MANNER WITHOUT WRITTEN CONSENT FROM AURORA SIGN CO. CHARGES OF UP TO \$2500.00 WILL BE ASSESSED FOR ANY MIS-USE OF THESE DRAWINGS



05/28/2014

Alderman **Marty Quinn**
Ward # **13**
City of Chicago
City Hall, Room **203**
121 North LaSalle Street
Chicago, Illinois 60602

Re: An ordinance to use and maintain a portion of the public right-of-way for **one (1) sign(s)** for **ATHLETIC & THERAPEUTIC INSTITUTE OF MIDWAY, LLC**, adjacent to the premises known as **5616 W. 63rd St.**

Dear Alderman **Marty Quinn**:

The applicant referenced above has requested the use of the public right-of-way for a **sign(s)**. An ordinance has been prepared by the Department of Business Affairs and Consumer Protection – Small Business Center - Public Way Use Unit for presentation to the City Council. Because this request was made for properties located in your ward, as approved by you as per the attached, I respectfully request that you introduce the attached ordinance at the next City Council meeting.

If you have any questions regarding this ordinance, please contact Anthony Bertuca at (312) 744-5506.

Department of Business Affairs and Consumer Protection



City of Chicago



O2014-4603

Office of the City Clerk

Document Tracking Sheet

| | |
|---------------------------------|---|
| Meeting Date: | 5/28/2014 |
| Sponsor(s): | Quinn (13) |
| Type: | Ordinance |
| Title: | Grant(s) of privilege in public way for Ray Buick, Inc. |
| Committee(s) Assignment: | Committee on Transportation and Public Way |

ORDINANCE
RAY BUICK INC
Acct. No. 2861 - 1
Permit No. 1105331

Be It Ordained by the City Council of the City of Chicago:

SECTION 1. Permission and authority are hereby given and granted to RAY BUICK INC, upon the terms and subject to the conditions of this ordinance to maintain and use two (2) sign(s) projecting over the public right-of-way attached to its premises known as 5011 W. 63rd St..

Said sign structure(s) measures as follows; along 63rd:

One (1) at six point five eight (6.58) feet in length, two point three three (2.33) feet in height and twelve (12) feet above grade level.

One (1) at nine point five (9.5) feet in length, one point four two (1.42) feet in height and fifteen (15) feet above grade level.

The location of said privilege shall be as shown on prints kept on file with the Department of Business Affairs and Consumer Protection and the Office of the City Clerk

Said privilege shall be constructed in accordance with plans and specifications approved by the Department of Transportation (Division of Project Development) and Zoning Department- Signs.

This grant of privilege in the public way shall be subject to the provisions of Section 10-28-015 and all other required provisions of the Municipal Code of Chicago.

The grantee shall pay to the City of Chicago as compensation for the privilege #1105331 herein granted the sum of one hundred seventy-five (\$175.00) per annum in advance.

A 25% penalty will be added for payments received after due date

The permit holder agrees to hold the City of Chicago harmless for any damage, relocation or replacement costs associated with damage, relocation or removal of private property caused by the City performing work in the public way.

Authority herein given and granted for a period of five (5) years from and after Date of Passage.

Alderman _____



Marty Quinn 13th Ward

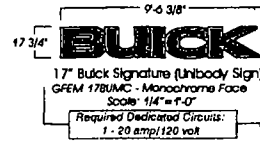
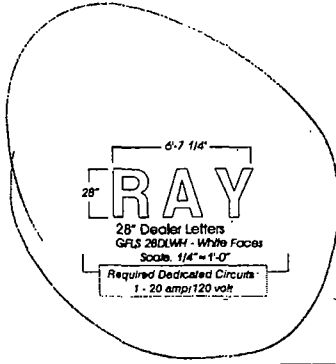

| ELEMENTS | | | | | |
|--|---------------|-----------|-----------|--------|---------------|
| ELEMENT | SIZE (HEIGHT) | LENGTH | SQUARE FT | WEIGHT | ELECTRICAL |
| Buick Signature - Unibody Sign- Monochrome | 17" | 9'-6 3/8" | 14.1 | 1bd | 1 amp |
| Dealer Name Letters | 28" | 6'-7 1/4" | 15.41 | 36 lbs | 5 amps/letter |
| Certified Service Letters - Stocked | 16" (x2) | 7'-1 7/8" | 19.08 | 64 lbs | 1 amp |

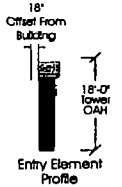
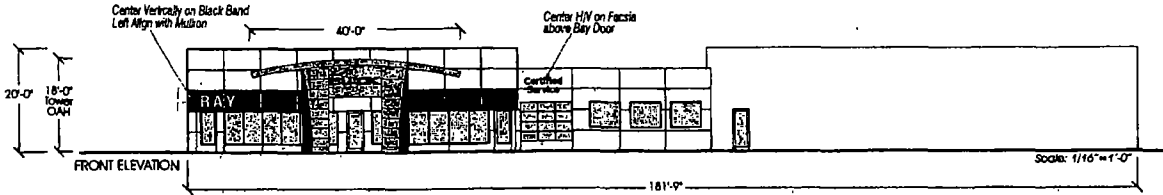

PATTISON SIGN GROUP, INC.
 418 CEDAR BLUFF RD. • SUITE 101 • KNOXVILLE, TN 37923
 • TEL (615) 825-1188 • Fax (615) 894-1182 • Toll Free (888) 216-1876

Customer Approved
Ray Baidy Date: 12.3.12
[Signature] Date: 12.3.12

General Motors working with Pattison Sign Group has developed image standards for all exterior building signage. The size and placement of signs depicted on this rendering of your planned building meet those image standard requirements.

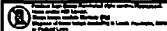
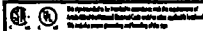

| | |
|-----------------|-------------|
| Project No. | 118514 |
| Client | Ray Buick |
| Location | Chicago, IL |
| Contract No. | 118301 |
| Contractor | UCCO Corp |
| Project Manager | Ray Baidy |
| Project Status | Completed |



05/28/2014

Alderman **Marty Quinn**
Ward # 13
City of Chicago
City Hall, Room 203
121 North LaSalle Street
Chicago, Illinois 60602

Re: An ordinance to use and maintain a portion of the public right-of-way for **two (2) sign(s)** for **RAY BUICK INC**, adjacent to the premises known as **5011 W. 63rd St.**.

Dear Alderman **Marty Quinn**:

The applicant referenced above has requested the use of the public right-of-way for a **sign(s)**. An ordinance has been prepared by the Department of Business Affairs and Consumer Protection– Small Business Center - Public Way Use Unit for presentation to the City Council. Because this request was made for properties located in your ward, as approved by you as per the attached, I respectfully request that you introduce the attached ordinance at the next City Council meeting.

If you have any questions regarding this ordinance, please contact Anthony Bertuca at (312) 744-5506.

Department of Business Affairs and Consumer Protection



City of Chicago



O2014-4616

Office of the City Clerk

Document Tracking Sheet

| | |
|---------------------------------|---|
| Meeting Date: | 5/28/2014 |
| Sponsor(s): | Quinn (13) |
| Type: | Ordinance |
| Title: | Grant(s) of privilege in public way for Taqueria La Haciendita, Inc. |
| Committee(s) Assignment: | Committee on Transportation and Public Way |

ORDINANCE

Taqueria La Haciendita, Inc
Acct. No. 386483 - 1
Permit No. 1110003

Be It Ordained by the City Council of the City of Chicago:

SECTION 1. Permission and authority are hereby given and granted to Taqueria La Haciendita, Inc, upon the terms and subject to the conditions of this ordinance to maintain and use one (1) sign(s) projecting over the public right-of-way attached to its premises known as 5922-24 S. Pulaski Rd..

Said sign structure(s) measures as follows; along S. Pulaski Road:

One (1) at six (6) feet in length, eight (8) feet in height and nine (9) feet above grade level.

The location of said privilege shall be as shown on prints kept on file with the Department of Business Affairs and Consumer Protection and the Office of the City Clerk.

Said privilege shall be constructed in accordance with plans and specifications approved by the Department of Transportation (Division of Project Development) and Zoning Department - Signs.

This grant of privilege in the public way shall be subject to the provisions of Section 10-28-015 and all other required provisions of the Municipal Code of Chicago.

The grantee shall pay to the City of Chicago as compensation for the privilege #1110003 herein granted the sum of three hundred (\$300.00) per annum in advance.

A 25% penalty will be added for payments received after due date.

The permit holder agrees to hold the City of Chicago harmless for any damage, relocation or replacement costs associated with damage, relocation or removal of private property caused by the City performing work in the public way.

Authority herein given and granted for a period of five (5) years from and after Date of Passage.

Alderman _____

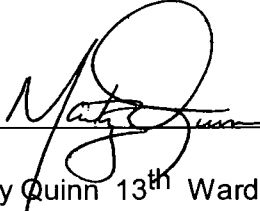
Marty Quinn 13th Ward

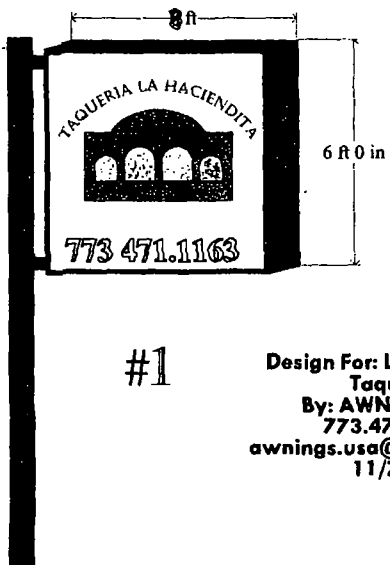
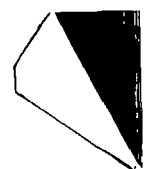

Design For: La Haciendita
 Taqueria
 By: AWNINGS USA
 773.471.1163
 awnings.usa@sbcglobal.net
 11/7/13

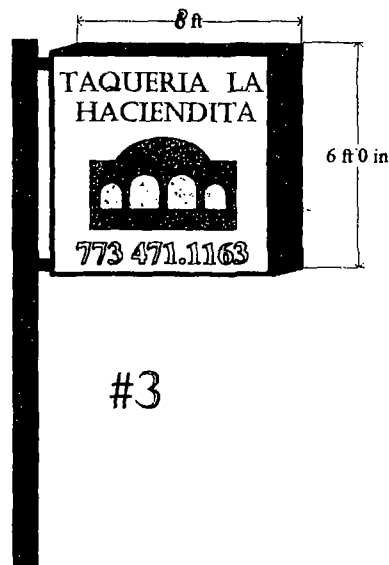
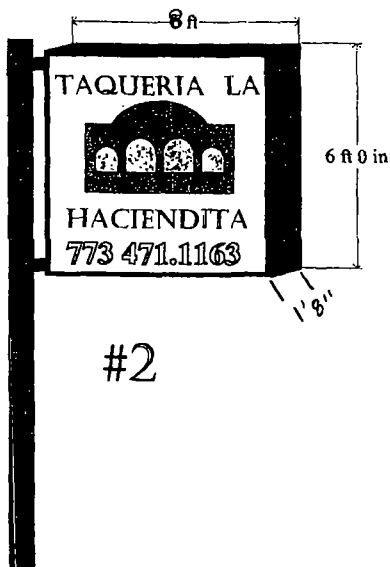



05/28/2014

Alderman **Marty Quinn**
Ward # **13**
City of Chicago
City Hall, Room **203**
121 North LaSalle Street
Chicago, Illinois 60602

Re: An ordinance to use and maintain a portion of the public right-of-way for **one (1) sign(s)** for
Taqueria La Haciendita, Inc, adjacent to the premises known as **5922-24 S. Pulaski Rd.**.

Dear Alderman **Marty Quinn**:

The applicant referenced above has requested the use of the public right-of-way for a **sign(s)**. An ordinance has been prepared by the Department of Business Affairs and Consumer Protection – Small Business Center - Public Way Use Unit for presentation to the City Council. Because this request was made for properties located in your ward, as approved by you as per the attached, I respectfully request that you introduce the attached ordinance at the next City Council meeting.

If you have any questions regarding this ordinance, please contact Anthony Bertuca at (312) 744-5506.

Department of Business Affairs and Consumer Protection



City of Chicago



O2014-4620

Office of the City Clerk

Document Tracking Sheet

| | |
|---------------------------------|--|
| Meeting Date: | 5/28/2014 |
| Sponsor(s): | Burke (14) |
| Type: | Ordinance |
| Title: | Grant(s) of privilege in public way for Apartment Lounge, The |
| Committee(s) Assignment: | Committee on Transportation and Public Way |

ORDINANCE
THE APARTMENT LOUNGE
Acct. No. 117 - 1
Permit No. 1112765

Be It Ordained by the City Council of the City of Chicago:

SECTION 1. Permission and authority are hereby given and granted to THE APARTMENT LOUNGE, upon the terms and subject to the conditions of this ordinance to maintain and use one (1) sign(s) projecting over the public right-of-way attached to its premises known as 3806 W. 47th St..

Said sign structure(s) measures as follows; along W. 47TH ST.:
One (1) at four (4) feet in length, five (5) feet in height and ten (10) feet above grade level.

The location of said privilege shall be as shown on prints kept on file with the Department of Business Affairs and Consumer Protection and the Office of the City Clerk.

Said privilege shall be constructed in accordance with plans and specifications approved by the Department of Transportation (Division of Project Development) and Zoning Department - Signs.

This grant of privilege in the public way shall be subject to the provisions of Section 10-28-015 and all other required provisions of the Municipal Code of Chicago.

The grantee shall pay to the City of Chicago as compensation for the privilege #1112765 herein granted the sum of one hundred (\$100.00) per annum in advance.

A 25% penalty will be added for payments received after due date.

The permit holder agrees to hold the City of Chicago harmless for any damage, relocation or replacement costs associated with damage, relocation or removal of private property caused by the City performing work in the public way.

Authority herein given and granted for a period of five (5) years from and after 04/22/2014.

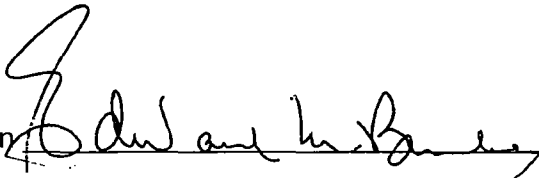
Alderman 

Edward M. Burke 14th Ward

EAST ELEVATION

► Z

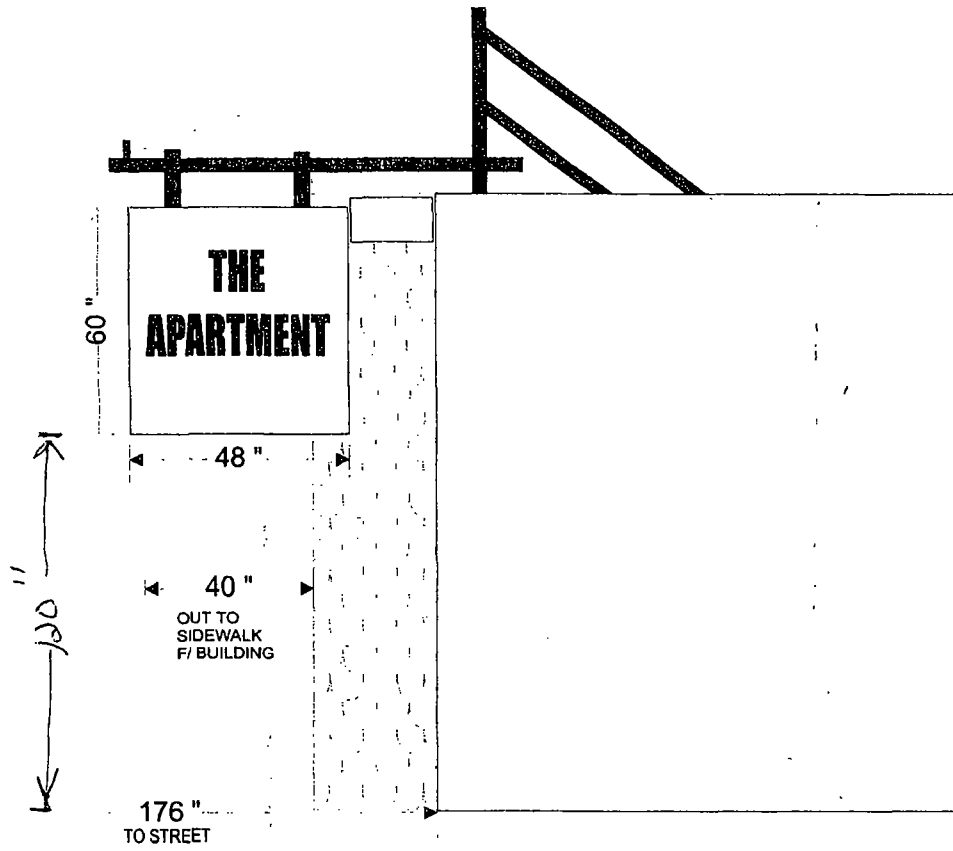



Department of Business Affairs and Consumer Protection
Small Business Center - Public Way Use Unit
City Hall - 121 N. LaSalle Street, Room 800 • Chicago, IL 60602
(312)-74-GOBIZ (312-744-6249) • (312) 744-1944 (TTY)
<http://www.cityofchicago.org/bacp>

05/28/2014

Alderman **Edward M. Burke**
Ward # 14
City of Chicago
City Hall, Room 302
121 North LaSalle Street
Chicago, Illinois 60602

Re: An ordinance to use and maintain a portion of the public right-of-way for **one (1) sign(s)** for **THE APARTMENT LOUNGE**, adjacent to the premises known as **3806 W. 47th St.**

Dear Alderman **Edward M. Burke**:

The applicant referenced above has requested the use of the public right-of-way for a **sign(s)**. An ordinance has been prepared by the Department of Business Affairs and Consumer Protection – Small Business Center - Public Way Use Unit for presentation to the City Council. Because this request was made for properties located in your ward, as approved by you as per the attached, I respectfully request that you introduce the attached ordinance at the next City Council meeting.

If you have any questions regarding this ordinance, please contact Anthony Bertuca at (312) 744-5506.

Department of Business Affairs and Consumer Protection



City of Chicago



O2014-4627

Office of the City Clerk

Document Tracking Sheet

| | |
|---------------------------------|---|
| Meeting Date: | 5/28/2014 |
| Sponsor(s): | Burke (14) |
| Type: | Ordinance |
| Title: | Grant(s) of privilege in public way for PS Orangeco, Inc. No. 28401 |
| Committee(s) Assignment: | Committee on Transportation and Public Way |

ORDINANCE
PS ORANGECO, INC #28401
Acct. No. 16872 - 25
Permit No. 1112822

Be It Ordained by the City Council of the City of Chicago:

SECTION 1. Permission and authority are hereby given and granted to PS ORANGECO, INC #28401, upon the terms and subject to the conditions of this ordinance to maintain and use one (1) sign(s) projecting over the public right-of-way attached to its premises known as 4220 W. 47th St..

Said sign structure(s) measures as follows; along W. 47th Street:

One (1) at ten (10) feet in length, seven (7) feet in height and seventeen (17) feet above grade level.

The location of said privilege shall be as shown on prints kept on file with the Department of Business Affairs and Consumer Protection and the Office of the City Clerk.

Said privilege shall be constructed in accordance with plans and specifications approved by the Department of Transportation (Division of Project Development) and Zoning Department - Signs.

This grant of privilege in the public way shall be subject to the provisions of Section 10-28-015 and all other required provisions of the Municipal Code of Chicago.

The grantee shall pay to the City of Chicago as compensation for the privilege #1112822 herein granted the sum of three hundred (\$300.00) per annum in advance.

A 25% penalty will be added for payments received after due date.

The permit holder agrees to hold the City of Chicago harmless for any damage, relocation or replacement costs associated with damage, relocation or removal of private property caused by the City performing work in the public way.

Authority herein given and granted for a period of five (5) years from and after 01/13/2014.

Alderman _____

Edward M. Burke 14th Ward

E
N + S Sign faces West
W

347 ft

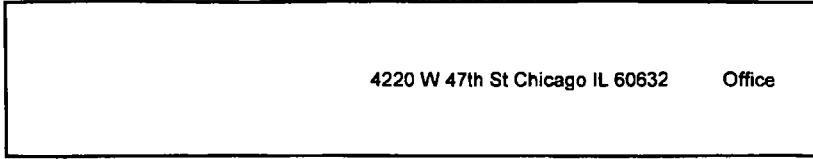

9 ft tall

17 ft

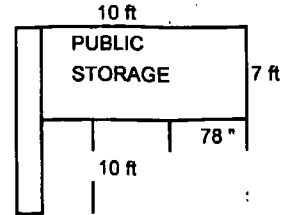

public
Sidewalk



05/28/2014

Alderman Edward M. Burke
Ward # 14
City of Chicago
City Hall, Room 302
121 North LaSalle Street
Chicago, Illinois 60602

Re: An ordinance to use and maintain a portion of the public right-of-way for **one (1) sign(s)** for **PS ORANGECO, INC #28401**, adjacent to the premises known as **4220 W. 47th St.**

Dear Alderman **Edward M. Burke**:

The applicant referenced above has requested the use of the public right-of-way for a **sign(s)**. An ordinance has been prepared by the Department of Business Affairs and Consumer Protection – Small Business Center - Public Way Use Unit for presentation to the City Council. Because this request was made for properties located in your ward, as approved by you as per the attached, I respectfully request that you introduce the attached ordinance at the next City Council meeting.

If you have any questions regarding this ordinance, please contact Anthony Bertuca at (312) 744-5506.

Department of Business Affairs and Consumer Protection



City of Chicago



O2014-4649

Office of the City Clerk Document Tracking Sheet

| | |
|---------------------------------|---|
| Meeting Date: | 5/28/2014 |
| Sponsor(s): | Burke (14) |
| Type: | Ordinance |
| Title: | Grant(s) of privilege in public way for Zapotlan, Inc |
| Committee(s) Assignment: | Committee on Transportation and Public Way |

ORDINANCE
ZAPOTLAN INC
Acct. No. 25858 - 1
Permit No. 1107258

Be It Ordained by the City Council of the City of Chicago:

SECTION 1. Permission and authority are hereby given and granted to ZAPOTLAN INC, upon the terms and subject to the conditions of this ordinance to maintain and use one (1) sign(s) projecting over the public right-of-way attached to its premises known as 3923-25 S. Kedzie Ave..

Said sign structure(s) measures as follows; along South Kedzie Avenue:

One (1) at five point three three (5.33) feet in length, four point two five (4.25) feet in height and twelve (12) feet above grade level.

The location of said privilege shall be as shown on prints kept on file with the Department of Business Affairs and Consumer Protection and the Office of the City Clerk.

Said privilege shall be constructed in accordance with plans and specifications approved by the Department of Transportation (Division of Project Development) and Zoning Department - Signs.

This grant of privilege in the public way shall be subject to the provisions of Section 10-28-015 and all other required provisions of the Municipal Code of Chicago.

The grantee shall pay to the City of Chicago as compensation for the privilege #1107258 herein granted the sum of one hundred (\$100.00) per annum in advance.

A 25% penalty will be added for payments received after due date.

The permit holder agrees to hold the City of Chicago harmless for any damage, relocation or replacement costs associated with damage, relocation or removal of private property caused by the City performing work in the public way.

Authority herein given and granted for a period of five (5) years from and after Date of Passage.

Alderman

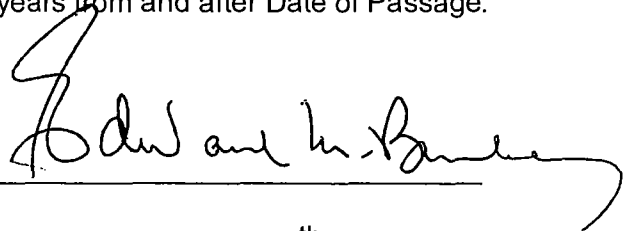

Edward M. Burke 14th Ward



APPLICATION TO USE THE PUBLIC RIGHT OF WAY

EXAMPLE OF SIGN DRAWING

SIGN DRAWING

PROPERTY LOCATION: 3923-25 S. Kedzie

ORGANIZATION(S) NAME: Zapotlan

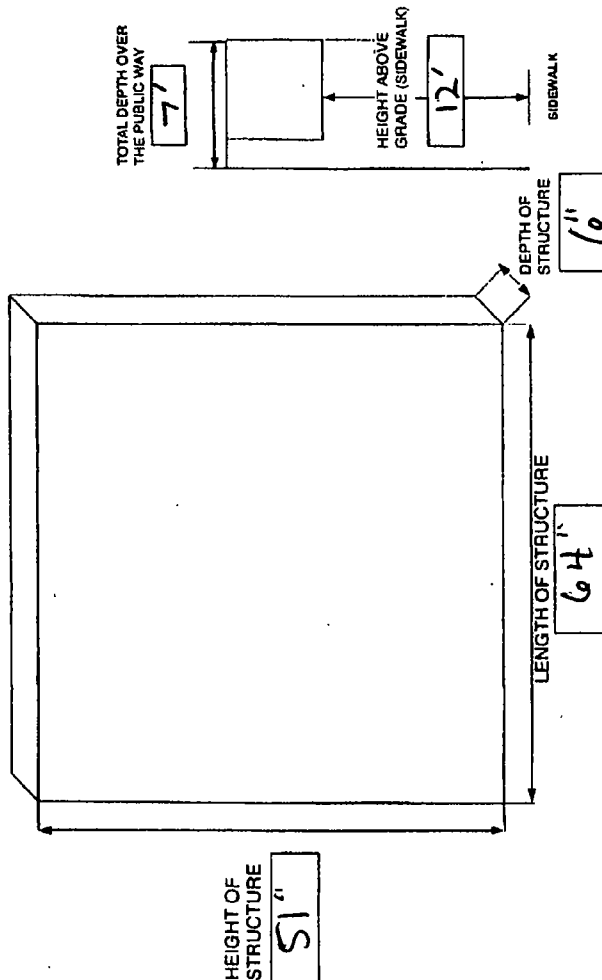



05/28/2014

Alderman **Edward M. Burke**
Ward # 14
City of Chicago
City Hall, Room **302**
121 North LaSalle Street
Chicago, Illinois 60602

Re: An ordinance to use and maintain a portion of the public right-of-way for **one (1) sign(s)** for **ZAPOTLAN INC**, adjacent to the premises known as **3923-25 S. Kedzie Ave.**.

Dear Alderman **Edward M. Burke**:

The applicant referenced above has requested the use of the public right-of-way for a **sign(s)**. An ordinance has been prepared by the Department of Business Affairs and Consumer Protection -- Small Business Center - Public Way Use Unit for presentation to the City Council. Because this request was made for properties located in your ward, as approved by you as per the attached, I respectfully request that you introduce the attached ordinance at the next City Council meeting.

If you have any questions regarding this ordinance, please contact Anthony Bertuca at (312) 744-5506.

Department of Business Affairs and Consumer Protection



City of Chicago



O2014-4725

Office of the City Clerk

Document Tracking Sheet

| | |
|---------------------------------|--|
| Meeting Date: | 5/28/2014 |
| Sponsor(s): | Thompson (16) |
| Type: | Ordinance |
| Title: | Grant(s) of privilege in public way for Mexico Sons Muffler & Brakes |
| Committee(s) Assignment: | Committee on Transportation and Public Way |

ORDINANCE
MEXICO SONS MUFFLER & BRAKES
Acct. No. 341008 - 1
Permit No. 1113185

Be It Ordained by the City Council of the City of Chicago:

SECTION 1. Permission and authority are hereby given and granted to MEXICO SONS MUFFLER & BRAKES, upon the terms and subject to the conditions of this ordinance to maintain and use one (1) sign(s) projecting over the public right-of-way attached to its premises known as 5700 S. Western Ave..

Said sign structure(s) measures as follows; along S WESTERN AVE:
One (1) at fourteen (14) feet in length, seven (7) feet in height and fourteen (14) feet above grade level.

The location of said privilege shall be as shown on prints kept on file with the Department of Business Affairs and Consumer Protection and the Office of the City Clerk.

Said privilege shall be constructed in accordance with plans and specifications approved by the Department of Transportation (Division of Project Development) and Zoning Department- Signs.

This grant of privilege in the public way shall be subject to the provisions of Section 10-28-015 and all other required provisions of the Municipal Code of Chicago.

The grantee shall pay to the City of Chicago as compensation for the privilege #1113185 herein granted the sum of three hundred (\$300.00) per annum in advance.

A 25% penalty will be added for payments received after due date

The permit holder agrees to hold the City of Chicago harmless for any damage, relocation or replacement costs associated with damage, relocation or removal of private property caused by the City performing work in the public way.

Authority herein given and granted for a period of five (5) years from and after 05/13/2014.

Alderman 
Joann Thompson 16th Ward





City of Chicago



O2014-4726

Office of the City Clerk

Document Tracking Sheet

| | |
|---------------------------------|--|
| Meeting Date: | 5/28/2014 |
| Sponsor(s): | Thompson (16) |
| Type: | Ordinance |
| Title: | Grant(s) of privilege in public way for State Farm |
| Committee(s) Assignment: | Committee on Transportation and Public Way |

ORDINANCE
STATE FARM
Acct. No. 326244 - 2
Permit No. 1113111

Be It Ordained by the City Council of the City of Chicago:

SECTION 1. Permission and authority are hereby given and granted to STATE FARM, upon the terms and subject to the conditions of this ordinance to maintain and use one (1) sign(s) projecting over the public right-of-way attached to its premises known as 3045 W. 59th St..

Said sign structure(s) measures as follows; along W 59TH ST:
One (1) at sixty (60) feet in length, five (5) feet in height and ten (10) feet above grade level.

The location of said privilege shall be as shown on prints kept on file with the Department of Business Affairs and Consumer Protection and the Office of the City Clerk.

Said privilege shall be constructed in accordance with plans and specifications approved by the Department of Transportation (Division of Project Development) and Zoning Department - Signs.

This grant of privilege in the public way shall be subject to the provisions of Section 10-28-015 and all other required provisions of the Municipal Code of Chicago.

The grantee shall pay to the City of Chicago as compensation for the privilege #1113111 herein granted the sum of three hundred (\$300.00) per annum in advance.

A 25% penalty will be added for payments received after due date.

The permit holder agrees to hold the City of Chicago harmless for any damage, relocation or replacement costs associated with damage, relocation or removal of private property caused by the City performing work in the public way.

Authority herein given and granted for a period of five (5) years from and after 04/22/2014.

Alderman 
Joann Thompson 16th Ward





City of Chicago



O2014-4728

Office of the City Clerk

Document Tracking Sheet

| | |
|---------------------------------|---|
| Meeting Date: | 5/28/2014 |
| Sponsor(s): | Thompson (16) |
| Type: | Ordinance |
| Title: | Grant(s) of privilege in public way for Tibbs Superior Auto |
| Committee(s) Assignment: | Committee on Transportation and Public Way |

ORDINANCE
TIBBS SUPERIOR AUTO
Acct. No. 52204 - 4
Permit No. 1113104

Be It Ordained by the City Council of the City of Chicago:

SECTION 1. Permission and authority are hereby given and granted to TIBBS SUPERIOR AUTO, upon the terms and subject to the conditions of this ordinance to maintain and use one (1) sign(s) projecting over the public right-of-way attached to its premises known as 6237 S. Ashland Ave..

Said sign structure(s) measures as follows; along S. ASHLAND AVE.:

One (1) at four (4) feet in length, three (3) feet in height and eleven (11) feet above grade level.

The location of said privilege shall be as shown on prints kept on file with the Department of Business Affairs and Consumer Protection and the Office of the City Clerk.

Said privilege shall be constructed in accordance with plans and specifications approved by the Department of Transportation (Division of Project Development) and Zoning Department - Signs.

This grant of privilege in the public way shall be subject to the provisions of Section 10-28-015 and all other required provisions of the Municipal Code of Chicago.

The grantee shall pay to the City of Chicago as compensation for the privilege #1113104 herein granted the sum of one hundred (\$100.00) per annum in advance.

A 25% penalty will be added for payments received after due date.

The permit holder agrees to hold the City of Chicago harmless for any damage, relocation or replacement costs associated with damage, relocation or removal of private property caused by the City performing work in the public way.

Authority herein given and granted for a period of five (5) years from and after 03/14/2012.

Alderman 
Joann Thompson 16th Ward

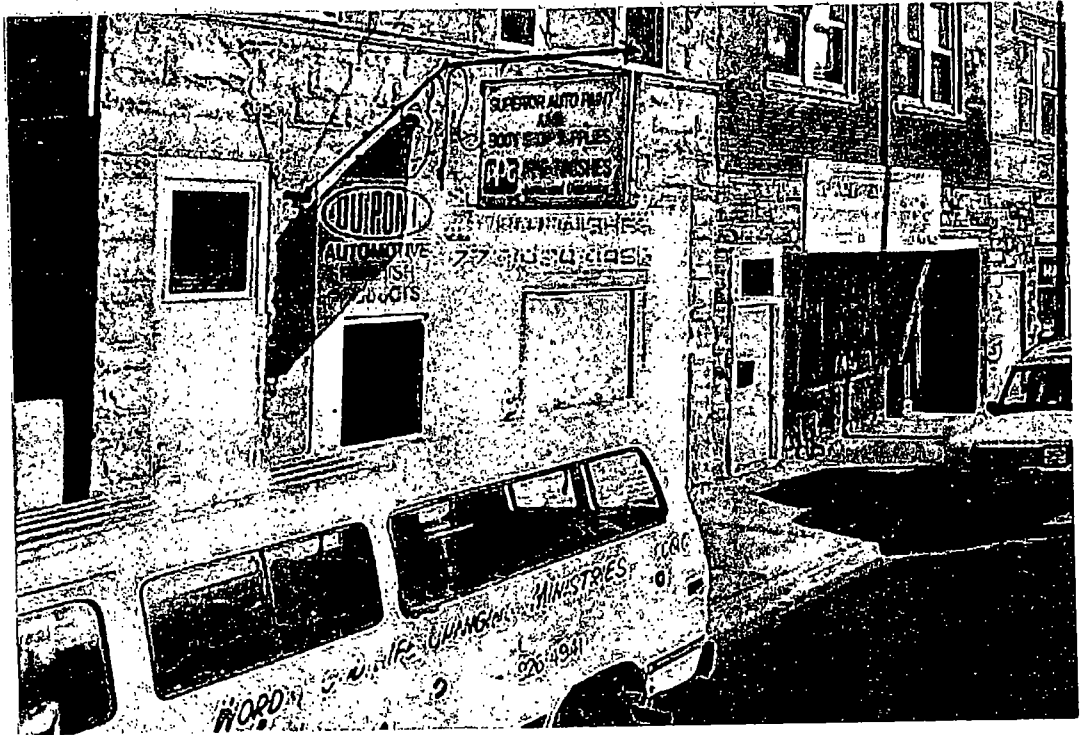
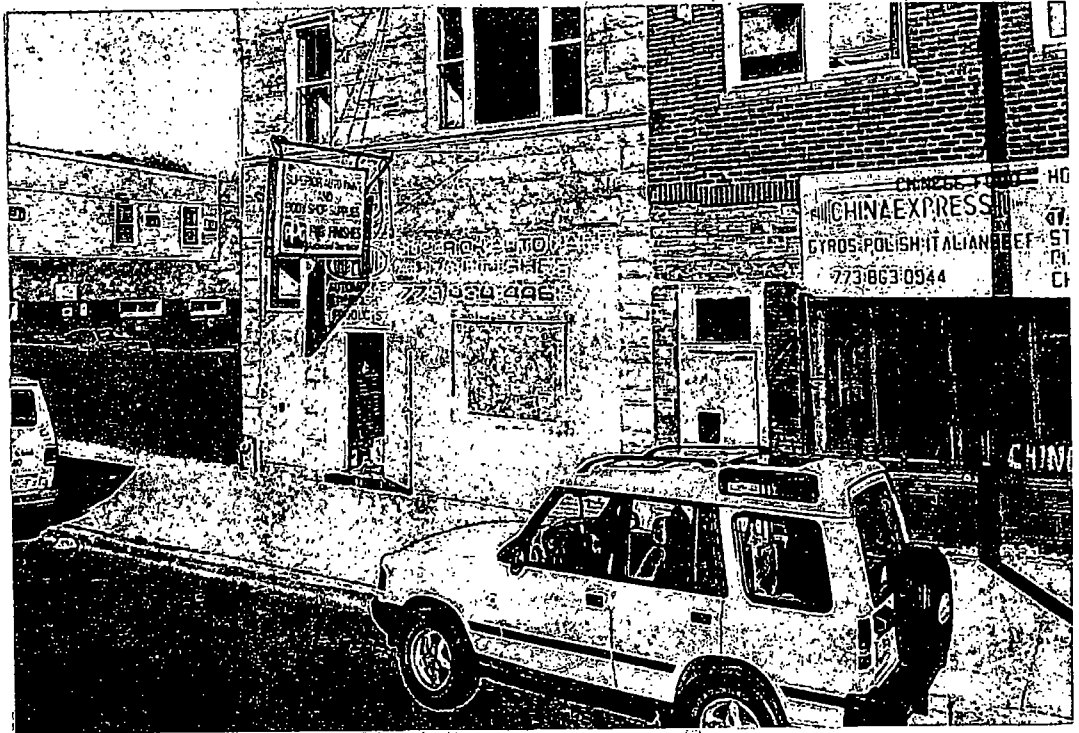



City of Chicago



O2014-4729

Office of the City Clerk

Document Tracking Sheet

| | |
|---------------------------------|---|
| Meeting Date: | 5/28/2014 |
| Sponsor(s): | Thomas (17) |
| Type: | Ordinance |
| Title: | Grant(s) of privilege in public way for Charming Beauty |
| Committee(s) Assignment: | Committee on Transportation and Public Way |

ORDINANCE
CHARMING BEAUTY
Acct. No. 316100 - 1
Permit No. 1110293

Be It Ordained by the City Council of the City of Chicago:

SECTION 1. Permission and authority are hereby given and granted to CHARMING BEAUTY, upon the terms and subject to the conditions of this ordinance to maintain and use one (1) sign(s) projecting over the public right-of-way attached to its premises known as 1021 W. 79th St..

Said sign structure(s) measures as follows; along W. 79th Street:
One (1) at nine (9) feet in length, six (6) feet in height and sixteen (16) feet above grade level.

The location of said privilege shall be as shown on prints kept on file with the Department of Business Affairs and Consumer Protection and the Office of the City Clerk.

Said privilege shall be constructed in accordance with plans and specifications approved by the Department of Transportation (Division of Project Development) and Zoning Department - Signs.

This grant of privilege in the public way shall be subject to the provisions of Section 10-28-015 and all other required provisions of the Municipal Code of Chicago.

The grantee shall pay to the City of Chicago as compensation for the privilege #1110293 herein granted the sum of three hundred (\$300.00) per annum in advance.

A 25% penalty will be added for payments received after due date.

The permit holder agrees to hold the City of Chicago harmless for any damage, relocation or replacement costs associated with damage, relocation or removal of private property caused by the City performing work in the public way.

Authority herein given and granted for a period of five (5) years from and after 11/05/2013.

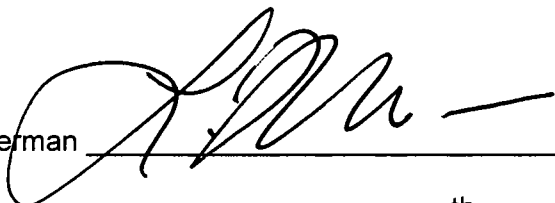
Alderman 
Latasha R. Thomas 17th Ward

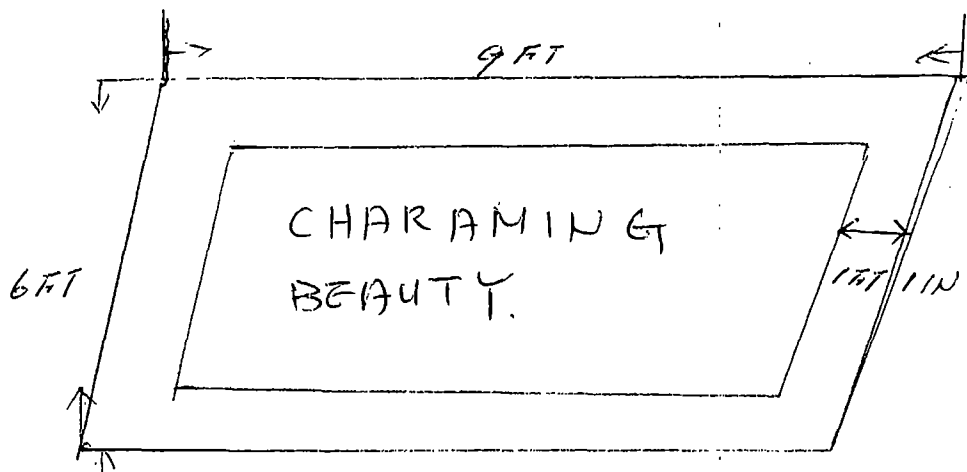

16 FT. 1021 W. 79TH ST
CHICAGO. IL 60620



City of Chicago



O2014-4730

Office of the City Clerk

Document Tracking Sheet

| | |
|---------------------------------|---|
| Meeting Date: | 5/28/2014 |
| Sponsor(s): | Thomas (17) |
| Type: | Ordinance |
| Title: | Grant(s) of privilege in public way for City Mart |
| Committee(s) Assignment: | Committee on Transportation and Public Way |

ORDINANCE
CITY MART
Acct. No. 230366 - 1
Permit No. 1110180

Be It Ordained by the City Council of the City of Chicago:

SECTION 1. Permission and authority are hereby given and granted to CITY MART, upon the terms and subject to the conditions of this ordinance to maintain and use one (1) sign(s) projecting over the public right-of-way attached to its premises known as 750 W. 79th St..

Said sign structure(s) measures as follows; along W 79TH ST:
One (1) at six (6) feet in length, five (5) feet in height and sixteen (16) feet above grade level.

The location of said privilege shall be as shown on prints kept on file with the Department of Business Affairs and Consumer Protection and the Office of the City Clerk.

Said privilege shall be constructed in accordance with plans and specifications approved by the Department of Transportation (Division of Project Development) and Zoning Department - Signs.

This grant of privilege in the public way shall be subject to the provisions of Section 10-28-015 and all other required provisions of the Municipal Code of Chicago.

The grantee shall pay to the City of Chicago as compensation for the privilege #1110180 herein granted the sum of three hundred (\$300.00) per annum in advance.

A 25% penalty will be added for payments received after due date.

The permit holder agrees to hold the City of Chicago harmless for any damage, relocation or replacement costs associated with damage, relocation or removal of private property caused by the City performing work in the public way.

Authority herein given and granted for a period of five (5) years from and after 11/05/2013.

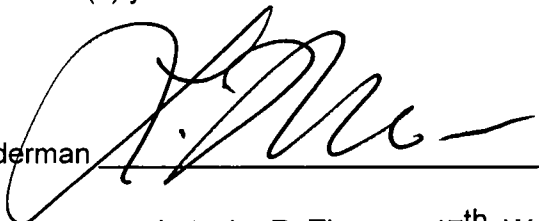
Alderman 
Latasha R. Thomas 17th Ward

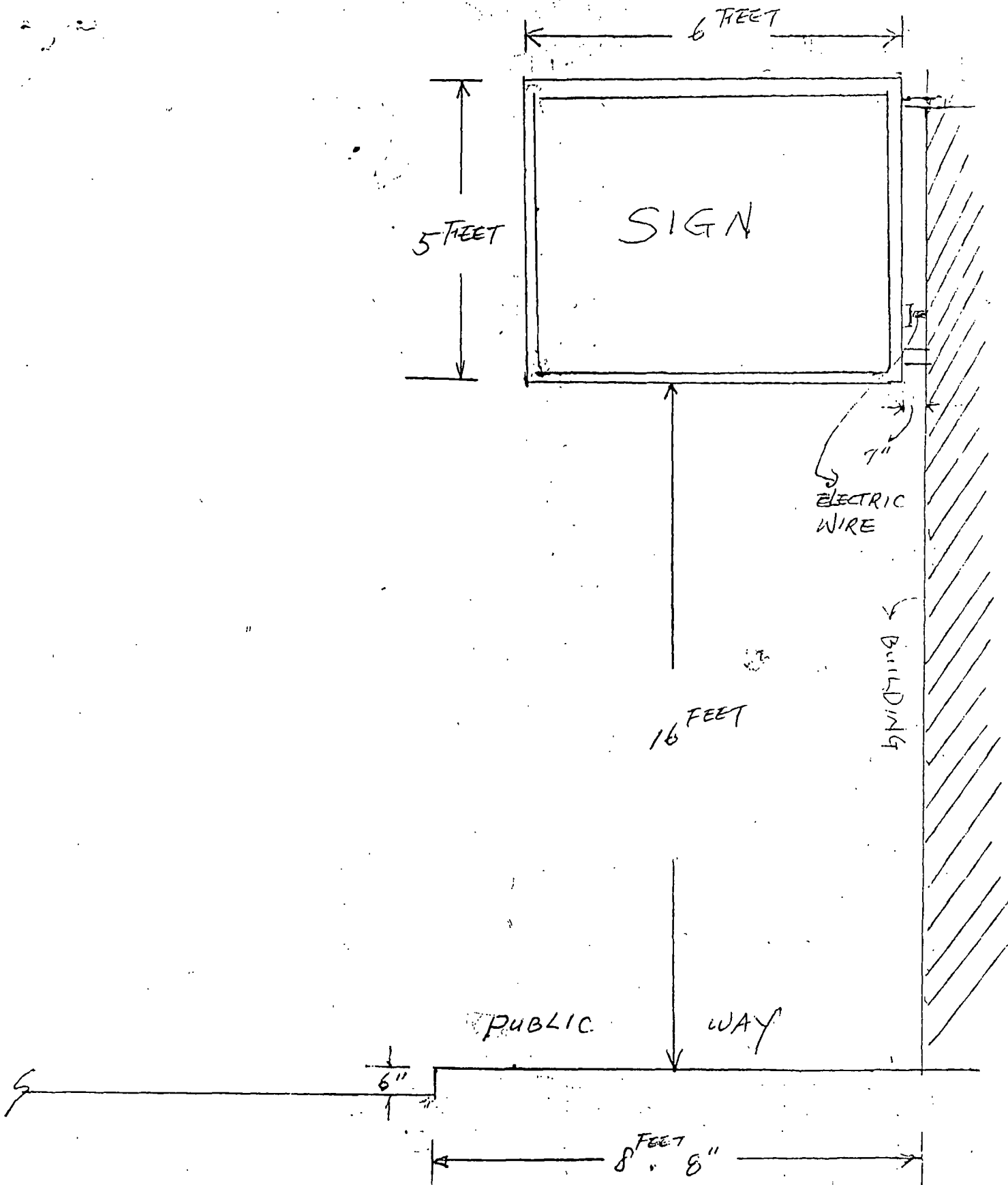

750 W 79TH ST CHICAGO IL 60620
 CITY MART SIGN



City of Chicago



O2014-4732

Office of the City Clerk

Document Tracking Sheet

| | |
|---------------------------------|--|
| Meeting Date: | 5/28/2014 |
| Sponsor(s): | Thomas (17) |
| Type: | Ordinance |
| Title: | Grant(s) of privilege in public way for King Food & Liquor |
| Committee(s) Assignment: | Committee on Transportation and Public Way |

ORDINANCE
KING FOOD & LIQUOR
Acct. No. 264251 - 1
Permit No. 1106514

Be It Ordained by the City Council of the City of Chicago:

SECTION 1. Permission and authority are hereby given and granted to KING FOOD & LIQUOR, upon the terms and subject to the conditions of this ordinance to maintain and use one (1) sign(s) projecting over the public right-of-way attached to its premises known as 6759 S. Western Ave..

Said sign structure(s) measures as follows; along S. Western Avenue:
One (1) at ten (10) feet in length, four (4) feet in height and ten (10) feet above grade level.

The location of said privilege shall be as shown on prints kept on file with the Department of Business Affairs and Consumer Protection and the Office of the City Clerk.

Said privilege shall be constructed in accordance with plans and specifications approved by the Department of Transportation (Division of Project Development) and Zoning Department - Signs.

This grant of privilege in the public way shall be subject to the provisions of Section 10-28-015 and all other required provisions of the Municipal Code of Chicago.

The grantee shall pay to the City of Chicago as compensation for the privilege #1106514 herein granted the sum of three hundred (\$300.00) per annum in advance.

A 25% penalty will be added for payments received after due date.

The permit holder agrees to hold the City of Chicago harmless for any damage, relocation or replacement costs associated with damage, relocation or removal of private property caused by the City performing work in the public way.

Authority herein given and granted for a period of five (5) years from and after 05/14/2013.

Alderman _____

Latasha R. Thomas 17th Ward

APPROVED
X



10" TEXT
5' TEXT

4'x10' PROJECTING SIGN ON TWO STORY BUILDING

- 2" X 2" X 3/16" GALV. ANGLE IRON FRAME / WELDED
- 1 1/2" X 3/8" GALV. BOLTS
- 20 GAUGE GALV. DRUM
- 2" X 2" GALV. 20 GA. TRIM
- 1/2" DRAIN HOLES
- 3/16" LEXAN FACES
- ALL WIRING IN 20 GA. RACEWAYS
- NO. 14 WIRE, 300V. 15 AMP
- HIGH OUTPUT LAMPS
- 1,000 V. LAMP HOLDERS
- DISCONNECT SWITCH
- 800 M.A. BALLASTS 110 V.
- U.L. APPROVED

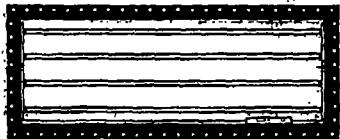

21 TO 40 SQ. FT. PROJECTING SIGN
(TYPICAL)

| BEST NEON SIGN CO. | |
|---------------------------------|----------------|
| SCALE: 1/2" = 1'-0" | BY: KING |
| CUSTOMER: KING FOOD & LIQUOR | |
| JOB ADDRESS: 6759 S. WESTERN | |
| CITY: CHICAGO | STATE: IL |
| ARTIST: CR | SALES: 3/27/04 |
| SALES APPROVED: | DATE: |
| CUSTOMER APPROVAL: shed. n. not | |

By signing the approval box on this sketch, I understand that I am accepting all aspects of this drawing. This includes artwork, specifications, dimensions, scale and any other representations herein. I also understand that color representations on this sketch are approximate, and may differ from manufactured product exactly.



City of Chicago



O2014-4735

Office of the City Clerk

Document Tracking Sheet

| | |
|---------------------------------|---|
| Meeting Date: | 5/28/2014 |
| Sponsor(s): | Thomas (17) |
| Type: | Ordinance |
| Title: | Grant(s) of privilege in public way for Riverdale Body Shop |
| Committee(s) Assignment: | Committee on Transportation and Public Way |

ORDINANCE
RIVERDALE BODY SHOP
Acct. No. 337863 - 1
Permit No. 1108505

Be It Ordained by the City Council of the City of Chicago:

SECTION 1. Permission and authority are hereby given and granted to RIVERDALE BODY SHOP, upon the terms and subject to the conditions of this ordinance to maintain and use one (1) sign(s) projecting over the public right-of-way attached to its premises known as 7917 S. Vincennes Ave..

Said sign structure(s) measures as follows; along S. Vincennes Avenue:
One (1) at six (6) feet in length, four (4) feet in height and ten (10) feet above grade level.

The location of said privilege shall be as shown on prints kept on file with the Department of Business Affairs and Consumer Protection and the Office of the City Clerk.

Said privilege shall be constructed in accordance with plans and specifications approved by the Department of Transportation (Division of Project Development) and Zoning Department - Signs.

This grant of privilege in the public way shall be subject to the provisions of Section 10-28-015 and all other required provisions of the Municipal Code of Chicago.

The grantee shall pay to the City of Chicago as compensation for the privilege #1108505 herein granted the sum of one hundred (\$100.00) per annum in advance.

A 25% penalty will be added for payments received after due date.

The permit holder agrees to hold the City of Chicago harmless for any damage, relocation or replacement costs associated with damage, relocation or removal of private property caused by the City performing work in the public way.

Authority herein given and granted for a period of five (5) years from and after Date of Passage.

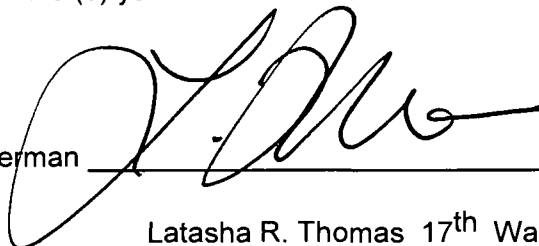
Alderman  _____
Latasha R. Thomas 17th Ward

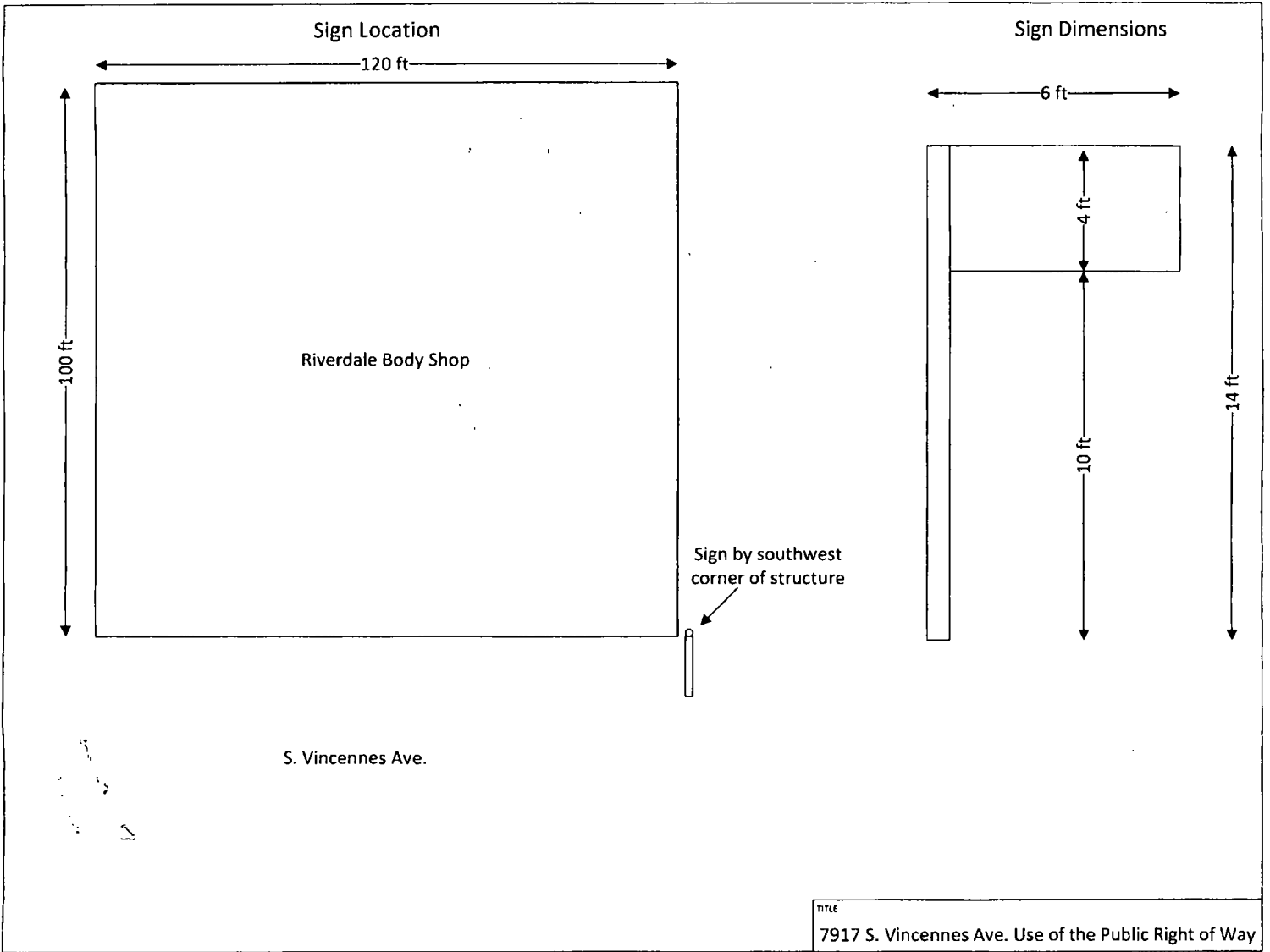



City of Chicago



O2014-4736

Office of the City Clerk
Document Tracking Sheet

| | |
|---------------------------------|---|
| Meeting Date: | 5/28/2014 |
| Sponsor(s): | O'Shea (19) |
| Type: | Ordinance |
| Title: | Grant(s) of privilege in public way for Taqueria Valparaiso |
| Committee(s) Assignment: | Committee on Transportation and Public Way |

ORDINANCE
TAQUERIA VALPARAISO
Acct. No. 283673 - 1
Permit No. 1113070

Be It Ordained by the City Council of the City of Chicago:

SECTION 1. Permission and authority are hereby given and granted to TAQUERIA VALPARAISO, upon the terms and subject to the conditions of this ordinance to maintain and use one (1) sign(s) projecting over the public right-of-way attached to its premises known as 10500 S. Western Ave..

Said sign structure(s) measures as follows; along S WESTERN AVE:

One (1) at six (6) feet in length, seven (7) feet in height and twelve (12) feet above grade level.

The location of said privilege shall be as shown on prints kept on file with the Department of Business Affairs and Consumer Protection and the Office of the City Clerk.

Said privilege shall be constructed in accordance with plans and specifications approved by the Department of Transportation (Division of Project Development) and Zoning Department - Signs.

This grant of privilege in the public way shall be subject to the provisions of Section 10-28-015 and all other required provisions of the Municipal Code of Chicago.

The grantee shall pay to the City of Chicago as compensation for the privilege #1113070 herein granted the sum of three hundred (\$300.00) per annum in advance.

A 25% penalty will be added for payments received after due date.

The permit holder agrees to hold the City of Chicago harmless for any damage, relocation or replacement costs associated with damage, relocation or removal of private property caused by the City performing work in the public way.

Authority herein given and granted for a period of five (5) years from and after 04/22/2014.

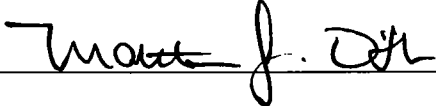
Alderman 
Matthew J. O'Shea 19th Ward

10500 S. Western Ave., Chicago

Taqueria Valparaiso Inc.

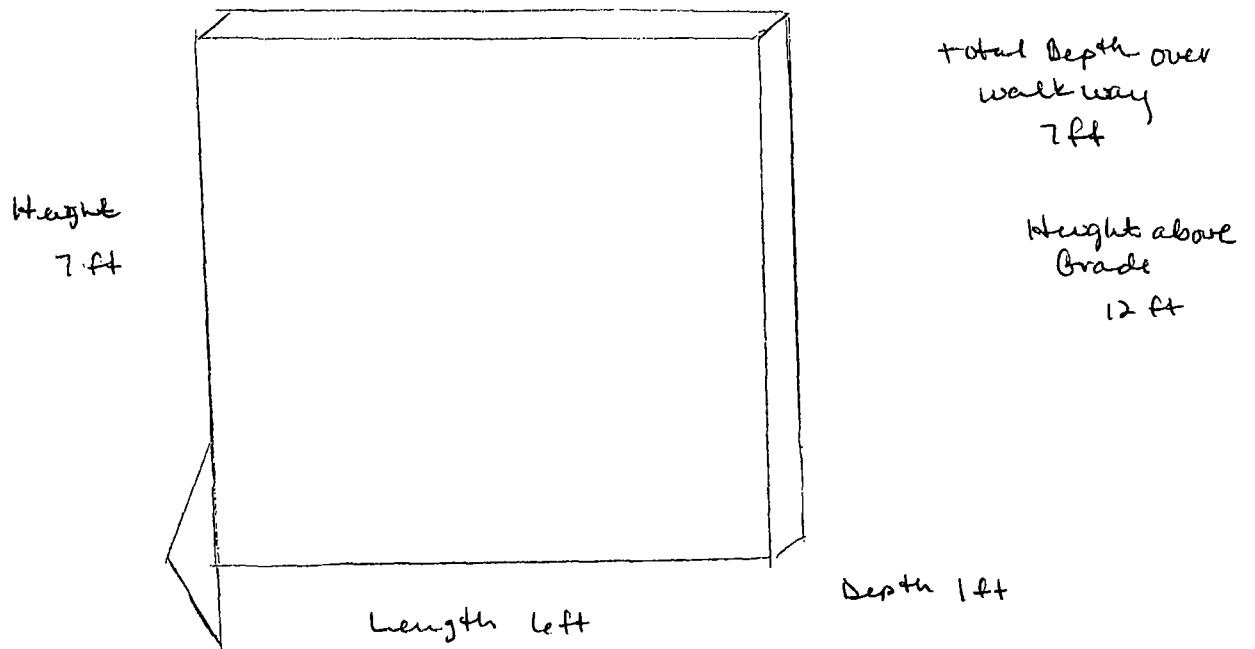



05/28/2014

Alderman **Matthew J. O'Shea**
Ward # **19**
City of Chicago
City Hall, Room **300**
121 North LaSalle Street
Chicago, Illinois 60602

Re: An ordinance to use and maintain a portion of the public right-of-way for **one (1) sign(s)** for
TAQUERIA VALPARAISO, adjacent to the premises known as **10500 S. Western Ave.**.

Dear Alderman **Matthew J. O'Shea**:

The applicant referenced above has requested the use of the public right-of-way for a **sign(s)**. An ordinance has been prepared by the Department of Business Affairs and Consumer Protection – Small Business Center - Public Way Use Unit for presentation to the City Council. Because this request was made for properties located in your ward, as approved by you as per the attached, I respectfully request that you introduce the attached ordinance at the next City Council meeting.

If you have any questions regarding this ordinance, please contact Anthony Bertuca at (312) 744-5506.

Department of Business Affairs and Consumer Protection



City of Chicago



O2014-4741

Office of the City Clerk

Document Tracking Sheet

| | |
|---------------------------------|--|
| Meeting Date: | 5/28/2014 |
| Sponsor(s): | Cochran (20) |
| Type: | Ordinance |
| Title: | Grant(s) of privilege in public way for Cosmo Superstore, Inc. |
| Committee(s) Assignment: | Committee on Transportation and Public Way |

ORDINANCE
COSMO SUPERSTORE INC
Acct. No. 253708 - 1
Permit No. 1113068

Be It Ordained by the City Council of the City of Chicago:

SECTION 1. Permission and authority are hereby given and granted to COSMO SUPERSTORE INC, upon the terms and subject to the conditions of this ordinance to maintain and use, as now constructed, one (1) Fence on the public right-of-way adjacent to its premises known as 6250 S. Cottage Grove Ave..

Said Fence at S Cottage Grove Ave measure(s):

One (1) at one hundred fourteen (114) feet in length, and point one seven (.17) feet in width for a total of nineteen point three eight (19.38) square feet. Existing fence is approximately six (6) feet in height.

The location of said privilege shall be as shown on prints kept on file with the Department of Business Affairs and Consumer Protection and the Office of the City Clerk.

Said privilege shall be constructed in accordance with plans and specifications approved by the Department of Transportation (Division of Project Development).

This grant of privilege in the public way shall be subject to the provisions of Section 10-28-015 and all other required provisions of the Municipal Code of Chicago.

The grantee shall pay to the City of Chicago as compensation for the privilege #1113068 herein granted the sum of four hundred (\$400.00) per annum in advance.

A 25% penalty will be added for payments received after due date.

The permit holder agrees to hold the City of Chicago harmless for any damage, relocation or replacement costs associated with damage, relocation or removal of private property caused by the City performing work in the public way.

Authority herein given and granted for a period of five (5) years from and after 01/13/2014.

Alderman

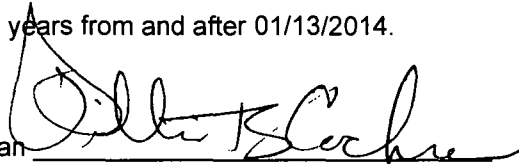

Willie Cochran 20th Ward





Department of Business Affairs and Consumer Protection
Small Business Center- Public Way Use Unit
City Hall - 121 N. LaSalle Street Room 800 • Chicago, IL 60602
(312)-74-GOBIZ (312-744-6249) • (312) 744-1944 (TTY)
<http://www.cityofchicago.org/bacp>

05/28/2014

Alderman Willie Cochran
Ward # 20
City of Chicago
City Hall, Room 300
121 North LaSalle Street
Chicago, Illinois 60602

Re: An ordinance to use and maintain a portion of the public right-of-way for **one (1) fence(s)** for
COSMO SUPERSTORE INC, adjacent to the premises known as **6250 S. Cottage Grove Ave.**

Dear Alderman **Willie Cochran**:

The applicant referenced above has requested the use of the public right-of-way for a **fence(s)**. An ordinance has been prepared by the Department of Business Affairs and Consumer Protection – Small Business Center - Public Way Use Unit for presentation to the City Council. Because this request was made for properties located in your ward, as approved by you as per the attached, I respectfully request that you introduce the attached ordinance at the next City Council meeting.

If you have any questions regarding this ordinance, please contact Anthony Bertuca at (312) 744-5506.

Department of Business Affairs and Consumer Protection



City of Chicago



O2014-4743

Office of the City Clerk

Document Tracking Sheet

| | |
|---------------------------------|--|
| Meeting Date: | 5/28/2014 |
| Sponsor(s): | Cochran (20) |
| Type: | Ordinance |
| Title: | Grant(s) of privilege in public way for Dolex Dollar Express, Inc. |
| Committee(s) Assignment: | Committee on Transportation and Public Way |

ORDINANCE
DOLEX DOLLAR EXPRESS, INC.
Acct. No. 67116 - 72
Permit No. 1112934

Be It Ordained by the City Council of the City of Chicago:

SECTION 1. Permission and authority are hereby given and granted to DOLEX DOLLAR EXPRESS, INC., upon the terms and subject to the conditions of this ordinance to maintain and use one (1) sign(s) projecting over the public right-of-way attached to its premises known as 1838 W. 47th St..

Said sign structure(s) measures as follows; along W 47TH ST:
One (1) at twelve (12) feet in length, three (3) feet in height and ten (10) feet above grade level.

The location of said privilege shall be as shown on prints kept on file with the Department of Business Affairs and Consumer Protection and the Office of the City Clerk.

Said privilege shall be constructed in accordance with plans and specifications approved by the Department of Transportation (Division of Project Development) and Zoning Department - Signs.

This grant of privilege in the public way shall be subject to the provisions of Section 10-28-015 and all other required provisions of the Municipal Code of Chicago.

The grantee shall pay to the City of Chicago as compensation for the privilege #1112934 herein granted the sum of three hundred (\$300.00) per annum in advance.

A 25% penalty will be added for payments received after due date.

The permit holder agrees to hold the City of Chicago harmless for any damage, relocation or replacement costs associated with damage, relocation or removal of private property caused by the City performing work in the public way.

Authority herein given and granted for a period of five (5) years from and after 05/13/2014.

Alderman 

Willie Cochran 20th Ward



SIGN IS MOUNTED 120" ABOVE GRADE TO THE BOTTOM OF SIGN
 AND EXTENDS 10" OVER PUBLIC WAY
 10'-2" FROM OUTER EDGE OF SIGN TO CURB LINE

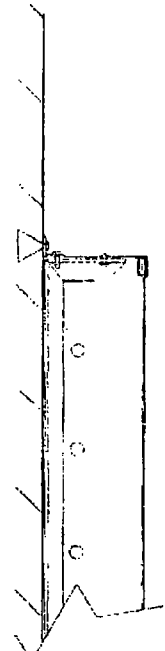
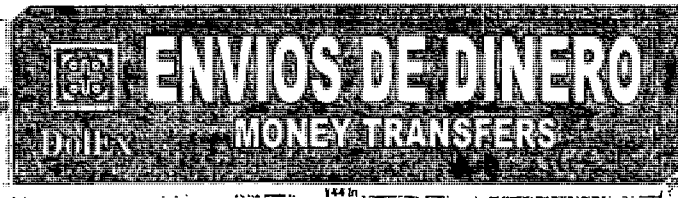

- EXISTING WALL
- CLIP ON 5'-0" CENTERS
TOP AND BOTTOM
- 1/2" DIA. STL. EXPANSION BOLT
WITH 4" MINIMUM EMBEDMENT
OR ANCHOR TO SUIT WALL CONDITIONS
.083 ALUMINUM
- .083 ALUMINUM RETAINER
- 3/8" BOLT DRUM FASTENER ON 18" CENTERS
- 2" X 2" X 1/4" GALV. STL. ANGLE
HORIZONTAL CONTINUOUS FRAMING
TOP AND BOTTOM
- 2" X 2" X 1/4" GALV. STL. ANGLE
VERTICAL FRAMING ON 5'-0" CENTERS MAX.
- TYPICAL H.O. LAMP
- 3/16" ACRYLIC FACE

These drawings are the exclusive property of Integrity Sign Company. Any use other than that intended is not allowed without the express written consent of Integrity Sign Company. Ideas contained herein are confidential, intellectual property and are protected under law. © INTEGRITY SIGN COMPANY 2008
 The prices, specifications and conditions are subject to change without notice. Integrity Sign Company is authorized to do the work as specified.

| | |
|--------------------------|--------------------------|
| Project: | |
| Address: | |
| Current Date: 11/25/2018 | File Name: 1358 w 47m PS |
| Drawn By: JS | Salesperson: |
| Approved By: | Date: |





05/28/2014

Alderman **Willie Cochran**
Ward # **20**
City of Chicago
City Hall, Room **300**
121 North LaSalle Street
Chicago, Illinois 60602

Re: An ordinance to use and maintain a portion of the public right-of-way for **one (1) sign(s)** for **DOLEX DOLLAR EXPRESS, INC.**, adjacent to the premises known as **1838 W. 47th St.**

Dear Alderman **Willie Cochran**:

The applicant referenced above has requested the use of the public right-of-way for a **sign(s)**. An ordinance has been prepared by the Department of Business Affairs and Consumer Protection – Small Business Center - Public Way Use Unit for presentation to the City Council. Because this request was made for properties located in your ward, as approved by you as per the attached, I respectfully request that you introduce the attached ordinance at the next City Council meeting.

If you have any questions regarding this ordinance, please contact Anthony Bertuca at (312) 744-5506.

Department of Business Affairs and Consumer Protection



City of Chicago



O2014-4745

Office of the City Clerk

Document Tracking Sheet

| | |
|---------------------------------|--|
| Meeting Date: | 5/28/2014 |
| Sponsor(s): | Brookins (21) |
| Type: | Ordinance |
| Title: | Grant(s) of privilege in public way for H & W Dental |
| Committee(s) Assignment: | Committee on Transportation and Public Way |

ORDINANCE
H & W DENTAL
Acct. No. 370689 - 1
Permit No. 1111279

Be It Ordained by the City Council of the City of Chicago:

SECTION 1. Permission and authority are hereby given and granted to H & W DENTAL, upon the terms and subject to the conditions of this ordinance to maintain and use one (1) sign(s) projecting over the public right-of-way attached to its premises known as 9612 S. Halsted St..

Said sign structure(s) measures as follows; along S. Halsted Street:
One (1) at twelve (12) feet in length, three (3) feet in height and nineteen point seven five (19.75) feet above grade level.

The location of said privilege shall be as shown on prints kept on file with the Department of Business Affairs and Consumer Protection and the Office of the City Clerk

Said privilege shall be constructed in accordance with plans and specifications approved by the Department of Transportation (Division of Project Development) and Zoning Department- Signs.

This grant of privilege in the public way shall be subject to the provisions of Section 10-28-015 and all other required provisions of the Municipal Code of Chicago.

The grantee shall pay to the City of Chicago as compensation for the privilege #1111279 herein granted the sum of three hundred (\$300.00) per annum in advance.

A 25% penalty will be added for payments received after due date

The permit holder agrees to hold the City of Chicago harmless for any damage, relocation or replacement costs associated with damage, relocation or removal of private property caused by the City performing work in the public way.

Authority herein given and granted for a period of five (5) years from and after Date of Passage.

Alderman 
Howard Brookins, Jr. 21st Ward

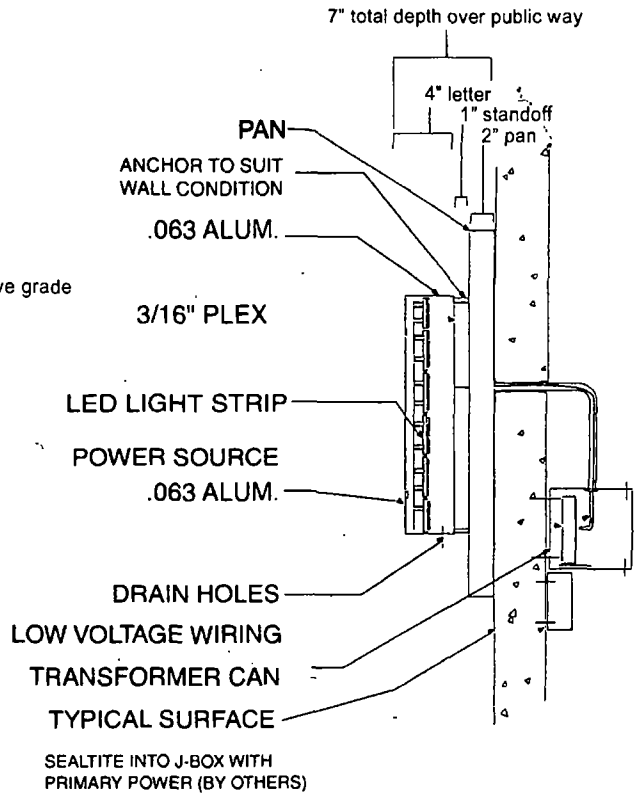
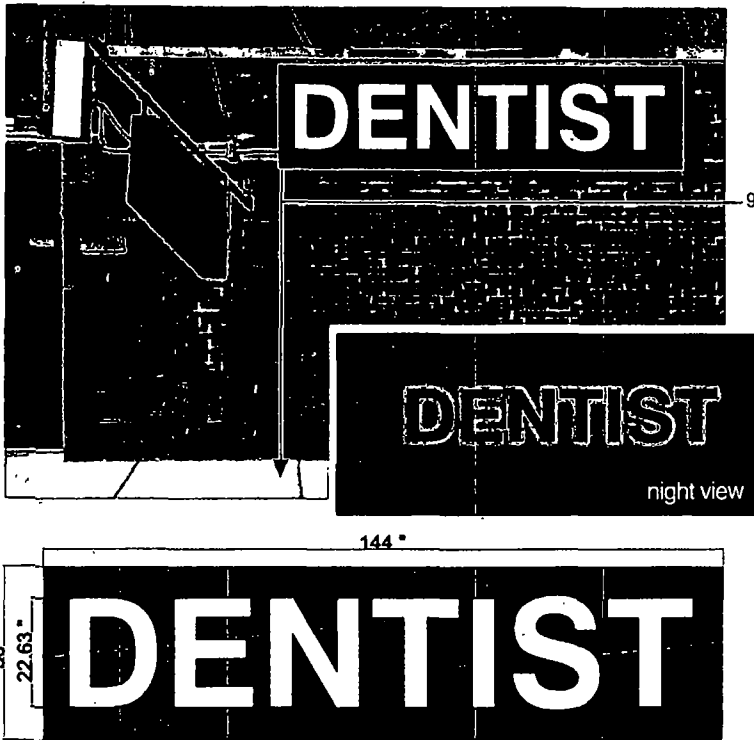

| | | | |
|--|---------------------------------------|---|------------------------------|
| <p>These drawings are the exclusive property of Integrity Sign Company. Any use other than that intended is not allowed without the express written authorization of Integrity Sign Company. Ideas contained herein are considered intellectual property and are protected under law. © Integrity Sign Company. The prices, specifications and conditions as described are satisfactory and hereby accepted. Integrity Sign Company is authorized to do the work as specified.</p> | Directory Name: \\DESIGN\JobFiles (D) |  <p>18621 S. 81st Ave. Tinley Park, IL 60487 708-532-5038 708-532-5059</p> | |
| | Customer: | | Address: |
| | Current Date: 11/25/2013 | | File Name: WALLACE DENTAL.fs |
| | Drawn By: JS | | Salesperson: |
| | Approved By: | | Date: |



05/28/2014

Alderman Howard Brookins, Jr.

Ward # 21

City of Chicago

City Hall, Room **300**

121 North LaSalle Street

Chicago, Illinois 60602

Re: An ordinance to use and maintain a portion of the public right-of-way for **one (1) sign(s)** for **H & W DENTAL**, adjacent to the premises known as **9612 S. Halsted St.**

Dear Alderman **Howard Brookins, Jr.:**

The applicant referenced above has requested the use of the public right-of-way for a **sign(s)**. An ordinance has been prepared by the Department of Business Affairs and Consumer Protection – Small Business Center - Public Way Use Unit for presentation to the City Council. Because this request was made for properties located in your ward, as approved by you as per the attached, I respectfully request that you introduce the attached ordinance at the next City Council meeting.

If you have any questions regarding this ordinance, please contact Anthony Bertuca at (312) 744-5506.

Department of Business Affairs and Consumer Protection



City of Chicago



O2014-4746

Office of the City Clerk

Document Tracking Sheet

| | |
|---------------------------------|---|
| Meeting Date: | 5/28/2014 |
| Sponsor(s): | Munoz (22) |
| Type: | Ordinance |
| Title: | Grant(s) of privilege in public way for Restaurante Alanis Ltd. |
| Committee(s) Assignment: | Committee on Transportation and Public Way |

ORDINANCE
RESTAURANTE ALANIS LTD
Acct. No. 62779 - 2
Permit No. 1110622

Be It Ordained by the City Council of the City of Chicago:

SECTION 1. Permission and authority are hereby given and granted to RESTAURANTE ALANIS LTD, upon the terms and subject to the conditions of this ordinance to maintain and use, as now constructed, two (2) Security Camera(s) projecting over the public right-of-way for security purposes adjacent to its premises known as 4153 W. 26th St..

Said Security Camera(s) at W. 26th Street measure(s):

Two (2) at point four two (.42) feet in length, point two five (.25) feet in width and nine (9) feet above grade level.

The location of said privilege shall be as shown on prints kept on file with the Department of Business Affairs and Consumer Protection and the Office of the City Clerk.

Said privilege shall be constructed in accordance with plans and specifications approved by the Department of Planning and Development and Department of Transportation (Division of Project Development).

This grant of privilege in the public way shall be subject to the provisions of Section 10-28-015 and all other required provisions of the Municipal Code of Chicago.

The grantee shall pay to the City of Chicago as compensation for the privilege #1110622 herein granted the sum of zero (\$0.00) per annum in advance.

A 25% penalty will be added for payments received after due date.

The permit holder agrees to hold the City of Chicago harmless for any damage, relocation or replacement costs associated with damage, relocation or removal of private property caused by the City performing work in the public way.

Authority herein given and granted for a period of five (5) years from and after 01/13/2014.

Alderman 
Ricardo Munoz 22nd Ward

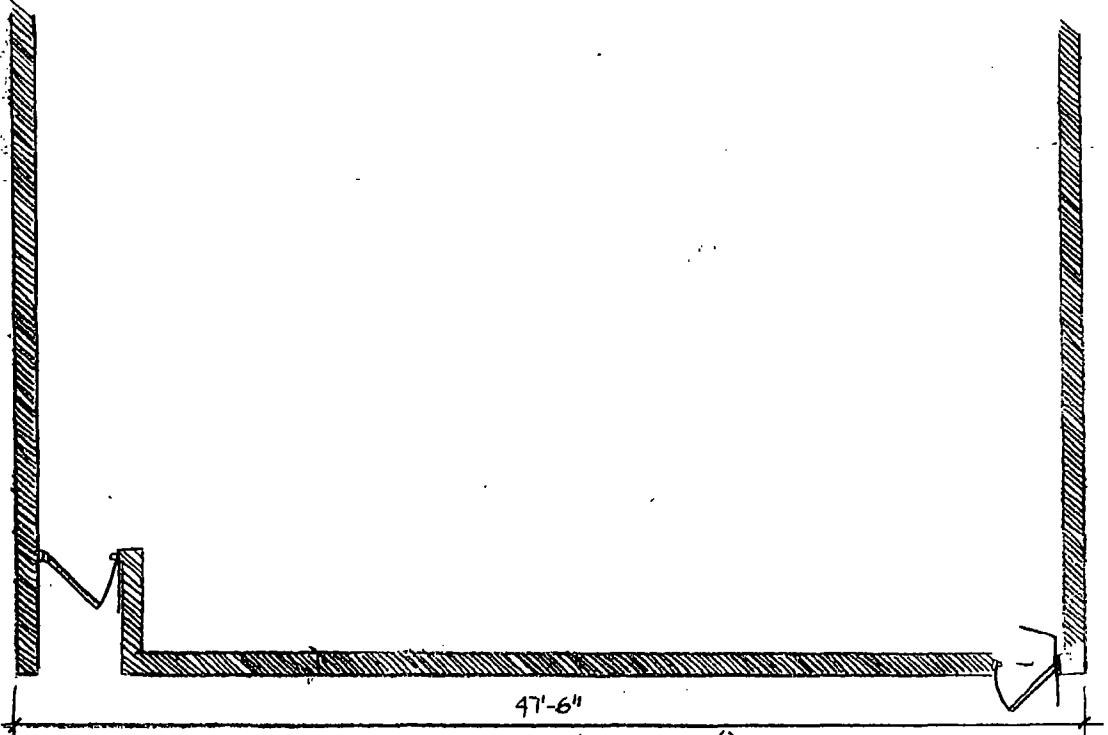

SIDE WALK
2 at Point .42 Feet in length
Point .25 Feet in width
and 9 Feet above grade level



City of Chicago



O2014-4747

Office of the City Clerk

Document Tracking Sheet

| | |
|---------------------------------|--|
| Meeting Date: | 5/28/2014 |
| Sponsor(s): | Zalewski (23) |
| Type: | Ordinance |
| Title: | Grant(s) of privilege in public way for Allstate Insurance |
| Committee(s) Assignment: | Committee on Transportation and Public Way |

ORDINANCE
ALLSTATE INSURANCE
Acct. No. 384748 - 1
Permit No. 1108585

Be It Ordained by the City Council of the City of Chicago:

SECTION 1. Permission and authority are hereby given and granted to ALLSTATE INSURANCE, upon the terms and subject to the conditions of this ordinance to maintain and use one (1) sign(s) projecting over the public right-of-way attached to its premises known as 5657 S. Harlem Ave..

Said sign structure(s) measures as follows; along S. Harlem Avenue:

One (1) at seven point two five (7.25) feet in length, four (4) feet in height and ten (10) feet above grade level.

The location of said privilege shall be as shown on prints kept on file with the Department of Business Affairs and Consumer Protection and the Office of the City Clerk.

Said privilege shall be constructed in accordance with plans and specifications approved by the Department of Transportation (Division of Project Development) and Zoning Department - Signs.

This grant of privilege in the public way shall be subject to the provisions of Section 10-28-015 and all other required provisions of the Municipal Code of Chicago.

The grantee shall pay to the City of Chicago as compensation for the privilege #1108585 herein granted the sum of three hundred (\$300.00) per annum in advance.

A 25% penalty will be added for payments received after due date.

The permit holder agrees to hold the City of Chicago harmless for any damage, relocation or replacement costs associated with damage, relocation or removal of private property caused by the City performing work in the public way.

Authority herein given and granted for a period of five (5) years from and after Date of Passage.

Alderman

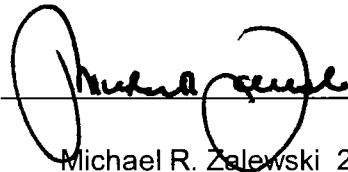

Michael R. Zelewski 23rd Ward

ENGINEERING SHOP VINYL / LAYOUT ROUTING / KNIFE

PERMITS ONLY

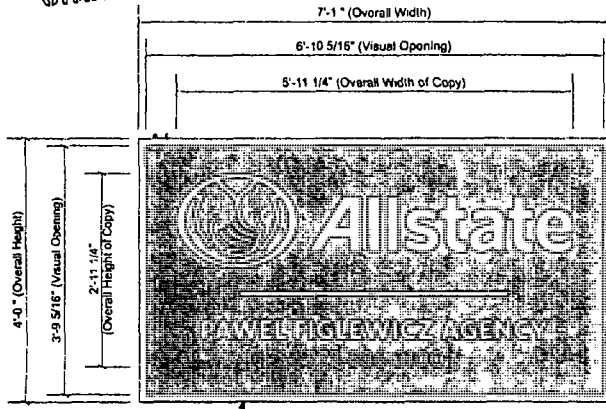

ELEVATION VIEW
E02 - AL ST. CUST. SIGN
Custom Cabinet Sign (4'-0" h x 7'-3" w)
 SCALE: 3/4" = 1'-0"

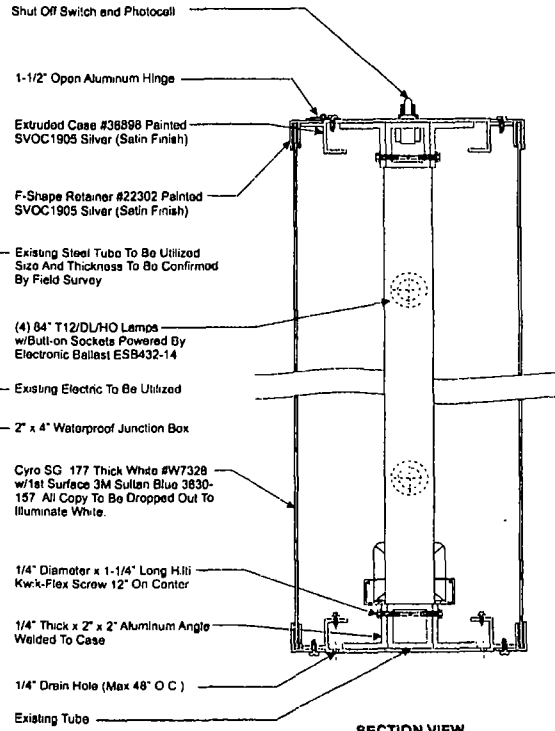

SECTION VIEW
 SCALE 3" = 1'-0"

NOTE: Need To Confirm Tubes Go All The Way Through Sign

NOTE: Minimum Steel Required 1/4" Thick x 2" x 2"

NOTE: All Dimensions To Be Verified From Site Survey Before Releasing For Fabrication

Electrical Load
 (2.34) Amps @ 120 Volts
Electrical Reqs.
 (1) 20 Amp/120 Volt Circuits

STANDARD WALL SIGN NOTES:

1. Sufficient Primary Circuit In Vicinity Of Sign By Others
2. Final Primary Hook-up By Sign Installer, Where Allowed By Local Codes.
3. Sign Shall Be U.L. Listed.
4. Mounting Hardware By Sign Installer

Note: This sign is intended to be installed in accordance with the requirements of Article 600 of the National Electrical Code and/or other applicable local codes. This includes proper grounding and bonding of the sign.

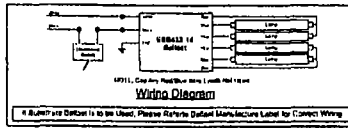

PHILADELPHIASIGN
 787 West Spring Garden Street
 Palmyra, New Jersey 08055
 Phone: 610.229.1480
 Fax: 610.229.8549
 www.philadelphiasign.com

| | |
|-----------------------|---|
| CUSTOMER: | ALLSTATE |
| JOB NUMBER: | IL6AD |
| SIGN TYPE: | Cabinet Sign |
| LOCATION: | 5657 S. Harlem Ave Chicago, IL 60638 |
| DATE: | 07/09/2013 |
| DRAWN BY: | JTR |
| REVISION: | Number Date By |
| SHEET: | 1 OF 1 END COPY |
| DWG NUMBER: | B49501 |
| ENGINEER SEAL: | |

MAX DESIGN WIND SPEED 90 MPH EXPOSURE C

THIS IS AN ELECTRICAL ENGINEERING DRAWING. IT IS THE RESPONSIBILITY OF THE ENGINEER TO VERIFY THE ACCURACY OF ALL INFORMATION PROVIDED BY THE CLIENT. THE ENGINEER ASSUMES NO LIABILITY FOR ANY DAMAGE OR LOSS OF PROFITS OR BUSINESS INTERRUPTIONS RESULTING FROM THE USE OF THIS DRAWING. THE ENGINEER'S OBLIGATION IS LIMITED TO THE DESIGN AND CONSTRUCTION OF THE SIGN. THE ENGINEER DOES NOT GUARANTEE THE PERFORMANCE OF THE SIGN OR THE RESULTS OF ANY TESTS PERFORMED THEREON. THE ENGINEER'S LIABILITY IS LIMITED TO THE DESIGN AND CONSTRUCTION OF THE SIGN.



05/28/2014

Alderman **Michael R. Zalewski**
Ward # **23**
City of Chicago
City Hall, Room **203**
121 North LaSalle Street
Chicago, Illinois 60602

Re: An ordinance to use and maintain a portion of the public right-of-way for **one (1) sign(s)** for **ALLSTATE INSURANCE**, adjacent to the premises known as **5657 S. Harlem Ave.**

Dear Alderman **Michael R. Zalewski**:

The applicant referenced above has requested the use of the public right-of-way for a **sign(s)**. An ordinance has been prepared by the Department of Business Affairs and Consumer Protection – Small Business Center - Public Way Use Unit for presentation to the City Council. Because this request was made for properties located in your ward, as approved by you as per the attached, I respectfully request that you introduce the attached ordinance at the next City Council meeting.

If you have any questions regarding this ordinance, please contact Anthony Bertuca at (312) 744-5506.

Department of Business Affairs and Consumer Protection



City of Chicago



O2014-4748

Office of the City Clerk

Document Tracking Sheet

| | |
|---------------------------------|---|
| Meeting Date: | 5/28/2014 |
| Sponsor(s): | Zalewski (23) |
| Type: | Ordinance |
| Title: | Grant(s) of privilege in public way for Dunkin Donuts |
| Committee(s) Assignment: | Committee on Transportation and Public Way |

ORDINANCE
DUNKIN DONUTS
Acct. No. 14398 - 3
Permit No. 1112982

Be It Ordained by the City Council of the City of Chicago:

SECTION 1. Permission and authority are hereby given and granted to DUNKIN DONUTS, upon the terms and subject to the conditions of this ordinance to maintain and use, as now constructed, two (2) Landscaping(s) on the public right-of-way for beautification purposes adjacent to its premises known as 5615 S. Harlem Ave..

Said Landscaping(s) at S. Harlem measure(s):

One (1) at eighty-six point six six (86.66) feet in length, and six (6) feet in width for a total of five hundred nineteen point nine six (519.96) square feet.

Said Landscaping(s) at S. Harlem measure(s):

One (1) at twenty-four (24) feet in length, and six (6) feet in width for a total of one hundred forty-four (144) square feet.

The location of said privilege shall be as shown on prints kept on file with the Department of Business Affairs and Consumer Protection and the Office of the City Clerk.

Said privilege shall be constructed in accordance with plans and specifications approved by the Department of Planning and Development and Department of Transportation (Division of Project Development).

This grant of privilege in the public way shall be subject to the provisions of Section 10-28-015 and all other required provisions of the Municipal Code of Chicago.

The grantee shall pay to the City of Chicago as compensation for the privilege #1112982 herein granted the sum of zero (\$0.00) per annum in advance.

A 25% penalty will be added for payments received after due date.

The permit holder agrees to hold the City of Chicago harmless for any damage, relocation or replacement costs associated with damage, relocation or removal of private property caused by the City performing work in the public way.

Authority herein given and granted for a period of five (5) years from and after 01/13/2014.

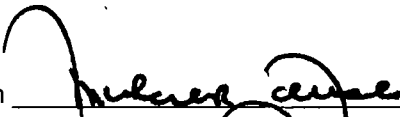
Alderman 
Michael R. Zalewski 23rd Ward

THIS DOES NOT CONSTITUTE A BOUNDARY SURVEY

This mortgage inspection and drawing is not a boundary survey or plat of survey. This mortgage inspection was prepared to assist the mortgage company and title insurance company and is not to be used for any purposes of boundary disputes; location of actual deed, title or platted lines, or for construction of new improvements; Graphic representation shall be deemed approximate and no reliance should be placed on the scale of the drawing. This plat title and paragraph have been added in accordance with 68Ill. Adm. Code 1270.56.

LEGAL DESCRIPTION:

LOTS 20, 21, 22, 23 AND 24 IN BLOCK 105 IN FREDERICK H. BARTLETT'S SIXTH ADDITION TO BARTLETT HIGHLANDS, BEING A SUBDIVISION OF THE NORTHWEST 1/4 OF SECTION 18, TOWNSHIP 38 NORTH, RANGE 13, EAST OF THE THIRD PRINCIPAL MERIDIAN, IN COOK COUNTY, ILLINOIS.

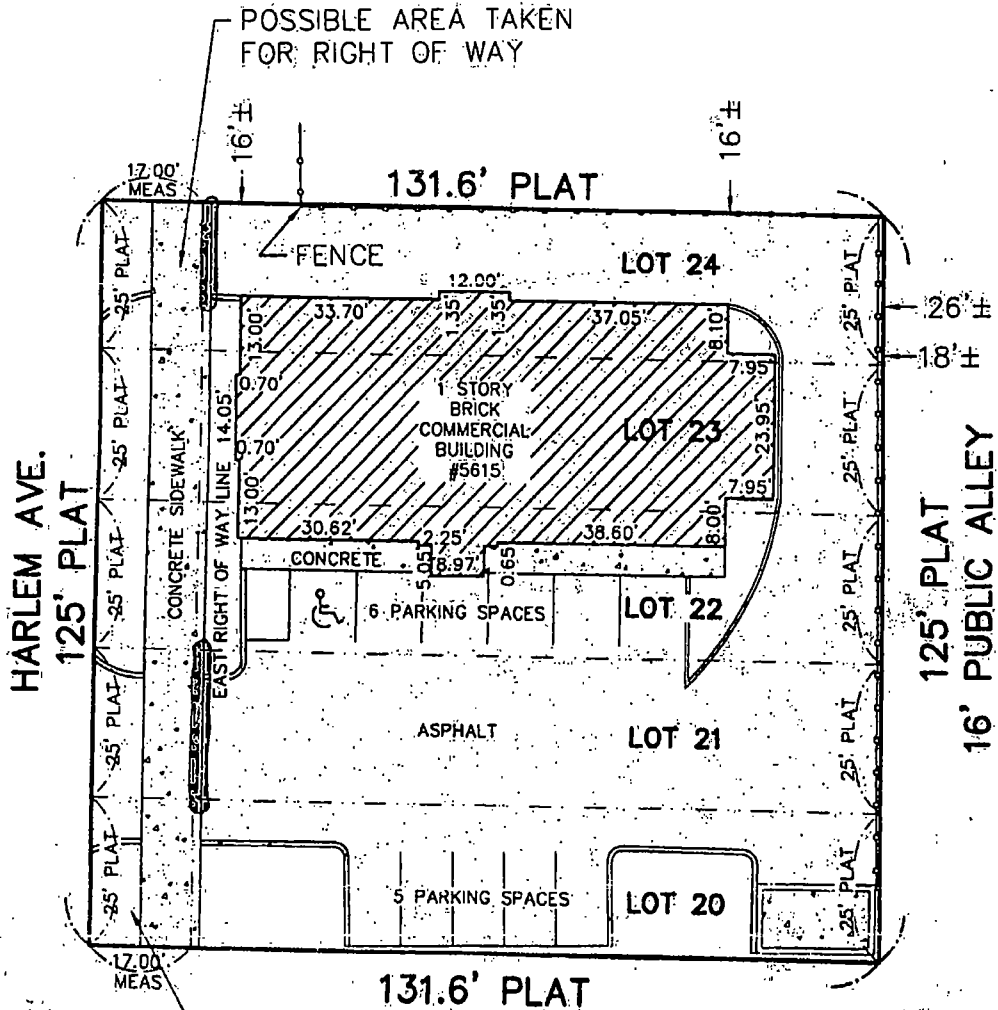

Entrances

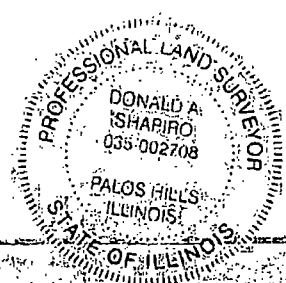

STATE OF ILLINOIS)
COUNTY OF COOK) s.s.

On behalf of Shapiro Surveying PC, I hereby certify that the above described property was surveyed under my supervision and that the annexed plat is a correct representation of said survey. This professional service conforms to the current Illinois minimum standards for a mortgage inspection and is not a boundary survey.

All distances shown are in feet and decimal parts thereof. No distances are to be determined by scaling.

Dated: 08/10/04

RY: Donald A. Shapiro



05/28/2014

Alderman **Michael R. Zalewski**
Ward # **23**
City of Chicago
City Hall, Room **203**
121 North LaSalle Street
Chicago, Illinois 60602

Re: An ordinance to use and maintain a portion of the public right-of-way for **two (2) landscaping(s)** for **DUNKIN DONUTS**, adjacent to the premises known as **5615 S. Harlem Ave.**

Dear Alderman **Michael R. Zalewski**:

The applicant referenced above has requested the use of the public right-of-way for a **landscaping(s)**. An ordinance has been prepared by the Department of Business Affairs and Consumer Protection – Small Business Center - Public Way Use Unit for presentation to the City Council. Because this request was made for properties located in your ward, as approved by you as per the attached, I respectfully request that you introduce the attached ordinance at the next City Council meeting.

If you have any questions regarding this ordinance, please contact Anthony Bertuca at (312) 744-5506.

Department of Business Affairs and Consumer Protection



City of Chicago



O2014-4749

Office of the City Clerk

Document Tracking Sheet

| | |
|---------------------------------|---|
| Meeting Date: | 5/28/2014 |
| Sponsor(s): | Zalewski (23) |
| Type: | Ordinance |
| Title: | Grant(s) of privilege in public way for Moran Body Shop |
| Committee(s) Assignment: | Committee on Transportation and Public Way |

ORDINANCE
MORAN BODY SHOP
Acct. No. 41071 - 2
Permit No. 1112658

Be It Ordained by the City Council of the City of Chicago:

SECTION 1. Permission and authority are hereby given and granted to MORAN BODY SHOP, upon the terms and subject to the conditions of this ordinance to maintain and use one (1) sign(s) projecting over the public right-of-way attached to its premises known as 5243 S. Archer Ave..

Said sign structure(s) measures as follows; along S. ARCHER AVE.:
One (1) at six (6) feet in length, four (4) feet in height and ten (10) feet above grade level.

The location of said privilege shall be as shown on prints kept on file with the Department of Business Affairs and Consumer Protection and the Office of the City Clerk.

Said privilege shall be constructed in accordance with plans and specifications approved by the Department of Transportation (Division of Project Development) and Zoning Department - Signs.

This grant of privilege in the public way shall be subject to the provisions of Section 10-28-015 and all other required provisions of the Municipal Code of Chicago.

The grantee shall pay to the City of Chicago as compensation for the privilege #1112658 herein granted the sum of one hundred (\$100.00) per annum in advance.

A 25% penalty will be added for payments received after due date.

The permit holder agrees to hold the City of Chicago harmless for any damage, relocation or replacement costs associated with damage, relocation or removal of private property caused by the City performing work in the public way.

Authority herein given and granted for a period of five (5) years from and after 07/30/2013.

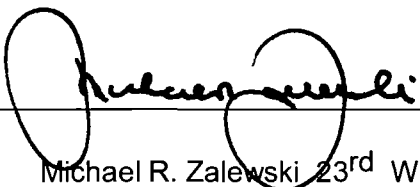
Alderman  _____
Michael R. Zalewski 23rd Ward

2000

5243 S. Archer





05/28/2014

Alderman **Michael R. Zalewski**
Ward # **23**
City of Chicago
City Hall, Room **203**
121 North LaSalle Street
Chicago, Illinois 60602

Re: An ordinance to use and maintain a portion of the public right-of-way for **one (1) sign(s)** for
MORAN BODY SHOP, adjacent to the premises known as **5243 S. Archer Ave.**

Dear Alderman **Michael R. Zalewski**:

The applicant referenced above has requested the use of the public right-of-way for a **sign(s)**. An ordinance has been prepared by the Department of Business Affairs and Consumer Protection – Small Business Center - Public Way Use Unit for presentation to the City Council. Because this request was made for properties located in your ward, as approved by you as per the attached, I respectfully request that you introduce the attached ordinance at the next City Council meeting.

If you have any questions regarding this ordinance, please contact Anthony Bertuca at (312) 744-5506.

Department of Business Affairs and Consumer Protection



City of Chicago



O2014-4751

Office of the City Clerk

Document Tracking Sheet

| | |
|---------------------------------|--|
| Meeting Date: | 5/28/2014 |
| Sponsor(s): | Chandler (24) |
| Type: | Ordinance |
| Title: | Grant(s) of privilege in public way for Ivory Cleaners |
| Committee(s) Assignment: | Committee on Transportation and Public Way |

ORDINANCE
IVORY CLEANERS
Acct. No. 51239 - 1
Permit No. 1110589

Be It Ordained by the City Council of the City of Chicago:

SECTION 1. Permission and authority are hereby given and granted to IVORY CLEANERS, upon the terms and subject to the conditions of this ordinance to maintain and use one (1) sign(s) projecting over the public right-of-way attached to its premises known as 3857 W. Roosevelt Rd..

Said sign structure(s) measures as follows; along W. Roosevelt Rd:
One (1) at four (4) feet in length, six (6) feet in height and thirteen (13) feet above grade level.

The location of said privilege shall be as shown on prints kept on file with the Department of Business Affairs and Consumer Protection and the Office of the City Clerk.

Said privilege shall be constructed in accordance with plans and specifications approved by the Department of Transportation (Division of Project Development) and Zoning Department - Signs.

This grant of privilege in the public way shall be subject to the provisions of Section 10-28-015 and all other required provisions of the Municipal Code of Chicago.

The grantee shall pay to the City of Chicago as compensation for the privilege #1110589 herein granted the sum of one hundred (\$100.00) per annum in advance.

A 25% penalty will be added for payments received after due date.

The permit holder agrees to hold the City of Chicago harmless for any damage, relocation or replacement costs associated with damage, relocation or removal of private property caused by the City performing work in the public way.

Authority herein given and granted for a period of five (5) years from and after 12/17/2013.

Alderman



Michael D. Chandler 24th Ward





2nd ATTEMPT AT INTRODUCTION

05/28/2014

Alderman **Michael D. Chandler**
Ward # 24
City of Chicago
City Hall, Room 203
121 North LaSalle Street
Chicago, Illinois 60602

Re: An ordinance to use and maintain a portion of the public right-of-way for **one (1) sign(s)** for **IVORY CLEANERS**, adjacent to the premises known as **3857 W. Roosevelt Rd.**

Dear Alderman **Michael D. Chandler**:

The applicant referenced above has requested the use of the public right-of-way for a **sign(s)**. An ordinance has been prepared by the Department of Business Affairs and Consumer Protection – Small Business Center - Public Way Use Unit for presentation to the City Council. Because this request was made for properties located in your ward, as approved by you as per the attached, I respectfully request that you introduce the attached ordinance at the next City Council meeting.

If you have any questions regarding this ordinance, please contact Anthony Bertuca at (312) 744-5506.

Department of Business Affairs and Consumer Protection



City of Chicago



O2014-4752

Office of the City Clerk Document Tracking Sheet

| | |
|---------------------------------|--|
| Meeting Date: | 5/28/2014 |
| Sponsor(s): | Chandler (24) |
| Type: | Ordinance |
| Title: | Grant(s) of privilege in public way for La Azteca Paeteria |
| Committee(s) Assignment: | Committee on Transportation and Public Way |

ORDINANCE
LA AZTECA PALETERIA
Acct. No. 259063 - 2
Permit No. 1111044

Be It Ordained by the City Council of the City of Chicago:

SECTION 1. Permission and authority are hereby given and granted to LA AZTECA PALETERIA, upon the terms and subject to the conditions of this ordinance to maintain and use one (1) sign(s) projecting over the public right-of-way attached to its premises known as 3018 W. Cermak Rd..

Said sign structure(s) measures as follows; along W. Cermak Road:

One (1) at four point four two (4.42) feet in length, five (5) feet in height and fourteen point three three (14.33) feet above grade level.

The location of said privilege shall be as shown on prints kept on file with the Department of Business Affairs and Consumer Protection and the Office of the City Clerk.

Said privilege shall be constructed in accordance with plans and specifications approved by the Department of Transportation (Division of Project Development) and Zoning Department - Signs.

This grant of privilege in the public way shall be subject to the provisions of Section 10-28-015 and all other required provisions of the Municipal Code of Chicago.

The grantee shall pay to the City of Chicago as compensation for the privilege #1111044 herein granted the sum of one hundred (\$100.00) per annum in advance.

A 25% penalty will be added for payments received after due date.

The permit holder agrees to hold the City of Chicago harmless for any damage, relocation or replacement costs associated with damage, relocation or removal of private property caused by the City performing work in the public way.

Authority herein given and granted for a period of five (5) years from and after 01/13/2014.

Alderman 

Michael D. Chandler 24th Ward





2nd ATTEMPT AT INTRODUCTION

05/28/2014

Alderman **Michael D. Chandler**
Ward # 24
City of Chicago
City Hall, Room 203
121 North LaSalle Street
Chicago, Illinois 60602

Re: An ordinance to use and maintain a portion of the public right-of-way for **one (1) sign(s)** for **LA AZTECA PALETERIA**, adjacent to the premises known as **3018 W. Cermak Rd.**.

Dear Alderman **Michael D. Chandler**:

The applicant referenced above has requested the use of the public right-of-way for a **sign(s)**. An ordinance has been prepared by the Department of Business Affairs and Consumer Protection – Small Business Center - Public Way Use Unit for presentation to the City Council. Because this request was made for properties located in your ward, as approved by you as per the attached, I respectfully request that you introduce the attached ordinance at the next City Council meeting.

If you have any questions regarding this ordinance, please contact Anthony Bertuca at (312) 744-5506.

Department of Business Affairs and Consumer Protection



City of Chicago



O2014-4753

Office of the City Clerk Document Tracking Sheet

| | |
|---------------------------------|---|
| Meeting Date: | 5/28/2014 |
| Sponsor(s): | Chandler (24) |
| Type: | Ordinance |
| Title: | Grant(s) of privilege in public way for Rothchild Liquors |
| Committee(s) Assignment: | Committee on Transportation and Public Way |

ORDINANCE
ROTHSCHILD LIQUORS
Acct. No. 63343 - 2
Permit No. 1110734

Be It Ordained by the City Council of the City of Chicago:

SECTION 1. Permission and authority are hereby given and granted to ROTHSCCHILD LIQUORS, upon the terms and subject to the conditions of this ordinance to maintain and use, as now constructed, two (2) Security Camera(s) projecting over the public right-of-way for security purposes adjacent to its premises known as 3530 W. Roosevelt Rd..

Said Security Camera(s) at W. Roosevelt Road measure(s):

Two (2) at point eight three (.83) feet in length, point three three (.33) feet in width and thirteen (13) feet above grade level.

The location of said privilege shall be as shown on prints kept on file with the Department of Business Affairs and Consumer Protection and the Office of the City Clerk.

Said privilege shall be constructed in accordance with plans and specifications approved by the Department of Planning and Development and Department of Transportation (Division of Project Development).

This grant of privilege in the public way shall be subject to the provisions of Section 10-28-015 and all other required provisions of the Municipal Code of Chicago.

The grantee shall pay to the City of Chicago as compensation for the privilege #1110734 herein granted the sum of zero (\$.00) per annum in advance.

A 25% penalty will be added for payments received after due date.

The permit holder agrees to hold the City of Chicago harmless for any damage, relocation or replacement costs associated with damage, relocation or removal of private property caused by the City performing work in the public way.

Authority herein given and granted for a period of five (5) years from and after 01/13/2014.

Alderman

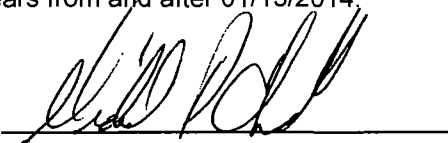

Michael D. Chandler 24th Ward



#12 Rothschild Liquor Mart
3530 W. Roosevelt Rd.
Chicago, IL. 60624



2nd ATTEMPT AT INTRODUCTION

05/28/2014

Alderman **Michael D. Chandler**
Ward # 24
City of Chicago
City Hall, Room 203
121 North LaSalle Street
Chicago, Illinois 60602

Re: An ordinance to use and maintain a portion of the public right-of-way for **two (2) security camera(s)** for **ROTHSCHILD LIQUORS**, adjacent to the premises known as **3530 W. Roosevelt Rd.**

Dear Alderman **Michael D. Chandler**:

The applicant referenced above has requested the use of the public right-of-way for a **security camera(s)**. An ordinance has been prepared by the Department of Business Affairs and Consumer Protection – Small Business Center - Public Way Use Unit for presentation to the City Council. Because this request was made for properties located in your ward, as approved by you as per the attached, I respectfully request that you introduce the attached ordinance at the next City Council meeting.

If you have any questions regarding this ordinance, please contact Anthony Bertuca at (312) 744-5506.

Department of Business Affairs and Consumer Protection



City of Chicago



O2014-4754

Office of the City Clerk

Document Tracking Sheet

| | |
|---------------------------------|---|
| Meeting Date: | 5/28/2014 |
| Sponsor(s): | Solis (25) |
| Type: | Ordinance |
| Title: | Grant(s) of privilege in public way for Cell Com of Chicago, Inc. |
| Committee(s) Assignment: | Committee on Transportation and Public Way |

ORDINANCE

Cell Com of Chicago, Inc.
Acct. No. 355969 - 3
Permit No. 1111962

Be It Ordained by the City Council of the City of Chicago:

SECTION 1. Permission and authority are hereby given and granted to Cell Com of Chicago, Inc., upon the terms and subject to the conditions of this ordinance to maintain and use one (1) sign(s) projecting over the public right-of-way attached to its premises known as 1429 W. 18th St..

Said sign structure(s) measures as follows; along West 18th Street:

One (1) at eight point eight three (8.83) feet in length, two point five seven (2.57) feet in height and ten (10) feet above grade level.

The location of said privilege shall be as shown on prints kept on file with the Department of Business Affairs and Consumer Protection and the Office of the City Clerk.

Said privilege shall be constructed in accordance with plans and specifications approved by the Department of Transportation (Division of Project Development) and Zoning Department - Signs.

This grant of privilege in the public way shall be subject to the provisions of Section 10-28-015 and all other required provisions of the Municipal Code of Chicago.

The grantee shall pay to the City of Chicago as compensation for the privilege #1111962 herein granted the sum of one hundred (\$100.00) per annum in advance.

A 25% penalty will be added for payments received after due date.

The permit holder agrees to hold the City of Chicago harmless for any damage, relocation or replacement costs associated with damage, relocation or removal of private property caused by the City performing work in the public way.

Authority herein given and granted for a period of five (5) years from and after Date of Passage.

Alderman _____

Daniel S. Solis 25th Ward

2000

LED FACE LIT CHANNEL LETTERS
Scale: 1/2" = 1'-0" 22.9 square feet

16"
8'-10-1/2" Backer
8'-3/4"
2'-7" Backer
1'-4" 3/4"
2'-3/8"
4'-3/4"
4'-9"

dotted line represents raceway behind backer panel

MOBILE authorized retailer

MOBILE & DIGIT FACE: 3/16" thick #7328 White acrylic
RETURN: 040 alum 3" deep pre-finished Black

MOBILE & DIGIT TRIMCAP: 1" Black jewella trimcap
RETURN: 040 alum 3" deep pre-finished Black

BACKS: 083 alum pre-finished alum White
LED: Hyperion R-LTR HRL 07-CC 6500EE White LED's 120 volt
1" addition HRL-07-CC-6500EE LED Strip on Return for 1" only (24" or larger)

AUTHORIZED RETAILER: 1/2" thick flat cut out PVC Letters painted White, Drilled & tapped for stud mounting flush thru backer panel
Penetrations filled with silicone adhesive

BACKER PANEL: 090 alum backer painted 100% Black satin finish - no visible fasteners
Backer to be mounted raceway as required

RACEWAY: 6"x6" alum raceway to house electrical components - painted to match

LED CHANNEL - RACEWAY MOUNT

COLOR MATCHING

- ACRYCAST MX L0 14 Hot Pink
- 100% Black Satin Finish

EXISTING BANNER TO BE REMOVED & DISCARDED; PATCH & PAINT FACIA AS NEEDED

PROPOSED STOREFRONT SCALE 1/8" = 1'-0"

MC SIGN COMPANY
3959 TYLER BLVD.
MENTOR, OHIO 44060
TEL 440-208-8200
FAX 440-208-8277
www.mcsign.com

T-Mobile
1429 W 183RD ST
CHICAGO, IL 60664

| QUANTITY | DESCRIPTION | DATE | UNIT | REMARKS |
|---|-------------|----------|------|---------|
| 2 | 270561 | 07/24/13 | | |
| | MEGAN GARM | JR | | |
| TMO001241/WIRELESS DISTRIBUTION NETWORKS - LLLC/CHICAGO | | | | |

Sign On
Partner with the best

NOTE: PHOTOS ARE THE EXCLUSIVE PROPERTY OF "MC SIGN COMPANY" ANY UNAUTHORIZED USE OR REPRODUCTION WILL RESULT IN A 20% CHARGE PER OCCURRENCE PER THE VALUE OF THE DISPLAY. © MC SIGN CO 1998



05/28/2014

Alderman **Daniel S. Solis**
Ward # **25**
City of Chicago
City Hall, Room **203**
121 North LaSalle Street
Chicago, Illinois 60602

Re: An ordinance to use and maintain a portion of the public right-of-way for **one (1) sign(s)** for **Cell Com of Chicago, Inc.**, adjacent to the premises known as **1429 W. 18th St.**

Dear Alderman **Daniel S. Solis**:

The applicant referenced above has requested the use of the public right-of-way for a **sign(s)**. An ordinance has been prepared by the Department of Business Affairs and Consumer Protection – Small Business Center - Public Way Use Unit for presentation to the City Council. Because this request was made for properties located in your ward, as approved by you as per the attached, I respectfully request that you introduce the attached ordinance at the next City Council meeting.

If you have any questions regarding this ordinance, please contact Anthony Bertuca at (312) 744-5506.

Department of Business Affairs and Consumer Protection





City of Chicago



O2014-4756

Office of the City Clerk

Document Tracking Sheet

| | |
|---------------------------------|--|
| Meeting Date: | 5/28/2014 |
| Sponsor(s): | Solis (25) |
| Type: | Ordinance |
| Title: | Grant(s) of privilege in public way for Digital Green Sign |
| Committee(s) Assignment: | Committee on Transportation and Public Way |

ORDINANCE
Digital Green Sign
Acct. No. 376387 - 9
Permit No. 1104971

Be It Ordained by the City Council of the City of Chicago:

SECTION 1. Permission and authority are hereby given and granted to Digital Green Sign, upon the terms and subject to the conditions of this ordinance to maintain and use one (1) sign(s) projecting over the public right-of-way attached to its premises known as 2025 S. Western Ave..

Said sign structure(s) measures as follows; along Western:
One (1) at nine point five (9.5) feet in length, nine point five (9.5) feet in height and twenty (20) feet above grade level.

The location of said privilege shall be as shown on prints kept on file with the Department of Business Affairs and Consumer Protection and the Office of the City Clerk.

Said privilege shall be constructed in accordance with plans and specifications approved by the Department of Transportation (Division of Project Development) and Zoning Department - Signs.

This grant of privilege in the public way shall be subject to the provisions of Section 10-28-015 and all other required provisions of the Municipal Code of Chicago.

The grantee shall pay to the City of Chicago as compensation for the privilege #1104971 herein granted the sum of three hundred (\$300.00) per annum in advance.

A 25% penalty will be added for payments received after due date.

The permit holder agrees to hold the City of Chicago harmless for any damage, relocation or replacement costs associated with damage, relocation or removal of private property caused by the City performing work in the public way.

Authority herein given and granted for a period of five (5) years from and after Date of Passage.

Alderman _____

Daniel S. Solis 25th Ward

APPLICATION TO USE THE PUBLIC RIGHT OF WAY

EXAMPLE OF SIGN DRAWING



SIGN DRAWING

PROPERTY LOCATION: 3025 S. WESTERN AVE

ORGANIZATION(S) NAME: Digital Green Signs, LLC

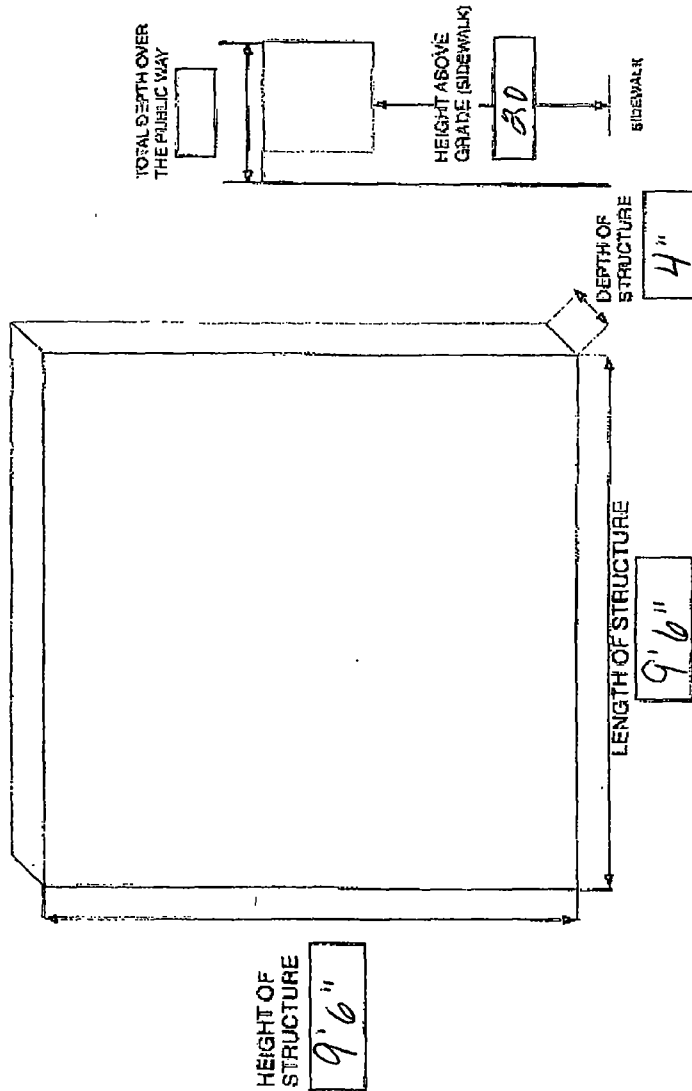



05/28/2014

Alderman **Daniel S. Solis**
Ward # **25**
City of Chicago
City Hall, Room **203**
121 North LaSalle Street
Chicago, Illinois 60602

Re: An ordinance to use and maintain a portion of the public right-of-way for **one (1) sign(s)** for **Digital Green Sign**, adjacent to the premises known as **2025 S. Western Ave.**.

Dear Alderman **Daniel S. Solis**:

The applicant referenced above has requested the use of the public right-of-way for a **sign(s)**. An ordinance has been prepared by the Department of Business Affairs and Consumer Protection – Small Business Center - Public Way Use Unit for presentation to the City Council. Because this request was made for properties located in your ward, as approved by you as per the attached, I respectfully request that you introduce the attached ordinance at the next City Council meeting.

If you have any questions regarding this ordinance, please contact Anthony Bertuca at (312) 744-5506.

Department of Business Affairs and Consumer Protection



City of Chicago



O2014-4758

Office of the City Clerk

Document Tracking Sheet

| | |
|---------------------------------|--|
| Meeting Date: | 5/28/2014 |
| Sponsor(s): | Solis (25) |
| Type: | Ordinance |
| Title: | Grant(s) of privilege in public way for Monterrey Security Consultants, Inc. |
| Committee(s) Assignment: | Committee on Transportation and Public Way |

ORDINANCE
MONTERREY SECURITY CONSULTANTS, INC.
Acct. No. 49748 - 2
Permit No. 1112933

Be It Ordained by the City Council of the City of Chicago:

SECTION 1. Permission and authority are hereby given and granted to MONTERREY SECURITY CONSULTANTS, INC., upon the terms and subject to the conditions of this ordinance to maintain and use two (2) sign(s) projecting over the public right-of-way attached to its premises known as 2232 S. Blue Island Ave..

Said sign structure(s) measures as follows; along S. BLUE ISLAND:
One (1) at twenty (20) feet in length, four (4) feet in height and twelve (12) feet above grade level.

Said sign structure(s) measures as follows; along 1649 W. CERMAK:
One (1) at eight (8) feet in length, four (4) feet in height and twelve (12) feet above grade level.

The location of said privilege shall be as shown on prints kept on file with the Department of Business Affairs and Consumer Protection and the Office of the City Clerk.

Said privilege shall be constructed in accordance with plans and specifications approved by the Department of Transportation (Division of Project Development) and Zoning Department - Signs.

This grant of privilege in the public way shall be subject to the provisions of Section 10-28-015 and all other required provisions of the Municipal Code of Chicago.

The grantee shall pay to the City of Chicago as compensation for the privilege #1112933 herein granted the sum of six hundred (\$600.00) per annum in advance.

A 25% penalty will be added for payments received after due date.

The permit holder agrees to hold the City of Chicago harmless for any damage, relocation or replacement costs associated with damage, relocation or removal of private property caused by the City performing work in the public way.

Authority herein given and granted for a period of five (5) years from and after 05/13/2014.

Alderman _____

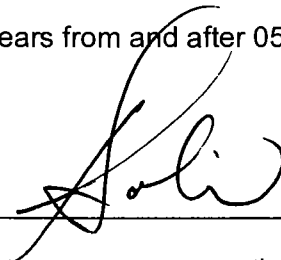

Daniel S. Solis 25th Ward

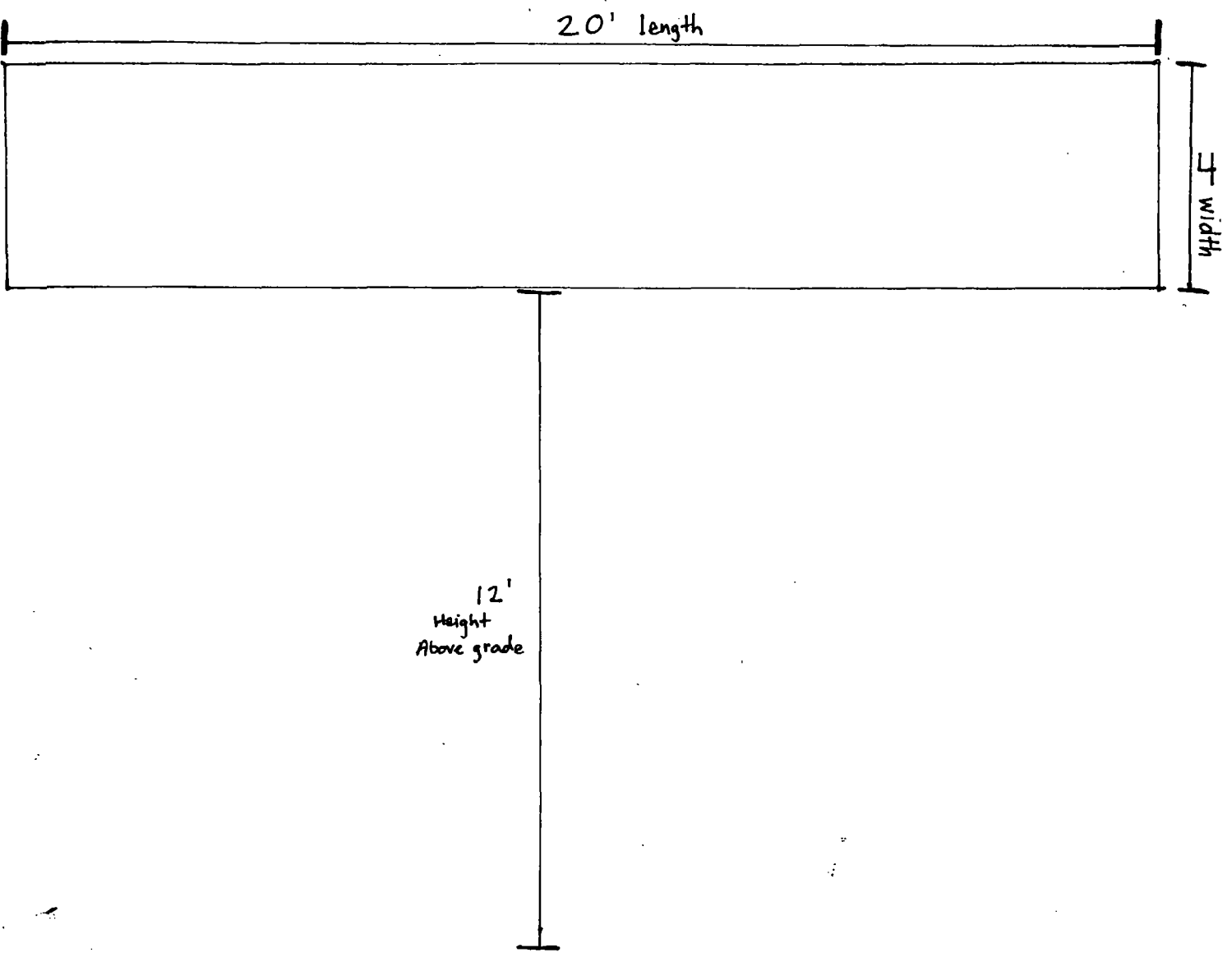

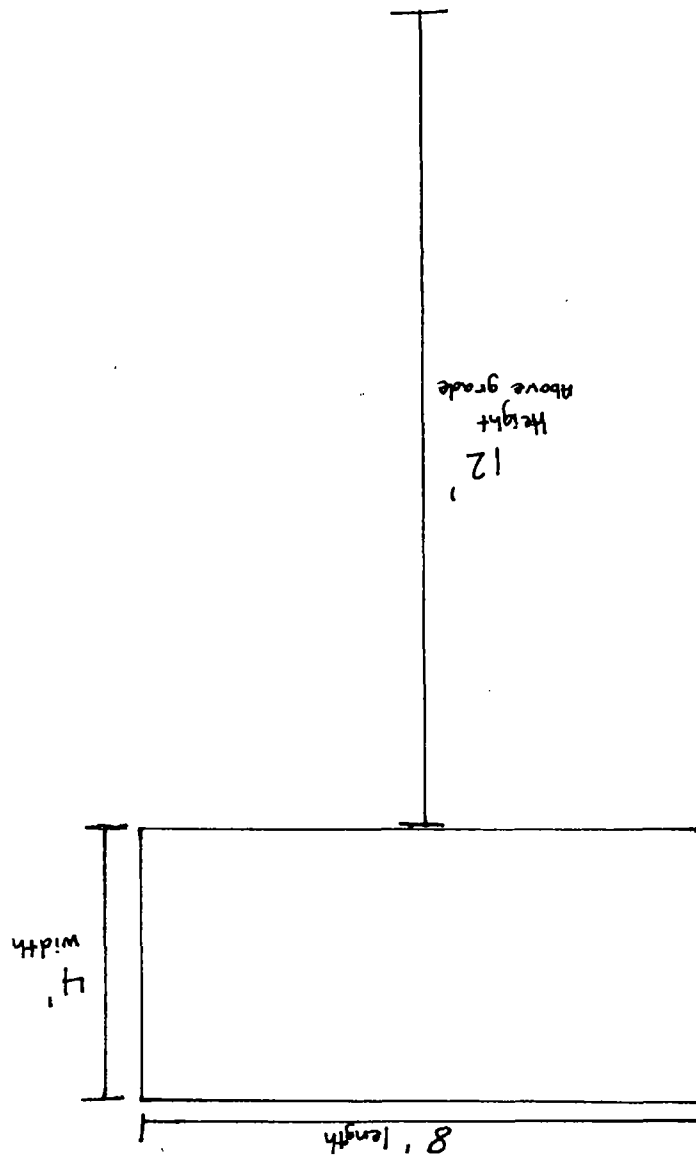



05/28/2014

Alderman **Daniel S. Solis**
Ward # **25**
City of Chicago
City Hall, Room **203**
121 North LaSalle Street
Chicago, Illinois 60602

Re: An ordinance to use and maintain a portion of the public right-of-way for **two (2) sign(s)** for
MONTERREY SECURITY CONSULTANTS, INC., adjacent to the premises known as **2232 S.**
Blue Island Ave.

Dear Alderman **Daniel S. Solis**:

The applicant referenced above has requested the use of the public right-of-way for a **sign(s)**. An ordinance has been prepared by the Department of Business Affairs and Consumer Protection – Small Business Center - Public Way Use Unit for presentation to the City Council. Because this request was made for properties located in your ward, as approved by you as per the attached, I respectfully request that you introduce the attached ordinance at the next City Council meeting.

If you have any questions regarding this ordinance, please contact Anthony Bertuca at (312) 744-5506.

Department of Business Affairs and Consumer Protection



City of Chicago



O2014-4759

Office of the City Clerk

Document Tracking Sheet

| | |
|---------------------------------|---|
| Meeting Date: | 5/28/2014 |
| Sponsor(s): | Solis (25) |
| Type: | Ordinance |
| Title: | Grant(s) of privilege in public way for Uncle Bob's Storage - banners |
| Committee(s) Assignment: | Committee on Transportation and Public Way |

ORDINANCE
UNCLE BOB'S STORAGE
Acct. No. 387869 - 1
Permit No. 1111737

Be It Ordained by the City Council of the City of Chicago:

SECTION 1. Permission and authority are hereby given and granted to UNCLE BOB'S STORAGE, upon the terms and subject to the conditions of this ordinance to construct, install, maintain and use four (4) Banner(s) projecting over the public right-of-way adjacent to its premises known as 1601-25 S. Ashland Ave..

Said Banner(s) at S Ashland Ave measure(s):

Four (4) at two (2) feet in length, and four point eight three (4.83) feet in width for a total of thirty-eight point six four (38.64) square feet.

The location of said privilege shall be as shown on prints kept on file with the Department of Business Affairs and Consumer Protection and the Office of the City Clerk.

Said privilege shall be constructed in accordance with plans and specifications approved by the Zoning Department - Signs.

This grant of privilege in the public way shall be subject to the provisions of Section 10-28-015 and all other required provisions of the Municipal Code of Chicago.

The grantee shall pay to the City of Chicago as compensation for the privilege #1111737 herein granted the sum of one hundred seventy-five (\$175.00) per annum in advance.

A 25% penalty will be added for payments received after due date.

The permit holder agrees to hold the City of Chicago harmless for any damage, relocation or replacement costs associated with damage, relocation or removal of private property caused by the City performing work in the public way.

Authority herein given and granted for a period of five (5) years from and after Date of Passage.

Alderman _____

Daniel S. Solis 25th Ward

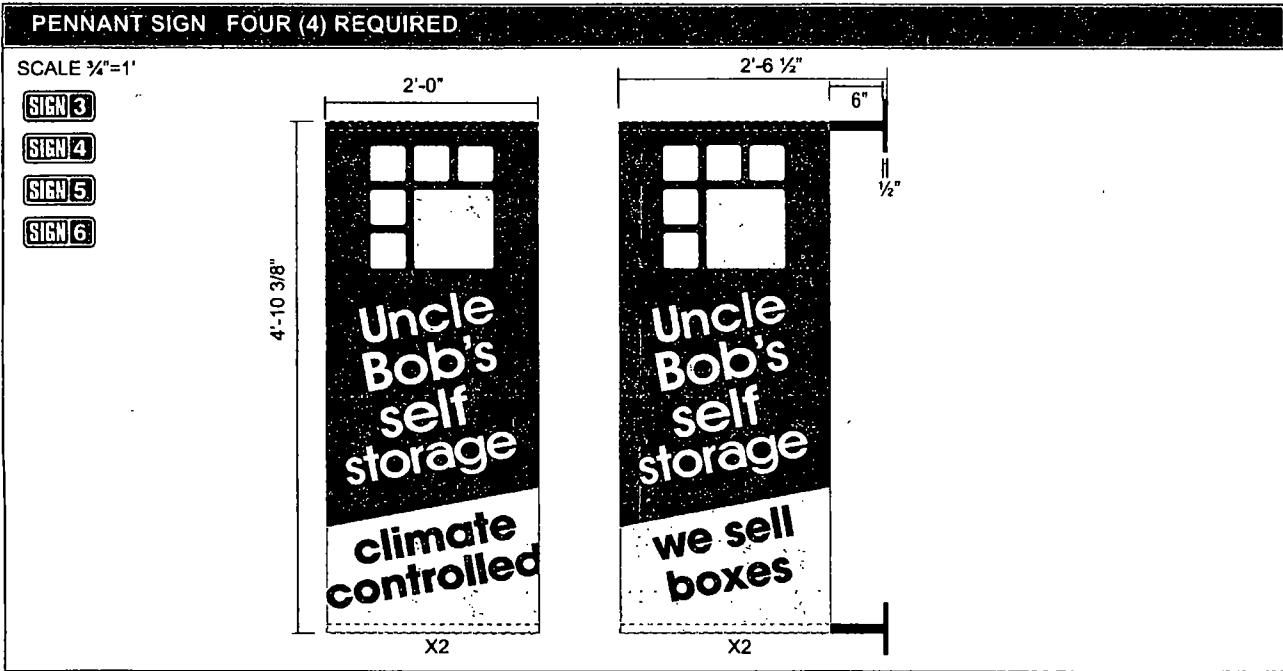

SPECIFICATIONS

- HEMMED POCKETS TOP & BOTTOM
- DOUBLE FACE BANNERS (3M PANAFLEX 945 SERIES MATERIAL WITH 3M VINYL OVERLAY APPLIED FIRST SURFACE)
- STEEL FLAG MOUNTED POLES
- INSTALLATION STEEL PLATE WITH NUTS, BOLTS, & WASHERS AS REQUIRED (DESIGN MAY VARY)

COLOR SCHEDULE

PMS 293 C
BLUE COLORKOTE 2870
3630-157 SULTAN BLUE VINYL

WHITE
YELLOW 3630-025 VINYL
BLACK

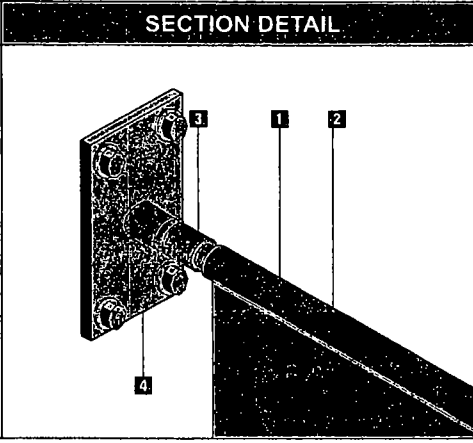

SIGNS

Houston
Dallas

Houston Corporate Office
5225 Katy Freeway, Suite 350
Houston, Texas 77007
713-977-7900
Fax: 713-977-7903

Dallas Regional Office
2220 San Jacinto Blvd.
Suite 365
Denton, Texas 76205
940-380-9153
FAX: 940-380-9395

Uncle Bob's self storage

Address #832
1601 S. Ashland Ave.
Chicago, IL 60608
State: IL 60608
Account Rep: B.OSBORN
Sales Rep: M.J.DeNARDO

APPROVALS
CLIENT _____
DESIGN _____
PROD. _____

Designer: PETER CARDINAL/EIT
Design No. Us163028 R11
DATE 12-17-13
Rev. Date. 3-6-14

7:15

The purchaser agrees to hold the seller harmless against any cause for action for damage which may occur as a result of failure to alert for other one time purchasers, including but not limited to sewer, gas lines or any underground obstacles which the purchaser or others may deem reliable.



05/28/2014

Alderman **Daniel S. Solis**
Ward # **25**
City of Chicago
City Hall, Room **203**
121 North LaSalle Street
Chicago, Illinois 60602

Re: An ordinance to use and maintain a portion of the public right-of-way for **four (4) banner(s)** for **UNCLE BOB'S STORAGE**, adjacent to the premises known as **1601-25 S. Ashland Ave.**.

Dear Alderman **Daniel S. Solis**:

The applicant referenced above has requested the use of the public right-of-way for a **banner(s)**. An ordinance has been prepared by the Department of Business Affairs and Consumer Protection – Small Business Center - Public Way Use Unit for presentation to the City Council. Because this request was made for properties located in your ward, as approved by you as per the attached, I respectfully request that you introduce the attached ordinance at the next City Council meeting.

If you have any questions regarding this ordinance, please contact Anthony Bertuca at (312) 744-5506.

Department of Business Affairs and Consumer Protection



City of Chicago



O2014-4766

Office of the City Clerk Document Tracking Sheet

| | |
|---------------------------------|---|
| Meeting Date: | 5/28/2014 |
| Sponsor(s): | Solis (25) |
| Type: | Ordinance |
| Title: | Grant(s) of privilege in public way for Uncle Bob's Storage - signs |
| Committee(s) Assignment: | Committee on Transportation and Public Way |

ORDINANCE
UNCLE BOB'S STORAGE
Acct. No. 387869 - 1
Permit No. 1111738

Be It Ordained by the City Council of the City of Chicago:

SECTION 1. Permission and authority are hereby given and granted to UNCLE BOB'S STORAGE, upon the terms and subject to the conditions of this ordinance to maintain and use five (5) sign(s) projecting over the public right-of-way attached to its premises known as 1601-25 S. Ashland Ave..

Said sign structure(s) measures as follows; along S Ashland Ave:

One (1) at fifty (50) feet in length, three point six seven (3.67) feet in height and thirteen (13) feet above grade level.

One (1) at four point two five (4.25) feet in length, twelve (12) feet in height and fourteen (14) feet above grade level.

Said sign structure(s) measures as follows; along W 17th St:

One (1) at three (3) feet in length, one point five (1.5) feet in height and sixteen (16) feet above grade level.

One (1) at eight point five eight (8.58) feet in length, three (3) feet in height and sixteen (16) feet above grade level.

Said sign structure(s) measures as follows; along W. 16th St:

One (1) at eight point five eight (8.58) feet in length, three (3) feet in height and sixteen (16) feet above grade level.

The location of said privilege shall be as shown on prints kept on file with the Department of Business Affairs and Consumer Protection and the Office of the City Clerk.

Said privilege shall be constructed in accordance with plans and specifications approved by the Department of Transportation (Division of Project Development) and Zoning Department - Signs.

This grant of privilege in the public way shall be subject to the provisions of Section 10-28-015 and all other required provisions of the Municipal Code of Chicago.

The grantee shall pay to the City of Chicago as compensation for the privilege #1111738 herein granted the sum of one thousand three hundred (\$1,300.00) per annum in advance.

A 25% penalty will be added for payments received after due date.

The permit holder agrees to hold the City of Chicago harmless for any damage, relocation or replacement costs associated with damage, relocation or removal of private property caused by the City performing work in the public way.

Authority herein given and granted for a period of five (5) years from and after Date of Passage.

Alderman

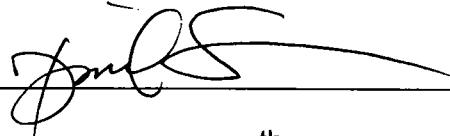
A handwritten signature in black ink, appearing to read 'Solis', written over a horizontal line.

Daniel S. Solis 25th Ward

LED FACE LIT RACEWAY MOUNTED CHANNEL LETTER SET HORIZONTAL (BLUE) SIX PIECE LOGO

SIGN 2

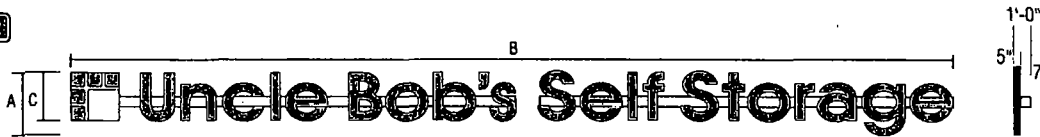

weight = 450-500 lbs

| NAME | A | B | C | SQ/FT |
|------------------|-------|--------|-----------|-------|
| UB-HZ-BL-RWCL-50 | 3'-8" | 50'-0" | 2'-9 1/4" | 185 |

EXPLODED DETAIL



SPECIFICATIONS

- 11 NON-CORROSIVE INSTALLATION HARDWARE: SEE DETAIL
- 21 5" FABRICATED ALUMINUM LETTER RETURNS PAINTED BLACK PAINT INTERIOR WITH LIGHT ENHANCING PAINT (LOGO TO BE 6 SEPARATE CHANNELS ON ALUMINUM BACK PANEL PAINTED TO MATCH FASCIA)
- 31 1" BLACK TRIM CAP
- 24 FLAT ALUMINUM BACK WELDED TO RETURNS
- 15 1/2" THICK METAL FLAT BAR FOR A SECURE INSTALLATION
- 16 LED DIODE MODULE WHITE
- 17 3/16" THICK PLEX FACE WHITE WITH 1ST SURFACE VINYL
- 18 LOW VOLTAGE ELECTRONIC TRANSFORMER MOUNTED IN A 7 1/4" X 7 1/4" EXTRUDED .050 ALUM. RACEWAY SUPPORT/WIRING BOX PAINTED TO MATCH FASCIA
- 19 VISIBLE CUT-OFF SWITCH WITH FLIP-UP COVER
- 10 1/4" WEEP HOLES (2) TWO PER LETTER
- 14 GROUNDED WALL PASS-THRU SEALED WATER TIGHT

SIDE SECTION VIEW

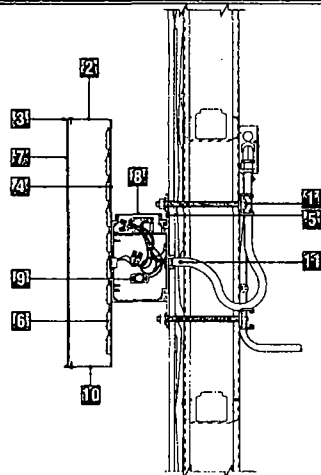

MOUNTING DETAIL

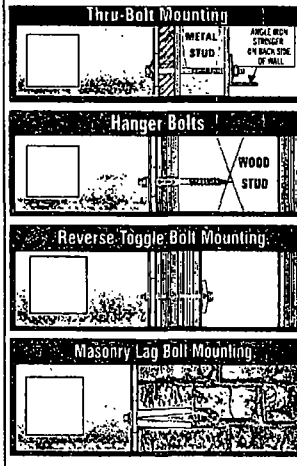

COLOR SCHEDULE

- PMS 293 C
BLUE COLORKOTE 2870
3630-157 SULTAN BLUE VINYL
- YELLOW 3630-025 VINYL
- WHITE
- BLACK



Houston
Dallas

Houston Corporate Office
5225 Katy Freeway, Suite 350
Houston, Texas 77007
713-977-7900
Fax 713-977-7903

Dallas Regional Office
2220 San Jacinto Blvd.
Suite 365
Denton, Texas 76205
940-380-9133
FAX 940-380-9395

Uncle Bob's self storage

Address: #832
1601 S. Ashland Ave.
Chicago, IL 60608

State: Account Rep: B.OSBORN
Sales Rep: M.J.DeNARDO

APPROVALS
CLIENT _____
DESIGN _____
PROD. _____

Designer: PETER CARDINAL/EIT
Design No. Us163028 R11

DATE 12-17-13

Rev. Date: 3-6-14

5:15

The purchaser agrees to hold the seller harmless against any cause for action for damage which may occur as a result of shipping for price and conditions, including but not limited to, weight loss or any underrun of stock which the purchaser or others may agree valuable



05/28/2014

Alderman **Daniel S. Solis**
Ward # **25**
City of Chicago
City Hall, Room **203**
121 North LaSalle Street
Chicago, Illinois 60602

Re: An ordinance to use and maintain a portion of the public right-of-way for **five (5) sign(s)** for **UNCLE BOB'S STORAGE**, adjacent to the premises known as **1601-25 S. Ashland Ave.**.

Dear Alderman **Daniel S. Solis**:

The applicant referenced above has requested the use of the public right-of-way for a **sign(s)**. An ordinance has been prepared by the Department of Business Affairs and Consumer Protection – Small Business Center - Public Way Use Unit for presentation to the City Council. Because this request was made for properties located in your ward, as approved by you as per the attached, I respectfully request that you introduce the attached ordinance at the next City Council meeting.

If you have any questions regarding this ordinance, please contact Anthony Bertuca at (312) 744-5506.

Department of Business Affairs and Consumer Protection



City of Chicago



O2014-4769

Office of the City Clerk

Document Tracking Sheet

| | |
|---------------------------------|---|
| Meeting Date: | 5/28/2014 |
| Sponsor(s): | Maldonado (26) |
| Type: | Ordinance |
| Title: | Grant(s) of privilege in public way for La Canasta Bakery, Inc. |
| Committee(s) Assignment: | Committee on Transportation and Public Way |

ORDINANCE
LA CANASTA BAKERY, INC.
Acct. No. 324506 - 1
Permit No. 1110816

Be It Ordained by the City Council of the City of Chicago:

SECTION 1. Permission and authority are hereby given and granted to LA CANASTA BAKERY, INC., upon the terms and subject to the conditions of this ordinance to maintain and use, as now constructed, three (3) Fire Shutter(s) projecting over the public right-of-way adjacent to its premises known as 3575 W. Armitage Ave..

Said Fire Shutter(s) at W Armitage Ave measure(s):

One (1) at three point seven five (3.75) feet in length, and point three three (.33) feet in width for a total of one point two four (1.24) square feet.

Two (2) at eight point five eight (8.58) feet in length, and point three three (.33) feet in width for a total of five point six six (5.66) square feet.

The location of said privilege shall be as shown on prints kept on file with the Department of Business Affairs and Consumer Protection and the Office of the City Clerk.

Said privilege shall be constructed in accordance with plans and specifications approved by the Department of Transportation (Division of Project Development).

This grant of privilege in the public way shall be subject to the provisions of Section 10-28-015 and all other required provisions of the Municipal Code of Chicago.

The grantee shall pay to the City of Chicago as compensation for the privilege #1110816 herein granted the sum of one thousand two hundred (\$1,200.00) per annum in advance.

A 25% penalty will be added for payments received after due date.

The permit holder agrees to hold the City of Chicago harmless for any damage, relocation or replacement costs associated with damage, relocation or removal of private property caused by the City performing work in the public way.

Authority herein given and granted for a period of five (5) years from and after 01/13/2014.

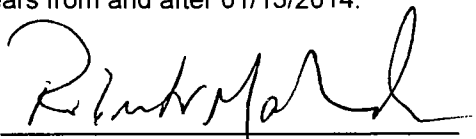
Alderman 

Roberto Maldonado 26th Ward

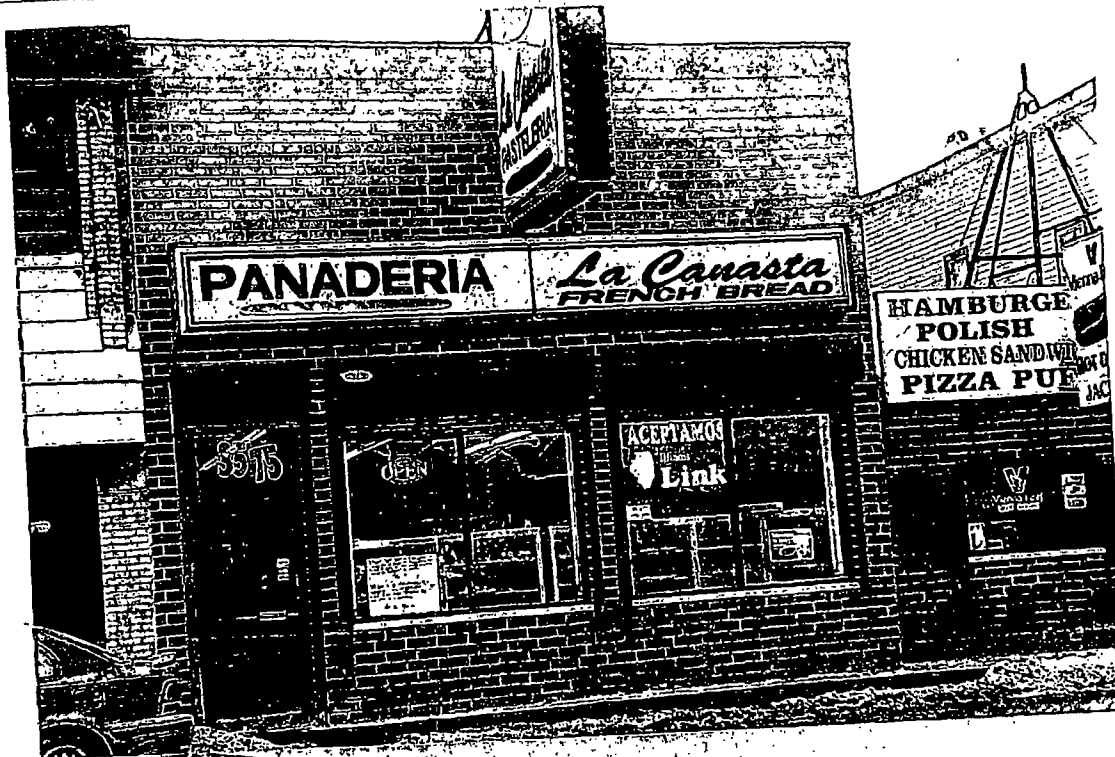



2nd ATTEMPT AT INTRODUCTION

05/28/2014

Alderman **Roberto Maldonado**
Ward # 26
City of Chicago
City Hall, Room 300
121 North LaSalle Street
Chicago, Illinois 60602

Re: An ordinance to use and maintain a portion of the public right-of-way for **three (3) fire shutter(s)** for **LA CANASTA BAKERY, INC.**, adjacent to the premises known as **3575 W. Armitage Ave.**.

Dear Alderman **Roberto Maldonado**:

The applicant referenced above has requested the use of the public right-of-way for a **fire shutter(s)**. An ordinance has been prepared by the Department of Business Affairs and Consumer Protection – Small Business Center - Public Way Use Unit for presentation to the City Council. Because this request was made for properties located in your ward, as approved by you as per the attached, I respectfully request that you introduce the attached ordinance at the next City Council meeting.

If you have any questions regarding this ordinance, please contact Anthony Bertuca at (312) 744-5506.

Department of Business Affairs and Consumer Protection



City of Chicago



O2014-4289

Office of the City Clerk

Document Tracking Sheet

| | |
|---------------------------------|--|
| Meeting Date: | 5/28/2014 |
| Sponsor(s): | Burnett (27) |
| Type: | Ordinance |
| Title: | Grant(s) of privilege in public way for Bert's Car Wash & Detail Center |
| Committee(s) Assignment: | Committee on Transportation and Public Way |

ORDINANCE
BERT'S CAR WASH & DETAIL CENTER
Acct. No. 288518 - 1
Permit No. 1113036

Be It Ordained by the City Council of the City of Chicago:

SECTION 1. Permission and authority are hereby given and granted to BERT'S CAR WASH & DETAIL CENTER, upon the terms and subject to the conditions of this ordinance to maintain and use four (4) sign(s) projecting over the public right-of-way attached to its premises known as 461 N. Elizabeth St..

Said sign structure(s) measures as follows; along ELIZABETH ST.:

One (1) at thirteen (13) feet in length, two point three three (2.33) feet in height and sixteen (16) feet above grade level.

Said sign structure(s) measures as follows; along N. ELIZABETH ST.:

One (1) at nineteen (19) feet in length, seven point six seven (7.67) feet in height and twelve (12) feet above grade level.

Said sign structure(s) measures as follows; along ELIZABETH ST.:

One (1) at fifteen (15) feet in length, four (4) feet in height and fourteen (14) feet above grade level.

Said sign structure(s) measures as follows; along GRAND AVE.:

One (1) at twelve (12) feet in length, twenty-two (22) feet in height and twelve (12) feet above grade level.

The location of said privilege shall be as shown on prints kept on file with the Department of Business Affairs and Consumer Protection and the Office of the City Clerk.

Said privilege shall be constructed in accordance with plans and specifications approved by the Department of Transportation (Division of Project Development) and Zoning Department - Signs.

This grant of privilege in the public way shall be subject to the provisions of Section 10-28-015 and all other required provisions of the Municipal Code of Chicago.

The grantee shall pay to the City of Chicago as compensation for the privilege #1113036 herein granted the sum of one thousand two hundred (\$1,200.00) per annum in advance.

A 25% penalty will be added for payments received after due date.

The permit holder agrees to hold the City of Chicago harmless for any damage, relocation or replacement costs associated with damage, relocation or removal of private property caused by the City performing work in the public way.

Authority herein given and granted for a period of five (5) years from and after 05/13/2014.

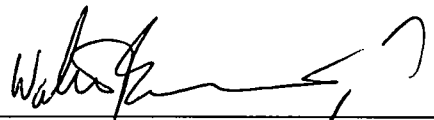
Alderman 
Walter Burnett Jr. 27th Ward

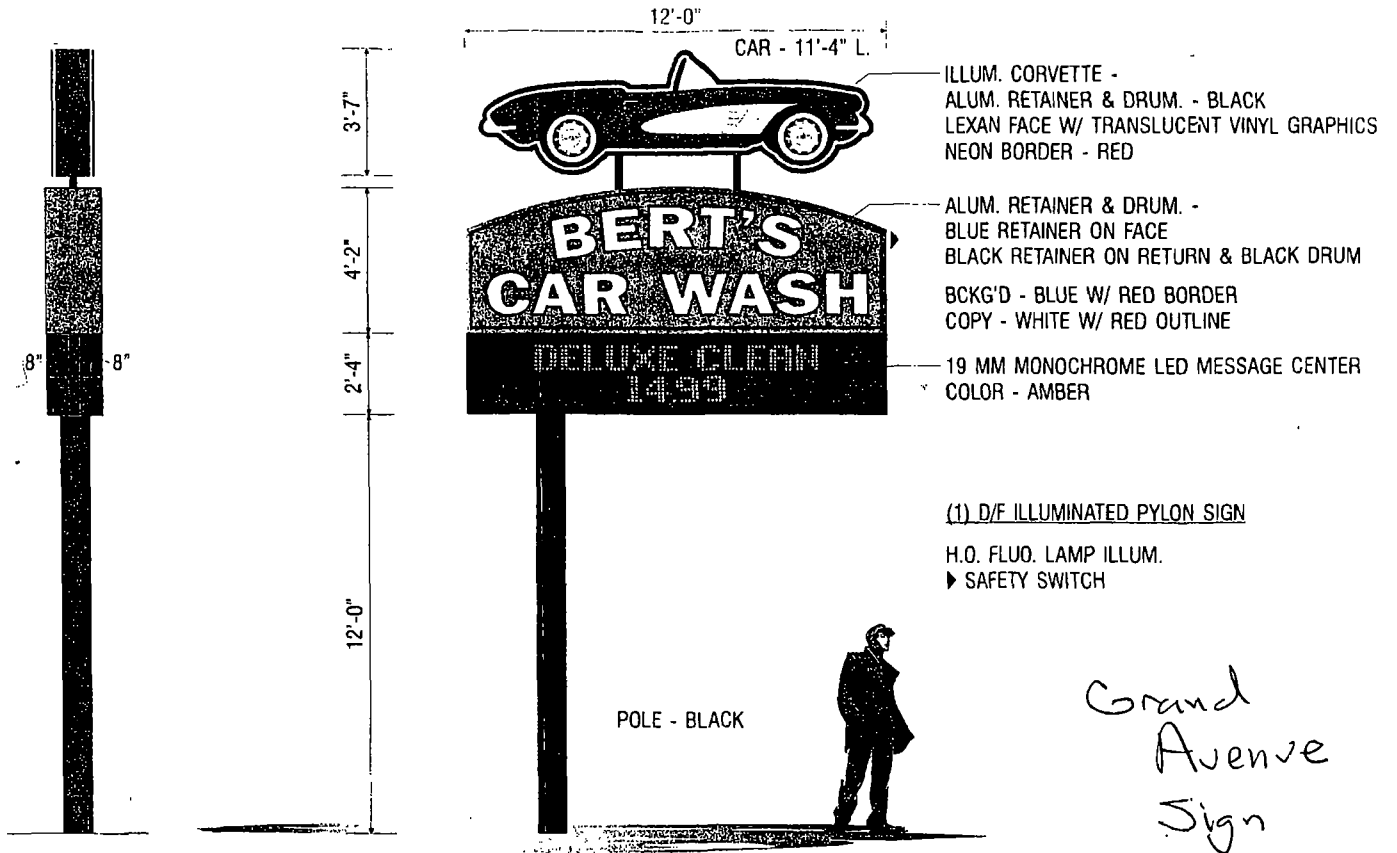

APPROVED: _____ DATE: _____

| <p>M-K SIGNS CHICAGO</p> <p>4900 N. ELSTON AVE CHICAGO, IL 60630 TEL: 773-477-7777 FAX: 773-477-0047 E-MAIL: oridept@mksgns.net</p> | <p>BERT'S CAR WASH 1231 W. GRAND AVE. CHICAGO, IL</p> <p>Colors represented in this drawing are for presentation purposes only They will not match your finished product exactly. Actual color samples can be obtained from your sales representative.</p> <p>This design is the original and unpublished work of M-K SIGNS and may not be reproduced, copied or exhibited in any fashion without the expressed written consent of M-K SIGNS. The rights to this design may be purchased.</p> | <table border="1"> <thead> <tr> <th>DATE</th> <th>REVISION</th> </tr> </thead> <tbody> <tr> <td>5-9-08</td> <td></td> </tr> <tr> <td>10-22-08</td> <td></td> </tr> <tr> <td></td> <td></td> </tr> <tr> <td></td> <td></td> </tr> <tr> <td></td> <td></td> </tr> <tr> <td></td> <td></td> </tr> </tbody> </table> | DATE | REVISION | 5-9-08 | | 10-22-08 | | | | | | | | | | <table border="1"> <tr> <td>SCALE</td> <td>DATE</td> </tr> <tr> <td>1/4"=1'-0"</td> <td>4-10-08</td> </tr> <tr> <td>DESIGNER</td> <td>SALES</td> </tr> <tr> <td>LM</td> <td>RC</td> </tr> <tr> <td>FILE</td> <td>DRAWING NUMBER</td> </tr> <tr> <td>Bert's Car Wash</td> <td>9265</td> </tr> </table> | SCALE | DATE | 1/4"=1'-0" | 4-10-08 | DESIGNER | SALES | LM | RC | FILE | DRAWING NUMBER | Bert's Car Wash | 9265 |
|--|--|--|----------|----------|--------|--|----------|--|--|--|--|--|--|--|--|--|---|-------|------|------------|---------|----------|-------|----|----|------|----------------|-----------------|------|
| | | DATE | REVISION | | | | | | | | | | | | | | | | | | | | | | | | | | |
| 5-9-08 | | | | | | | | | | | | | | | | | | | | | | | | | | | | | |
| 10-22-08 | | | | | | | | | | | | | | | | | | | | | | | | | | | | | |
| | | | | | | | | | | | | | | | | | | | | | | | | | | | | | |
| | | | | | | | | | | | | | | | | | | | | | | | | | | | | | |
| | | | | | | | | | | | | | | | | | | | | | | | | | | | | | |
| | | | | | | | | | | | | | | | | | | | | | | | | | | | | | |
| SCALE | DATE | | | | | | | | | | | | | | | | | | | | | | | | | | | | |
| 1/4"=1'-0" | 4-10-08 | | | | | | | | | | | | | | | | | | | | | | | | | | | | |
| DESIGNER | SALES | | | | | | | | | | | | | | | | | | | | | | | | | | | | |
| LM | RC | | | | | | | | | | | | | | | | | | | | | | | | | | | | |
| FILE | DRAWING NUMBER | | | | | | | | | | | | | | | | | | | | | | | | | | | | |
| Bert's Car Wash | 9265 | | | | | | | | | | | | | | | | | | | | | | | | | | | | |



City of Chicago



O2014-4294

Office of the City Clerk

Document Tracking Sheet

| | |
|---------------------------------|---|
| Meeting Date: | 5/28/2014 |
| Sponsor(s): | Burnett (27) |
| Type: | Ordinance |
| Title: | Grant(s) of privilege in public way for Chicago Park District - landscapings |
| Committee(s) Assignment: | Committee on Transportation and Public Way |

ORDINANCE
CHICAGO PARK DISTRICT
Acct. No. 17339 - 52
Permit No. 1112428

Be It Ordained by the City Council of the City of Chicago:

SECTION 1. Permission and authority are hereby given and granted to CHICAGO PARK DISTRICT, upon the terms and subject to the conditions of this ordinance to maintain and use, as now constructed, eight (8) Landscaping(s) on the public right-of-way for beautification purposes adjacent to its premises known as 412 W. Chicago Ave..

Said Landscaping(s) at N. Sedgwick Street measure(s):

Four (4) at fifty-five (55) feet in length, and six (6) feet in width for a total of one thousand three hundred twenty (1320) square feet.

Said Landscaping(s) at N. Hudson Street measure(s):

Four (4) at forty-five (45) feet in length, and six (6) feet in width for a total of one thousand eighty (1080) square feet.

The location of said privilege shall be as shown on prints kept on file with the Department of Business Affairs and Consumer Protection and the Office of the City Clerk.

Said privilege shall be constructed in accordance with plans and specifications approved by the Department of Planning and Development and Department of Transportation (Division of Project Development).

This grant of privilege in the public way shall be subject to the provisions of Section 10-28-015 and all other required provisions of the Municipal Code of Chicago.

The grantee shall pay to the City of Chicago as compensation for the privilege #1112428 herein granted the sum of zero (\$.00) per annum in advance.

A 25% penalty will be added for payments received after due date.

The permit holder agrees to hold the City of Chicago harmless for any damage, relocation or replacement costs associated with damage, relocation or removal of private property caused by the City performing work in the public way.

Authority herein given and granted for a period of five (5) years from and after Date of Passage.

Alderman

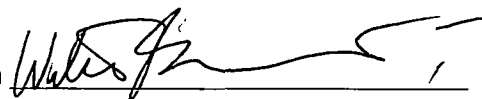

Walter Burnett Jr. 27th Ward

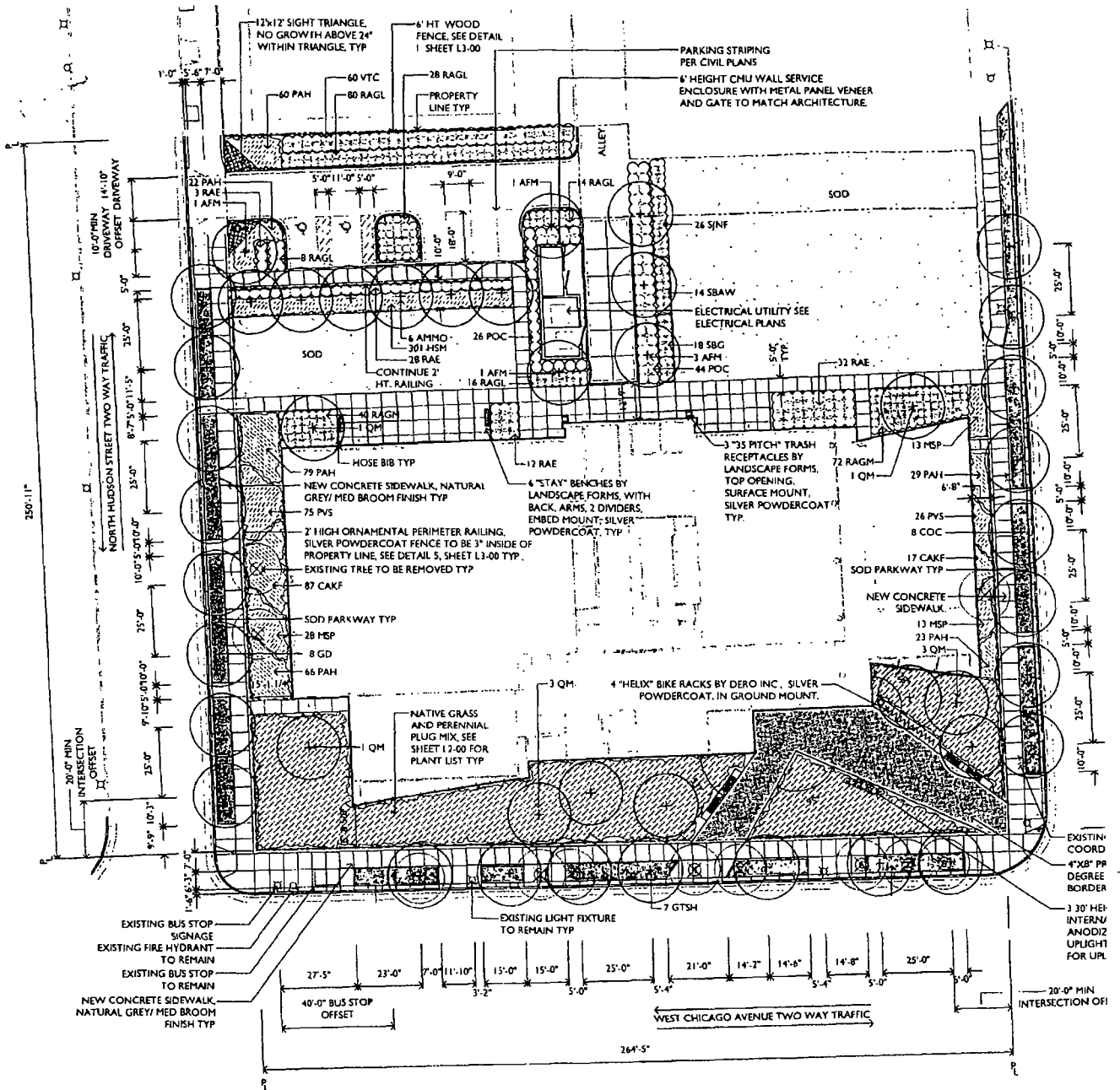

1 SITE AND LANDSCAPE PLAN
SCALE 1"=20'-0"

EXISTING TREE KEY

| NUMBER | SIZE | SPECIES | CONDITION | REMARKS |
|--------|------|---------|-----------|---------------|
| 1 | 4" | ASH | FAIR | TO BE REMOVED |
| 2 | 9" | ELM | GOOD | TO BE REMOVED |
| 3 | 4" | ASH | FAIR | TO BE REMOVED |
| 4 | 5" | ASH | FAIR | TO BE REMOVED |
| 5 | 6" | LOCUST | FAIR | TO BE REMOVED |
| 6 | 4" | LOCUST | POOR | TO BE REMOVED |
| 7 | 4" | LOCUST | FAIR | TO BE REMOVED |
| 8 | 2" | GINKGO | FAIR | TO BE REMOVED |



TREE NO. 1



TREE NO. 2



TREE NO. 3



TREE NO. 4



TREE NO. 5



TREE NO. 6



TREE NO. 7



City of Chicago



O2014-4302

Office of the City Clerk

Document Tracking Sheet

| | |
|---------------------------------|---|
| Meeting Date: | 5/28/2014 |
| Sponsor(s): | Burnett (27) |
| Type: | Ordinance |
| Title: | Grant(s) of privilege in public way for Chicago Park District - planter railings |
| Committee(s) Assignment: | Committee on Transportation and Public Way |

ORDINANCE
CHICAGO PARK DISTRICT
Acct. No. 17339 - 52
Permit No. 1112431

Be It Ordained by the City Council of the City of Chicago:

SECTION 1. Permission and authority are hereby given and granted to CHICAGO PARK DISTRICT, upon the terms and subject to the conditions of this ordinance to maintain and use, as now constructed, five (5) Planter Railling(s) on the public right-of-way for beautification purposes adjacent to its premises known as 412 W. Chicago Ave..

Said Planter Railling(s) at W. Chicago Avenue measure(s):
Five (5) at thirty (30) feet in length, and six (6) feet in width for a total of nine hundred (900) square feet.

Grantee must allow the required clear and unobstructed space for pedestrian passage at all times per rules and regulations approved by the Department of Transportation.

The location of said privilege shall be as shown on prints kept on file with the Department of Business Affairs and Consumer Protection and the Office of the City Clerk.

Said privilege shall be constructed in accordance with plans and specifications approved by the Department of Planning and Development and Department of Transportation (Division of Project Development).

This grant of privilege in the public way shall be subject to the provisions of Section 10-28-015 and all other required provisions of the Municipal Code of Chicago.

The grantee shall pay to the City of Chicago as compensation for the privilege #1112431 herein granted the sum of zero (\$.00) per annum in advance.

A 25% penalty will be added for payments received after due date.

The permit holder agrees to hold the City of Chicago harmless for any damage, relocation or replacement costs associated with damage, relocation or removal of private property caused by the City performing work in the public way.

Authority herein given and granted for a period of five (5) years from and after Date of Passage.

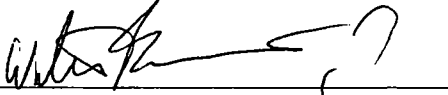
Alderman 

Walter Burnett Jr. 27th Ward

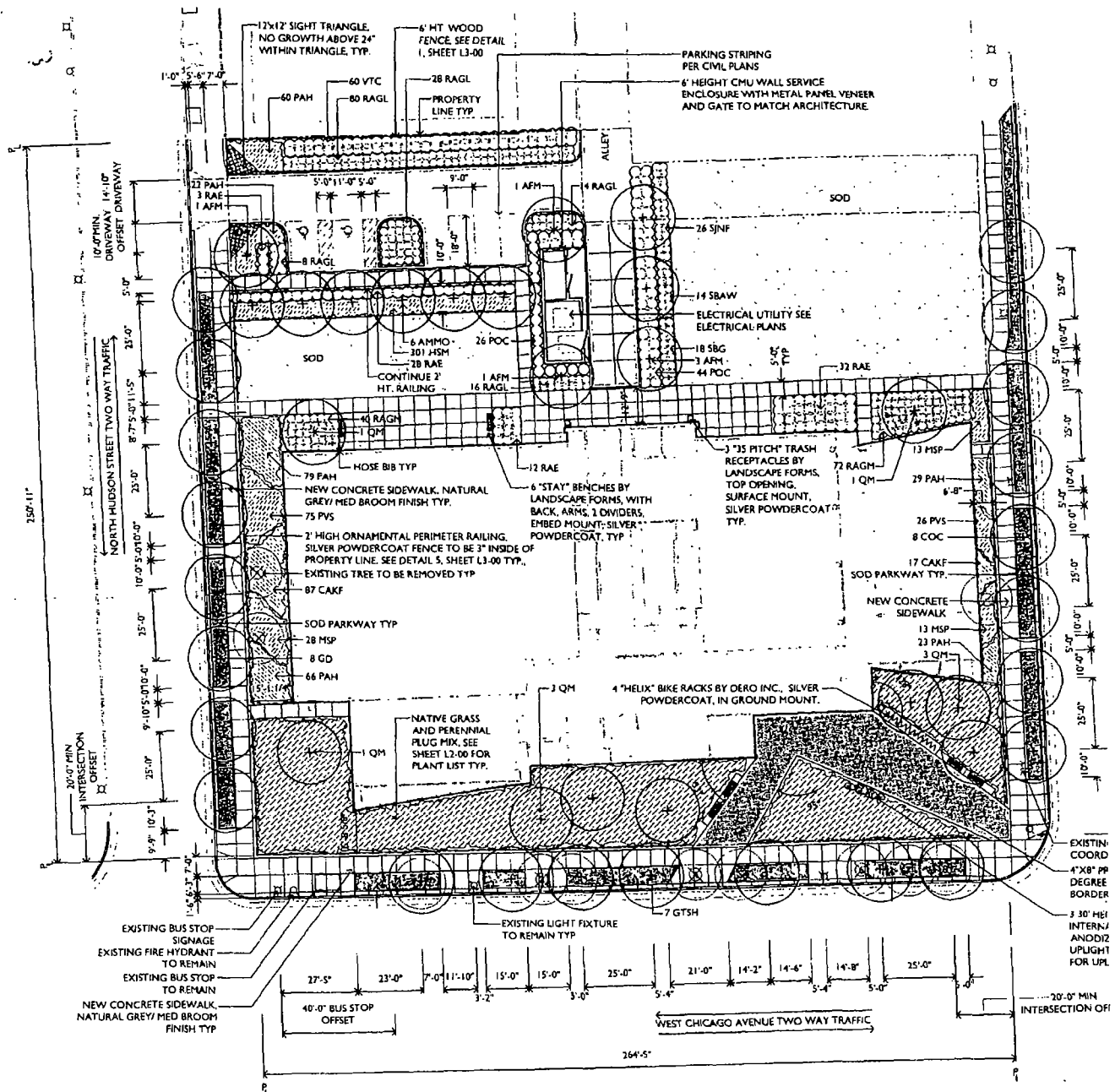

1 SITE AND LANDSCAPE PLAN
SCALE 1"=20'-0"

EXISTING TREE KEY

| NUMBER | SIZE | SPECIES | CONDITION | REMARKS |
|--------|------|---------|-----------|---------------|
| 1 | 4" | ASH | FAIR | TO BE REMOVED |
| 2 | 9" | ELM | GOOD | TO BE REMOVED |
| 3 | 4" | ASH | FAIR | TO BE REMOVED |
| 4 | 5" | ASH | FAIR | TO BE REMOVED |
| 5 | 6" | LOCLUST | FAIR | TO BE REMOVED |
| 6 | 4" | LOCLUST | POOR | TO BE REMOVED |
| 7 | 4" | LOCLUST | FAIR | TO BE REMOVED |
| 8 | 2" | GINKGO | FAIR | TO BE REMOVED |



TREE NO 1

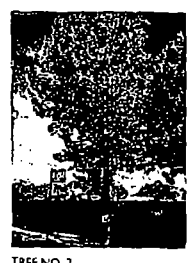

TREE NO 2



TREE NO 3



TREE NO 4



TREE NO 5



TREE NO 6



TREE NO 7



City of Chicago



O2014-4308

Office of the City Clerk

Document Tracking Sheet

| | |
|---------------------------------|---|
| Meeting Date: | 5/28/2014 |
| Sponsor(s): | Burnett (27) |
| Type: | Ordinance |
| Title: | Grant(s) of privilege in public way for Chicago Park District - trees |
| Committee(s) Assignment: | Committee on Transportation and Public Way |

ORDINANCE
CHICAGO PARK DISTRICT
Acct. No. 17339 - 52
Permit No. 1112427

Be It Ordained by the City Council of the City of Chicago:

SECTION 1. Permission and authority are hereby given and granted to CHICAGO PARK DISTRICT, upon the terms and subject to the conditions of this ordinance to maintain and use, as now constructed, twenty-three (23) Trees(s) on the public right-of-way for beautification purposes adjacent to its premises known as 412 W. Chicago Ave..

Said Trees(s) at N. Hudson Street measure(s):

Eight (8) at one (1) foot in length, and point five (.5) feet in width for a total of four (4) square feet.

Said Trees(s) at N. Sedgwick Street measure(s):

Eight (8) at one (1) foot in length, and point five (.5) feet in width for a total of four (4) square feet.

Said Trees(s) at W. Chicago Avenue measure(s):

Seven (7) at one (1) foot in length, and point five (.5) feet in width for a total of three point five (3.5) square feet.

The location of said privilege shall be as shown on prints kept on file with the Department of Business Affairs and Consumer Protection and the Office of the City Clerk.

Said privilege shall be constructed in accordance with plans and specifications approved by the Department of Planning and Development and Department of Transportation (Division of Project Development).

This grant of privilege in the public way shall be subject to the provisions of Section 10-28-015 and all other required provisions of the Municipal Code of Chicago.

The grantee shall pay to the City of Chicago as compensation for the privilege #1112427 herein granted the sum of zero (\$.00) per annum in advance.

A 25% penalty will be added for payments received after due date.

The permit holder agrees to hold the City of Chicago harmless for any damage, relocation or replacement costs associated with damage, relocation or removal of private property caused by the City performing work in the public way.

Authority herein given and granted for a period of five (5) years from and after Date of Passage.

Alderman

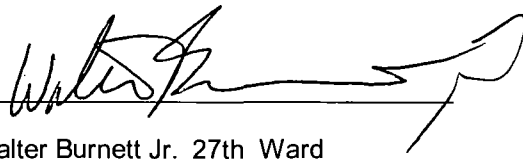

Walter Burnett Jr. 27th Ward

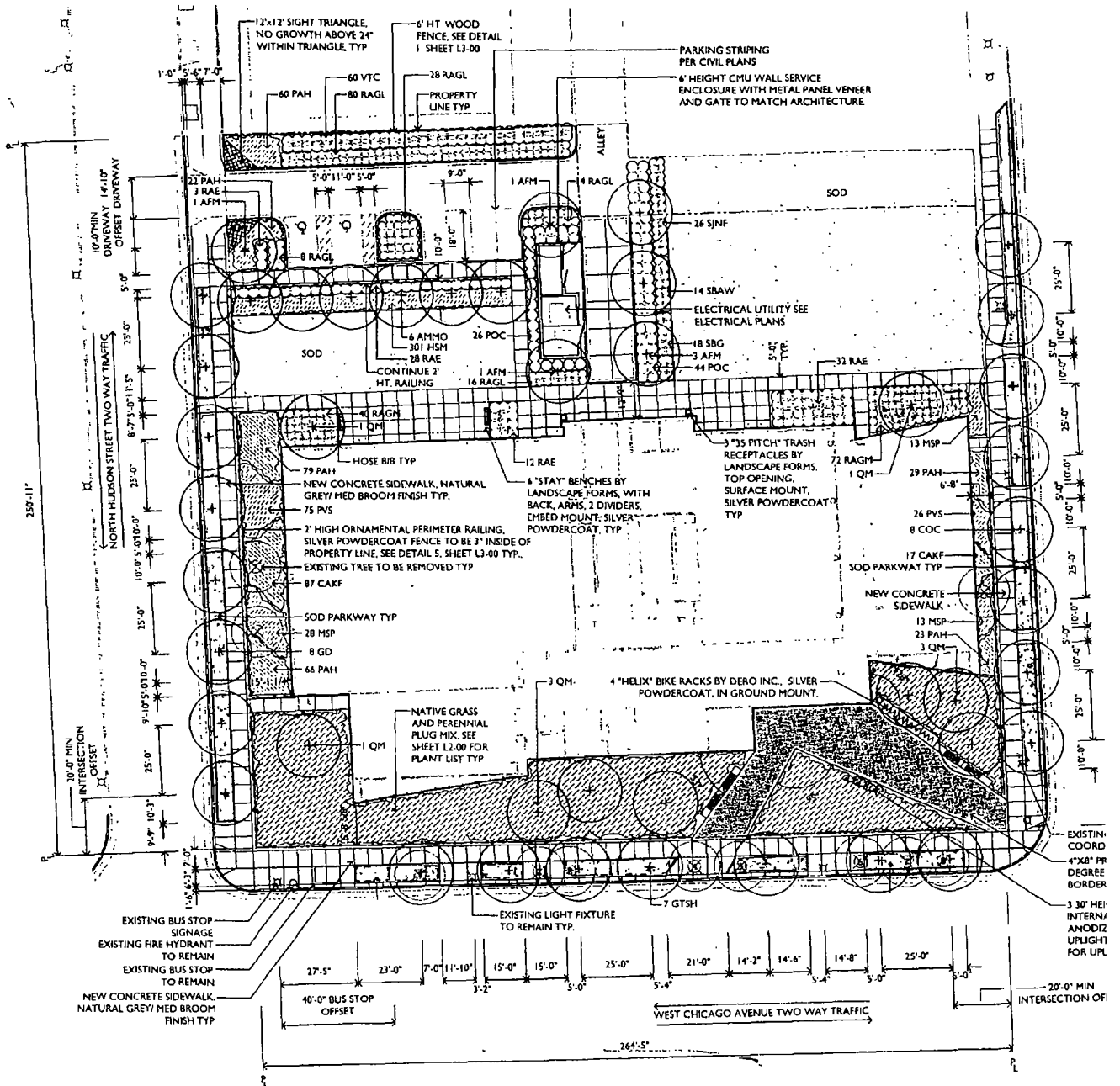

1 SITE AND LANDSCAPE PLAN
SCALE: 1"=20'-0"

EXISTING TREE KEY

| NUMBER | SIZE | SPECIES | CONDITION | REMARKS |
|--------|------|---------|-----------|---------------|
| 1 | 4" | ASH | FAIR | TO BE REMOVED |
| 2 | 9" | ELM | GOOD | TO BE REMOVED |
| 3 | 4" | ASH | FAIR | TO BE REMOVED |
| 4 | 5" | ASH | FAIR | TO BE REMOVED |
| 5 | 6" | LOCUST | FAIR | TO BE REMOVED |
| 6 | 4" | LOCUST | POOR | TO BE REMOVED |
| 7 | 4" | LOCUST | FAIR | TO BE REMOVED |
| 8 | 2" | GINKGO | FAIR | TO BE REMOVED |



TREE NO. 1

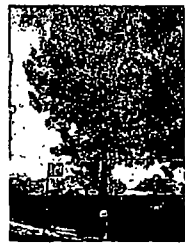

TREE NO. 2



TREE NO. 3



TREE NO. 4



TREE NO. 5



TREE NO. 6



TREE NO. 7



City of Chicago



O2014-4313

Office of the City Clerk

Document Tracking Sheet

| | |
|---------------------------------|---|
| Meeting Date: | 5/28/2014 |
| Sponsor(s): | Burnett (27) |
| Type: | Ordinance |
| Title: | Grant(s) of privilege in public way for De Cero |
| Committee(s) Assignment: | Committee on Transportation and Public Way |

ORDINANCE
DE CERO
Acct. No. 273771 - 1
Permit No. 1111589

Be It Ordained by the City Council of the City of Chicago:

SECTION 1. Permission and authority are hereby given and granted to DE CERO, upon the terms and subject to the conditions of this ordinance to maintain and use, as now constructed, one (1) Wind Screen(s) on the public right-of-way adjacent to its premises known as 812-816 W. Randolph St..

Said Wind Screen(s) at W Randolph St measure(s):
One (1) at eight (8) feet in length, and five (5) feet in width for a total of forty (40) square feet.

The location of said privilege shall be as shown on prints kept on file with the Department of Business Affairs and Consumer Protection and the Office of the City Clerk.

Said privilege shall be constructed in accordance with plans and specifications approved by the Department of Transportation (Division of Project Development).

This grant of privilege in the public way shall be subject to the provisions of Section 10-28-015 and all other required provisions of the Municipal Code of Chicago.

The grantee shall pay to the City of Chicago as compensation for the privilege #1111589 herein granted the sum of four hundred (\$400.00) per annum in advance.

A 25% penalty will be added for payments received after due date.

The permit holder agrees to hold the City of Chicago harmless for any damage, relocation or replacement costs associated with damage, relocation or removal of private property caused by the City performing work in the public way.

Authority herein given and granted for a period of five (5) years from and after Date of Passage.

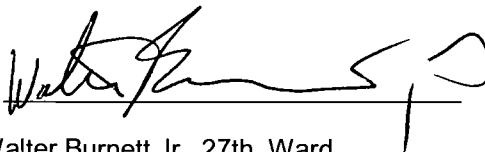
Alderman 
Walter Burnett Jr. 27th Ward

Tdqueria L.P
d/b/a. de ceco 812-814 W. Randolph
street

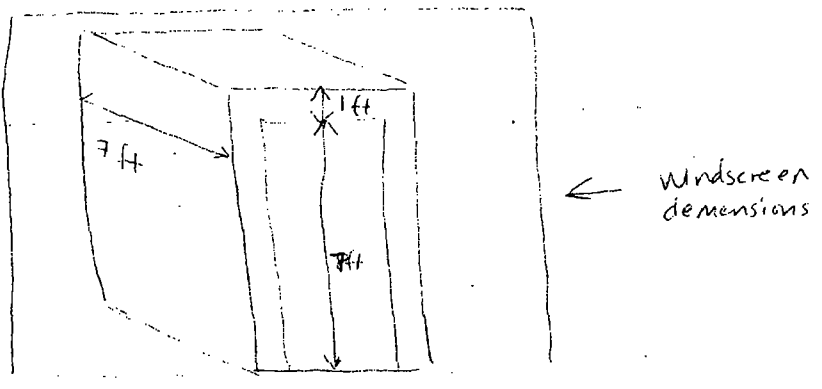
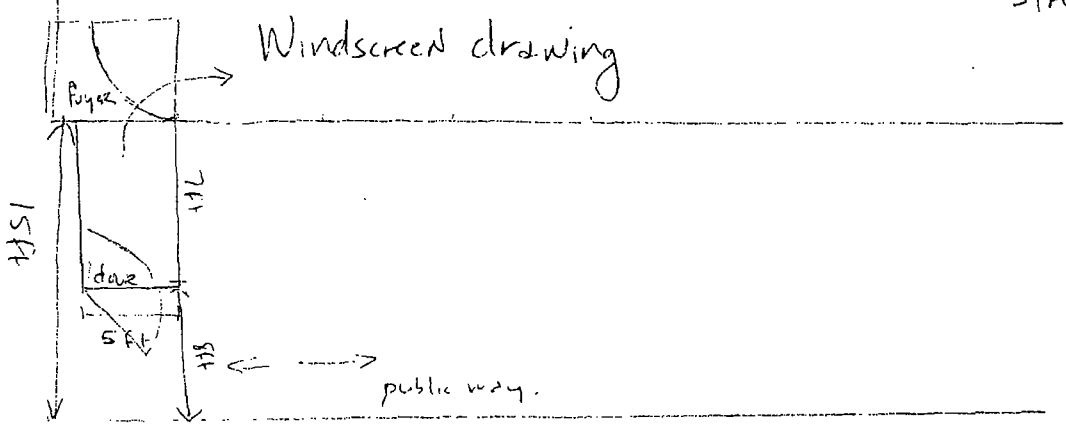



City of Chicago



O2014-4315

Office of the City Clerk

Document Tracking Sheet

| | |
|---------------------------------|---|
| Meeting Date: | 5/28/2014 |
| Sponsor(s): | Burnett (27) |
| Type: | Ordinance |
| Title: | Grant(s) of privilege in public way for Empire Cooler Service, Inc. |
| Committee(s) Assignment: | Committee on Transportation and Public Way |

ORDINANCE
EMPIRE COOLER SERVICE INC
Acct. No. 2849 - 1
Permit No. 1112935

Be It Ordained by the City Council of the City of Chicago:

SECTION 1. Permission and authority are hereby given and granted to EMPIRE COOLER SERVICE INC, upon the terms and subject to the conditions of this ordinance to maintain and use one (1) sign(s) projecting over the public right-of-way attached to its premises known as 940 W. Chicago Ave..

Said sign structure(s) measures as follows; along W CHICAGO AVE:
One (1) at eight (8) feet in length, three (3) feet in height and fourteen (14) feet above grade level.

The location of said privilege shall be as shown on prints kept on file with the Department of Business Affairs and Consumer Protection and the Office of the City Clerk.

Said privilege shall be constructed in accordance with plans and specifications approved by the Department of Transportation (Division of Project Development) and Zoning Department - Signs.

This grant of privilege in the public way shall be subject to the provisions of Section 10-28-015 and all other required provisions of the Municipal Code of Chicago.

The grantee shall pay to the City of Chicago as compensation for the privilege #1112935 herein granted the sum of one hundred (\$100.00) per annum in advance.

A 25% penalty will be added for payments received after due date.

The permit holder agrees to hold the City of Chicago harmless for any damage, relocation or replacement costs associated with damage, relocation or removal of private property caused by the City performing work in the public way.

Authority herein given and granted for a period of five (5) years from and after 05/13/2014.

Alderman 
Walter Burnett Jr. 27th Ward

940 W. CHICAGO AVENUE

**EMPIRE
COOLER SERVICE
INC.**

HEIGHT OF
STRUCTURE
3'

LENGTH OF
STRUCTURE 8'

DEPTH OF
STRUCTURE 1'

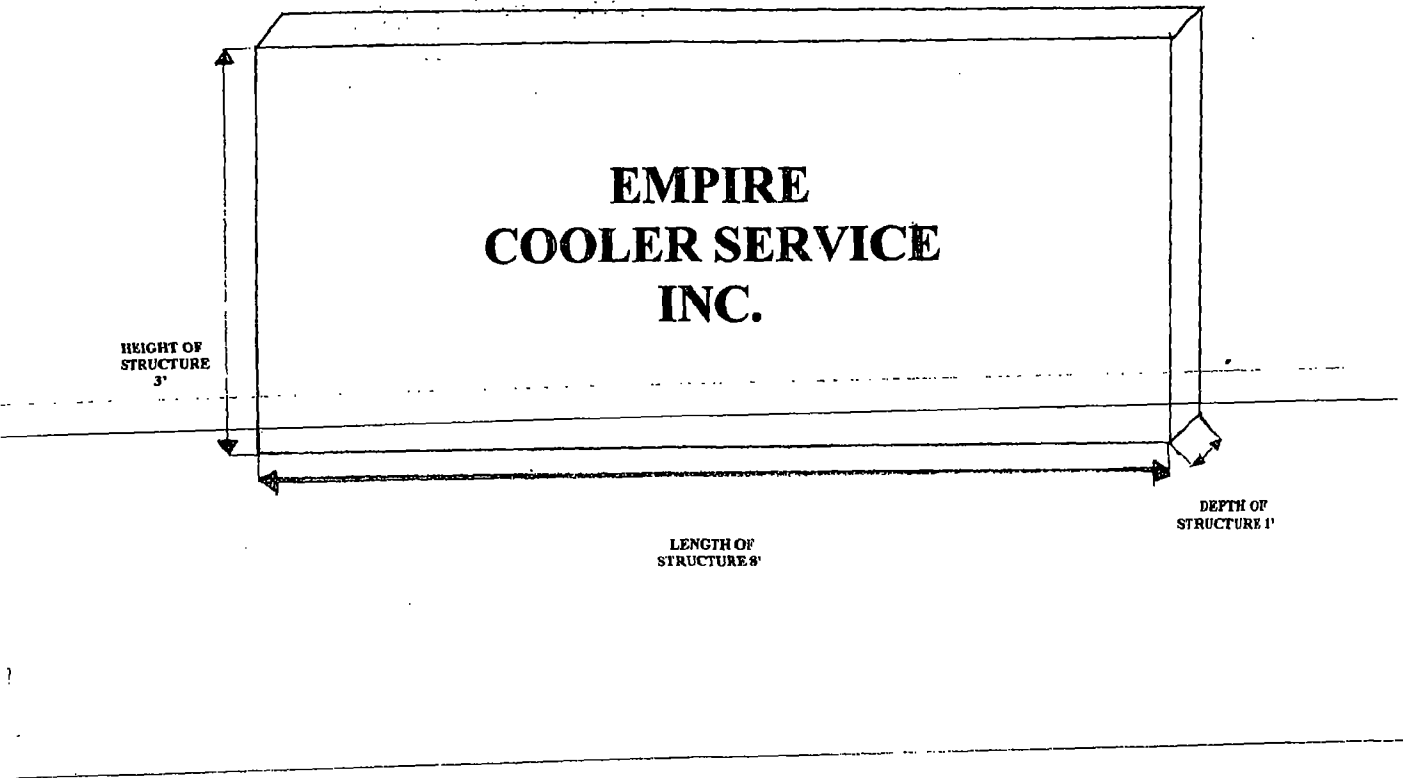



City of Chicago



O2014-4317

Office of the City Clerk

Document Tracking Sheet

| | |
|---------------------------------|--|
| Meeting Date: | 5/28/2014 |
| Sponsor(s): | Burnett (27) |
| Type: | Ordinance |
| Title: | Grant(s) of privilege in public way for Kaiser Tiger |
| Committee(s) Assignment: | Committee on Transportation and Public Way |

ORDINANCE
KAISER TIGER
Acct. No. 22928 - 1
Permit No. 1112842

Be It Ordained by the City Council of the City of Chicago:

SECTION 1. Permission and authority are hereby given and granted to KAISER TIGER, upon the terms and subject to the conditions of this ordinance to maintain and use, as now constructed, eleven (11) Light Fixture(s) projecting over the public right-of-way adjacent to its premises known as 1415 W. Randolph St..

Said Light Fixture(s) at W Randolph St measure(s):

Eleven (11) at one (1) foot in length, two point three three (2.33) feet in width and sixteen (16) feet above grade level.

The location of said privilege shall be as shown on prints kept on file with the Department of Business Affairs and Consumer Protection and the Office of the City Clerk.

Said privilege shall be constructed in accordance with plans and specifications approved by the Department of Transportation (Division of Project Development).

This grant of privilege in the public way shall be subject to the provisions of Section 10-28-015 and all other required provisions of the Municipal Code of Chicago.

The grantee shall pay to the City of Chicago as compensation for the privilege #1112842 herein granted the sum of one hundred twenty-five (\$125.00) per annum in advance.

A 25% penalty will be added for payments received after due date.

The permit holder agrees to hold the City of Chicago harmless for any damage, relocation or replacement costs associated with damage, relocation or removal of private property caused by the City performing work in the public way.

Authority herein given and granted for a period of five (5) years from and after Date of Passage.

Alderman

Walter Burnett Jr. 27th Ward

NAME: ANGEL'S SHARE DBA KAISER TIGER

ADDRESS: 1415 W. RANDOLPH ST. CHICAGO IL 60607

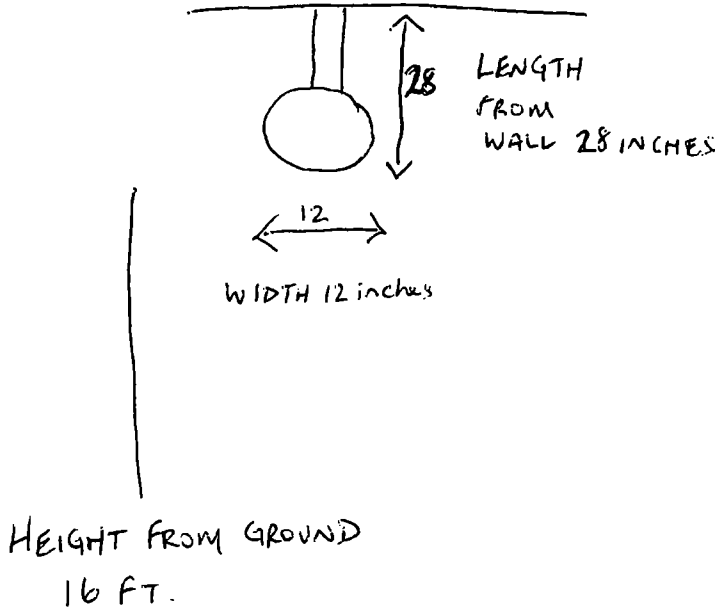



City of Chicago



O2014-4320

Office of the City Clerk

Document Tracking Sheet

| | |
|---------------------------------|--|
| Meeting Date: | 5/28/2014 |
| Sponsor(s): | Burnett (27) |
| Type: | Ordinance |
| Title: | Grant(s) of privilege in public way for Lou Malnati's Pizzeria |
| Committee(s) Assignment: | Committee on Transportation and Public Way |

ORDINANCE
LOU MALNATI'S PIZZERIA
Acct. No. 50161 - 18
Permit No. 1112535

Be It Ordained by the City Council of the City of Chicago:

SECTION 1. Permission and authority are hereby given and granted to LOU MALNATI'S PIZZERIA, upon the terms and subject to the conditions of this ordinance to maintain and use, as now constructed, six (6) Door Swing(s) on the public right-of-way adjacent to its premises known as 1235 W. Randolph St..

Said Door Swing(s) at W. Randolph Street measure(s):

Six (6) at one (1) foot in length, and two point zero eight (2.08) feet in width for a total of twelve point four eight (12.48) square feet.

The location of said privilege shall be as shown on prints kept on file with the Department of Business Affairs and Consumer Protection and the Office of the City Clerk.

Said privilege shall be constructed in accordance with plans and specifications approved by the Department of Transportation (Division of Project Development).

This grant of privilege in the public way shall be subject to the provisions of Section 10-28-015 and all other required provisions of the Municipal Code of Chicago.

The grantee shall pay to the City of Chicago as compensation for the privilege #1112535 herein granted the sum of four hundred fifty (\$450.00) per annum in advance.

A 25% penalty will be added for payments received after due date.

The permit holder agrees to hold the City of Chicago harmless for any damage, relocation or replacement costs associated with damage, relocation or removal of private property caused by the City performing work in the public way.

Authority herein given and granted for a period of five (5) years from and after Date of Passage.

Alderman 

Walter Burnett Jr. 27th Ward

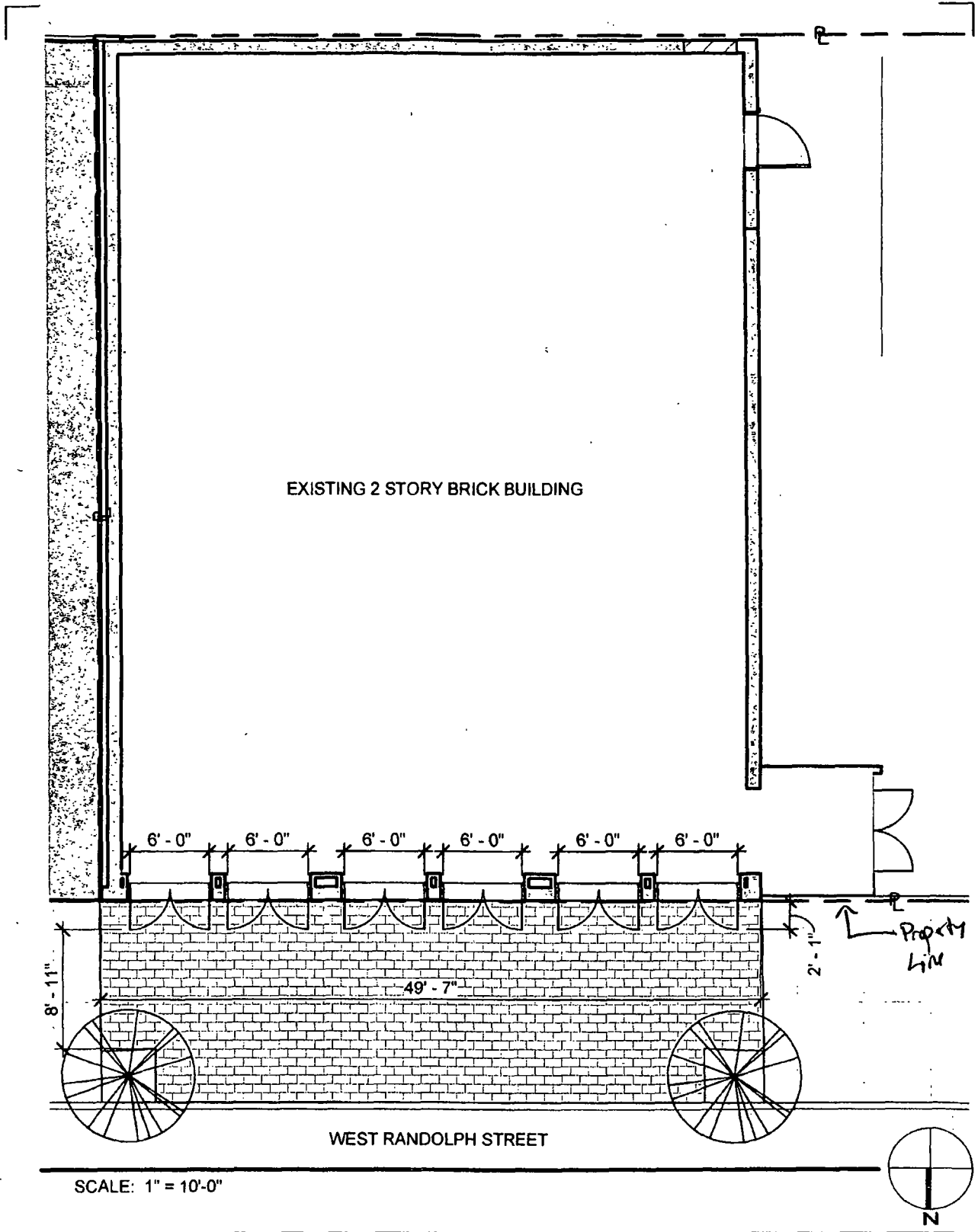

S:\3197 - Lou Malnati - West Chicago\CAD\Malnati's West Loop.rvt
4/16/2014 4:59:44 PM

| | | | | | |
|--|--|---|------------------|--|-----------------------------|
| KNAUER <small>Knauer Incorporated 720 Waukegan Road, Suite 200 Deerfield, IL 60015</small> | <small>(847) 948 9500 (847) 948 9599 fax www.knauerinc.com</small> | PUBLIC WAY APPLICATION LOU MALNATI'S - WEST LOOP 1235 W RANDOLPH STREET CHICAGO, ILLINOIS 60607 | | PROJECT NO: 3197 DRAWN BY: JK CHECKED BY: MM | PUBLIC WAY APPLICATION PLAN |
| | | <small>© 2014 KNAUER INCORPORATED</small> | DATE: 04/16/2014 | A-101-PWA | |



City of Chicago



O2014-4332

Office of the City Clerk

Document Tracking Sheet

| | |
|---------------------------------|---|
| Meeting Date: | 5/28/2014 |
| Sponsor(s): | Burnett (27) |
| Type: | Ordinance |
| Title: | Grant(s) of privilege in public way for Michalik Funeral Home |
| Committee(s) Assignment: | Committee on Transportation and Public Way |

ORDINANCE
MICHALIK FUNERAL HOME
Acct. No. 25396 - 1
Permit No. 1113016

Be It Ordained by the City Council of the City of Chicago:

SECTION 1. Permission and authority are hereby given and granted to MICHALIK FUNERAL HOME, upon the terms and subject to the conditions of this ordinance to maintain and use one (1) sign(s) projecting over the public right-of-way attached to its premises known as 1056 W. Chicago Ave..

Said sign structure(s) measures as follows; along W CHICAGO AVE:
One (1) at six (6) feet in length, four point three three (4.33) feet in height and nine (9) feet above grade level.

The location of said privilege shall be as shown on prints kept on file with the Department of Business Affairs and Consumer Protection and the Office of the City Clerk.

Said privilege shall be constructed in accordance with plans and specifications approved by the Department of Transportation (Division of Project Development) and Zoning Department - Signs.

This grant of privilege in the public way shall be subject to the provisions of Section 10-28-015 and all other required provisions of the Municipal Code of Chicago.

The grantee shall pay to the City of Chicago as compensation for the privilege #1113016 herein granted the sum of three hundred (\$300.00) per annum in advance.

A 25% penalty will be added for payments received after due date.

The permit holder agrees to hold the City of Chicago harmless for any damage, relocation or replacement costs associated with damage, relocation or removal of private property caused by the City performing work in the public way.

Authority herein given and granted for a period of five (5) years from and after 05/13/2014.

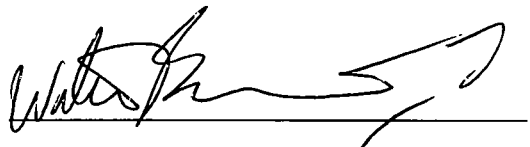
Alderman 
Walter Burnett Jr. 27th Ward





City of Chicago



O2014-4335

Office of the City Clerk

Document Tracking Sheet

| | |
|---------------------------------|---|
| Meeting Date: | 5/28/2014 |
| Sponsor(s): | Burnett (27) |
| Type: | Ordinance |
| Title: | Grant(s) of privilege in public way for Mr. Clarence L. Burch |
| Committee(s) Assignment: | Committee on Transportation and Public Way |

ORDINANCE
MR. CLARENCE L. BURCH
Acct. No. 68615 - 1
Permit No. 1113006

Be It Ordained by the City Council of the City of Chicago:

SECTION 1. Permission and authority are hereby given and granted to MR. CLARENCE L. BURCH, upon the terms and subject to the conditions of this ordinance to maintain and use, as now constructed, one (1) Fire Escape(s) projecting over the public right-of-way adjacent to its premises known as 1251 N. Clybourn Ave..

Said Fire Escape(s) at N Clybourn measure(s):

One (1) at thirty-four (34) feet in length, and two (2) feet in width for a total of sixty-eight (68) square feet.

The location of said privilege shall be as shown on prints kept on file with the Department of Business Affairs and Consumer Protection and the Office of the City Clerk.

Said privilege shall be constructed in accordance with plans and specifications approved by the Department of Transportation (Division of Project Development).

This grant of privilege in the public way shall be subject to the provisions of Section 10-28-015 and all other required provisions of the Municipal Code of Chicago.

The grantee shall pay to the City of Chicago as compensation for the privilege #1113006 herein granted the sum of four hundred (\$400.00) per annum in advance.

A 25% penalty will be added for payments received after due date.

The permit holder agrees to hold the City of Chicago harmless for any damage, relocation or replacement costs associated with damage, relocation or removal of private property caused by the City performing work in the public way.

Authority herein given and granted for a period of five (5) years from and after 05/24/2014.

Alderman



Walter Burnett Jr. 27th Ward

CLEVELAND

N. CLEVELAND AVE.

76.00'

34.00'

5.00'

26.00

125' N.

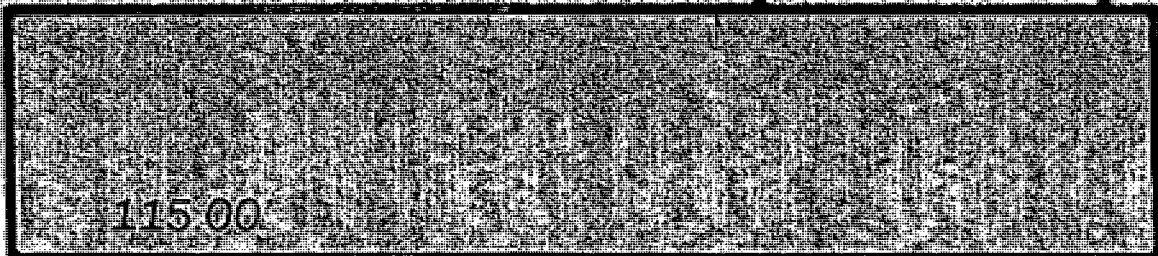

LAND AREA



City of Chicago



O2014-4383

Office of the City Clerk

Document Tracking Sheet

| | |
|---------------------------------|--|
| Meeting Date: | 5/28/2014 |
| Sponsor(s): | Burnett (27) |
| Type: | Ordinance |
| Title: | Grant(s) of privilege in public way for Prairie Material |
| Committee(s) Assignment: | Committee on Transportation and Public Way |

ORDINANCE
PRAIRIE MATERIAL
Acct. No. 333231 - 7
Permit No. 1112504

Be It Ordained by the City Council of the City of Chicago:

SECTION 1. Permission and authority are hereby given and granted to PRAIRIE MATERIAL, upon the terms and subject to the conditions of this ordinance to maintain and use, as now constructed, Occupation of Space under the public right-of-way adjacent to its premises known as 835 N. Peoria St.. Existing occupation of space is used for storage of vehicles and other personal property underneath the roadway overpass for the bridge over the Chicago River at West Chicago Avenue and North Halsted Street.

Said Occupation of Space(s) at N. Halsted Street measure(s):

One (1) at three hundred seventy-two (372) feet in length, and forty-seven (47) feet in width for a total of seventeen thousand four hundred eighty-four (17484) square feet.

The location of said privilege shall be as shown on prints kept on file with the Department of Business Affairs and Consumer Protection and the Office of the City Clerk.

Said privilege shall be constructed in accordance with plans and specifications approved by the Department of Planning and Development, Department of Transportation (Division of Project Development), and Department of Transportation (Office of Underground Coordination).

This grant of privilege in the public way shall be subject to the provisions of Section 10-28-015 and all other required provisions of the Municipal Code of Chicago.

The grantee shall pay to the City of Chicago as compensation for the privilege #1112504 herein granted the sum of three thousand eight hundred five (\$3,805.00) per annum in advance.

A 25% penalty will be added for payments received after due date.

The permit holder agrees to hold the City of Chicago harmless for any damage, relocation or replacement costs associated with damage, relocation or removal of private property caused by the City performing work in the public way.

Authority herein given and granted for a period of five (5) years from and after 02/06/2014.

Alderman 

Walter Burnett Jr. 27th Ward

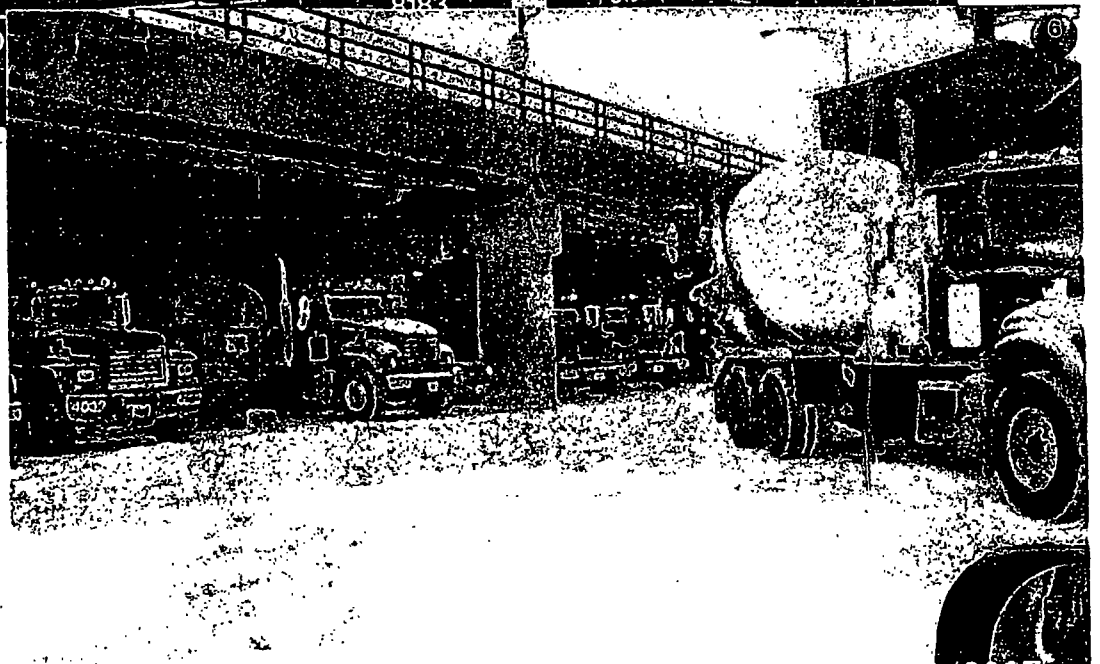
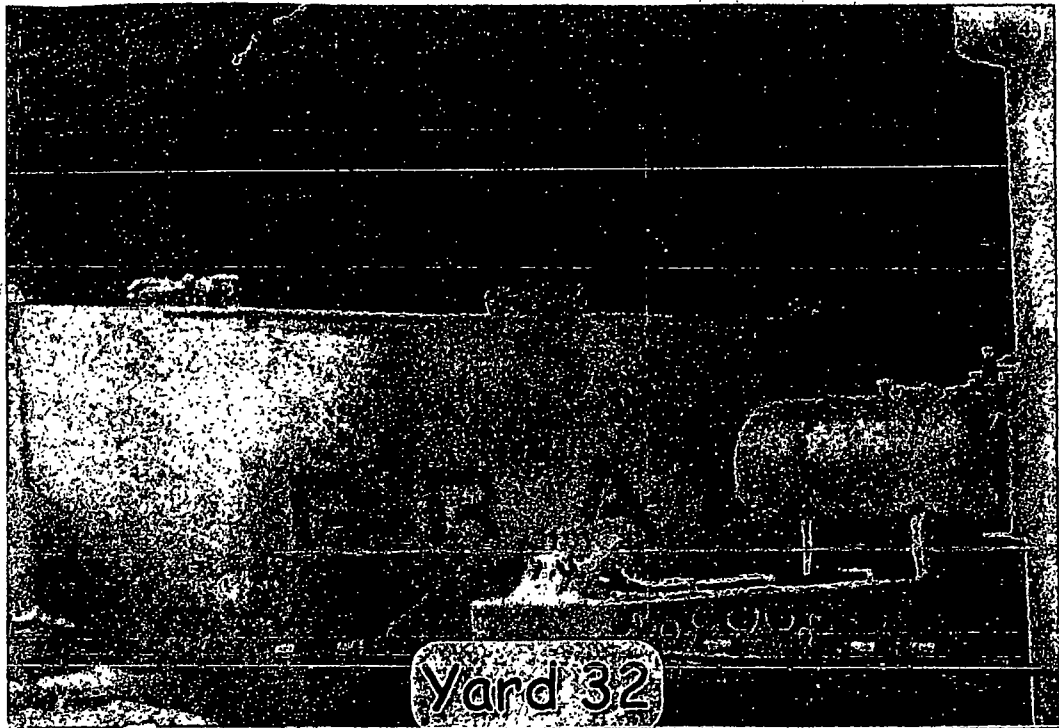



City of Chicago



O2014-4389

Office of the City Clerk

Document Tracking Sheet

| | |
|---------------------------------|--|
| Meeting Date: | 5/28/2014 |
| Sponsor(s): | Burnett (27) |
| Type: | Ordinance |
| Title: | Grant(s) of privilege in public way for Roosevelt Square II Limited Partnership - 1302 W Roosevelt Rd |
| Committee(s) Assignment: | Committee on Transportation and Public Way |

ORDINANCE
ROOSEVELT SQUARE II LIMITED PARTNERSHIP
Acct. No. 320780 - 7
Permit No. 1109902

Be It Ordained by the City Council of the City of Chicago:

SECTION 1. Permission and authority are hereby given and granted to ROOSEVELT SQUARE II LIMITED PARTNERSHIP, upon the terms and subject to the conditions of this ordinance to maintain and use, as now constructed, two (2) Planter(s) on the public right-of-way for beautification purposes adjacent to its premises known as 1302 W. Roosevelt Rd..

Said Planter(s) at W. Roosevelt Road measure(s):

One (1) at thirty-five (35) feet in length, and six point one seven (6.17) feet in width for a total of two hundred fifteen point nine five (215.95) square feet.

One (1) at thirty-five (35) feet in length, and six point zero eight (6.08) feet in width for a total of two hundred twelve point eight (212.8) square feet.

Grantee must allow the required clear and unobstructed space for pedestrian passage at all times per rules and regulations approved by the Department of Transportation.

The location of said privilege shall be as shown on prints kept on file with the Department of Business Affairs and Consumer Protection and the Office of the City Clerk.

Said privilege shall be constructed in accordance with plans and specifications approved by the Department of Planning and Development and Department of Transportation (Division of Project Development).

This grant of privilege in the public way shall be subject to the provisions of Section 10-28-015 and all other required provisions of the Municipal Code of Chicago.

The grantee shall pay to the City of Chicago as compensation for the privilege #1109902 herein granted the sum of zero (\$.00) per annum in advance.

A 25% penalty will be added for payments received after due date.

The permit holder agrees to hold the City of Chicago harmless for any damage, relocation or replacement costs associated with damage, relocation or removal of private property caused by the City performing work in the public way.

Authority herein given and granted for a period of five (5) years from and after 06/11/2013.

Alderman



Jason Ervin 28th Ward

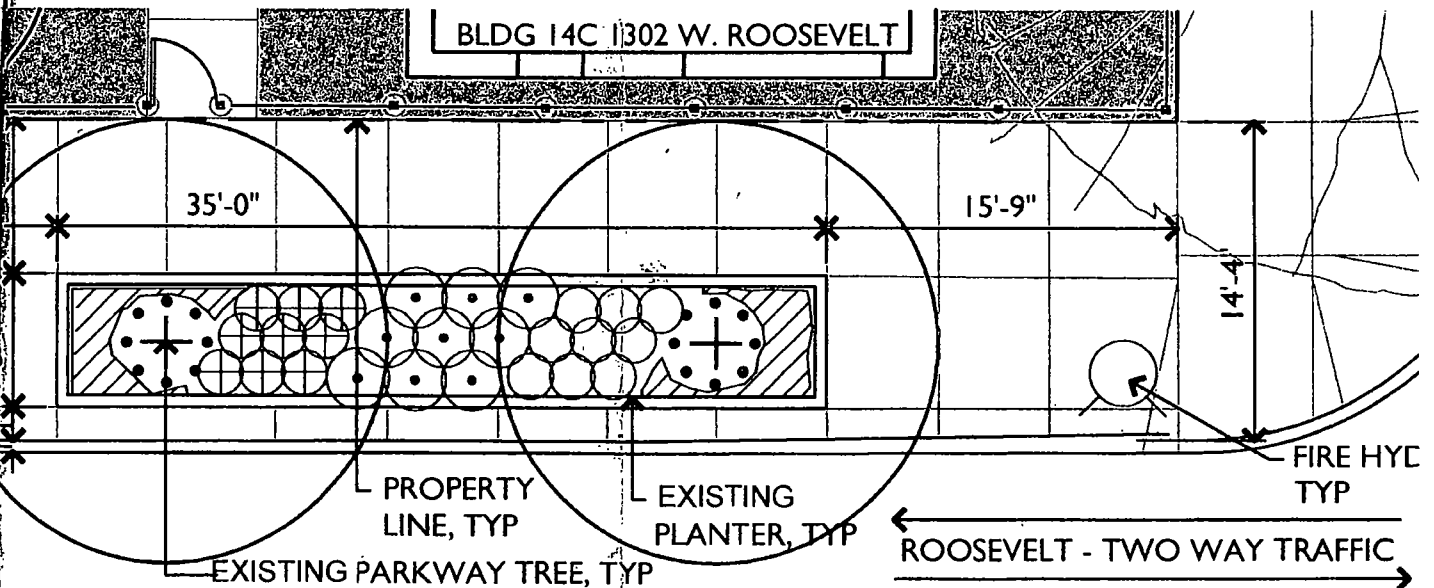
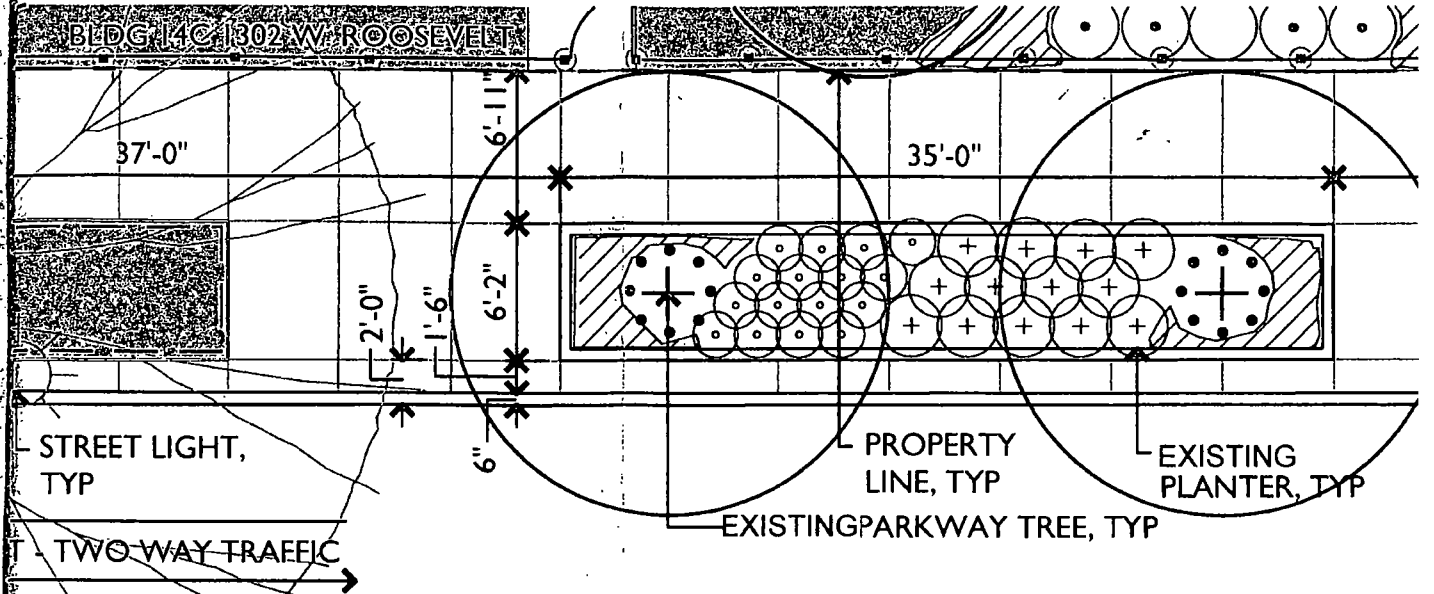

ROOSEVELT SQUARE PHASE 2
BUILDING 14 C 1302 WEST ROOSEVELT
WOLFF LANDSCAPE ARCHITECTURE

SCALE: 1.



City of Chicago



O2014-4403

Office of the City Clerk

Document Tracking Sheet

Meeting Date: 5/28/2014

Sponsor(s): Burnett (27)

Type: Ordinance

Title: Grant(s) of privilege in public way for Roosevelt Square II
Limited Partnership - 1328-1352 W Roosevelt Rd

Committee(s) Assignment: Committee on Transportation and Public Way

ORDINANCE
ROOSEVELT SQUARE II LIMITED PARTNERSHIP
Acct. No. 320780 - 9
Permit No. 1109901

Be It Ordained by the City Council of the City of Chicago:

SECTION 1. Permission and authority are hereby given and granted to ROOSEVELT SQUARE II LIMITED PARTNERSHIP, upon the terms and subject to the conditions of this ordinance to maintain and use, as now constructed, four (4) Planter(s) on the public right-of-way for beautification purposes adjacent to its premises known as 1328-52 W. Roosevelt Rd..

Said Planter(s) at W. Roosevelt Road measure(s):

One (1) at thirty-five (35) feet in length, and seven point zero eight (7.08) feet in width for a total of two hundred forty-seven point eight (247.8) square feet.

One (1) at thirty-five (35) feet in length, and six point nine three (6.93) feet in width for a total of two hundred forty-two point five five (242.55) square feet.

One (1) at thirty-five (35) feet in length, and six point seven five (6.75) feet in width for a total of two hundred thirty-six point two five (236.25) square feet.

One (1) at twenty (20) feet in length, and six point eight three (6.83) feet in width for a total of one hundred thirty-six point six (136.6) square feet.

Grantee must allow the required clear and unobstructed space for pedestrian passage at all times per rules and regulations approved by the Department of Transportation.

The location of said privilege shall be as shown on prints kept on file with the Department of Business Affairs and Consumer Protection and the Office of the City Clerk.

Said privilege shall be constructed in accordance with plans and specifications approved by the Department of Planning and Development and Department of Transportation (Division of Project Development).

This grant of privilege in the public way shall be subject to the provisions of Section 10-28-015 and all other required provisions of the Municipal Code of Chicago.

The grantee shall pay to the City of Chicago as compensation for the privilege #1109901 herein granted the sum of zero (\$.00) per annum in advance.

A 25% penalty will be added for payments received after due date.

The permit holder agrees to hold the City of Chicago harmless for any damage, relocation or replacement costs associated with damage, relocation or removal of private property caused by the City performing work in the public way.

Authority herein given and granted for a period of five (5) years from and after 06/11/2013.

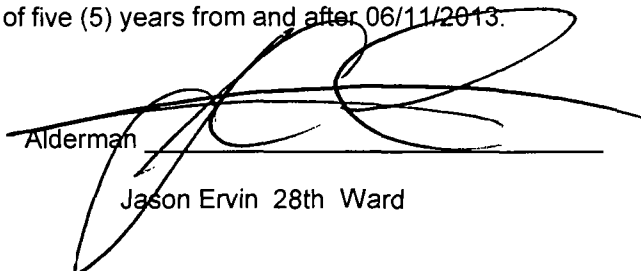
Alderman
Jason Ervin 28th Ward

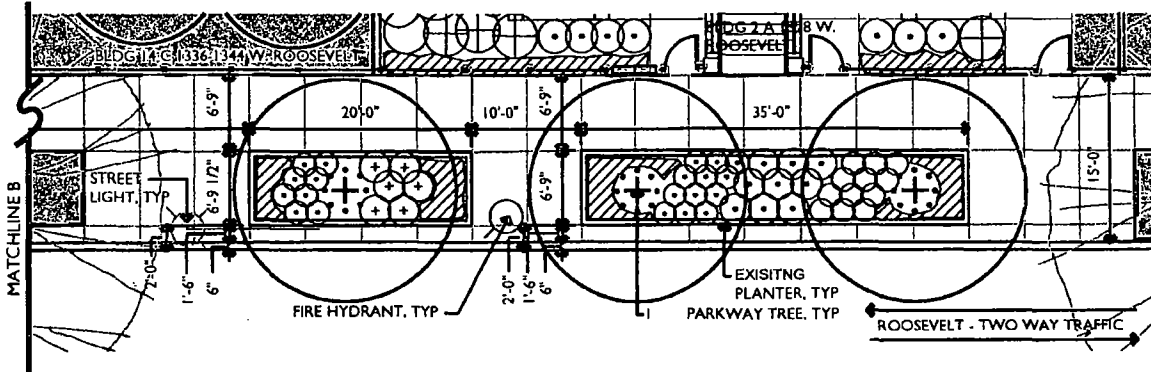
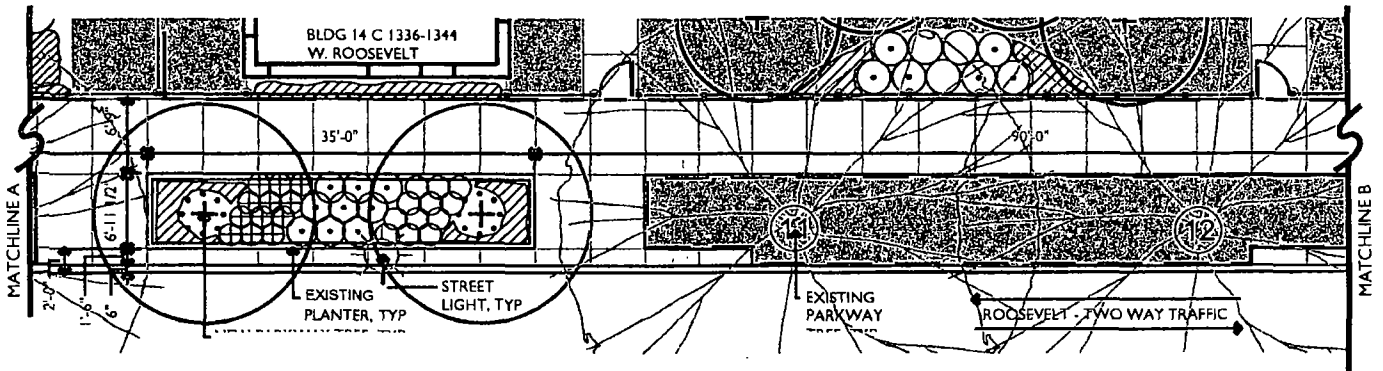
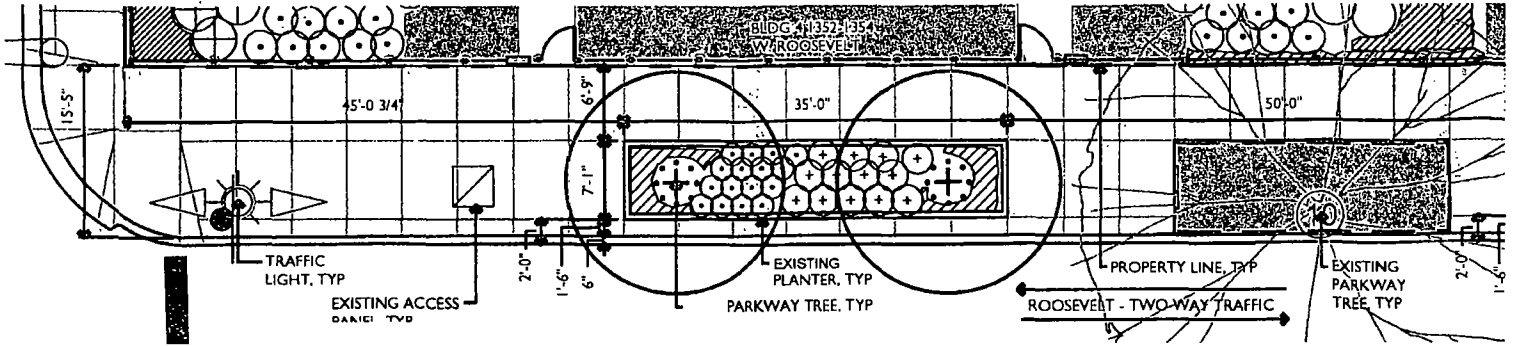

ROOSEVELT SQUARE PHASE 2
1328 - 1352 WEST ROOSEVELT
BUILDING 2A 1328 WEST ROOSEVELT
BUILDING 14C 1336 - 1344 WEST ROOSEVELT
BUILDING 4 1352 - 1354 WEST ROOSEVELT

WOLFF LANDSCAPE ARCHITECTURE
1-24-08

SCALE



City of Chicago



O2014-4412

Office of the City Clerk

Document Tracking Sheet

| | |
|---------------------------------|---|
| Meeting Date: | 5/28/2014 |
| Sponsor(s): | Burnett (27) |
| Type: | Ordinance |
| Title: | Grant(s) of privilege in public way for Thalia Spice Asian Fusion Bistro - light fixtures |
| Committee(s) Assignment: | Committee on Transportation and Public Way |

ORDINANCE
THALIA SPICE ASIAN FUSION BISTRO
Acct. No. 320872 - 1
Permit No. 1113043

Be It Ordained by the City Council of the City of Chicago:

SECTION 1. Permission and authority are hereby given and granted to THALIA SPICE ASIAN FUSION BISTRO, upon the terms and subject to the conditions of this ordinance to maintain and use, as now constructed, three (3) Light Fixture(s) projecting over the public right-of-way adjacent to its premises known as 833 W. Chicago Ave..

Said Light Fixture(s) at W. Chicago Avenue measure(s):

Three (3) at point six seven (.67) feet in length, point five eight (.58) feet in width and fourteen (14) feet above grade level.

The location of said privilege shall be as shown on prints kept on file with the Department of Business Affairs and Consumer Protection and the Office of the City Clerk.

Said privilege shall be constructed in accordance with plans and specifications approved by the Department of Transportation (Division of Project Development).

This grant of privilege in the public way shall be subject to the provisions of Section 10-28-015 and all other required provisions of the Municipal Code of Chicago.

The grantee shall pay to the City of Chicago as compensation for the privilege #1113043 herein granted the sum of eighty-five (\$85.00) per annum in advance.

A 25% penalty will be added for payments received after due date.

The permit holder agrees to hold the City of Chicago harmless for any damage, relocation or replacement costs associated with damage, relocation or removal of private property caused by the City performing work in the public way.

Authority herein given and granted for a period of five (5) years from and after 01/13/2014.

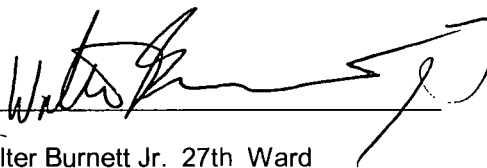
Alderman 
Walter Burnett Jr. 27th Ward

Application for Public Way Use

Thalia Spice Asian Fusion Bistro & Bar
Thalia Fusion, Inc.
833 W Chicago Ave (Light fixtures location at 730 N. Green)
Chicago, IL 60622
312.226.6020 tel
312.226.6102 FAX

RENEWAL
PERMIT # 1082976

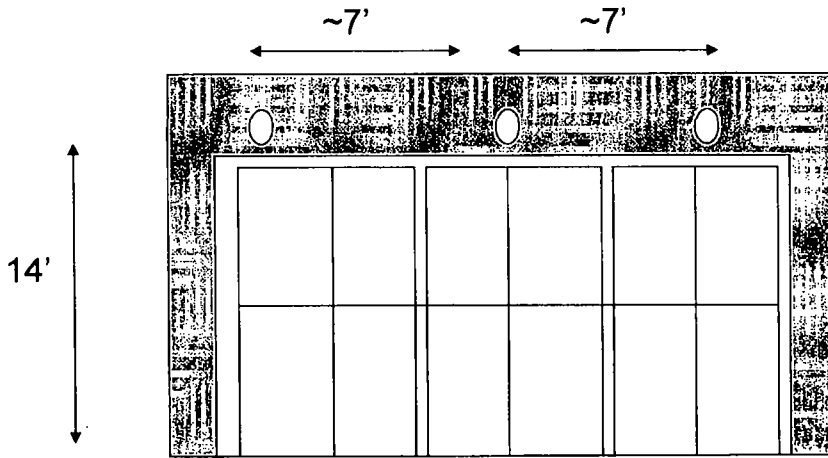

3 x Light Fixtures each:

- 7" Width
- 8" Height
- 8" Depth over building property line.

NO CHANGES FROM ORIGINAL 2008 APPLICATION/PERMIT



City of Chicago



O2014-4414

Office of the City Clerk

Document Tracking Sheet

| | |
|---------------------------------|--|
| Meeting Date: | 5/28/2014 |
| Sponsor(s): | Burnett (27) |
| Type: | Ordinance |
| Title: | Grant(s) of privilege in public way for Thalia Spice Asian Fusion Bistro - signs |
| Committee(s) Assignment: | Committee on Transportation and Public Way |

ORDINANCE
THALIA SPICE ASIAN FUSION BISTRO
Acct. No. 320872 - 1
Permit No. 1113042

Be It Ordained by the City Council of the City of Chicago:

SECTION 1. Permission and authority are hereby given and granted to THALIA SPICE ASIAN FUSION BISTRO, upon the terms and subject to the conditions of this ordinance to maintain and use two (2) sign(s) projecting over the public right-of-way attached to its premises known as 833 W. Chicago Ave..

Said sign structure(s) measures as follows; along W. Chicago Ave:
One (1) at five (5) feet in length, five (5) feet in height and ten (10) feet above grade level.

Said sign structure(s) measures as follows; along W. Chicago:
One (1) at six (6) feet in length, four (4) feet in height and twelve (12) feet above grade level.

The location of said privilege shall be as shown on prints kept on file with the Department of Business Affairs and Consumer Protection and the Office of the City Clerk.

Said privilege shall be constructed in accordance with plans and specifications approved by the Department of Transportation (Division of Project Development) and Zoning Department - Signs.

This grant of privilege in the public way shall be subject to the provisions of Section 10-28-015 and all other required provisions of the Municipal Code of Chicago.

The grantee shall pay to the City of Chicago as compensation for the privilege #1113042 herein granted the sum of four hundred (\$400.00) per annum in advance.

A 25% penalty will be added for payments received after due date.

The permit holder agrees to hold the City of Chicago harmless for any damage, relocation or replacement costs associated with damage, relocation or removal of private property caused by the City performing work in the public way.

Authority herein given and granted for a period of five (5) years from and after 11/19/2013.

Alderman



Walter Burnett Jr. 27th Ward

Application for Public Way Use
Sign # [REDACTED]

Thalia Fusion, Inc
Thalia Spice Asian Fusion Bistro & Bar
833 W Chicago Ave (sign location)
Chicago, IL 60622

RENEWAL
(NO CHANGES)

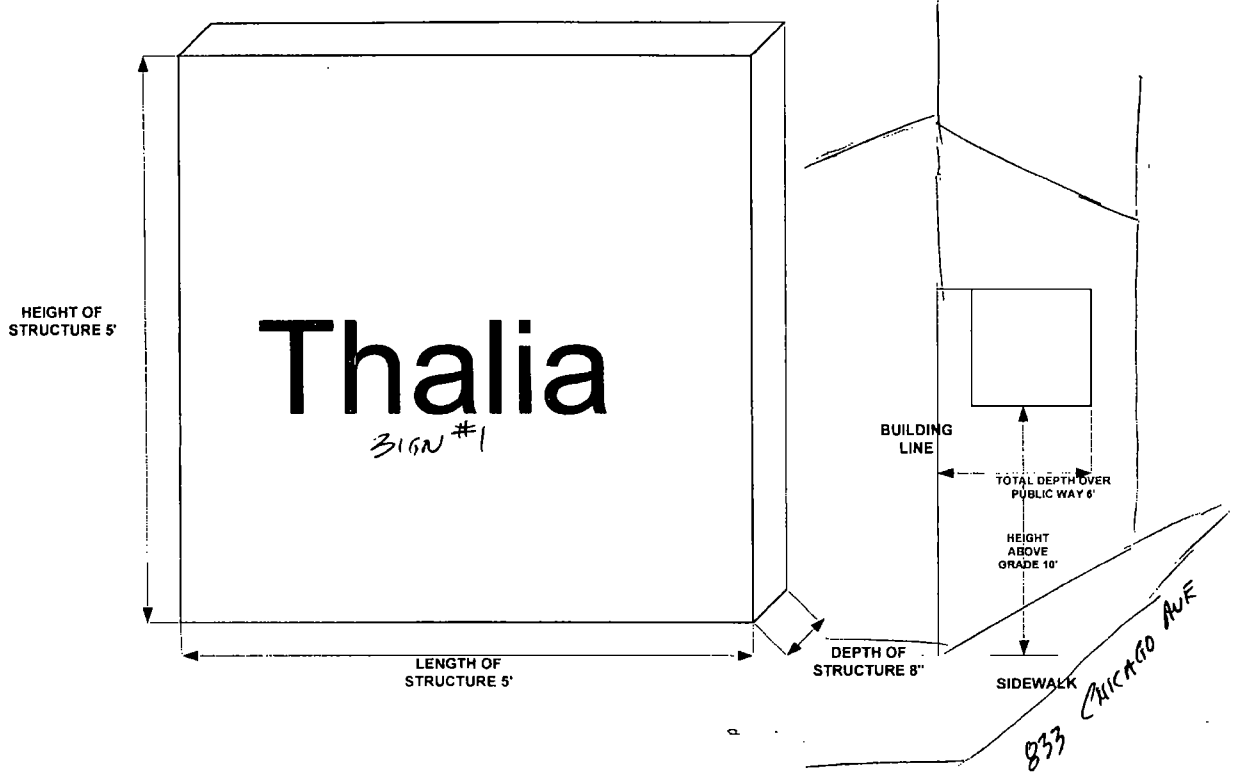



City of Chicago



O2014-4417

Office of the City Clerk

Document Tracking Sheet

| | |
|---------------------------------|---|
| Meeting Date: | 5/28/2014 |
| Sponsor(s): | Burnett (27) |
| Type: | Ordinance |
| Title: | Grant(s) of privilege in public way for Transit |
| Committee(s) Assignment: | Committee on Transportation and Public Way |

ORDINANCE
TRANSIT
Acct. No. 82054 - 1
Permit No. 1112971

Be It Ordained by the City Council of the City of Chicago:

SECTION 1. Permission and authority are hereby given and granted to TRANSIT, upon the terms and subject to the conditions of this ordinance to maintain and use, as now constructed, eight (8) Light Fixture(s) projecting over the public right-of-way adjacent to its premises known as 1431 W. Lake St..

Said Light Fixture(s) at W. LAKE STREET measure(s):

- One (1) at one point four two (1.42) foot in length, point five (.5) feet in width and seven (7) feet above grade level.
- One (1) at one point four two (1.42) foot in length, point five (.5) feet in width and seven (7) feet above grade level.
- One (1) at one point four two (1.42) foot in length, point five (.5) feet in width and twelve (12) feet above grade level.
- One (1) at one point four two (1.42) foot in length, point five (.5) feet in width and twelve (12) feet above grade level.
- One (1) at one point four two (1.42) foot in length, point five (.5) feet in width and twelve (12) feet above grade level.
- One (1) at one point four two (1.42) foot in length, point five (.5) feet in width and twelve (12) feet above grade level.
- One (1) at one point four two (1.42) foot in length, point five (.5) feet in width and twelve (12) feet above grade level.
- One (1) at one point four two (1.42) foot in length, point five (.5) feet in width and twelve (12) feet above grade level.

The location of said privilege shall be as shown on prints kept on file with the Department of Business Affairs and Consumer Protection and the Office of the City Clerk.

Said privilege shall be constructed in accordance with plans and specifications approved by the Department of Transportation (Division of Project Development).

This grant of privilege in the public way shall be subject to the provisions of Section 10-28-015 and all other required provisions of the Municipal Code of Chicago.

The grantee shall pay to the City of Chicago as compensation for the privilege #1112971 herein granted the sum of one hundred ten (\$110.00) per annum in advance.

A 25% penalty will be added for payments received after due date.

The permit holder agrees to hold the City of Chicago harmless for any damage, relocation or replacement costs associated with damage, relocation or removal of private property caused by the City performing work in the public way.

Authority herein given and granted for a period of five (5) years from and after 07/30/2013.

Alderman 

Walter Burnett Jr. 27th Ward

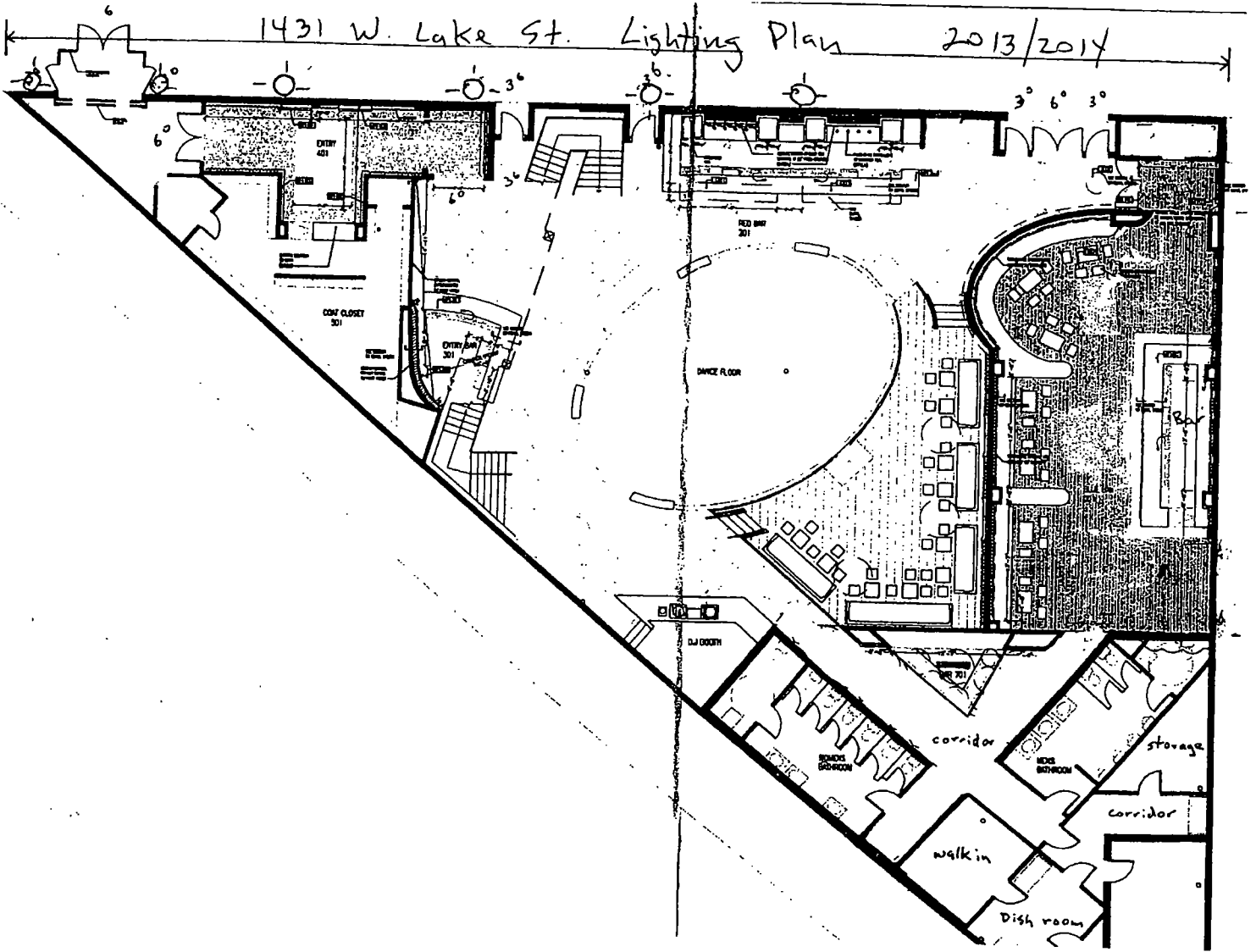



City of Chicago



O2014-4426

Office of the City Clerk

Document Tracking Sheet

| | |
|---------------------------------|---|
| Meeting Date: | 5/28/2014 |
| Sponsor(s): | Burnett (27) |
| Type: | Ordinance |
| Title: | Grant(s) of privilege in public way for VCP Funding 111 LLC, VCP Series 1057 Grand - balconies |
| Committee(s) Assignment: | Committee on Transportation and Public Way |

ORDINANCE
VCP FUNDING 111, LLC, VCP SERIES 1057 GRAND
Acct. No. 389943 - 1
Permit No. 1112725

Be It Ordained by the City Council of the City of Chicago:

SECTION 1. Permission and authority are hereby given and granted to VCP FUNDING 111, LLC, VCP SERIES 1057 GRAND, upon the terms and subject to the conditions of this ordinance to construct, install, maintain and use nine (9) Balcony(s) projecting over the public right-of-way adjacent to its premises known as 1057 W. Grand Ave..

Said Balcony(s) at N. Aberdeen Street measure(s):

Three (3) at eight point five (8.5) feet in length, and four (4) feet in width for a total of one hundred two (102) square feet.

Three (3) at nine point seven five (9.75) feet in length, and four (4) feet in width for a total of one hundred seventeen (117) square feet.

Three (3) at ten point three three (10.33) feet in length, and four (4) feet in width for a total of one hundred twenty-three point nine six (123.96) square feet.

The location of said privilege shall be as shown on prints kept on file with the Department of Business Affairs and Consumer Protection and the Office of the City Clerk.

Said privilege shall be constructed in accordance with plans and specifications approved by the Department of Planning and Development and Department of Transportation (Division of Project Development).

This grant of privilege in the public way shall be subject to the provisions of Section 10-28-015 and all other required provisions of the Municipal Code of Chicago.

The grantee shall pay to the City of Chicago as compensation for the privilege #1112725 herein granted the sum of six hundred seventy-five (\$675.00) per annum in advance.

A 25% penalty will be added for payments received after due date.

The permit holder agrees to hold the City of Chicago harmless for any damage, relocation or replacement costs associated with damage, relocation or removal of private property caused by the City performing work in the public way.

Authority herein given and granted for a period of five (5) years from and after Date of Passage.

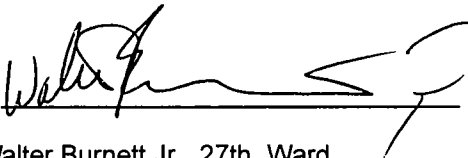
Alderman 
Walter Burnett Jr. 27th Ward

← W GRAND AVE → E

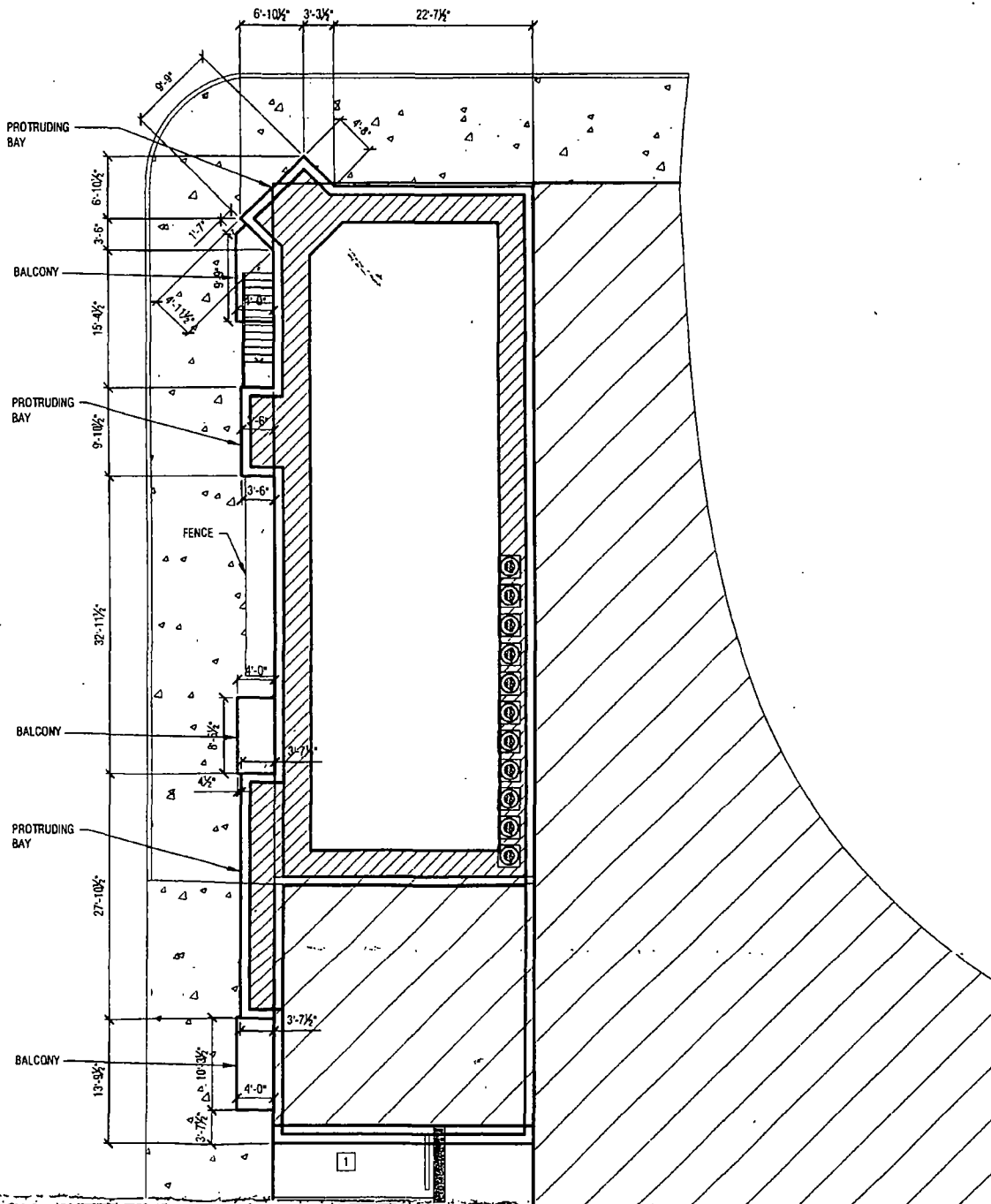



City of Chicago



O2014-4430

Office of the City Clerk

Document Tracking Sheet

| | |
|---------------------------------|---|
| Meeting Date: | 5/28/2014 |
| Sponsor(s): | Burnett (27) |
| Type: | Ordinance |
| Title: | Grant(s) of privilege in public way for VCP Funding 111 LLC, VCP Series 1057 Grand - bay windows |
| Committee(s) Assignment: | Committee on Transportation and Public Way |

ORDINANCE
VCP FUNDING 111, LLC, VCP SERIES 1057 GRAND
Acct. No. 389943 - 1
Permit No. 1112726

Be It Ordained by the City Council of the City of Chicago:

SECTION 1. Permission and authority are hereby given and granted to VCP FUNDING 111, LLC, VCP SERIES 1057 GRAND, upon the terms and subject to the conditions of this ordinance to maintain and use, as now constructed, three (3) Bay Window(s) projecting over the public right-of-way adjacent to its premises known as 1057 W. Grand Ave..

Said Bay Window(s) at N. Aberdeen Street measure(s):

One (1) at nine point nine two (9.92) feet in length, and three point five (3.5) feet in width for a total of thirty-four point seven two (34.72) square feet.

One (1) at nine point seven five (9.75) feet in length, and four point six seven (4.67) feet in width for a total of forty-five point five three (45.53) square feet.

One (1) at twenty-seven point nine two (27.92) feet in length, and two point six seven (2.67) feet in width for a total of seventy-four point five five (74.55) square feet.

The location of said privilege shall be as shown on prints kept on file with the Department of Business Affairs and Consumer Protection and the Office of the City Clerk.

Said privilege shall be constructed in accordance with plans and specifications approved by the Department of Transportation (Division of Project Development).

This grant of privilege in the public way shall be subject to the provisions of Section 10-28-015 and all other required provisions of the Municipal Code of Chicago.

The grantee shall pay to the City of Chicago as compensation for the privilege #1112726 herein granted the sum of two hundred twenty-five (\$225.00) per annum in advance.

A 25% penalty will be added for payments received after due date.

The permit holder agrees to hold the City of Chicago harmless for any damage, relocation or replacement costs associated with damage, relocation or removal of private property caused by the City performing work in the public way.

Authority herein given and granted for a period of five (5) years from and after Date of Passage.

Alderman



Walter Burnett Jr. 27th Ward

BAY WINDOWS
FIRE ESCAPE
COMING OFF

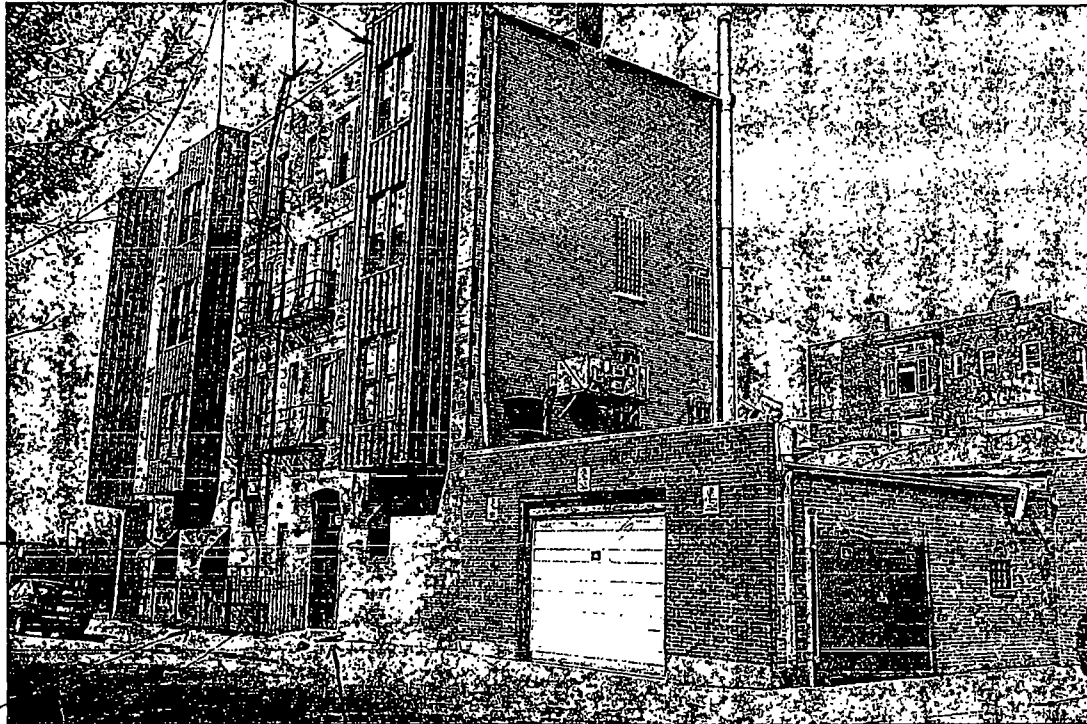

CANOPY
COMING
OFF

STAIRS
TO
BASEMENT

FENCE
FOR
STAIRS

STEP COMING OFF



MARKS
PEST CONTROL
MARTIN WACK
FIRE & SAFETY
EQUIPMENT

LEASE
OR SALE

STAIRS
TO
BASEMENT

FENCE
FOR
STAIRS

STEP COMING OFF



City of Chicago



O2014-4437

Office of the City Clerk

Document Tracking Sheet

| | |
|---------------------------------|---|
| Meeting Date: | 5/28/2014 |
| Sponsor(s): | Burnett (27) |
| Type: | Ordinance |
| Title: | Grant(s) of privilege in public way for VCP Funding 111 LLC, VCP Series 1057 Grand - fence |
| Committee(s) Assignment: | Committee on Transportation and Public Way |

ORDINANCE
VCP FUNDING 111, LLC, VCP SERIES 1057 GRAND
Acct. No. 389943 - 1
Permit No. 1112727

Be It Ordained by the City Council of the City of Chicago:

SECTION 1. Permission and authority are hereby given and granted to VCP FUNDING 111, LLC, VCP SERIES 1057 GRAND, upon the terms and subject to the conditions of this ordinance to maintain and use, as now constructed, Fence on the public right-of-way for security purposes adjacent to its premises known as 1057 W. Grand Ave..

Said Fence at N. Aberdeen Street measure(s):

One (1) at sixteen (16) feet seven (7) inches in length. Existing fence is approximately three (3) feet six (6) inches in height.

The location of said privilege shall be as shown on prints kept on file with the Department of Business Affairs and Consumer Protection and the Office of the City Clerk.

Said privilege shall be constructed in accordance with plans and specifications approved by the Department of Transportation (Division of Project Development).

This grant of privilege in the public way shall be subject to the provisions of Section 10-28-015 and all other required provisions of the Municipal Code of Chicago.

The grantee shall pay to the City of Chicago as compensation for the privilege #1112727 herein granted the sum of zero (\$.00) per annum in advance.

A 25% penalty will be added for payments received after due date.

The permit holder agrees to hold the City of Chicago harmless for any damage, relocation or replacement costs associated with damage, relocation or removal of private property caused by the City performing work in the public way.

Authority herein given and granted for a period of five (5) years from and after Date of Passage.

Alderman

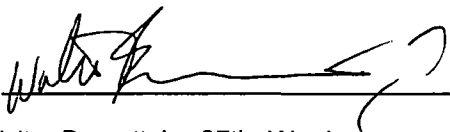

Walter Burnett Jr. 27th Ward

← W GRAND AVE → E

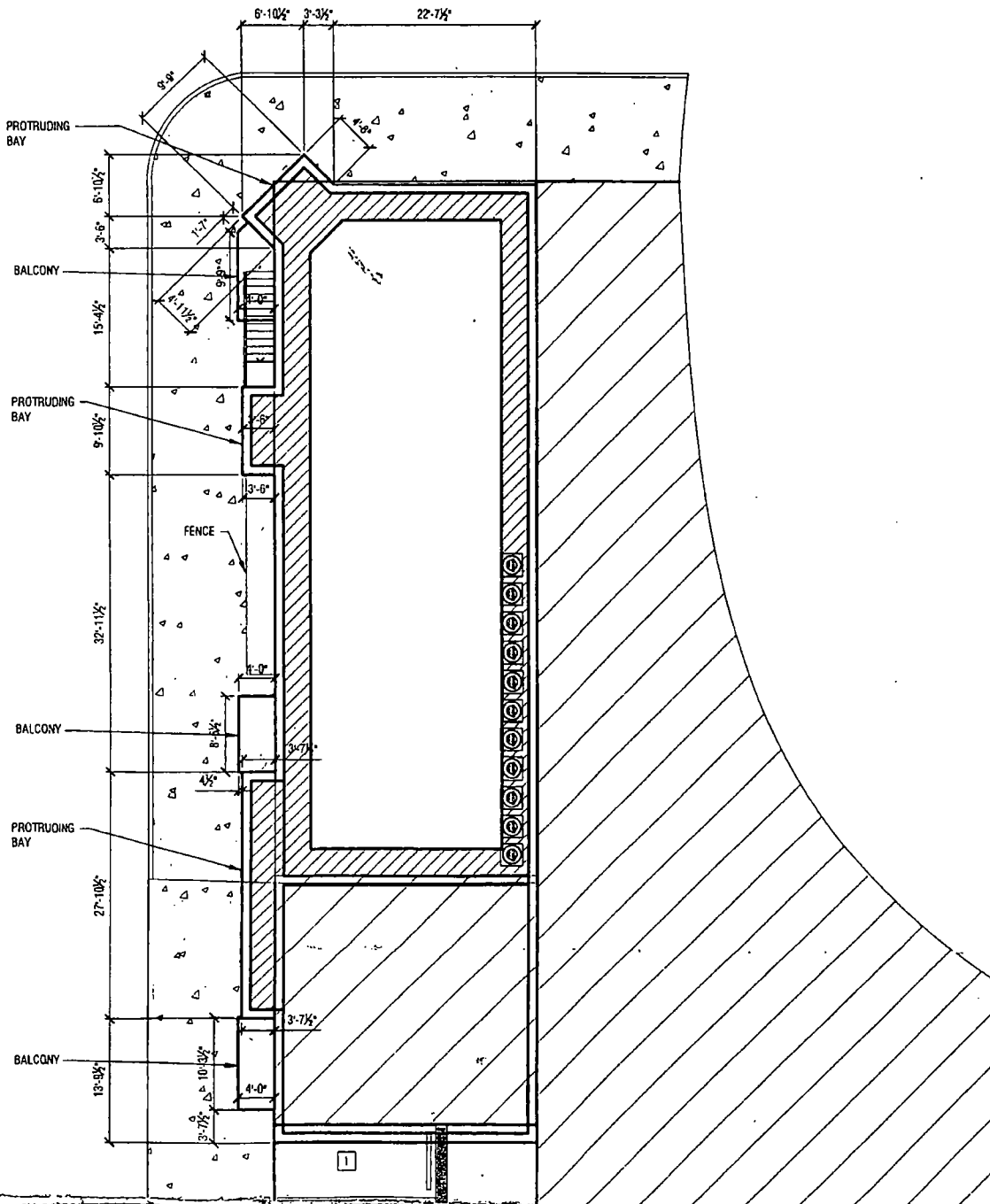



City of Chicago



O2014-4440

Office of the City Clerk

Document Tracking Sheet

| | |
|---------------------------------|---|
| Meeting Date: | 5/28/2014 |
| Sponsor(s): | Burnett (27) |
| Type: | Ordinance |
| Title: | Grant(s) of privilege in public way for VCP Funding 111 LLC, VCP Series 1057 Grand - staircase |
| Committee(s) Assignment: | Committee on Transportation and Public Way |

ORDINANCE
VCP FUNDING 111, LLC, VCP SERIES 1057 GRAND
Acct. No. 389943 - 1
Permit No. 1112728

Be It Ordained by the City Council of the City of Chicago:

SECTION 1. Permission and authority are hereby given and granted to VCP FUNDING 111, LLC, VCP SERIES 1057 GRAND, upon the terms and subject to the conditions of this ordinance to maintain and use, as now constructed, one (1) Stair Case under the public right-of-way adjacent to its premises known as 1057 W. Grand Ave..

Said Stair Case at N. Aberdeen Street measure(s):

One (1) at fifteen point four two (15.42) feet in length, and four (4) feet in width for a total of sixty-one point six eight (61.68) square feet. Existing stair case is access to basement for building.

The location of said privilege shall be as shown on prints kept on file with the Department of Business Affairs and Consumer Protection and the Office of the City Clerk.

Said privilege shall be constructed in accordance with plans and specifications approved by the Department of Transportation (Division of Project Development).

This grant of privilege in the public way shall be subject to the provisions of Section 10-28-015 and all other required provisions of the Municipal Code of Chicago.

The grantee shall pay to the City of Chicago as compensation for the privilege #1112728 herein granted the sum of four hundred (\$400.00) per annum in advance.

A 25% penalty will be added for payments received after due date.

The permit holder agrees to hold the City of Chicago harmless for any damage, relocation or replacement costs associated with damage, relocation or removal of private property caused by the City performing work in the public way.

Authority herein given and granted for a period of five (5) years from and after Date of Passage.

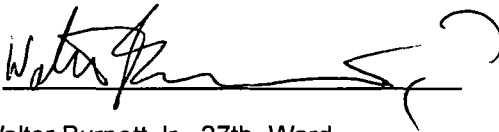
Alderman 
Walter Burnett Jr. 27th Ward

BAY
WINDOWS FIRE ESCAPE → COMING OFF

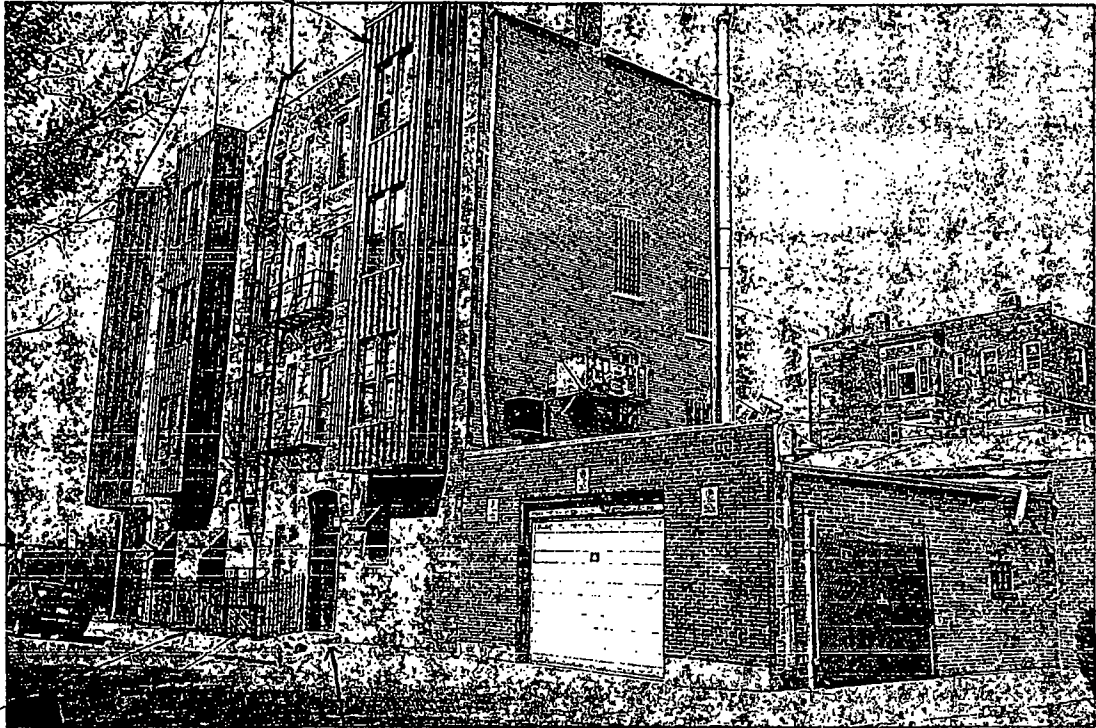

CANOPY
COMING
OFF

STAIRS
TO
BASEMENT

FENCE
FOR
STAIRS

STEP COMING OFF



MARKS
PEST CONTROL
MARTIN MACK
FIRE & SAFETY
EQUIPMENT

LEASE
OR SALE



City of Chicago



O2014-4449

Office of the City Clerk

Document Tracking Sheet

| | |
|---------------------------------|--|
| Meeting Date: | 5/28/2014 |
| Sponsor(s): | Burnett (27) |
| Type: | Ordinance |
| Title: | Grant(s) of privilege in public way for Westhaven Coin Laundry |
| Committee(s) Assignment: | Committee on Transportation and Public Way |

ORDINANCE
WESTHAVEN COIN LAUNDRY
Acct. No. 288228 - 2
Permit No. 1113075

Be It Ordained by the City Council of the City of Chicago:

SECTION 1. Permission and authority are hereby given and granted to WESTHAVEN COIN LAUNDRY, upon the terms and subject to the conditions of this ordinance to maintain and use one (1) sign(s) projecting over the public right-of-way attached to its premises known as 2355 W. Washington Blvd..

Said sign structure(s) measures as follows; along W. Washington:
One (1) at thirteen (13) feet in length, twelve point one seven (12.17) feet in height and twenty-three point one seven (23.17) feet above grade level.

The location of said privilege shall be as shown on prints kept on file with the Department of Business Affairs and Consumer Protection and the Office of the City Clerk

Said privilege shall be constructed in accordance with plans and specifications approved by the Department of Transportation (Division of Project Development) and Zoning Department- Signs.

This grant of privilege in the public way shall be subject to the provisions of Section 10-28-015 and all other required provisions of the Municipal Code of Chicago.

The grantee shall pay to the City of Chicago as compensation for the privilege #1113075 herein granted the sum of three hundred (\$300.00) per annum in advance.

A 25% penalty will be added for payments received after due date

The permit holder agrees to hold the City of Chicago harmless for any damage, relocation or replacement costs associated with damage, relocation or removal of private property caused by the City performing work in the public way.

Authority herein given and granted for a period offive (5) years from and after 12/17/2013.

Alderman

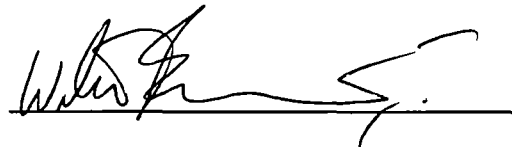

Walter Burnett Jr. 27th Ward

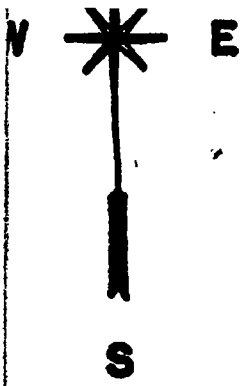

W. WASHINGTON

AVE.

N. WESTERN

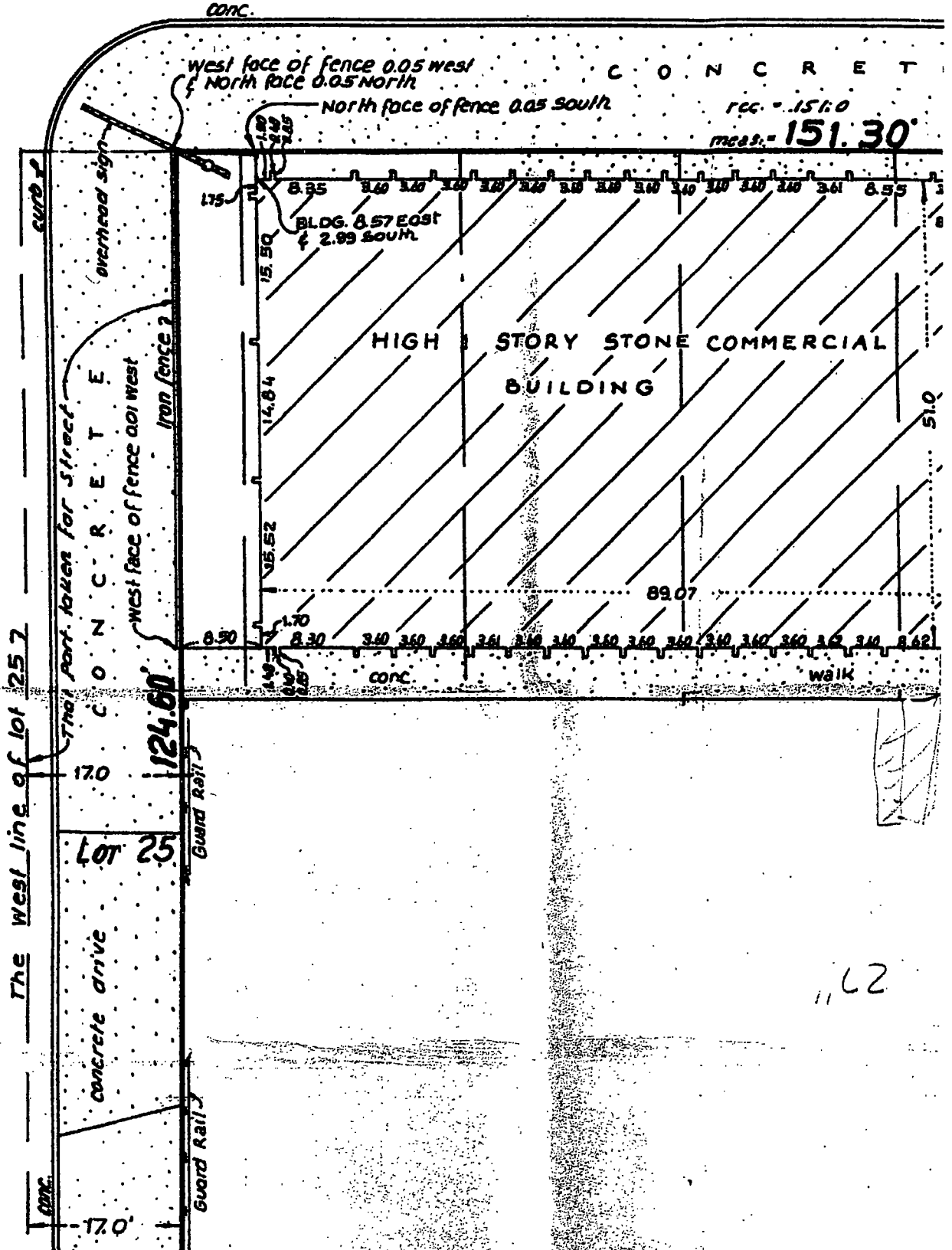

11,62



City of Chicago



O2014-4454

Office of the City Clerk

Document Tracking Sheet

| | |
|---------------------------------|--|
| Meeting Date: | 5/28/2014 |
| Sponsor(s): | Burnett (27) |
| Type: | Ordinance |
| Title: | Grant(s) of privilege in public way for 167 N May Street - Chris Livieratos |
| Committee(s) Assignment: | Committee on Transportation and Public Way |

ORDINANCE
167 N MAY STREET - CHRIS LIVIERATOS
Acct. No. 26385 - 2
Permit No. 1113083

Be It Ordained by the City Council of the City of Chicago:

SECTION 1. Permission and authority are hereby given and granted to 167 N MAY STREET - CHRIS LIVIERATOS, upon the terms and subject to the conditions of this ordinance to maintain and use, as now constructed, nine (9) Balcony(s) projecting over the public right-of-way adjacent to its premises known as 167 N. May St..

Said Balcony(s) at N. May Street measure(s):

Nine (9) at twelve point three three (12.33) feet in length, and three (3) feet in width for a total of three hundred thirty-two point nine one (332.91) square feet.

The location of said privilege shall be as shown on prints kept on file with the Department of Business Affairs and Consumer Protection and the Office of the City Clerk.

Said privilege shall be constructed in accordance with plans and specifications approved by the Department of Planning and Development and Department of Transportation (Division of Project Development).

This grant of privilege in the public way shall be subject to the provisions of Section 10-28-015 and all other required provisions of the Municipal Code of Chicago.

The grantee shall pay to the City of Chicago as compensation for the privilege #1113083 herein granted the sum of six hundred seventy-five (\$675.00) per annum in advance.

A 25% penalty will be added for payments received after due date.

The permit holder agrees to hold the City of Chicago harmless for any damage, relocation or replacement costs associated with damage, relocation or removal of private property caused by the City performing work in the public way.

Authority herein given and granted for a period of five (5) years from and after 02/11/2014.

Alderman 
Walter Burnett Jr. 27th Ward

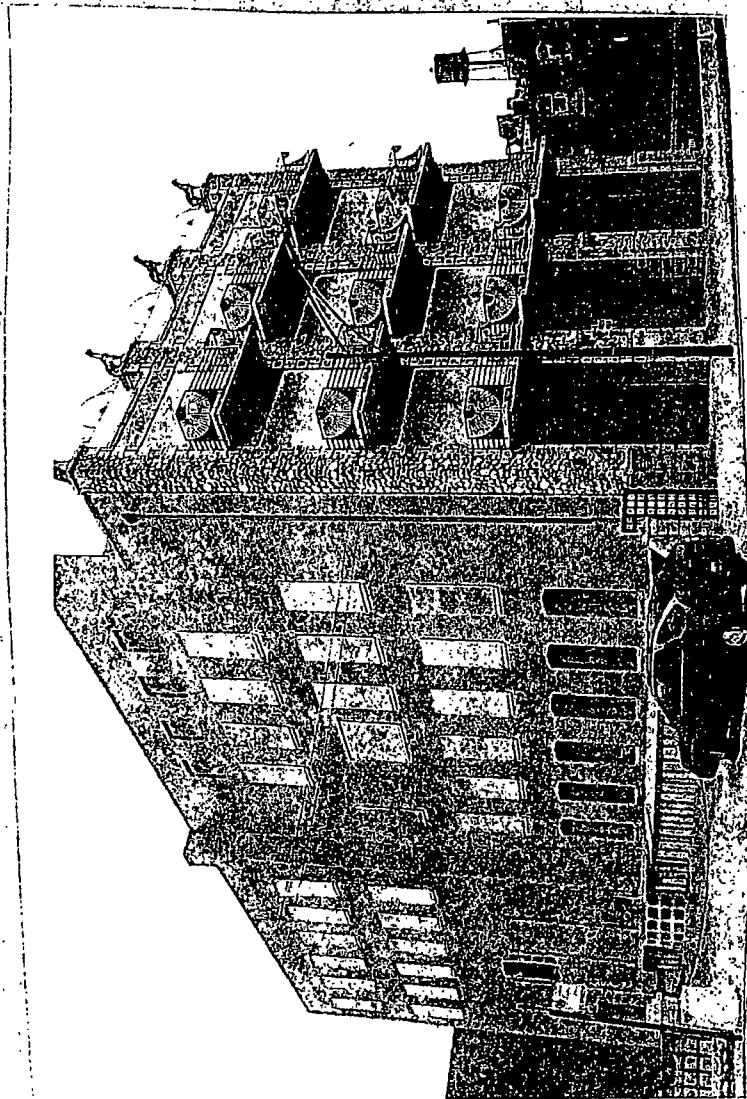



City of Chicago



O2014-4322

Office of the City Clerk

Document Tracking Sheet

| | |
|---------------------------------|--|
| Meeting Date: | 5/28/2014 |
| Sponsor(s): | Ervin (28) |
| Type: | Ordinance |
| Title: | Grant(s) of privilege in public way for Madison Street Gold Exchange, Inc. |
| Committee(s) Assignment: | Committee on Transportation and Public Way |

ORDINANCE
MADISON STREET GOLD EXCHANGE INC
Acct. No. 258870 - 2
Permit No. 1112801

Be It Ordained by the City Council of the City of Chicago:

SECTION 1. Permission and authority are hereby given and granted to MADISON STREET GOLD EXCHANGE INC, upon the terms and subject to the conditions of this ordinance to maintain and use one (1) sign(s) projecting over the public right-of-way attached to its premises known as 5134 W. Madison St..

Said sign structure(s) measures as follows; along W. Madison:
One (1) at eight (8) feet in length, eight (8) feet in height and sixteen point four one (16.41) feet above grade level.

The location of said privilege shall be as shown on prints kept on file with the Department of Business Affairs and Consumer Protection and the Office of the City Clerk.

Said privilege shall be constructed in accordance with plans and specifications approved by the Department of Transportation (Division of Project Development) and Zoning Department - Signs.

This grant of privilege in the public way shall be subject to the provisions of Section 10-28-015 and all other required provisions of the Municipal Code of Chicago.

The grantee shall pay to the City of Chicago as compensation for the privilege #1112801 herein granted the sum of three hundred (\$300.00) per annum in advance.

A 25% penalty will be added for payments received after due date.

The permit holder agrees to hold the City of Chicago harmless for any damage, relocation or replacement costs associated with damage, relocation or removal of private property caused by the City performing work in the public way.

Authority herein given and granted for a period of five (5) years from and after 04/09/2013.

Alderman _____

Jason Ervin 28th Ward





City of Chicago



O2014-4371

Office of the City Clerk
Document Tracking Sheet

| | |
|---------------------------------|--|
| Meeting Date: | 5/28/2014 |
| Sponsor(s): | Ervin (28) |
| Type: | Ordinance |
| Title: | Grant(s) of privilege in public way for Ogden, The |
| Committee(s) Assignment: | Committee on Transportation and Public Way |

ORDINANCE
THE OGDEN
Acct. No. 272662 - 1
Permit No. 1111666

Be It Ordained by the City Council of the City of Chicago:

SECTION 1. Permission and authority are hereby given and granted to THE OGDEN, upon the terms and subject to the conditions of this ordinance to maintain and use one (1) sign(s) projecting over the public right-of-way attached to its premises known as 1659 W. Ogden Ave..

Said sign structure(s) measures as follows; along W. Ogden Avenue:

One (1) at two point three three (2.33) feet in length, ten (10) feet in height and twelve (12) feet above grade level.

The location of said privilege shall be as shown on prints kept on file with the Department of Business Affairs and Consumer Protection and the Office of the City Clerk

Said privilege shall be constructed in accordance with plans and specifications approved by the Department of Transportation (Division of Project Development) and Zoning Department- Signs.

This grant of privilege in the public way shall be subject to the provisions of Section 10-28-015 and all other required provisions of the Municipal Code of Chicago.

The grantee shall pay to the City of Chicago as compensation for the privilege #1111666 herein granted the sum of one hundred (\$100.00) per annum in advance.

A 25% penalty will be added for payments received after due date

The permit holder agrees to hold the City of Chicago harmless for any damage, relocation or replacement costs associated with damage, relocation or removal of private property caused by the City performing work in the public way.

Authority herein given and granted for a period offive (5) years from and after Date of Passage.

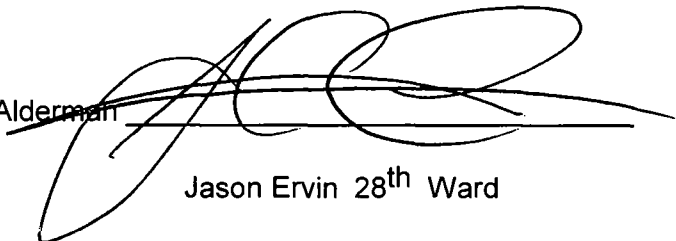
Alderman _____

Jason Ervin 28th Ward

Page 2

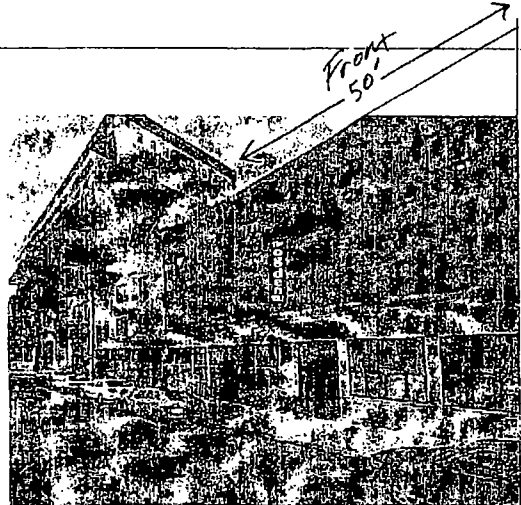
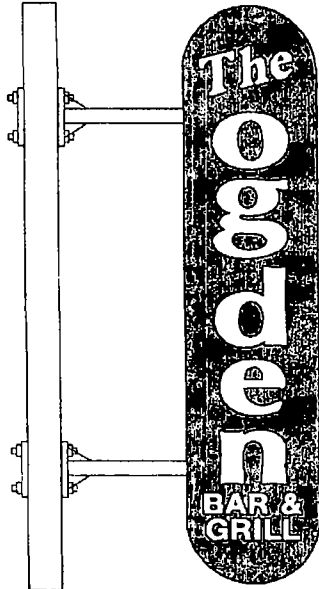
GUSSETS WELDED TO PIPE AND BACKING PLATE. THROUGH BOLTED WITH BACKING PLATES ON INSIDE AND OUTSIDE OF WALL



2'4" X 10' BLADE SIGN

12' TO GRADE

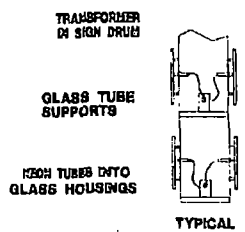

DOUBLE-FACE SIGN WITH SURFACE NEON CROSS SECTION

- 2" X 2" X 3/16" GALV. ANGLE IRON FRAME / WELDED
- 1 1/2" X 3/8" GALV. BOLTS
- .063 ALUMINUM FACES
- SECONDARY GROUND FAULT TRANSFORMERS
- 1/2" DRAIN HOLES
- DISCONNECT SWITCH
- U.L. APPROVED

Best Neon Sign

SCALE NO SCALE BY NO OGDEN6

CUSTOMER THE OGDEN

JOB ADDRESS 1858 W. OGDEN AVE.

CITY CHICAGO STATE IL

ARTIST IC DATE 2/28/14

SALES APPROVED DATE

CUSTOMER APPROVAL:

By signing the approval box on this sketch, I understand that I am accepting all aspects of this drawing. This includes artwork, specifications, dimensions, spelling and any other representations herein. I also understand that color representations on this sketch are approximations, and may not match manufactured product exactly.



City of Chicago



O2014-4380

Office of the City Clerk

Document Tracking Sheet

| | |
|---------------------------------|--|
| Meeting Date: | 5/28/2014 |
| Sponsor(s): | Ervin (28) |
| Type: | Ordinance |
| Title: | Grant(s) of privilege in public way for Polk & Western, Inc. |
| Committee(s) Assignment: | Committee on Transportation and Public Way |

ORDINANCE
POLK & WESTERN INC
Acct. No. 85822 - 2
Permit No. 1109933

Be It Ordained by the City Council of the City of Chicago:

SECTION 1. Permission and authority are hereby given and granted to POLK & WESTERN INC, upon the terms and subject to the conditions of this ordinance to maintain and use, as now constructed, one (1) Fire Shutter(s) projecting over the public right-of-way adjacent to its premises known as 749 S. Western Ave..

Said Fire Shutter(s) at S Western Ave measure(s):

One (1) at nineteen (19) feet in length, and one point one seven (1.17) foot in width for a total of twenty-two point two three (22.23) square feet.

The location of said privilege shall be as shown on prints kept on file with the Department of Business Affairs and Consumer Protection and the Office of the City Clerk.

Said privilege shall be constructed in accordance with plans and specifications approved by the Department of Transportation (Division of Project Development).

This grant of privilege in the public way shall be subject to the provisions of Section 10-28-015 and all other required provisions of the Municipal Code of Chicago.

The grantee shall pay to the City of Chicago as compensation for the privilege #1109933 herein granted the sum of four hundred (\$400.00) per annum in advance.

A 25% penalty will be added for payments received after due date.

The permit holder agrees to hold the City of Chicago harmless for any damage, relocation or replacement costs associated with damage, relocation or removal of private property caused by the City performing work in the public way.

Authority herein given and granted for a period of five (5) years from and after 11/05/2013.

Alderman _____

Jason Ervin 28th Ward

Plk + western Hut Dog
749 S. western Ave
(Fire Door)
Shutter



Length Along Public way
19 Feet



8 FT. 8 inches
HEIGHT FROM GRADE

Ground level

Depth of
canopy over
Public way

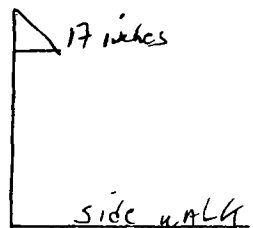



City of Chicago



O2014-4465

Office of the City Clerk

Document Tracking Sheet

| | |
|---------------------------------|---|
| Meeting Date: | 5/28/2014 |
| Sponsor(s): | Graham (29) |
| Type: | Ordinance |
| Title: | Grant(s) of privilege in public way for Angelo's Quick Stop |
| Committee(s) Assignment: | Committee on Transportation and Public Way |

ORDINANCE
ANGELO'S QUICK STOP
Acct. No. 323515 - 1
Permit No. 1113040

Be It Ordained by the City Council of the City of Chicago:

SECTION 1. Permission and authority are hereby given and granted to ANGELO'S QUICK STOP, upon the terms and subject to the conditions of this ordinance to maintain and use one (1) sign(s) projecting over the public right-of-way attached to its premises known as 6336 W. Grand Ave..

Said sign structure(s) measures as follows; along W Grand Ave:
One (1) at eight (8) feet in length, ten (10) feet in height and fifteen (15) feet above grade level.

The location of said privilege shall be as shown on prints kept on file with the Department of Business Affairs and Consumer Protection and the Office of the City Clerk.

Said privilege shall be constructed in accordance with plans and specifications approved by the Department of Transportation (Division of Project Development) and Zoning Department - Signs.

This grant of privilege in the public way shall be subject to the provisions of Section 10-28-015 and all other required provisions of the Municipal Code of Chicago.

The grantee shall pay to the City of Chicago as compensation for the privilege #1113040 herein granted the sum of three hundred (\$300.00) per annum in advance.

A 25% penalty will be added for payments received after due date.

The permit holder agrees to hold the City of Chicago harmless for any damage, relocation or replacement costs associated with damage, relocation or removal of private property caused by the City performing work in the public way.

Authority herein given and granted for a period of five (5) years from and after 01/13/2014.

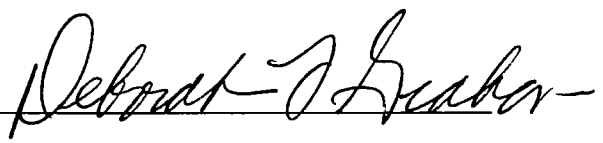
Alderman 
Deborah Graham 29th Ward



1-13-78
 2-13-78

1-13-78
 2-13-78

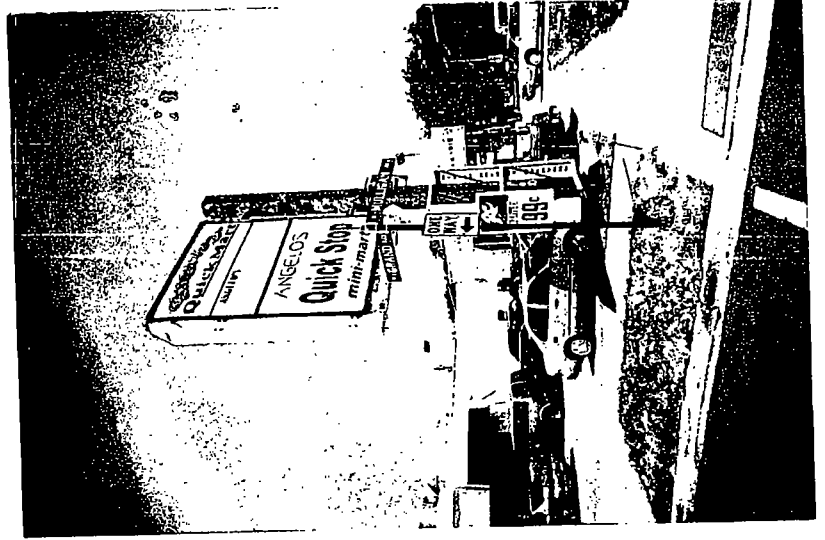

1-13-78
 2-13-78

1-13-78
 2-13-78



05/28/2014

Alderman **Deborah Graham**
Ward # **29**
City of Chicago
City Hall, Room **300**
121 North LaSalle Street
Chicago, Illinois 60602

Re: An ordinance to use and maintain a portion of the public right-of-way for **one (1) sign(s)** for **ANGELO'S QUICK STOP**, adjacent to the premises known as **6336 W. Grand Ave.**.

Dear Alderman **Deborah Graham**:

The applicant referenced above has requested the use of the public right-of-way for a **sign(s)**. An ordinance has been prepared by the Department of Business Affairs and Consumer Protection – Small Business Center - Public Way Use Unit for presentation to the City Council. Because this request was made for properties located in your ward, as approved by you as per the attached, I respectfully request that you introduce the attached ordinance at the next City Council meeting.

If you have any questions regarding this ordinance, please contact Anthony Bertuca at (312) 744-5506.

Department of Business Affairs and Consumer Protection



City of Chicago



O2014-4467

Office of the City Clerk

Document Tracking Sheet

| | |
|---------------------------------|--|
| Meeting Date: | 5/28/2014 |
| Sponsor(s): | Graham (29) |
| Type: | Ordinance |
| Title: | Grant(s) of privilege in public way for Barney's Pizza |
| Committee(s) Assignment: | Committee on Transportation and Public Way |

ORDINANCE
BARNEY'S PIZZA
Acct. No. 59800 - 4
Permit No. 1111979

Be It Ordained by the City Council of the City of Chicago:

SECTION 1. Permission and authority are hereby given and granted to BARNEY'S PIZZA, upon the terms and subject to the conditions of this ordinance to maintain and use one (1) sign(s) projecting over the public right-of-way attached to its premises known as 5648 W. Chicago Ave..

Said sign structure(s) measures as follows; along W. Chicago Avenue:

One (1) at ten point six seven (10.67) feet in length, six point six seven (6.67) feet in height and eleven (11) feet above grade level.

The location of said privilege shall be as shown on prints kept on file with the Department of Business Affairs and Consumer Protection and the Office of the City Clerk.

Said privilege shall be constructed in accordance with plans and specifications approved by the Department of Transportation (Division of Project Development) and Zoning Department - Signs.

This grant of privilege in the public way shall be subject to the provisions of Section 10-28-015 and all other required provisions of the Municipal Code of Chicago.

The grantee shall pay to the City of Chicago as compensation for the privilege #1111979 herein granted the sum of three hundred (\$300.00) per annum in advance.

A 25% penalty will be added for payments received after due date.

The permit holder agrees to hold the City of Chicago harmless for any damage, relocation or replacement costs associated with damage, relocation or removal of private property caused by the City performing work in the public way.

Authority herein given and granted for a period of five (5) years from and after Date of Passage.

Alderman

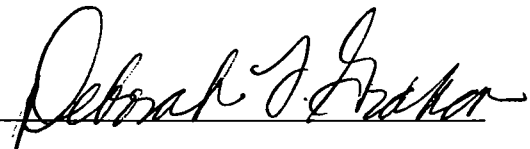

Deborah Graham 29th Ward



Ad Deluxe Sign Co.
23856 WEST ANDREW ROAD
SUITE 103
PLAINFIELD, IL 60585
ADELUXESIGN@comcast.net
phone : 815-556-8469
phone: 815-782-7048
fax: 815-782-7760



05/28/2014

Alderman **Deborah Graham**
Ward # **29**
City of Chicago
City Hall, Room **300**
121 North LaSalle Street
Chicago, Illinois 60602

Re: An ordinance to use and maintain a portion of the public right-of-way for **one (1) sign(s)** for **BARNEY'S PIZZA**, adjacent to the premises known as **5648 W. Chicago Ave.**.

Dear Alderman **Deborah Graham**:

The applicant referenced above has requested the use of the public right-of-way for a **sign(s)**. An ordinance has been prepared by the Department of Business Affairs and Consumer Protection – Small Business Center - Public Way Use Unit for presentation to the City Council. Because this request was made for properties located in your ward, as approved by you as per the attached, I respectfully request that you introduce the attached ordinance at the next City Council meeting.

If you have any questions regarding this ordinance, please contact Anthony Bertuca at (312) 744-5506.

Department of Business Affairs and Consumer Protection



City of Chicago



O2014-4472

Office of the City Clerk

Document Tracking Sheet

| | |
|---------------------------------|---|
| Meeting Date: | 5/28/2014 |
| Sponsor(s): | Reboyras (30) |
| Type: | Ordinance |
| Title: | Grant(s) of privilege in public way for Advantage MRI |
| Committee(s) Assignment: | Committee on Transportation and Public Way |

ORDINANCE
ADVANTAGE MRI
Acct. No. 310227 - 1
Permit No. 1113119

Be It Ordained by the City Council of the City of Chicago:

SECTION 1. Permission and authority are hereby given and granted to ADVANTAGE MRI, upon the terms and subject to the conditions of this ordinance to maintain and use one (1) sign(s) projecting over the public right-of-way attached to its premises known as 2008 N. Pulaski Rd..

Said sign structure(s) measures as follows; along n. pulaski:
One (1) at four (4) feet in length, eight (8) feet in height and nine point four two (9.42) feet above grade level.

The location of said privilege shall be as shown on prints kept on file with the Department of Business Affairs and Consumer Protection and the Office of the City Clerk.

Said privilege shall be constructed in accordance with plans and specifications approved by the Department of Transportation (Division of Project Development) and Zoning Department - Signs.

This grant of privilege in the public way shall be subject to the provisions of Section 10-28-015 and all other required provisions of the Municipal Code of Chicago.

The grantee shall pay to the City of Chicago as compensation for the privilege #1113119 herein granted the sum of three hundred (\$300.00) per annum in advance.

A 25% penalty will be added for payments received after due date.

The permit holder agrees to hold the City of Chicago harmless for any damage, relocation or replacement costs associated with damage, relocation or removal of private property caused by the City performing work in the public way.

Authority herein given and granted for a period of five (5) years from and after 06/11/2013.

Alderman _____

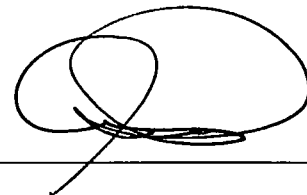

Ariel Reboyras 30th Ward

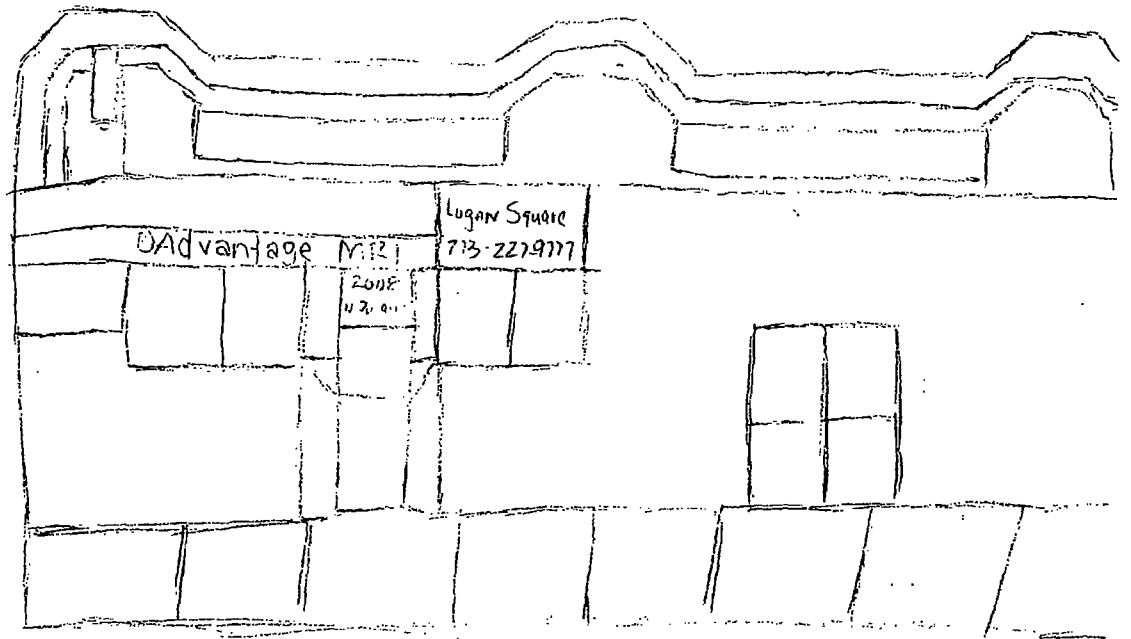



05/28/2014

Alderman **Ariel Reboyras**
Ward # **30**
City of Chicago
City Hall, Room **203**
121 North LaSalle Street
Chicago, Illinois 60602

Re: An ordinance to use and maintain a portion of the public right-of-way for **one (1) sign(s)** for **ADVANTAGE MRI**, adjacent to the premises known as **2008 N. Pulaski Rd.**.

Dear Alderman **Ariel Reboyras**:

The applicant referenced above has requested the use of the public right-of-way for a **sign(s)**. An ordinance has been prepared by the Department of Business Affairs and Consumer Protection -- Small Business Center - Public Way Use Unit for presentation to the City Council. Because this request was made for properties located in your ward, as approved by you as per the attached, I respectfully request that you introduce the attached ordinance at the next City Council meeting.

If you have any questions regarding this ordinance, please contact Anthony Bertuca at (312) 744-5506.

Department of Business Affairs and Consumer Protection



City of Chicago



O2014-4475

Office of the City Clerk

Document Tracking Sheet

| | |
|---------------------------------|---|
| Meeting Date: | 5/28/2014 |
| Sponsor(s): | Reboyras (30) |
| Type: | Ordinance |
| Title: | Grant(s) of privilege in public way for Bristol Liquors, Inc. |
| Committee(s) Assignment: | Committee on Transportation and Public Way |

ORDINANCE
BRISTOL LIQUORS INC
Acct. No. 11140 - 1
Permit No. 1112928

Be It Ordained by the City Council of the City of Chicago:

SECTION 1. Permission and authority are hereby given and granted to BRISTOL LIQUORS INC, upon the terms and subject to the conditions of this ordinance to maintain and use two (2) sign(s) projecting over the public right-of-way attached to its premises known as 5207 W. Belmont Ave..

Said sign structure(s) measures as follows; along W. Belmont:

One (1) at four (4) feet in length, eight (8) feet in height and fourteen (14) feet above grade level.

One (1) at eight (8) feet in length, twelve (12) feet in height and fourteen (14) feet above grade level.

The location of said privilege shall be as shown on prints kept on file with the Department of Business Affairs and Consumer Protection and the Office of the City Clerk.

Said privilege shall be constructed in accordance with plans and specifications approved by the Department of Transportation (Division of Project Development) and Zoning Department - Signs.

This grant of privilege in the public way shall be subject to the provisions of Section 10-28-015 and all other required provisions of the Municipal Code of Chicago.

The grantee shall pay to the City of Chicago as compensation for the privilege #1112928 herein granted the sum of six hundred (\$600.00) per annum in advance.

A 25% penalty will be added for payments received after due date.

The permit holder agrees to hold the City of Chicago harmless for any damage, relocation or replacement costs associated with damage, relocation or removal of private property caused by the City performing work in the public way.

Authority herein given and granted for a period of five (5) years from and after 11/19/2013.

Alderman _____



Ariel Reboyras 30th Ward

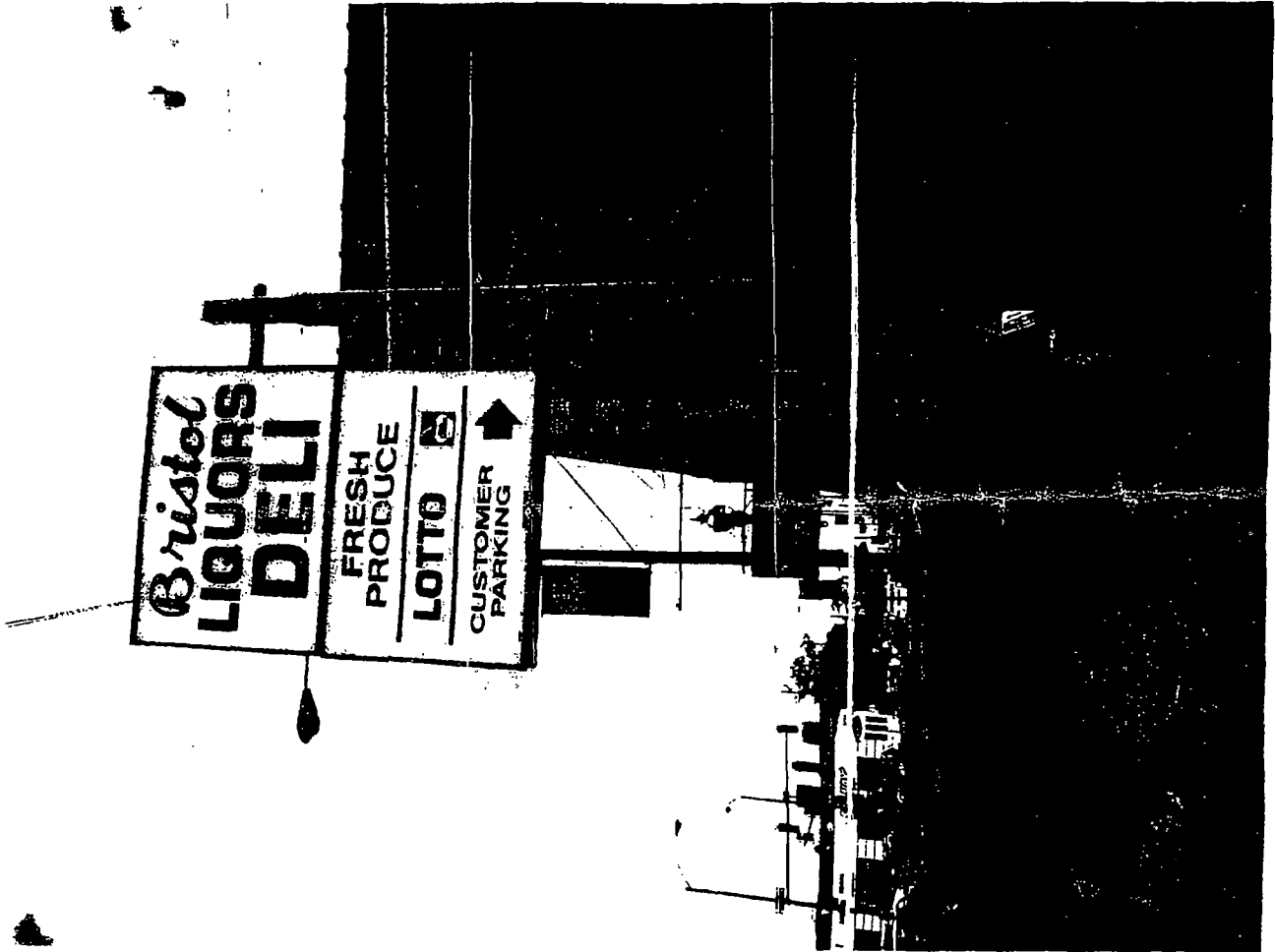

8'
X
12'

14'
FROM SIDEWALK
TO SIGN

SIDEWALK IS 8' WIDE
150' TO NEAREST INTERSECTION
(LARAMIE)



05/28/2014

Alderman **Ariel Reboyras**
Ward # **30**
City of Chicago
City Hall, Room **203**
121 North LaSalle Street
Chicago, Illinois 60602

Re: An ordinance to use and maintain a portion of the public right-of-way for **two (2) sign(s)** for
BRISTOL LIQUORS INC, adjacent to the premises known as **5207 W. Belmont Ave.**.

Dear Alderman **Ariel Reboyras**:

The applicant referenced above has requested the use of the public right-of-way for a **sign(s)**. An ordinance has been prepared by the Department of Business Affairs and Consumer Protection – Small Business Center - Public Way Use Unit for presentation to the City Council. Because this request was made for properties located in your ward, as approved by you as per the attached, I respectfully request that you introduce the attached ordinance at the next City Council meeting.

If you have any questions regarding this ordinance, please contact Anthony Bertuca at (312) 744-5506.

Department of Business Affairs and Consumer Protection



City of Chicago



O2014-4478

Office of the City Clerk

Document Tracking Sheet

| | |
|---------------------------------|---|
| Meeting Date: | 5/28/2014 |
| Sponsor(s): | Reboyras (30) |
| Type: | Ordinance |
| Title: | Grant(s) of privilege in public way for EM Lounge |
| Committee(s) Assignment: | Committee on Transportation and Public Way |

ORDINANCE
EM LOUNGE
Acct. No. 328528 - 1
Permit No. 1113074

Be It Ordained by the City Council of the City of Chicago:

SECTION 1. Permission and authority are hereby given and granted to EM LOUNGE, upon the terms and subject to the conditions of this ordinance to maintain and use one (1) sign(s) projecting over the public right-of-way attached to its premises known as 4247 W. Armitage Ave..

Said sign structure(s) measures as follows; along W ARMITAGE AVE:
One (1) at six (6) feet in length, three point five (3.5) feet in height and fifteen (15) feet above grade level.

The location of said privilege shall be as shown on prints kept on file with the Department of Business Affairs and Consumer Protection and the Office of the City Clerk.

Said privilege shall be constructed in accordance with plans and specifications approved by the Department of Transportation (Division of Project Development) and Zoning Department - Signs.

This grant of privilege in the public way shall be subject to the provisions of Section 10-28-015 and all other required provisions of the Municipal Code of Chicago.

The grantee shall pay to the City of Chicago as compensation for the privilege #1113074 herein granted the sum of one hundred (\$100.00) per annum in advance.

A 25% penalty will be added for payments received after due date.

The permit holder agrees to hold the City of Chicago harmless for any damage, relocation or replacement costs associated with damage, relocation or removal of private property caused by the City performing work in the public way.

Authority herein given and granted for a period of five (5) years from and after 04/22/2014.

Alderman _____



Ariel Reboyras 30th Ward

Wednesday, April 23, 2014
10:59 AM





05/28/2014

Alderman **Ariel Reboyras**
Ward # **30**
City of Chicago
City Hall, Room **203**
121 North LaSalle Street
Chicago, Illinois 60602

Re: An ordinance to use and maintain a portion of the public right-of-way for **one (1) sign(s)** for **EM LOUNGE**, adjacent to the premises known as **4247 W. Armitage Ave.**.

Dear Alderman **Ariel Reboyras**:

The applicant referenced above has requested the use of the public right-of-way for a **sign(s)**. An ordinance has been prepared by the Department of Business Affairs and Consumer Protection – Small Business Center - Public Way Use Unit for presentation to the City Council. Because this request was made for properties located in your ward, as approved by you as per the attached, I respectfully request that you introduce the attached ordinance at the next City Council meeting.

If you have any questions regarding this ordinance, please contact Anthony Bertuca at (312) 744-5506.

Department of Business Affairs and Consumer Protection



City of Chicago



O2014-4480

Office of the City Clerk

Document Tracking Sheet

| | |
|---------------------------------|--|
| Meeting Date: | 5/28/2014 |
| Sponsor(s): | Reboyras (30) |
| Type: | Ordinance |
| Title: | Grant(s) of privilege in public way for Podlasie |
| Committee(s) Assignment: | Committee on Transportation and Public Way |

ORDINANCE
PODLASIE
Acct. No. 26176 - 1
Permit No. 1113018

Be It Ordained by the City Council of the City of Chicago:

SECTION 1. Permission and authority are hereby given and granted to PODLASIE, upon the terms and subject to the conditions of this ordinance to maintain and use one (1) sign(s) projecting over the public right-of-way attached to its premises known as 2918 N. Central Park Ave..

Said sign structure(s) measures as follows; along N CENTRAL PARK AVE:
One (1) at eight point three three (8.33) feet in length, four point one seven (4.17) feet in height and fifteen point six seven (15.67) feet above grade level.

The location of said privilege shall be as shown on prints kept on file with the Department of Business Affairs and Consumer Protection and the Office of the City Clerk.

Said privilege shall be constructed in accordance with plans and specifications approved by the Department of Transportation (Division of Project Development) and Zoning Department - Signs.

This grant of privilege in the public way shall be subject to the provisions of Section 10-28-015 and all other required provisions of the Municipal Code of Chicago.

The grantee shall pay to the City of Chicago as compensation for the privilege #1113018 herein granted the sum of three hundred (\$300.00) per annum in advance.

A 25% penalty will be added for payments received after due date.

The permit holder agrees to hold the City of Chicago harmless for any damage, relocation or replacement costs associated with damage, relocation or removal of private property caused by the City performing work in the public way.

Authority herein given and granted for a period of five (5) years from and after 05/13/2014.

Alderman _____

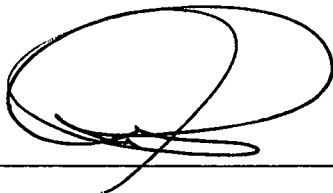

Ariel Reboyras 30th Ward

2929 North Central Park Avenue - Google Maps

Page 1 of 1

Google

2918
Address ~~2929~~ North Central Park Avenue
Address is approximate





Department of Business Affairs and Consumer Protection
Small Business Center - Public Way Use Unit
City Hall - 121 N. LaSalle Street, Room 800 • Chicago, IL 60602
(312)-74-GOBIZ (312-744-6249) • (312) 744-1944 (TTY)
<http://www.cityofchicago.org/bacp>

05/28/2014

Alderman **Ariel Reboyras**
Ward # 30
City of Chicago
City Hall, Room 203
121 North LaSalle Street
Chicago, Illinois 60602

Re: An ordinance to use and maintain a portion of the public right-of-way for **one (1) sign(s)** for **PODLASIE**, adjacent to the premises known as **2918 N. Central Park Ave.**.

Dear Alderman **Ariel Reboyras**:

The applicant referenced above has requested the use of the public right-of-way for a **sign(s)**. An ordinance has been prepared by the Department of Business Affairs and Consumer Protection – Small Business Center - Public Way Use Unit for presentation to the City Council. Because this request was made for properties located in your ward, as approved by you as per the attached, I respectfully request that you introduce the attached ordinance at the next City Council meeting.

If you have any questions regarding this ordinance, please contact Anthony Bertuca at (312) 744-5506.

Department of Business Affairs and Consumer Protection



City of Chicago



O2014-4486

Office of the City Clerk

Document Tracking Sheet

| | |
|---------------------------------|---|
| Meeting Date: | 5/28/2014 |
| Sponsor(s): | Reboyas (30) |
| Type: | Ordinance |
| Title: | Grant(s) of privilege in public way for Taqueria La Oaxaquena |
| Committee(s) Assignment: | Committee on Transportation and Public Way |

ORDINANCE
TAQUERIA LA OAXAQUENA
Acct. No. 49411 - 1
Permit No. 1113124

Be It Ordained by the City Council of the City of Chicago:

SECTION 1. Permission and authority are hereby given and granted to TAQUERIA LA OAXAQUENA, upon the terms and subject to the conditions of this ordinance to maintain and use one (1) sign(s) projecting over the public right-of-way attached to its premises known as 3382 N. Milwaukee Ave..

Said sign structure(s) measures as follows; along NORTH MILWAUKEE:
One (1) at six point one (6.1) feet in length, two point six seven (2.67) feet in height and fourteen (14) feet above grade level.

The location of said privilege shall be as shown on prints kept on file with the Department of Business Affairs and Consumer Protection and the Office of the City Clerk.

Said privilege shall be constructed in accordance with plans and specifications approved by the Department of Transportation (Division of Project Development) and Zoning Department - Signs.

This grant of privilege in the public way shall be subject to the provisions of Section 10-28-015 and all other required provisions of the Municipal Code of Chicago.

The grantee shall pay to the City of Chicago as compensation for the privilege #1113124 herein granted the sum of one hundred (\$100.00) per annum in advance.

A 25% penalty will be added for payments received after due date.

The permit holder agrees to hold the City of Chicago harmless for any damage, relocation or replacement costs associated with damage, relocation or removal of private property caused by the City performing work in the public way.

Authority herein given and granted for a period of five (5) years from and after 05/09/2012.

Alderman _____

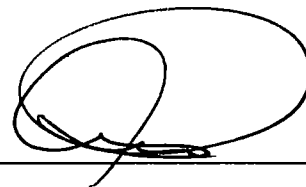

Ariel Reboyras 30th Ward

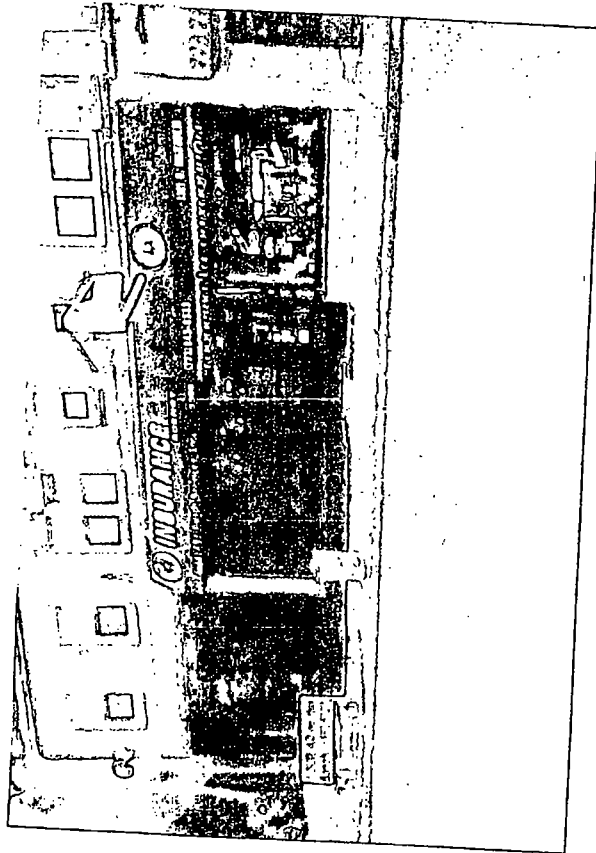



05/28/2014

Alderman **Ariel Reboyras**
Ward # **30**
City of Chicago
City Hall, Room **203**
121 North LaSalle Street
Chicago, Illinois 60602

Re: An ordinance to use and maintain a portion of the public right-of-way for **one (1) sign(s)** for
TAQUERIA LA OAXAQUENA, adjacent to the premises known as **3382 N. Milwaukee Ave.**.

Dear Alderman **Ariel Reboyras**:

The applicant referenced above has requested the use of the public right-of-way for a **sign(s)**. An ordinance has been prepared by the Department of Business Affairs and Consumer Protection – Small Business Center - Public Way Use Unit for presentation to the City Council. Because this request was made for properties located in your ward, as approved by you as per the attached, I respectfully request that you introduce the attached ordinance at the next City Council meeting.

If you have any questions regarding this ordinance, please contact Anthony Bertuca at (312) 744-5506.

Department of Business Affairs and Consumer Protection



City of Chicago



O2014-4490

Office of the City Clerk

Document Tracking Sheet

| | |
|---------------------------------|---|
| Meeting Date: | 5/28/2014 |
| Sponsor(s): | Suarez (31) |
| Type: | Ordinance |
| Title: | Grant(s) of privilege in public way for Advanced Medical Clinic |
| Committee(s) Assignment: | Committee on Transportation and Public Way |

ORDINANCE
ADVANCED MEDICAL CLINIC
Acct. No. 388375 - 1
Permit No. 1111254

Be It Ordained by the City Council of the City of Chicago:

SECTION 1. Permission and authority are hereby given and granted to ADVANCED MEDICAL CLINIC, upon the terms and subject to the conditions of this ordinance to maintain and use two (2) sign(s) projecting over the public right-of-way attached to its premises known as 4009 W. Fullerton Ave..

Said sign structure(s) measures as follows; along W. Fullerton Avenue:
One (1) at eight (8) feet in length, five (5) feet in height and ten (10) feet above grade level.

Said sign structure(s) measures as follows; along W. Fullerton Avenue:
One (1) at eight (8) feet in length, five (5) feet in height and ten (10) feet above grade level.

The location of said privilege shall be as shown on prints kept on file with the Department of Business Affairs and Consumer Protection and the Office of the City Clerk.

Said privilege shall be constructed in accordance with plans and specifications approved by the Department of Transportation (Division of Project Development) and Zoning Department - Signs.

This grant of privilege in the public way shall be subject to the provisions of Section 10-28-015 and all other required provisions of the Municipal Code of Chicago.

The grantee shall pay to the City of Chicago as compensation for the privilege #1111254 herein granted the sum of six hundred (\$600.00) per annum in advance.

A 25% penalty will be added for payments received after due date.

The permit holder agrees to hold the City of Chicago harmless for any damage, relocation or replacement costs associated with damage, relocation or removal of private property caused by the City performing work in the public way.

Authority herein given and granted for a period of five (5) years from and after Date of Passage.

Alderman

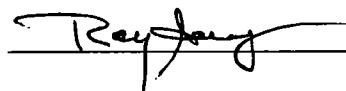

Ray Suarez 31st Ward



APPLICATION TO USE THE PUBLIC RIGHT OF WAY

EXAMPLE OF SIGN DRAWING

Pole Sign

SIGN DRAWING

PROPERTY LOCATION: HOOVER WEST FULLERTON
ORGANIZATION(S) NAME: ADVANCED MEDICAL CLINIC

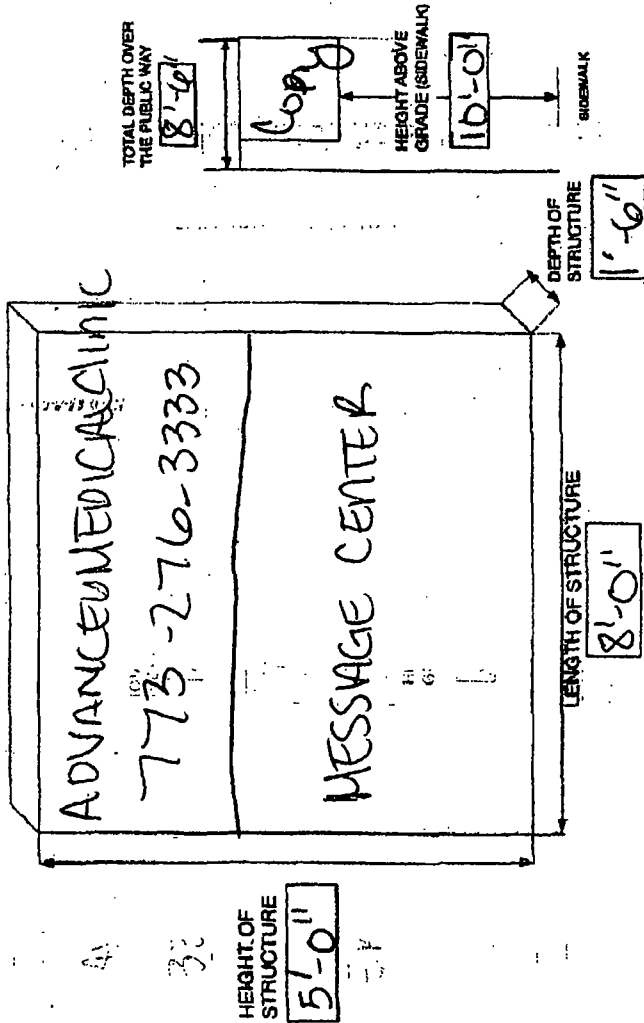



05/28/2014

Alderman **Ray Suarez**
Ward # **31**
City of Chicago
City Hall, Room **203**
121 North LaSalle Street
Chicago, Illinois 60602

Re: An ordinance to use and maintain a portion of the public right-of-way for **two (2) sign(s)** for
ADVANCED MEDICAL CLINIC, adjacent to the premises known as **4009 W. Fullerton Ave.**

Dear Alderman **Ray Suarez**:

The applicant referenced above has requested the use of the public right-of-way for a **sign(s)**. An ordinance has been prepared by the Department of Business Affairs and Consumer Protection – Small Business Center - Public Way Use Unit for presentation to the City Council. Because this request was made for properties located in your ward, as approved by you as per the attached, I respectfully request that you introduce the attached ordinance at the next City Council meeting.

If you have any questions regarding this ordinance, please contact Anthony Bertuca at (312) 744-5506.

Department of Business Affairs and Consumer Protection



City of Chicago



O2014-4494

Office of the City Clerk

Document Tracking Sheet

| | |
|---------------------------------|---|
| Meeting Date: | 5/28/2014 |
| Sponsor(s): | Suarez (31) |
| Type: | Ordinance |
| Title: | Grant(s) of privilege in public way for Baskin Robbins/Dunkin Donuts |
| Committee(s) Assignment: | Committee on Transportation and Public Way |

ORDINANCE
BASKIN ROBBINS/ DUNKIN DONUTS
Acct. No. 16603 - 1
Permit No. 1112724

Be It Ordained by the City Council of the City of Chicago:

SECTION 1. Permission and authority are hereby given and granted to BASKIN ROBBINS/ DUNKIN DONUTS, upon the terms and subject to the conditions of this ordinance to maintain and use one (1) sign(s) projecting over the public right-of-way attached to its premises known as 3039 N. Central Ave..

Said sign structure(s) measures as follows; along N. Central Avenue:
One (1) at twelve point one seven (12.17) feet in length, six point two five (6.25) feet in height and eighteen point five (18.5) feet above grade level.

The location of said privilege shall be as shown on prints kept on file with the Department of Business Affairs and Consumer Protection and the Office of the City Clerk.

Said privilege shall be constructed in accordance with plans and specifications approved by the Department of Transportation (Division of Project Development) and Zoning Department - Signs.

This grant of privilege in the public way shall be subject to the provisions of Section 10-28-015 and all other required provisions of the Municipal Code of Chicago.

The grantee shall pay to the City of Chicago as compensation for the privilege #1112724 herein granted the sum of three hundred (\$300.00) per annum in advance.

A 25% penalty will be added for payments received after due date.

The permit holder agrees to hold the City of Chicago harmless for any damage, relocation or replacement costs associated with damage, relocation or removal of private property caused by the City performing work in the public way.

Authority herein given and granted for a period of five (5) years from and after 10/31/2012.

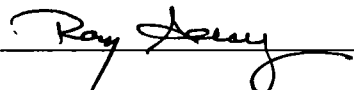
Alderman 
Ray Suarez 31st Ward

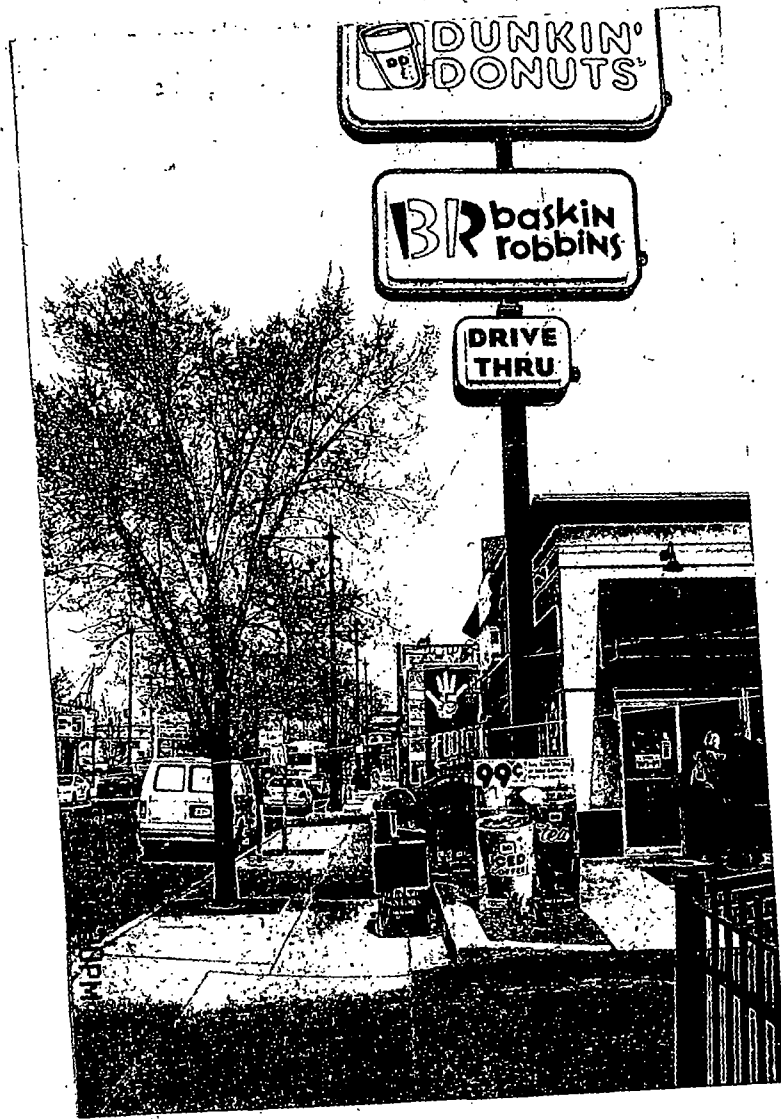



05/28/2014

Alderman **Ray Suarez**
Ward # **31**
City of Chicago
City Hall, Room **203**
121 North LaSalle Street
Chicago, Illinois 60602

Re: An ordinance to use and maintain a portion of the public right-of-way for **one (1) sign(s)** for **BASKIN ROBBINS/ DUNKIN DONUTS**, adjacent to the premises known as **3039 N. Central Ave.**.

Dear Alderman **Ray Suarez**:

The applicant referenced above has requested the use of the public right-of-way for a **sign(s)**. An ordinance has been prepared by the Department of Business Affairs and Consumer Protection – Small Business Center - Public Way Use Unit for presentation to the City Council. Because this request was made for properties located in your ward, as approved by you as per the attached, I respectfully request that you introduce the attached ordinance at the next City Council meeting.

If you have any questions regarding this ordinance, please contact Anthony Bertuca at (312) 744-5506.

Department of Business Affairs and Consumer Protection



City of Chicago



O2014-4496

Office of the City Clerk

Document Tracking Sheet

| | |
|---------------------------------|---|
| Meeting Date: | 5/28/2014 |
| Sponsor(s): | Suarez (31) |
| Type: | Ordinance |
| Title: | Grant(s) of privilege in public way for Salgado Furniture, Inc. |
| Committee(s) Assignment: | Committee on Transportation and Public Way |

ORDINANCE
SALGADO FURNITURE, INC.
Acct. No. 289717 - 1
Permit No. 1113045

Be It Ordained by the City Council of the City of Chicago:

SECTION 1. Permission and authority are hereby given and granted to SALGADO FURNITURE, INC., upon the terms and subject to the conditions of this ordinance to maintain and use two (2) sign(s) projecting over the public right-of-way attached to its premises known as 4317-25 W. Fullerton Ave..

Said sign structure(s) measures as follows; along W. Fullerton:

One (1) at five (5) feet in length, four (4) feet in height and sixteen (16) feet above grade level.

One (1) at five point eight three (5.83) feet in length, four (4) feet in height and twenty-four (24) feet above grade level.

The location of said privilege shall be as shown on prints kept on file with the Department of Business Affairs and Consumer Protection and the Office of the City Clerk.

Said privilege shall be constructed in accordance with plans and specifications approved by the Department of Transportation (Division of Project Development) and Zoning Department - Signs.

This grant of privilege in the public way shall be subject to the provisions of Section 10-28-015 and all other required provisions of the Municipal Code of Chicago.

The grantee shall pay to the City of Chicago as compensation for the privilege #1113045 herein granted the sum of one hundred seventy-five (\$175.00) per annum in advance.

A 25% penalty will be added for payments received after due date.

The permit holder agrees to hold the City of Chicago harmless for any damage, relocation or replacement costs associated with damage, relocation or removal of private property caused by the City performing work in the public way.

Authority herein given and granted for a period of five (5) years from and after 05/13/2014.

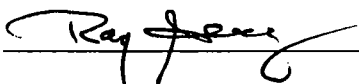
Alderman 
Ray Suarez 31st Ward

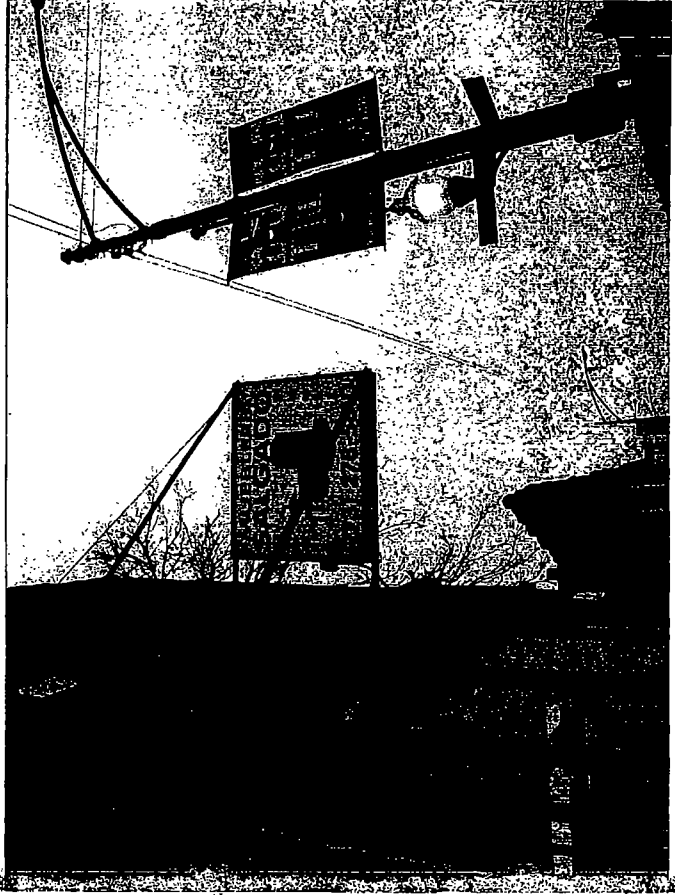



05/28/2014

Alderman **Ray Suarez**
Ward # **31**
City of Chicago
City Hall, Room **203**
121 North LaSalle Street
Chicago, Illinois 60602

Re: An ordinance to use and maintain a portion of the public right-of-way for **two (2) sign(s)** for
SALGADO FURNITURE, INC., adjacent to the premises known as **4317-25 W. Fullerton Ave.**.

Dear Alderman **Ray Suarez**:

The applicant referenced above has requested the use of the public right-of-way for a **sign(s)**. An ordinance has been prepared by the Department of Business Affairs and Consumer Protection – Small Business Center - Public Way Use Unit for presentation to the City Council. Because this request was made for properties located in your ward, as approved by you as per the attached, I respectfully request that you introduce the attached ordinance at the next City Council meeting.

If you have any questions regarding this ordinance, please contact Anthony Bertuca at (312) 744-5506.

Department of Business Affairs and Consumer Protection



City of Chicago



O2014-4502

Office of the City Clerk

Document Tracking Sheet

| | |
|---------------------------------|---|
| Meeting Date: | 5/28/2014 |
| Sponsor(s): | Waguespack (32) |
| Type: | Ordinance |
| Title: | Grant(s) of privilege in public way for Bluelight |
| Committee(s) Assignment: | Committee on Transportation and Public Way |

ORDINANCE
BLUELIGHT
Acct. No. 30953 - 1
Permit No. 1113021

Be It Ordained by the City Council of the City of Chicago:

SECTION 1. Permission and authority are hereby given and granted to BLUELIGHT, upon the terms and subject to the conditions of this ordinance to maintain and use one (1) sign(s) projecting over the public right-of-way attached to its premises known as 3251 N. Western Ave..

Said sign structure(s) measures as follows; along N Western Ave:

One (1) at four (4) feet in length, fifteen (15) feet in height and nine point two five (9.25) feet above grade level.

The location of said privilege shall be as shown on prints kept on file with the Department of Business Affairs and Consumer Protection and the Office of the City Clerk.

Said privilege shall be constructed in accordance with plans and specifications approved by the Department of Transportation (Division of Project Development) and Zoning Department - Signs.

This grant of privilege in the public way shall be subject to the provisions of Section 10-28-015 and all other required provisions of the Municipal Code of Chicago.

The grantee shall pay to the City of Chicago as compensation for the privilege #1113021 herein granted the sum of three hundred (\$300.00) per annum in advance.

A 25% penalty will be added for payments received after due date.

The permit holder agrees to hold the City of Chicago harmless for any damage, relocation or replacement costs associated with damage, relocation or removal of private property caused by the City performing work in the public way.

Authority herein given and granted for a period of five (5) years from and after 05/13/2014.

Alderman



Scott Waguespack 32nd Ward

Handwritten scribbles or marks at the bottom of the page.

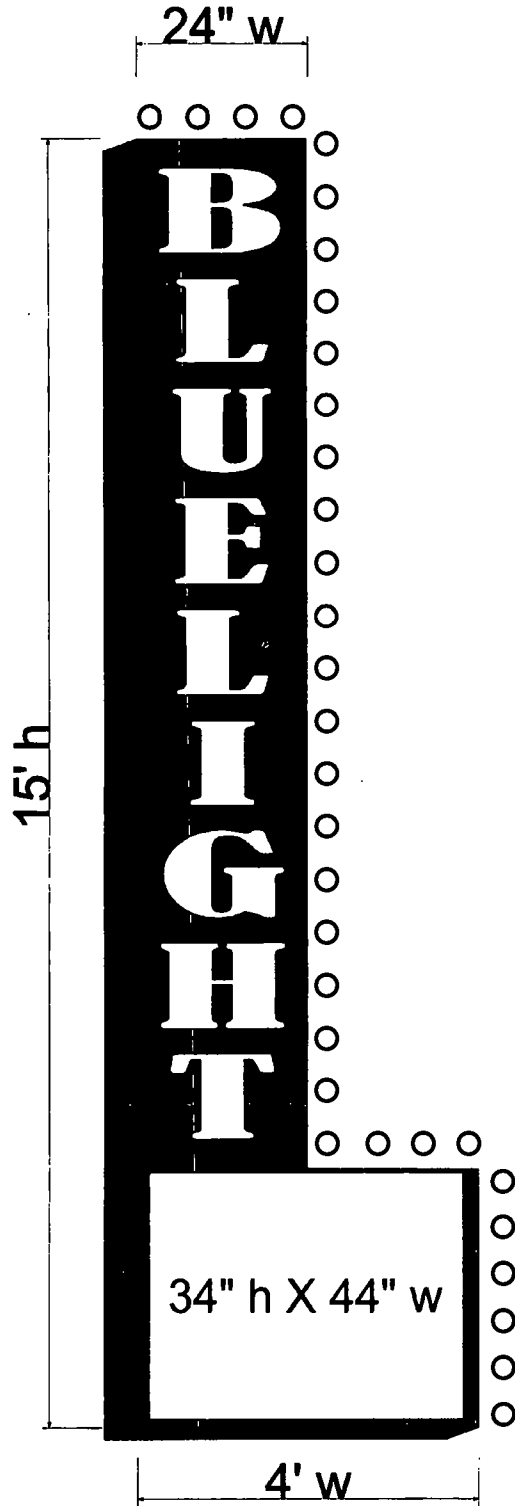



Department of Business Affairs and Consumer Protection
Small Business Center - Public Way Use Unit
City Hall - 121 N. LaSalle Street, Room 800 • Chicago, IL 60602
(312)-74-GOBIZ (312-744-6249) • (312) 744-1944 (TTY)
<http://www.cityofchicago.org/bacp>

05/28/2014

Alderman **Scott Waguespack**
Ward # **32**
City of Chicago
City Hall, Room **300**
121 North LaSalle Street
Chicago, Illinois 60602

Re: An ordinance to use and maintain a portion of the public right-of-way for **one (1) sign(s)** for **BLUELIGHT**, adjacent to the premises known as **3251 N. Western Ave.**.

Dear Alderman **Scott Waguespack**:

The applicant referenced above has requested the use of the public right-of-way for a **sign(s)**. An ordinance has been prepared by the Department of Business Affairs and Consumer Protection -- Small Business Center - Public Way Use Unit for presentation to the City Council. Because this request was made for properties located in your ward, as approved by you as per the attached, I respectfully request that you introduce the attached ordinance at the next City Council meeting.

If you have any questions regarding this ordinance, please contact Anthony Bertuca at (312) 744-5506.

Department of Business Affairs and Consumer Protection



City of Chicago



O2014-4504

Office of the City Clerk

Document Tracking Sheet

Meeting Date: 5/28/2014

Sponsor(s): Waguespack (32)

Type: Ordinance

Title: Grant(s) of privilege in public way for Goose Island Shrimp House, Inc.

Committee(s) Assignment: Committee on Transportation and Public Way

ORDINANCE
GOOSE ISLAND SHRIMP HOUSE INC
Acct. No. 3986 - 1
Permit No. 1113099

Be It Ordained by the City Council of the City of Chicago:

SECTION 1. Permission and authority are hereby given and granted to GOOSE ISLAND SHRIMP HOUSE INC, upon the terms and subject to the conditions of this ordinance to maintain and use one (1) sign(s) projecting over the public right-of-way attached to its premises known as 1013 W. Division St..

Said sign structure(s) measures as follows; along W Division St:
One (1) at five (5) feet in length, eleven point five (11.5) feet in height and ten point two five (10.25) feet above grade level.

The location of said privilege shall be as shown on prints kept on file with the Department of Business Affairs and Consumer Protection and the Office of the City Clerk.

Said privilege shall be constructed in accordance with plans and specifications approved by the Department of Transportation (Division of Project Development) and Zoning Department - Signs.

This grant of privilege in the public way shall be subject to the provisions of Section 10-28-015 and all other required provisions of the Municipal Code of Chicago.

The grantee shall pay to the City of Chicago as compensation for the privilege #1113099 herein granted the sum of three hundred (\$300.00) per annum in advance.

A 25% penalty will be added for payments received after due date.

The permit holder agrees to hold the City of Chicago harmless for any damage, relocation or replacement costs associated with damage, relocation or removal of private property caused by the City performing work in the public way.

Authority herein given and granted for a period of five (5) years from and after 04/22/2014.

Alderman



Scott Waguespack 32nd Ward

[Faint, illegible text]

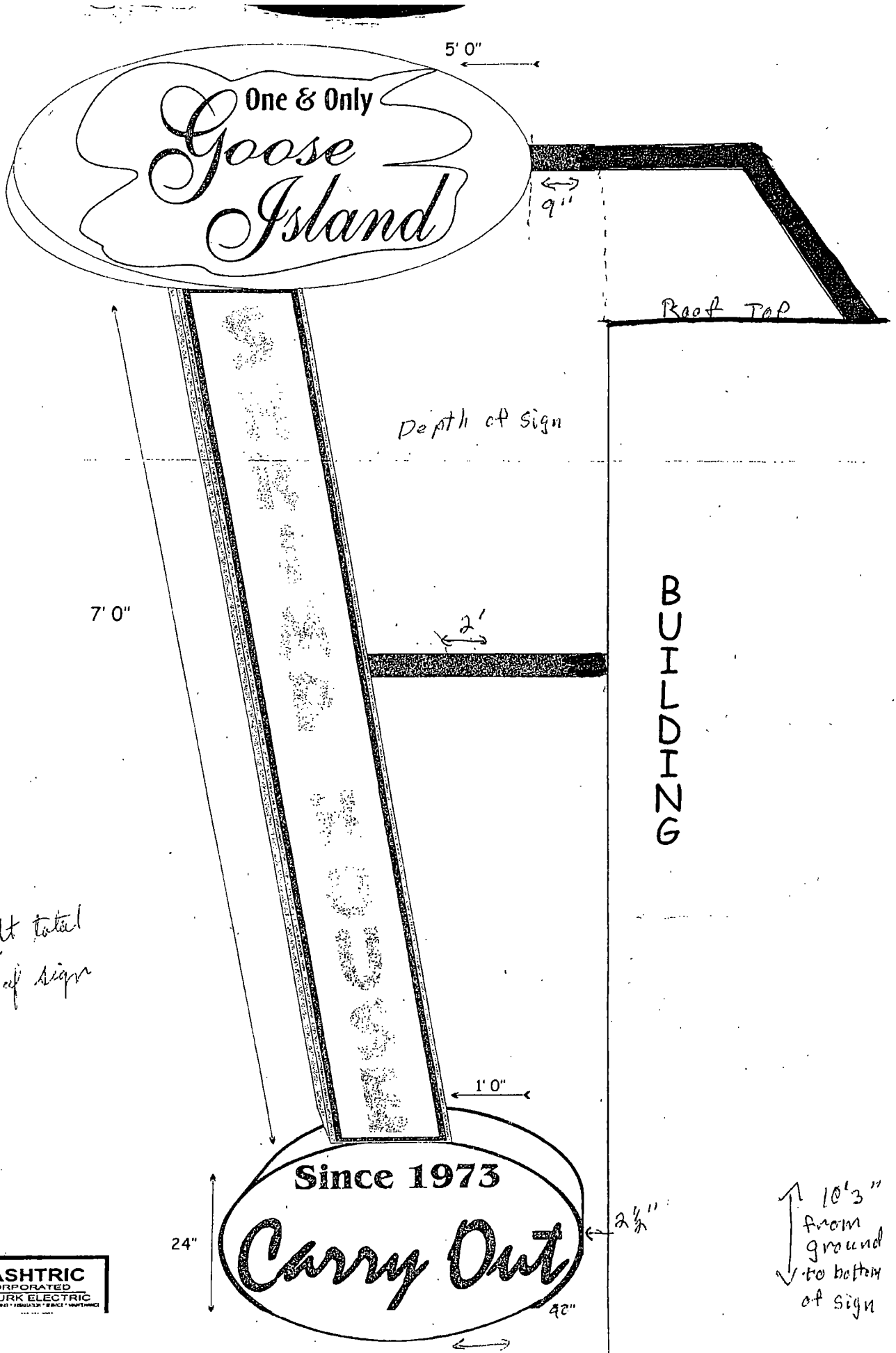

11 1/2 ft total length of sign





05/28/2014

Alderman Scott Waguespack
Ward # **32**
City of Chicago
City Hall, Room **300**
121 North LaSalle Street
Chicago, Illinois 60602

Re: An ordinance to use and maintain a portion of the public right-of-way for **one (1) sign(s)** for **GOOSE ISLAND SHRIMP HOUSE INC**, adjacent to the premises known as **1013 W. Division St.**

Dear Alderman **Scott Waguespack**:

The applicant referenced above has requested the use of the public right-of-way for a **sign(s)**. An ordinance has been prepared by the Department of Business Affairs and Consumer Protection – Small Business Center - Public Way Use Unit for presentation to the City Council. Because this request was made for properties located in your ward, as approved by you as per the attached, I respectfully request that you introduce the attached ordinance at the next City Council meeting.

If you have any questions regarding this ordinance, please contact Anthony Bertuca at (312) 744-5506.

Department of Business Affairs and Consumer Protection



City of Chicago



O2014-4506

Office of the City Clerk

Document Tracking Sheet

| | |
|---------------------------------|---|
| Meeting Date: | 5/28/2014 |
| Sponsor(s): | Waguespack (32) |
| Type: | Ordinance |
| Title: | Grant(s) of privilege in public way for Horween Leather Co. |
| Committee(s) Assignment: | Committee on Transportation and Public Way |

ORDINANCE
HORWEEN LEATHER CO
Acct. No. 2850 - 1
Permit No. 1113110

Be It Ordained by the City Council of the City of Chicago:

SECTION 1. Permission and authority are hereby given and granted to HORWEEN LEATHER CO, upon the terms and subject to the conditions of this ordinance to maintain and use, as now constructed, to occupy and use one thousand four hundred eighty-one point six seven (1,481.67) square feet of space for the purpose of housing three (3) sheds and a hopper extending to the roof at the rear of the building located at 2015-2021 North Elston Avenue on the westerly side of the sixty-six (66) foot right-of-way of North Mendell Street..

The location of said privilege shall be as shown on prints kept on file with the Department of Business Affairs and Consumer Protection and the Office of the City Clerk.

Said privilege shall be constructed in accordance with plans and specifications approved by the Department of Planning and Development, Department of Transportation (Division of Project Development), and Department of Transportation (Office of Underground Coordination).

This grant of privilege in the public way shall be subject to the provisions of Section 10-28-015 and all other required provisions of the Municipal Code of Chicago.

The grantee shall pay to the City of Chicago as compensation for the privilege #1113110 herein granted the sum of one thousand four hundred fifty-one (\$1,451.00) per annum in advance.

A 25% penalty will be added for payments received after due date.

The permit holder agrees to hold the City of Chicago harmless for any damage, relocation or replacement costs associated with damage, relocation or removal of private property caused by the City performing work in the public way.

Authority herein given and granted for a period of five (5) years from and after 04/01/2014.

Alderman 
Scott Waguespack 32nd Ward

11/11/11

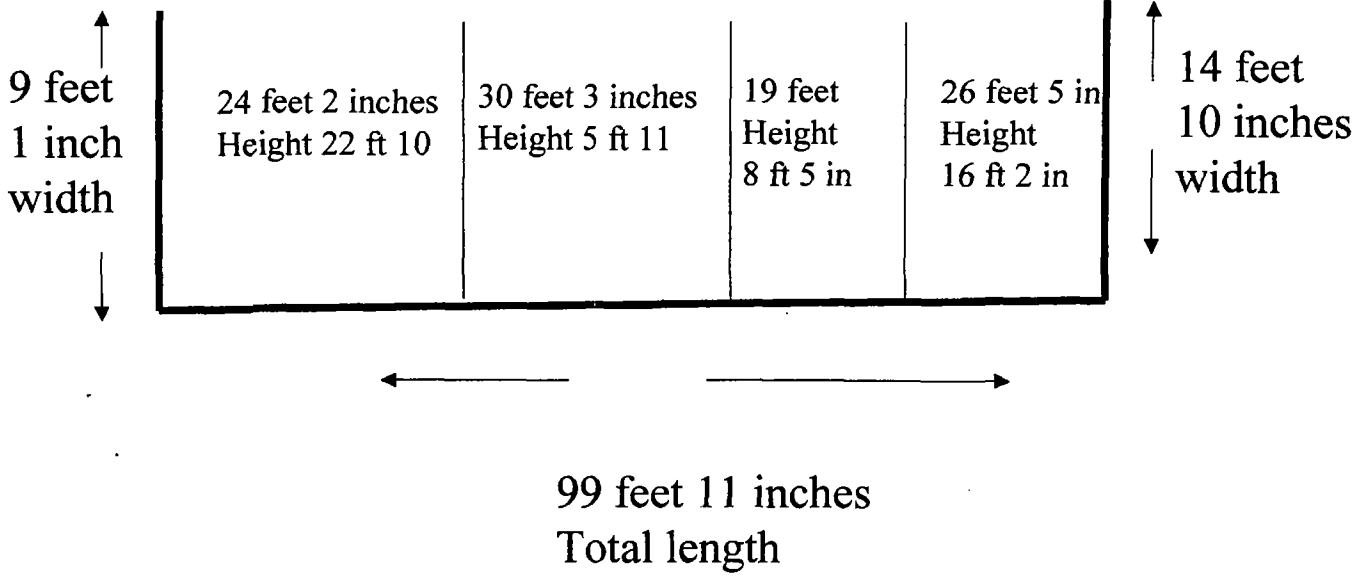



05/28/2014

Alderman Scott Waguespack
Ward # 32
City of Chicago
City Hall, Room 300
121 North LaSalle Street
Chicago, Illinois 60602

Re: An ordinance to use and maintain a portion of the public right-of-way for **one (1) occupation of space(s)** for **HORWEEN LEATHER CO**, adjacent to the premises known as **2015-2021 N. Elston Ave.**.

Dear Alderman **Scott Waguespack**:

The applicant referenced above has requested the use of the public right-of-way for a **occupation of space(s)**. An ordinance has been prepared by the Department of Business Affairs and Consumer Protection – Small Business Center - Public Way Use Unit for presentation to the City Council. Because this request was made for properties located in your ward, as approved by you as per the attached, I respectfully request that you introduce the attached ordinance at the next City Council meeting.

If you have any questions regarding this ordinance, please contact Anthony Bertuca at (312) 744-5506.

Department of Business Affairs and Consumer Protection



City of Chicago



O2014-4507

Office of the City Clerk

Document Tracking Sheet

| | |
|---------------------------------|---|
| Meeting Date: | 5/28/2014 |
| Sponsor(s): | Waguespack (32) |
| Type: | Ordinance |
| Title: | Grant(s) of privilege in public way for Neil Kauffman |
| Committee(s) Assignment: | Committee on Transportation and Public Way |

ORDINANCE
NEIL KAUFFMAN
Acct. No. 76703 - 1
Permit No. 1113039

Be It Ordained by the City Council of the City of Chicago:

SECTION 1. Permission and authority are hereby given and granted to NEIL KAUFFMAN, upon the terms and subject to the conditions of this ordinance to maintain and use one (1) sign(s) projecting over the public right-of-way attached to its premises known as 1944 W. Chicago Ave..

Said sign structure(s) measures as follows; along W. CHICAGO:

One (1) at five (5) feet in length, three (3) feet in height and eleven point three three (11.33) feet above grade level.

The location of said privilege shall be as shown on prints kept on file with the Department of Business Affairs and Consumer Protection and the Office of the City Clerk.

Said privilege shall be constructed in accordance with plans and specifications approved by the Department of Transportation (Division of Project Development) and Zoning Department - Signs.

This grant of privilege in the public way shall be subject to the provisions of Section 10-28-015 and all other required provisions of the Municipal Code of Chicago.

The grantee shall pay to the City of Chicago as compensation for the privilege #1113039 herein granted the sum of one hundred (\$100.00) per annum in advance.

A 25% penalty will be added for payments received after due date.

The permit holder agrees to hold the City of Chicago harmless for any damage, relocation or replacement costs associated with damage, relocation or removal of private property caused by the City performing work in the public way.

Authority herein given and granted for a period of five (5) years from and after 05/13/2014.

Alderman 
Scott Waguespack 32nd Ward

LAW OFFICES

284 - 6295



05/28/2014

Alderman **Scott Waguespack**
Ward # **32**
City of Chicago
City Hall, Room **300**
121 North LaSalle Street
Chicago, Illinois 60602

Re: An ordinance to use and maintain a portion of the public right-of-way for **one (1) sign(s)** for **NEIL KAUFFMAN**, adjacent to the premises known as **1944 W. Chicago Ave.**.

Dear Alderman **Scott Waguespack**:

The applicant referenced above has requested the use of the public right-of-way for a **sign(s)**. An ordinance has been prepared by the Department of Business Affairs and Consumer Protection – Small Business Center - Public Way Use Unit for presentation to the City Council. Because this request was made for properties located in your ward, as approved by you as per the attached, I respectfully request that you introduce the attached ordinance at the next City Council meeting.

If you have any questions regarding this ordinance, please contact Anthony Bertuca at (312) 744-5506.

Department of Business Affairs and Consumer Protection



City of Chicago

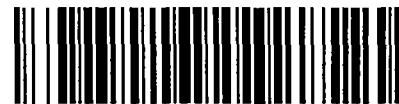

O2014-4510

Office of the City Clerk

Document Tracking Sheet

| | |
|---------------------------------|--|
| Meeting Date: | 5/28/2014 |
| Sponsor(s): | Waguespack (32) |
| Type: | Ordinance |
| Title: | Grant(s) of privilege in public way for North Community Bank |
| Committee(s) Assignment: | Committee on Transportation and Public Way |

ORDINANCE
NORTH COMMUNITY BANK
Acct. No. 87701 - 5
Permit No. 1113100

Be It Ordained by the City Council of the City of Chicago:

SECTION 1. Permission and authority are hereby given and granted to NORTH COMMUNITY BANK, upon the terms and subject to the conditions of this ordinance to maintain and use one (1) sign(s) projecting over the public right-of-way attached to its premises known as 1401 W. Belmont Ave..

Said sign structure(s) measures as follows; along W BELMONT AVE:
One (1) at eight point five (8.5) feet in length, seven (7) feet in height and ten (10) feet above grade level.

The location of said privilege shall be as shown on prints kept on file with the Department of Business Affairs and Consumer Protection and the Office of the City Clerk.

Said privilege shall be constructed in accordance with plans and specifications approved by the Department of Transportation (Division of Project Development) and Zoning Department - Signs.

This grant of privilege in the public way shall be subject to the provisions of Section 10-28-015 and all other required provisions of the Municipal Code of Chicago.

The grantee shall pay to the City of Chicago as compensation for the privilege #1113100 herein granted the sum of three hundred (\$300.00) per annum in advance.

A 25% penalty will be added for payments received after due date.

The permit holder agrees to hold the City of Chicago harmless for any damage, relocation or replacement costs associated with damage, relocation or removal of private property caused by the City performing work in the public way.

Authority herein given and granted for a period of five (5) years from and after 04/22/2014.

Alderman



Scott Waguespack 32nd Ward

12/15/2020

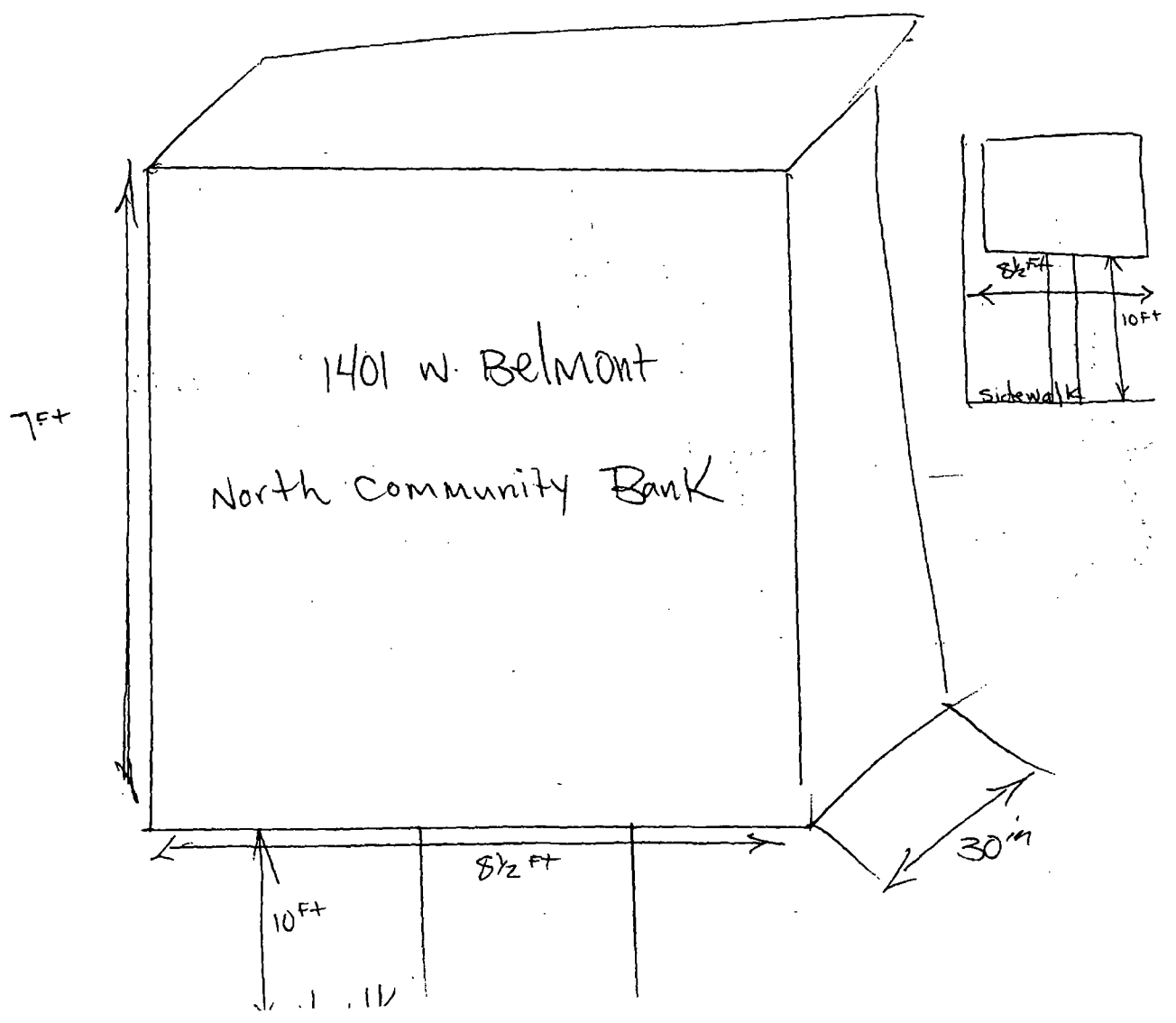



05/28/2014

Alderman **Scott Waguespack**
Ward # **32**
City of Chicago
City Hall, Room **300**
121 North LaSalle Street
Chicago, Illinois 60602

Re: An ordinance to use and maintain a portion of the public right-of-way for **one (1) sign(s)** for **NORTH COMMUNITY BANK**, adjacent to the premises known as **1401 W. Belmont Ave.**.

Dear Alderman **Scott Waguespack**:

The applicant referenced above has requested the use of the public right-of-way for a **sign(s)**. An ordinance has been prepared by the Department of Business Affairs and Consumer Protection – Small Business Center - Public Way Use Unit for presentation to the City Council. Because this request was made for properties located in your ward, as approved by you as per the attached, I respectfully request that you introduce the attached ordinance at the next City Council meeting.

If you have any questions regarding this ordinance, please contact Anthony Bertuca at (312) 744-5506.

Department of Business Affairs and Consumer Protection



City of Chicago



O2014-4518

Office of the City Clerk

Document Tracking Sheet

| | |
|---------------------------------|--|
| Meeting Date: | 5/28/2014 |
| Sponsor(s): | Waguespack (32) |
| Type: | Ordinance |
| Title: | Grant(s) of privilege in public way for Roscoe Village Chamber of Commerce - 1819 W Belmont Ave |
| Committee(s) Assignment: | Committee on Transportation and Public Way |

ORDINANCE

Roscoe Village Chamber of Commerce

Acct. No. 389975 - 12

Permit No. 1112804

Be It Ordained by the City Council of the City of Chicago:

SECTION 1. Permission and authority are hereby given and granted to Roscoe Village Chamber of Commerce, upon the terms and subject to the conditions of this ordinance to construct, install, maintain and use one (1) Planter(s) on the public right-of-way for beautification purposes adjacent to its premises known as 1819 W. Belmont Ave..

Said Planter(s) at Belmont measure(s):

One (1) at six point zero eight (6.08) feet in length, and one (1) foot in width for a total of six point zero eight (6.08) square feet.

Grantee must allow the required clear and unobstructed space for pedestrian passage at all times per rules and regulations approved by the Department of Transportation.

The location of said privilege shall be as shown on prints kept on file with the Department of Business Affairs and Consumer Protection and the Office of the City Clerk.

Said privilege shall be constructed in accordance with plans and specifications approved by the Department of Planning and Development and Department of Transportation (Division of Project Development).

This grant of privilege in the public way shall be subject to the provisions of Section 10-28-015 and all other required provisions of the Municipal Code of Chicago.

The grantee shall pay to the City of Chicago as compensation for the privilege #1112804 herein granted the sum of zero (\$.00) per annum in advance.

A 25% penalty will be added for payments received after due date.

The permit holder agrees to hold the City of Chicago harmless for any damage, relocation or replacement costs associated with damage, relocation or removal of private property caused by the City performing work in the public way.

Authority herein given and granted for a period of five (5) years from and after Date of Passage.

Alderman  _____
Scott Waguespack 32nd Ward

ROSCOE VILLAGE CHAMBER OF COMMERCE

ADDRESS: 1819 W BEUMONT

LANDSCAPING PROGRAM 2014

(NOT TO SCALE)

NO PARKING (CORNER CLEARANCE)

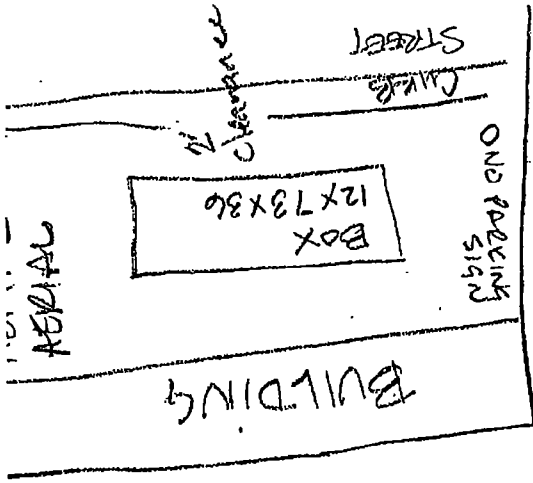
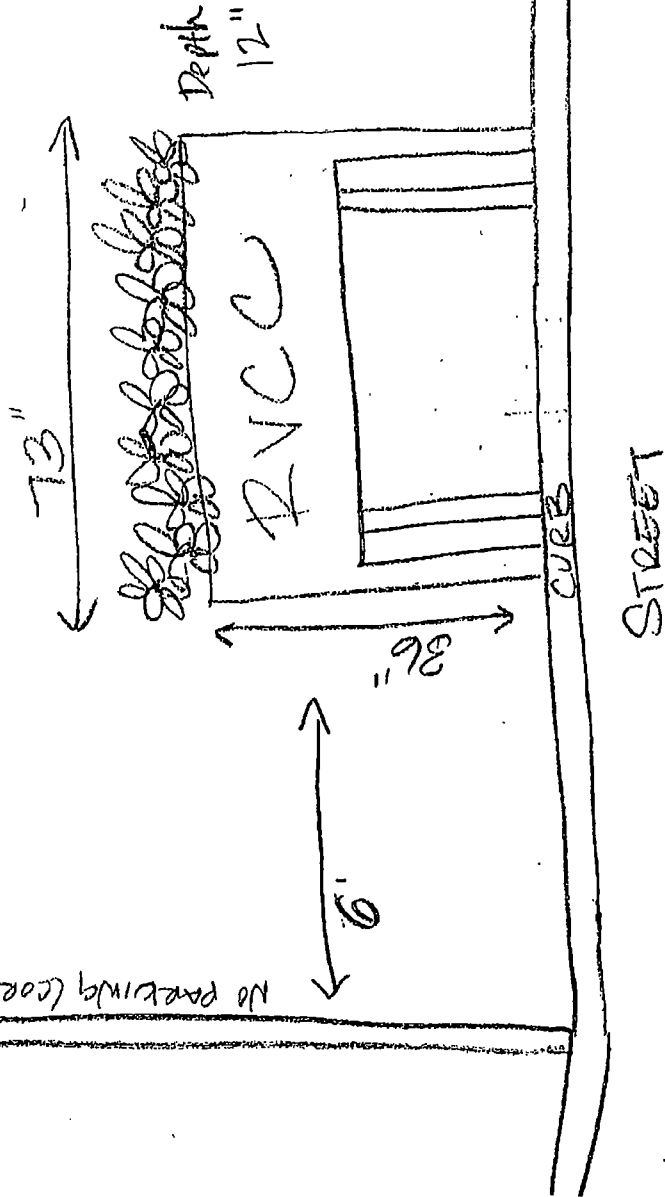



05/28/2014

Alderman **Scott Waguespack**
Ward # **32**
City of Chicago
City Hall, Room **300**
121 North LaSalle Street
Chicago, Illinois 60602

Rc: An ordinance to use and maintain a portion of the public right-of-way for **one (1) planter(s)** for **Roscoe Village Chamber of Commerce**, adjacent to the premises known as **1819 W. Belmont Ave.**

Dear Alderman **Scott Waguespack**:

The applicant referenced above has requested the use of the public right-of-way for a **planter(s)**. An ordinance has been prepared by the Department of Business Affairs and Consumer Protection – Small Business Center - Public Way Use Unit for presentation to the City Council. Because this request was made for properties located in your ward, as approved by you as per the attached, I respectfully request that you introduce the attached ordinance at the next City Council meeting.

If you have any questions regarding this ordinance, please contact Anthony Bertuca at (312) 744-5506.

Department of Business Affairs and Consumer Protection



City of Chicago



O2014-4523

Office of the City Clerk

Document Tracking Sheet

| | |
|---------------------------------|--|
| Meeting Date: | 5/28/2014 |
| Sponsor(s): | Waguespack (32) |
| Type: | Ordinance |
| Title: | Grant(s) of privilege in public way for Roscoe Village Chamber of Commerce - 1900 W Belmont Ave |
| Committee(s) Assignment: | Committee on Transportation and Public Way |

ORDINANCE

Roscoe Villlage Chamber of Commerce

Acct. No. 389975 - 10

Permit No. 1112802

Be It Ordained by the City Council of the City of Chicago:

SECTION 1. Permission and authority are hereby given and granted to Roscoe Villlage Chamber of Commerce, upon the terms and subject to the conditions of this ordinance to construct, install, maintain and use one (1) Planter(s) on the public right-of-way for beautification purposes adjacent to its premises known as 1900 W. Belmont Ave..

Said Planter(s) at Belmont measure(s):

One (1) at six point zero eight (6.08) feet in length, and one (1) foot in width for a total of six point zero eight (6.08) square feet.

Grantee must allow the required clear and unobstructed space for pedestrian passage at all times per rules and regulations approved by the Department of Transportation.

The location of said privilege shall be as shown on prints kept on file with the Department of Business Affairs and Consumer Protection and the Office of the City Clerk.

Said privilege shall be constructed in accordance with plans and specifications approved by the Department of Planning and Development and Department of Transportation (Division of Project Development).

This grant of privilege in the public way shall be subject to the provisions of Section 10-28-015 and all other required provisions of the Municipal Code of Chicago.

The grantee shall pay to the City of Chicago as compensation for the privilege #1112802 herein granted the sum of zero (\$.00) per annum in advance.

A 25% penalty will be added for payments received after due date.

The permit holder agrees to hold the City of Chicago harmless for any damage, relocation or replacement costs associated with damage, relocation or removal of private property caused by the City performing work in the public way.

Authority herein given and granted for a period of five (5) years from and after Date of Passage.

Alderman  _____
Scott Waguespack 32nd Ward

ROSCOE VILLAGE CHAMBER OF COMMERCE

ADDRESS: 1900 W BELMONT

LANDSCAPING PROGRAM 2014

(NOT TO SCALE)

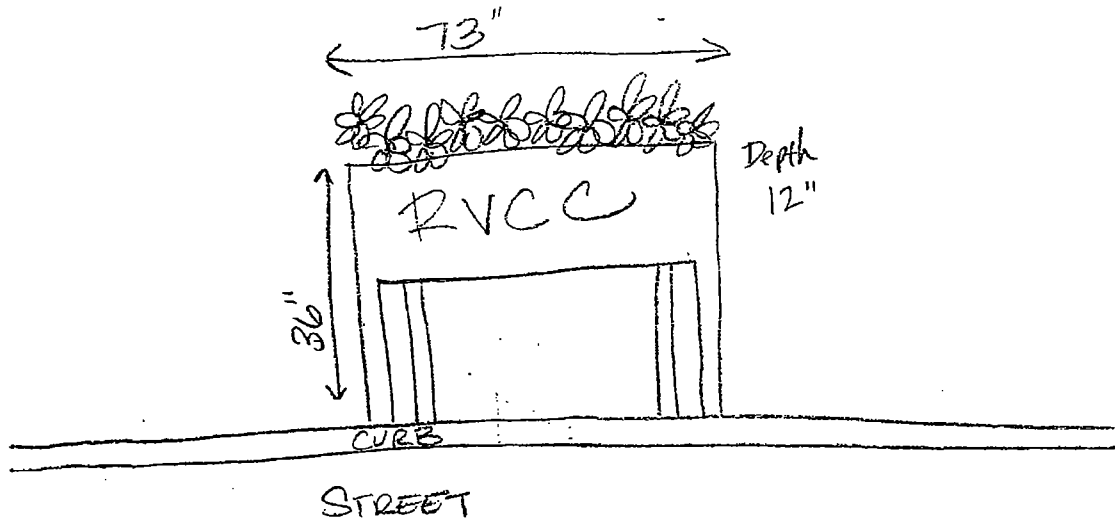
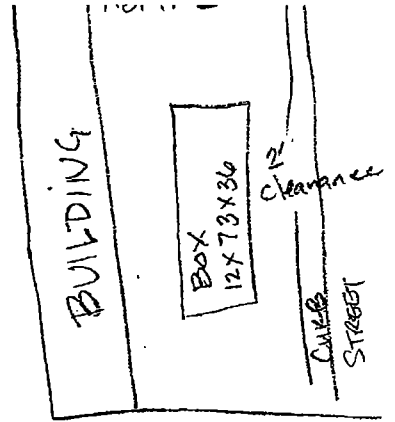



05/28/2014

Alderman **Scott Waguespack**
Ward # **32**
City of Chicago
City Hall, Room **300**
121 North LaSalle Street
Chicago, Illinois 60602

Re: An ordinance to use and maintain a portion of the public right-of-way for **one (1) planter(s)** for **Roscoe Village Chamber of Commerce**, adjacent to the premises known as **1900 W. Belmont Ave.**.

Dear Alderman **Scott Waguespack**:

The applicant referenced above has requested the use of the public right-of-way for a **planter(s)**. An ordinance has been prepared by the Department of Business Affairs and Consumer Protection – Small Business Center - Public Way Use Unit for presentation to the City Council. Because this request was made for properties located in your ward, as approved by you as per the attached, I respectfully request that you introduce the attached ordinance at the next City Council meeting.

If you have any questions regarding this ordinance, please contact Anthony Bertuca at (312) 744-5506.

Department of Business Affairs and Consumer Protection



City of Chicago



O2014-4525

Office of the City Clerk

Document Tracking Sheet

Meeting Date: 5/28/2014

Sponsor(s): Waguespack (32)

Type: Ordinance

Title: Grant(s) of privilege in public way for Roscoe Village
Chamber of Commerce - 1948 W Belmont Ave

Committee(s) Assignment: Committee on Transportation and Public Way

ORDINANCE
Roscoe Village Chamber of Commerce
Acct. No. 389975 - 13
Permit No. 1112807

Be It Ordained by the City Council of the City of Chicago:

SECTION 1. Permission and authority are hereby given and granted to Roscoe Village Chamber of Commerce, upon the terms and subject to the conditions of this ordinance to construct, install, maintain and use one (1) Planter(s) on the public right-of-way for beautification purposes adjacent to its premises known as 1948 W. Belmont Ave..

Said Planter(s) at Belmont measure(s):

One (1) at six point zero eight (6.08) feet in length, and one (1) foot in width for a total of six point zero eight (6.08) square feet.

Grantee must allow the required clear and unobstructed space for pedestrian passage at all times per rules and regulations approved by the Department of Transportation.

The location of said privilege shall be as shown on prints kept on file with the Department of Business Affairs and Consumer Protection and the Office of the City Clerk.

Said privilege shall be constructed in accordance with plans and specifications approved by the Department of Planning and Development and Department of Transportation (Division of Project Development).

This grant of privilege in the public way shall be subject to the provisions of Section 10-28-015 and all other required provisions of the Municipal Code of Chicago.

The grantee shall pay to the City of Chicago as compensation for the privilege #1112807 herein granted the sum of zero (\$.00) per annum in advance.

A 25% penalty will be added for payments received after due date.

The permit holder agrees to hold the City of Chicago harmless for any damage, relocation or replacement costs associated with damage, relocation or removal of private property caused by the City performing work in the public way.

Authority herein given and granted for a period of five (5) years from and after Date of Passage.

Alderman  _____
Scott Waguespack 32nd Ward

ROSCOE VILLAGE CHAMBER OF COMMERCE

ADDRESS: 1948 W BELMONT

LANDSCAPING PROGRAM 2014

(NOT TO SCALE)

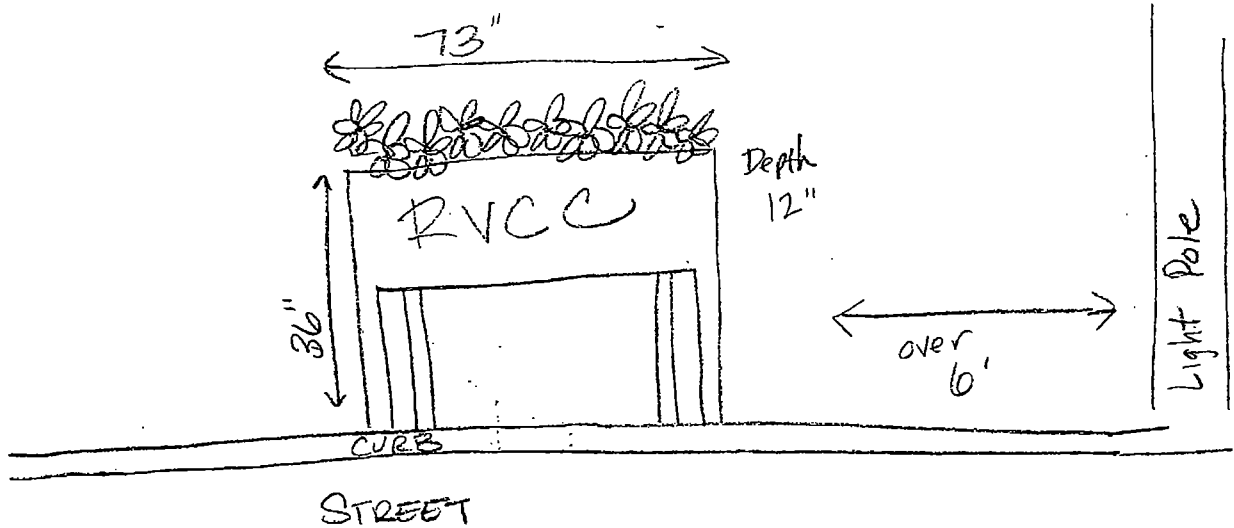
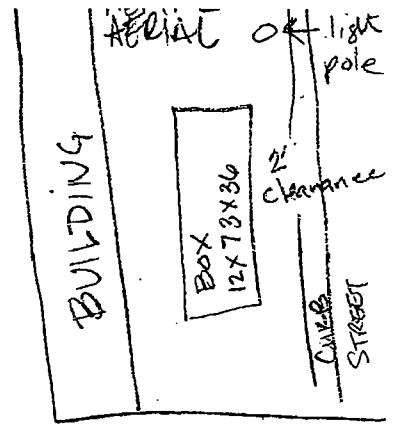



05/28/2014

Alderman Scott Waguespack
Ward # **32**
City of Chicago
City Hall, Room **300**
121 North LaSalle Street
Chicago, Illinois 60602

Re: An ordinance to use and maintain a portion of the public right-of-way for **one (1) planter(s)** for **Roscoe Village Chamber of Commerce**, adjacent to the premises known as **1948 W. Belmont Ave.**.

Dear Alderman **Scott Waguespack**:

The applicant referenced above has requested the use of the public right-of-way for a **planter(s)**. An ordinance has been prepared by the Department of Business Affairs and Consumer Protection – Small Business Center - Public Way Use Unit for presentation to the City Council. Because this request was made for properties located in your ward, as approved by you as per the attached, I respectfully request that you introduce the attached ordinance at the next City Council meeting.

If you have any questions regarding this ordinance, please contact Anthony Bertuca at (312) 744-5506.

Department of Business Affairs and Consumer Protection



City of Chicago



O2014-4530

Office of the City Clerk

Document Tracking Sheet

Meeting Date: 5/28/2014

Sponsor(s): Waguespack (32)

Type: Ordinance

Title: Grant(s) of privilege in public way for Roscoe Village Chamber of Commerce - 2058 W Belmont Ave

Committee(s) Assignment: Committee on Transportation and Public Way

ORDINANCE

Roscoe Village Chamber of Commerce

Acct. No. 389975 - 8

Permit No. 1112799

Be It Ordained by the City Council of the City of Chicago:

SECTION 1. Permission and authority are hereby given and granted to Roscoe Village Chamber of Commerce, upon the terms and subject to the conditions of this ordinance to construct, install, maintain and use one (1) Planter(s) on the public right-of-way for beautification purposes adjacent to its premises known as 2058 W. Belmont Ave..

Said Planter(s) at Belmont measure(s):

One (1) at six point zero eight (6.08) feet in length, and one (1) foot in width for a total of six point zero eight (6.08) square feet.

Grantee must allow the required clear and unobstructed space for pedestrian passage at all times per rules and regulations approved by the Department of Transportation.

The location of said privilege shall be as shown on prints kept on file with the Department of Business Affairs and Consumer Protection and the Office of the City Clerk.

Said privilege shall be constructed in accordance with plans and specifications approved by the Department of Planning and Development and Department of Transportation (Division of Project Development).

This grant of privilege in the public way shall be subject to the provisions of Section 10-28-015 and all other required provisions of the Municipal Code of Chicago.

The grantee shall pay to the City of Chicago as compensation for the privilege #1112799 herein granted the sum of zero (\$0.00) per annum in advance.

A 25% penalty will be added for payments received after due date.

The permit holder agrees to hold the City of Chicago harmless for any damage, relocation or replacement costs associated with damage, relocation or removal of private property caused by the City performing work in the public way.

Authority herein given and granted for a period of five (5) years from and after Date of Passage.

Alderman 
Scott Waguespack 32nd Ward

ROSCOE VILLAGE CHAMBER OF COMMERCE
ADDRESS: 2076 W BELMONT
LANDSCAPING PROGRAM 2014
(NOT TO SCALE)

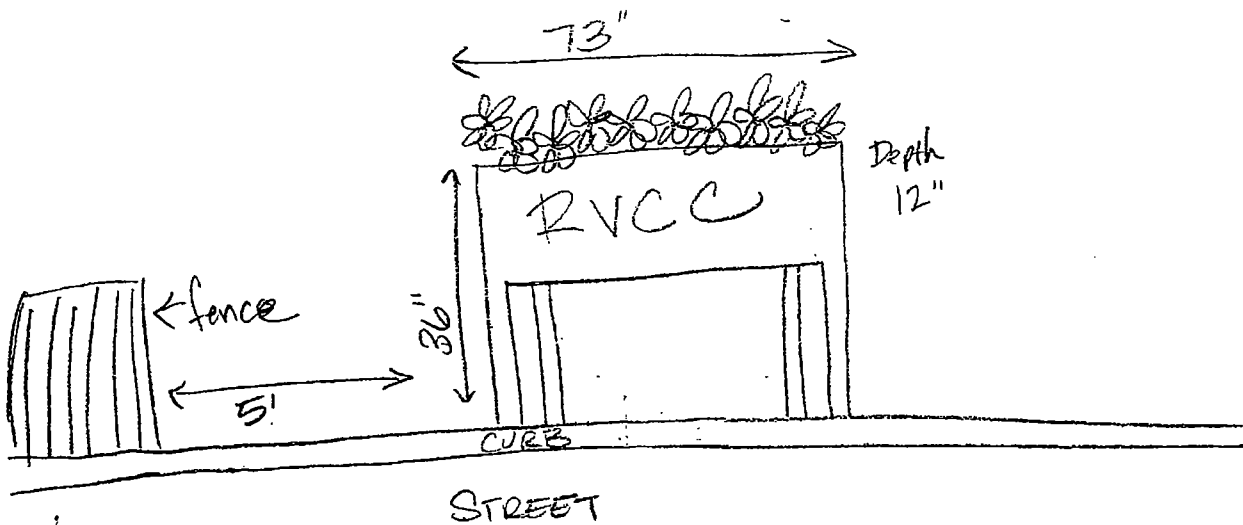



05/28/2014

Alderman **Scott Waguespack**
Ward # **32**
City of Chicago
City Hall, Room **300**
121 North LaSalle Street
Chicago, Illinois 60602

Re: An ordinance to use and maintain a portion of the public right-of-way for **one (1) planter(s)** for **Roscoe Village Chamber of Commerce**, adjacent to the premises known as **2058 W. Belmont Ave.**.

Dear Alderman **Scott Waguespack**:

The applicant referenced above has requested the use of the public right-of-way for a **planter(s)**. An ordinance has been prepared by the Department of Business Affairs and Consumer Protection – Small Business Center - Public Way Use Unit for presentation to the City Council. Because this request was made for properties located in your ward, as approved by you as per the attached, I respectfully request that you introduce the attached ordinance at the next City Council meeting.

If you have any questions regarding this ordinance, please contact Anthony Bertuca at (312) 744-5506.

Department of Business Affairs and Consumer Protection



City of Chicago



O2014-4532

Office of the City Clerk

Document Tracking Sheet

Meeting Date: 5/28/2014

Sponsor(s): Waguespack (32)

Type: Ordinance

Title: Grant(s) of privilege in public way for Roscoe Village
Chamber of Commerce - 2059 W Belmont Ave

Committee(s) Assignment: Committee on Transportation and Public Way

ORDINANCE
Roscoe Village Chamber of Commerce
Acct. No. 389975 - 7
Permit No. 1112797

Be It Ordained by the City Council of the City of Chicago:

SECTION 1. Permission and authority are hereby given and granted to Roscoe Village Chamber of Commerce, upon the terms and subject to the conditions of this ordinance to construct, install, maintain and use one (1) Planter(s) on the public right-of-way for beautification purposes adjacent to its premises known as 2059 W. Belmont Ave..

Said Planter(s) at Belmont measure(s):
One (1) at six point zero eight (6.08) feet in length, and one (1) foot in width for a total of six point zero eight (6.08) square feet.

Grantee must allow the required clear and unobstructed space for pedestrian passage at all times per rules and regulations approved by the Department of Transportation.

The location of said privilege shall be as shown on prints kept on file with the Department of Business Affairs and Consumer Protection and the Office of the City Clerk.

Said privilege shall be constructed in accordance with plans and specifications approved by the Department of Planning and Development and Department of Transportation (Division of Project Development).

This grant of privilege in the public way shall be subject to the provisions of Section 10-28-015 and all other required provisions of the Municipal Code of Chicago.

The grantee shall pay to the City of Chicago as compensation for the privilege #1112797 herein granted the sum of zero (\$.00) per annum in advance.

A 25% penalty will be added for payments received after due date.

The permit holder agrees to hold the City of Chicago harmless for any damage, relocation or replacement costs associated with damage, relocation or removal of private property caused by the City performing work in the public way.

Authority herein given and granted for a period of five (5) years from and after Date of Passage.

Alderman 
Scott Waguespack 32nd Ward

ROSCOE VILLAGE CHAMBER OF COMMERCE
ADDRESS: 2059 W BELMONT
LANDSCAPING PROGRAM 2014
(NOT TO SCALE)

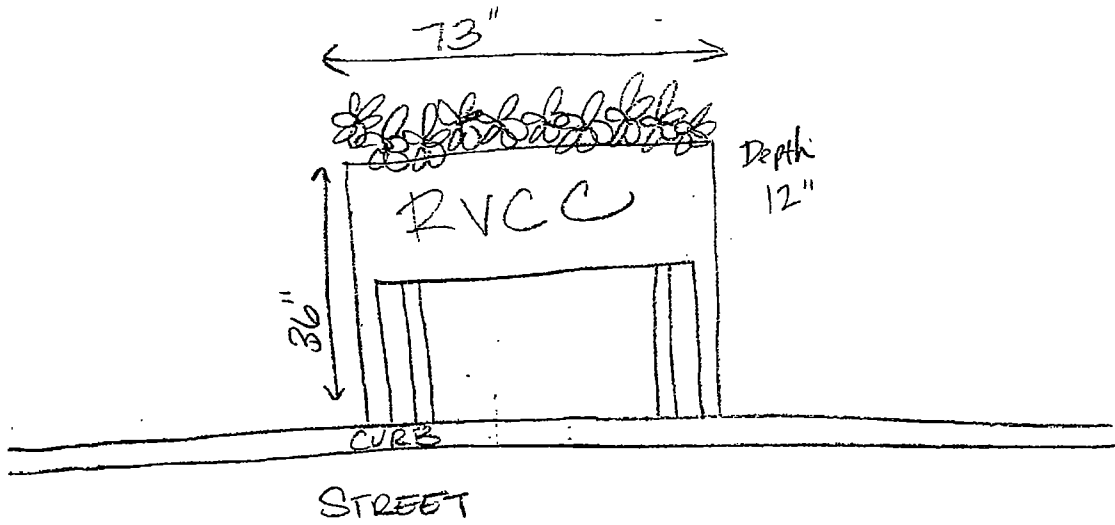
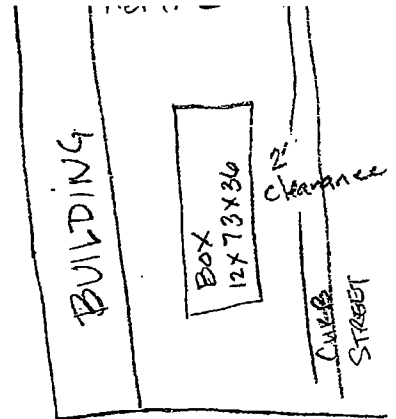



Department of Business Affairs and Consumer Protection
Small Business Center - Public Way Use Unit
City Hall - 121 N. LaSalle Street, Room 800 • Chicago, IL 60602
(312)-74-GOBIZ (312-744-6249) • (312) 744-1944 (TTY)
<http://www.cityofchicago.org/bacp>

05/28/2014

Alderman Scott Waguespack
Ward # 32
City of Chicago
City Hall, Room 300
121 North LaSalle Street
Chicago, Illinois 60602

Re: An ordinance to use and maintain a portion of the public right-of-way for **one (1) planter(s)** for **Roscoe Village Chamber of Commerce**, adjacent to the premises known as **2059 W. Belmont Ave.**.

Dear Alderman **Scott Waguespack**:

The applicant referenced above has requested the use of the public right-of-way for a **planter(s)**. An ordinance has been prepared by the Department of Business Affairs and Consumer Protection – Small Business Center - Public Way Use Unit for presentation to the City Council. Because this request was made for properties located in your ward, as approved by you as per the attached, I respectfully request that you introduce the attached ordinance at the next City Council meeting.

If you have any questions regarding this ordinance, please contact Anthony Bertuca at (312) 744-5506.

Department of Business Affairs and Consumer Protection



City of Chicago



O2014-4537

Office of the City Clerk

Document Tracking Sheet

Meeting Date: 5/28/2014

Sponsor(s): Waguespack (32)

Type: Ordinance

Title: Grant(s) of privilege in public way for Roscoe Village
Chamber of Commerce - 2159 W Belmont Ave

Committee(s) Assignment: Committee on Transportation and Public Way

ORDINANCE

Roscoe Village Chamber of Commerce

Acct. No. 389975 - 2

Permit No. 1112758

Be It Ordained by the City Council of the City of Chicago:

SECTION 1. Permission and authority are hereby given and granted to Roscoe Village Chamber of Commerce, upon the terms and subject to the conditions of this ordinance to construct, install, maintain and use one (1) Planter(s) on the public right-of-way for beautification purposes adjacent to its premises known as 2159 W. Belmont Ave..

Said Planter(s) at W. Belmont measure(s):

One (1) at six point zero eight (6.08) feet in length, and one (1) foot in width for a total of six point zero eight (6.08) square feet.

Grantee must allow the required clear and unobstructed space for pedestrian passage at all times per rules and regulations approved by the Department of Transportation.

The location of said privilege shall be as shown on prints kept on file with the Department of Business Affairs and Consumer Protection and the Office of the City Clerk.

Said privilege shall be constructed in accordance with plans and specifications approved by the Department of Planning and Development and Department of Transportation (Division of Project Development).

This grant of privilege in the public way shall be subject to the provisions of Section 10-28-015 and all other required provisions of the Municipal Code of Chicago.

The grantee shall pay to the City of Chicago as compensation for the privilege #1112758 herein granted the sum of zero (\$.00) per annum in advance.

A 25% penalty will be added for payments received after due date.

The permit holder agrees to hold the City of Chicago harmless for any damage, relocation or replacement costs associated with damage, relocation or removal of private property caused by the City performing work in the public way.

Authority herein given and granted for a period of five (5) years from and after Date of Passage.

Alderman Scott Waguespack
Scott Waguespack 32nd Ward

Handwritten text, possibly a signature or name, located in the lower-left quadrant of the page.

ROSCOE VILLAGE CHAMBER OF COMMERCE
ADDRESS: 2159 W BELMONT
LANDSCAPING PROGRAM 2014
(NOT TO SCALE)

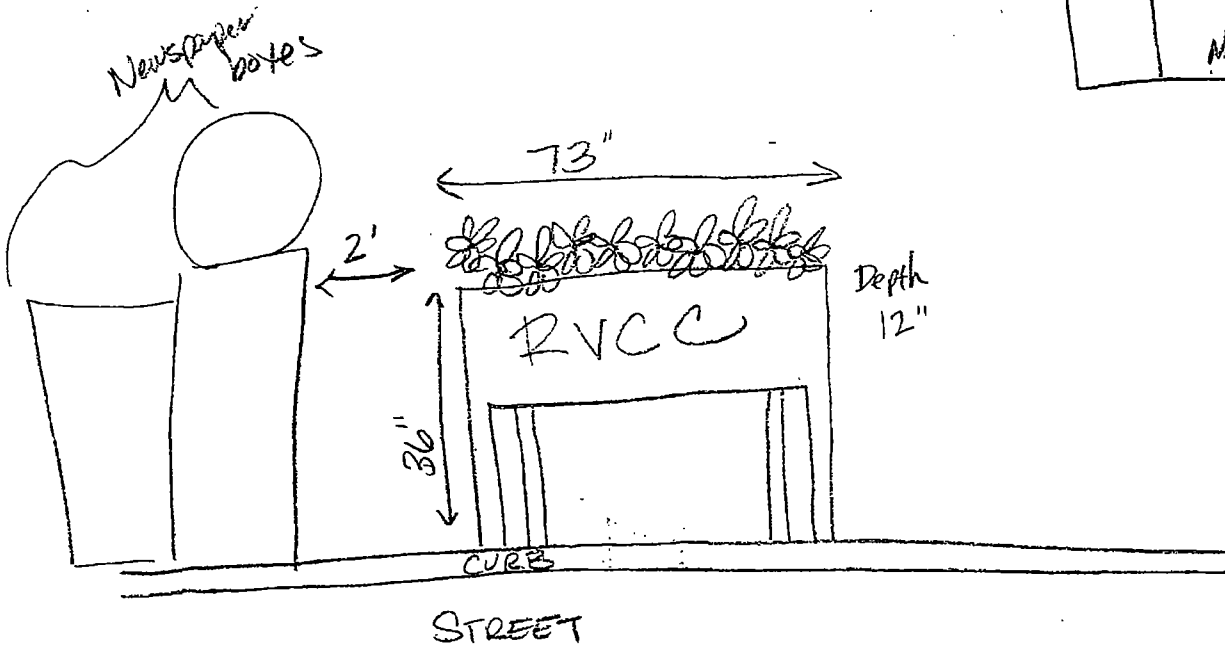
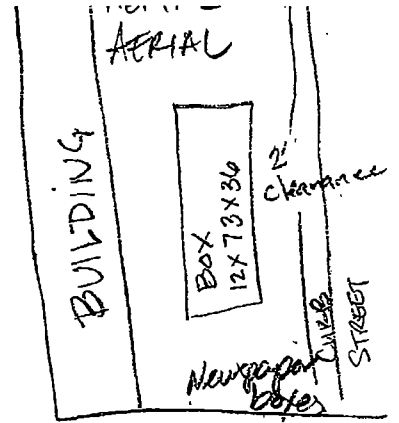



05/28/2014

Alderman **Scott Waguespack**
Ward # **32**
City of Chicago
City Hall, Room **300**
121 North LaSalle Street
Chicago, Illinois 60602

Re: An ordinance to use and maintain a portion of the public right-of-way for **one (1) planter(s)** for **Roscoe Village Chamber of Commerce**, adjacent to the premises known as **2159 W. Belmont Ave.**.

Dear Alderman **Scott Waguespack**:

The applicant referenced above has requested the use of the public right-of-way for a **planter(s)**. An ordinance has been prepared by the Department of Business Affairs and Consumer Protection – Small Business Center - Public Way Use Unit for presentation to the City Council. Because this request was made for properties located in your ward, as approved by you as per the attached, I respectfully request that you introduce the attached ordinance at the next City Council meeting.

If you have any questions regarding this ordinance, please contact Anthony Bertuca at (312) 744-5506.

Department of Business Affairs and Consumer Protection



City of Chicago



O2014-4541

Office of the City Clerk

Document Tracking Sheet

| | |
|---------------------------------|--|
| Meeting Date: | 5/28/2014 |
| Sponsor(s): | Waguespack (32) |
| Type: | Ordinance |
| Title: | Grant(s) of privilege in public way for Roscoe Village Chamber of Commerce - 2200 W Belmont Ave |
| Committee(s) Assignment: | Committee on Transportation and Public Way |

ORDINANCE
Roscoe Village Chamber of Commerce
Acct. No. 389975 - 5
Permit No. 1112763

Be It Ordained by the City Council of the City of Chicago:

SECTION 1. Permission and authority are hereby given and granted to Roscoe Village Chamber of Commerce, upon the terms and subject to the conditions of this ordinance to construct, install, maintain and use one (1) Planter(s) on the public right-of-way for beautification purposes adjacent to its premises known as 2200 W. Belmont Ave..

Said Planter(s) at W. Belmont measure(s):

One (1) at six point zero eight (6.08) feet in length, and one (1) foot in width for a total of six point zero eight (6.08) square feet.

Grantee must allow the required clear and unobstructed space for pedestrian passage at all times per rules and regulations approved by the Department of Transportation.

The location of said privilege shall be as shown on prints kept on file with the Department of Business Affairs and Consumer Protection and the Office of the City Clerk.

Said privilege shall be constructed in accordance with plans and specifications approved by the Department of Planning and Development and Department of Transportation (Division of Project Development).

This grant of privilege in the public way shall be subject to the provisions of Section 10-28-015 and all other required provisions of the Municipal Code of Chicago.

The grantee shall pay to the City of Chicago as compensation for the privilege #1112763 herein granted the sum of zero (\$0.00) per annum in advance.

A 25% penalty will be added for payments received after due date.

The permit holder agrees to hold the City of Chicago harmless for any damage, relocation or replacement costs associated with damage, relocation or removal of private property caused by the City performing work in the public way.

Authority herein given and granted for a period of five (5) years from and after Date of Passage.

Alderman Scott Waguespack
Scott Waguespack 32nd Ward

ROSCOE VILLAGE CHAMBER OF COMMERCE

ADDRESS: 2200 W BELMONT

LANDSCAPING PROGRAM 2014
(NOT TO SCALE)

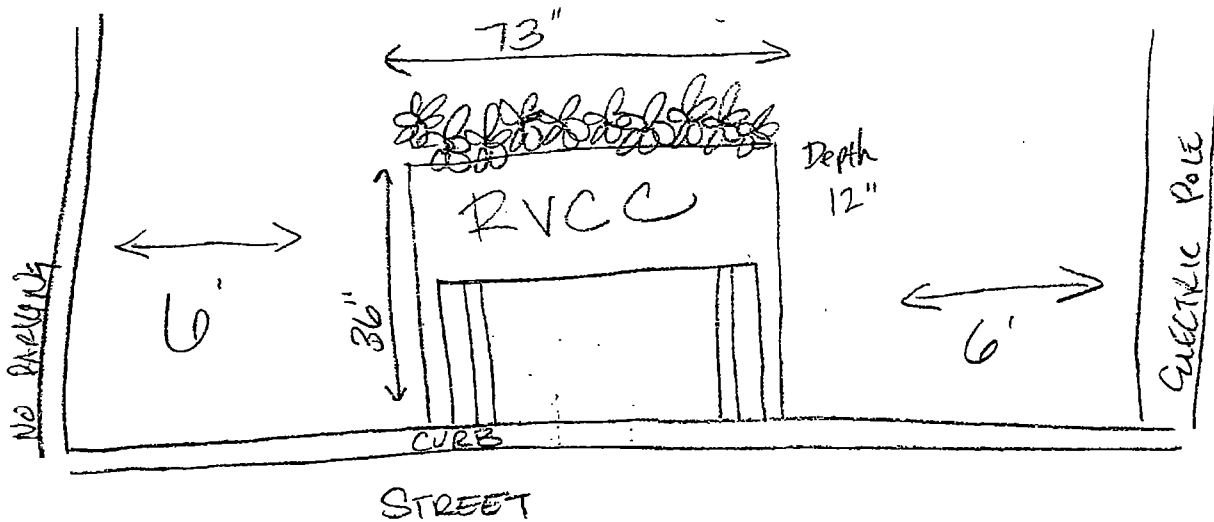
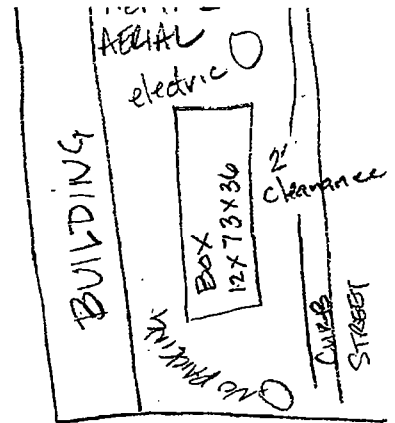



05/28/2014

Alderman **Scott Waguespack**
Ward # **32**
City of Chicago
City Hall, Room **300**
121 North LaSalle Street
Chicago, Illinois 60602

Re: An ordinance to use and maintain a portion of the public right-of-way for **one (1) planter(s)** for **Roscoe Village Chamber of Commerce**, adjacent to the premises known as **2200 W. Belmont Ave.**.

Dear Alderman **Scott Waguespack**:

The applicant referenced above has requested the use of the public right-of-way for a **planter(s)**. An ordinance has been prepared by the Department of Business Affairs and Consumer Protection – Small Business Center - Public Way Use Unit for presentation to the City Council. Because this request was made for properties located in your ward, as approved by you as per the attached, I respectfully request that you introduce the attached ordinance at the next City Council meeting.

If you have any questions regarding this ordinance, please contact Anthony Bertuca at (312) 744-5506.

Department of Business Affairs and Consumer Protection



City of Chicago



O2014-4547

Office of the City Clerk

Document Tracking Sheet

| | |
|---------------------------------|--|
| Meeting Date: | 5/28/2014 |
| Sponsor(s): | Waguespack (32) |
| Type: | Ordinance |
| Title: | Grant(s) of privilege in public way for Roscoe Village Chamber of Commerce - 2300 W Belmont Ave |
| Committee(s) Assignment: | Committee on Transportation and Public Way |

ORDINANCE
Roscoe Village Chamber of Commerce
Acct. No. 389975 - 6
Permit No. 1112764

Be It Ordained by the City Council of the City of Chicago:

SECTION 1. Permission and authority are hereby given and granted to Roscoe Village Chamber of Commerce, upon the terms and subject to the conditions of this ordinance to construct, install, maintain and use one (1) Planter(s) on the public right-of-way for beautification purposes adjacent to its premises known as 2300 W. Belmont Ave..

Said Planter(s) at W. Belmont measure(s):

One (1) at six point zero eight (6.08) feet in length, and one (1) foot in width for a total of six point zero eight (6.08) square feet.

Grantee must allow the required clear and unobstructed space for pedestrian passage at all times per rules and regulations approved by the Department of Transportation.

The location of said privilege shall be as shown on prints kept on file with the Department of Business Affairs and Consumer Protection and the Office of the City Clerk.

Said privilege shall be constructed in accordance with plans and specifications approved by the Department of Planning and Development and Department of Transportation (Division of Project Development).

This grant of privilege in the public way shall be subject to the provisions of Section 10-28-015 and all other required provisions of the Municipal Code of Chicago.

The grantee shall pay to the City of Chicago as compensation for the privilege #1112764 herein granted the sum of zero (\$.00) per annum in advance.

A 25% penalty will be added for payments received after due date.

The permit holder agrees to hold the City of Chicago harmless for any damage, relocation or replacement costs associated with damage, relocation or removal of private property caused by the City performing work in the public way.

Authority herein given and granted for a period of five (5) years from and after Date of Passage.

Alderman 
Scott Waguespack 32nd Ward

Handwritten scribbles or marks, possibly illegible text or a signature.

ROSCOE VILLAGE CHAMBER OF COMMERCE

ADDRESS: 2200 W BELMONT

LANDSCAPING PROGRAM 2014

(NOT TO SCALE)

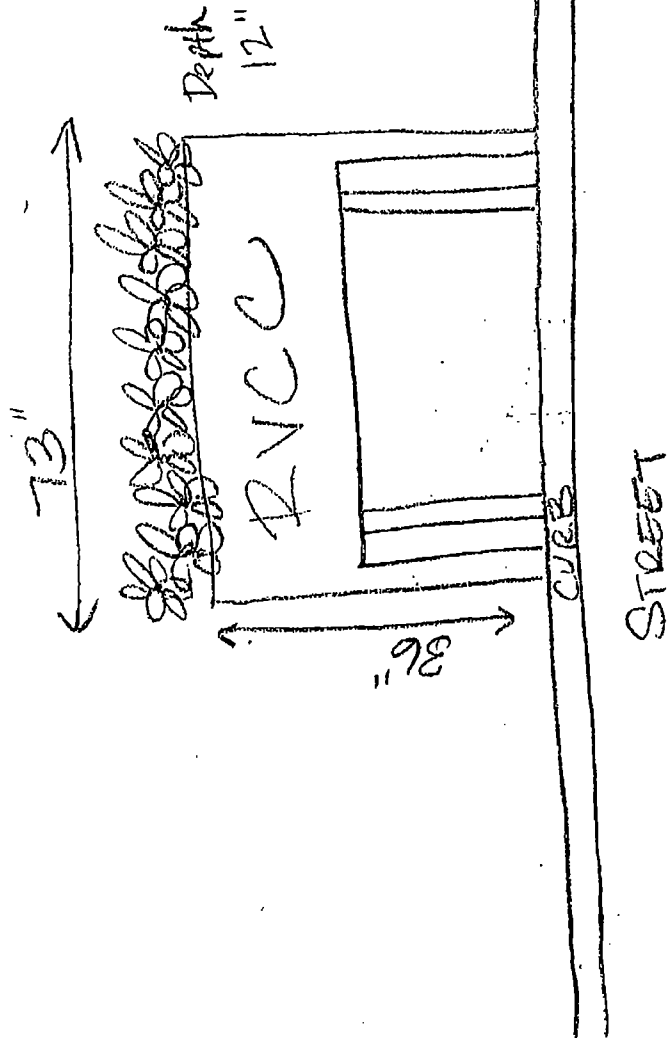
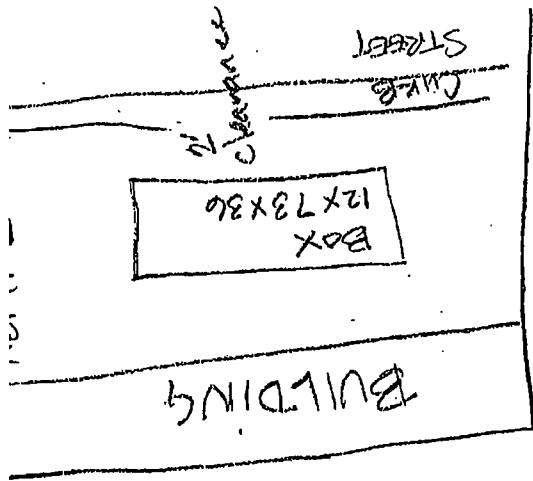



Department of Business Affairs and Consumer Protection
Small Business Center- Public Way Use Unit
City Hall- 121 N LaSalle Street Room 800 • Chicago, IL 60602
(312)-74-GOBIZ (312-744-6249) • (312) 744-1944 (TTY)
<http://www.cityofchicago.org/bacp>

05/28/2014

Alderman Scott Waguespack
Ward # 32
City of Chicago
City Hall, Room 300
121 North LaSalle Street
Chicago, Illinois 60602

Re: An ordinance to use and maintain a portion of the public right-of-way for **one (1) planter(s)** for **Roscoe Village Chamber of Commerce**, adjacent to the premises known as **2300 W. Belmont Ave.**.

Dear Alderman **Scott Waguespack**:

The applicant referenced above has requested the use of the public right-of-way for a **planter(s)**. An ordinance has been prepared by the Department of Business Affairs and Consumer Protection – Small Business Center - Public Way Use Unit for presentation to the City Council. Because this request was made for properties located in your ward, as approved by you as per the attached, I respectfully request that you introduce the attached ordinance at the next City Council meeting.

If you have any questions regarding this ordinance, please contact Anthony Bertuca at (312) 744-5506.

Department of Business Affairs and Consumer Protection



City of Chicago



O2014-4550

Office of the City Clerk

Document Tracking Sheet

| | |
|---------------------------------|--|
| Meeting Date: | 5/28/2014 |
| Sponsor(s): | Waguespack (32) |
| Type: | Ordinance |
| Title: | Grant(s) of privilege in public way for Roscoe Village Chamber of Commerce - 2332 W Belmont Ave |
| Committee(s) Assignment: | Committee on Transportation and Public Way |

ORDINANCE

Roscoe Village Chamber of Commerce
Acct. No. 389975 - 9
Permit No. 1112800

Be It Ordained by the City Council of the City of Chicago:

SECTION 1. Permission and authority are hereby given and granted to Roscoe Village Chamber of Commerce, upon the terms and subject to the conditions of this ordinance to construct, install, maintain and use one (1) Planter(s) on the public right-of-way for beautification purposes adjacent to its premises known as 2332 W. Belmont Ave..

Said Planter(s) at Belmont measure(s):

One (1) at six point zero eight (6.08) feet in length, and one (1) foot in width for a total of six point zero eight (6.08) square feet.

Grantee must allow the required clear and unobstructed space for pedestrian passage at all times per rules and regulations approved by the Department of Transportation.

The location of said privilege shall be as shown on prints kept on file with the Department of Business Affairs and Consumer Protection and the Office of the City Clerk.

Said privilege shall be constructed in accordance with plans and specifications approved by the Department of Planning and Development and Department of Transportation (Division of Project Development).

This grant of privilege in the public way shall be subject to the provisions of Section 10-28-015 and all other required provisions of the Municipal Code of Chicago.

The grantee shall pay to the City of Chicago as compensation for the privilege #1112800 herein granted the sum of zero (\$.00) per annum in advance.

A 25% penalty will be added for payments received after due date.

The permit holder agrees to hold the City of Chicago harmless for any damage, relocation or replacement costs associated with damage, relocation or removal of private property caused by the City performing work in the public way.

Authority herein given and granted for a period of five (5) years from and after Date of Passage.

Alderman 
Scott Waguespack 32nd Ward

10/10/10

ROSCOE VILLAGE CHAMBER OF COMMERCE

ADDRESS: 2332 W BELMONT

LANDSCAPING PROGRAM 2014

(NOT TO SCALE)

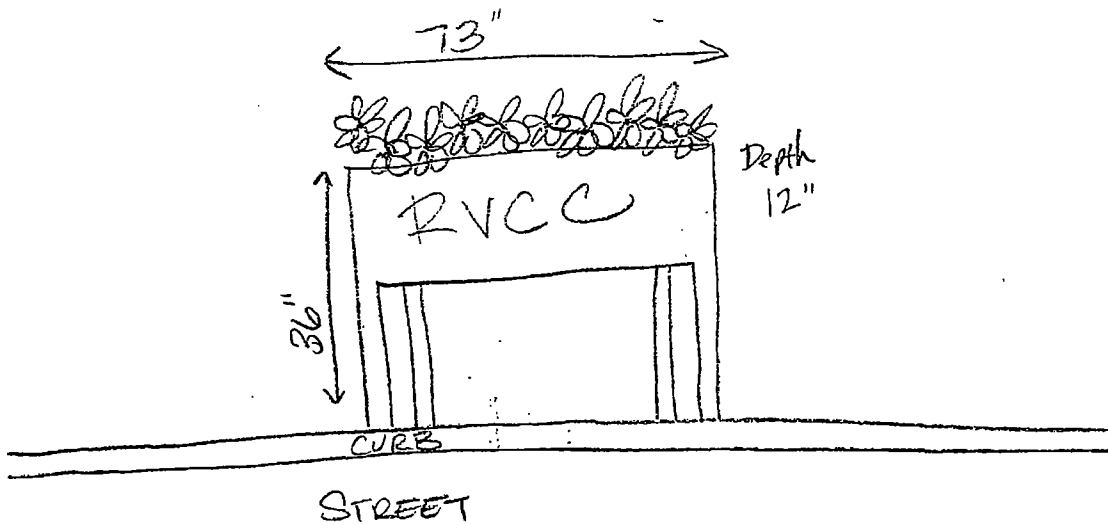
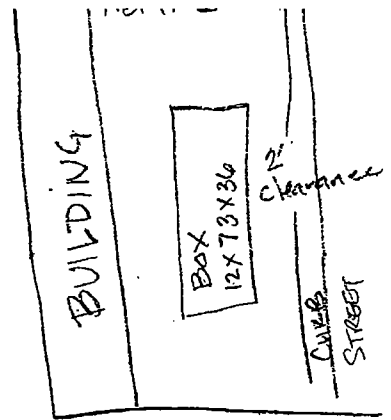



05/28/2014

Alderman **Scott Waguespack**
Ward # **32**
City of Chicago
City Hall, Room **300**
121 North LaSalle Street
Chicago, Illinois 60602

Re: An ordinance to use and maintain a portion of the public right-of-way for **one (1) planter(s)** for **Roscoe Village Chamber of Commerce**, adjacent to the premises known as **2332 W. Belmont Ave.**.

Dear Alderman **Scott Waguespack**:

The applicant referenced above has requested the use of the public right-of-way for a **planter(s)**. An ordinance has been prepared by the Department of Business Affairs and Consumer Protection – Small Business Center - Public Way Use Unit for presentation to the City Council. Because this request was made for properties located in your ward, as approved by you as per the attached, I respectfully request that you introduce the attached ordinance at the next City Council meeting.

If you have any questions regarding this ordinance, please contact Anthony Bertuca at (312) 744-5506.

Department of Business Affairs and Consumer Protection



City of Chicago



O2014-4553

Office of the City Clerk

Document Tracking Sheet

| | |
|---------------------------------|---|
| Meeting Date: | 5/28/2014 |
| Sponsor(s): | Waguespack (32) |
| Type: | Ordinance |
| Title: | Grant(s) of privilege in public way for Shigeyo Henriquez |
| Committee(s) Assignment: | Committee on Transportation and Public Way |

ORDINANCE
SHIGEYO HENRIQUEZ
Acct. No. 358662 - 1
Permit No. 1111263

Be It Ordained by the City Council of the City of Chicago:

SECTION 1. Permission and authority are hereby given and granted to SHIGEYO HENRIQUEZ, upon the terms and subject to the conditions of this ordinance to maintain and use, as now constructed, three (3) Stone Copings(s) (limestone/cornerstone) at base of building façade projecting over the public right-of-way adjacent to its premises known as 2223 W. Roscoe St..

Said Stone Copings(s) (limestone/cornerstone) at W Roscoe St measure(s):

One (1) at one point six two (1.62) foot in length, and point three one (.31) feet in width for a total of point five (.5) square feet.

One (1) at six point zero eight (6.08) feet in length, and point three one (.31) feet in width for a total of one point eight eight (1.88) square feet.

One (1) at one point three eight (1.38) foot in length, and point three one (.31) feet in width for a total of point four three (.43) square feet.

The location of said privilege shall be as shown on prints kept on file with the Department of Business Affairs and Consumer Protection and the Office of the City Clerk.

Said privilege shall be constructed in accordance with plans and specifications approved by the Department of Planning and Development and Department of Transportation (Division of Project Development).

This grant of privilege in the public way shall be subject to the provisions of Section 10-28-015 and all other required provisions of the Municipal Code of Chicago.

The grantee shall pay to the City of Chicago as compensation for the privilege #1111263 herein granted the sum of four hundred (\$400.00) per annum in advance.

A 25% penalty will be added for payments received after due date.

The permit holder agrees to hold the City of Chicago harmless for any damage, relocation or replacement costs associated with damage, relocation or removal of private property caused by the City performing work in the public way.

Authority herein given and granted for a period of five (5) years from and after 01/13/2014.

Alderman 
Scott Waguespack 32nd Ward



(200)

(200)

(200)

(200)

(200)



05/28/2014

Alderman Scott Waguespack
Ward # **32**
City of Chicago
City Hall, Room **300**
121 North LaSalle Street
Chicago, Illinois 60602

Re: An ordinance to use and maintain a portion of the public right-of-way for **three (3) stone copings(s)** for **SHIGEYO HENRIQUEZ**, adjacent to the premises known as **2223 W. Roscoe St.**

Dear **Alderman Scott Waguespack**:

The applicant referenced above has requested the use of the public right-of-way for a **stone copings(s)**. An ordinance has been prepared by the Department of Business Affairs and Consumer Protection – Small Business Center - Public Way Use Unit for presentation to the City Council. Because this request was made for properties located in your ward, as approved by you as per the attached, I respectfully request that you introduce the attached ordinance at the next City Council meeting.

If you have any questions regarding this ordinance, please contact Anthony Bertuca at (312) 744-5506.

Department of Business Affairs and Consumer Protection



City of Chicago



O2014-4556

Office of the City Clerk

Document Tracking Sheet

| | |
|---------------------------------|---|
| Meeting Date: | 5/28/2014 |
| Sponsor(s): | Waguespack (32) |
| Type: | Ordinance |
| Title: | Grant(s) of privilege in public way for Sixteen Condo Assn. |
| Committee(s) Assignment: | Committee on Transportation and Public Way |

ORDINANCE
Sixteen Condo Association
Acct. No. 340001 - 1
Permit No. 1112819

Be It Ordained by the City Council of the City of Chicago:

SECTION 1. Permission and authority are hereby given and granted to Sixteen Condo Association, upon the terms and subject to the conditions of this ordinance to maintain and use, as now constructed, nine (9) Balcony(s) projecting over the public right-of-way adjacent to its premises known as 3443 N. Lincoln Ave..

Said Balcony(s) at N Lincoln Ave measure(s):

One (1) at three (3) feet in length, and nine point seven five (9.75) feet in width for a total of twenty-nine point two five (29.25) square feet.

One (1) at three (3) feet in length, and twelve point seven four (12.74) feet in width for a total of thirty-eight point two two (38.22) square feet.

One (1) at three (3) feet in length, and nine point seven four (9.74) feet in width for a total of twenty-nine point two two (29.22) square feet.

One (1) at three (3) feet in length, and nine point seven five (9.75) feet in width for a total of twenty-nine point two five (29.25) square feet.

One (1) at three (3) feet in length, and twelve point seven four (12.74) feet in width for a total of thirty-eight point two two (38.22) square feet.

One (1) at three (3) feet in length, and nine point seven four (9.74) feet in width for a total of twenty-nine point two two (29.22) square feet.

One (1) at three (3) feet in length, and nine point seven five (9.75) feet in width for a total of twenty-nine point two five (29.25) square feet.

One (1) at three (3) feet in length, and nine point seven four (9.74) feet in width for a total of twenty-nine point two two (29.22) square feet.

One (1) at three (3) feet in length, and twelve point seven four (12.74) feet in width for a total of thirty-eight point two two (38.22) square feet.

The location of said privilege shall be as shown on prints kept on file with the Department of Business Affairs and Consumer Protection and the Office of the City Clerk.

Said privilege shall be constructed in accordance with plans and specifications approved by the Department of Planning and Development and Department of Transportation (Division of Project Development).

This grant of privilege in the public way shall be subject to the provisions of Section 10-28-015 and all other required provisions of the Municipal Code of Chicago.

The grantee shall pay to the City of Chicago as compensation for the privilege #1112819 herein granted the sum of six hundred seventy-five (\$675.00) per annum in advance.

A 25% penalty will be added for payments received after due date.

The permit holder agrees to hold the City of Chicago harmless for any damage, relocation or replacement costs associated with damage, relocation or removal of private property caused by the City performing work in the public way.

Authority herein given and granted for a period of five (5) years from and after 04/22/2014.

Alderman 

Scott Waguespack 32nd Ward

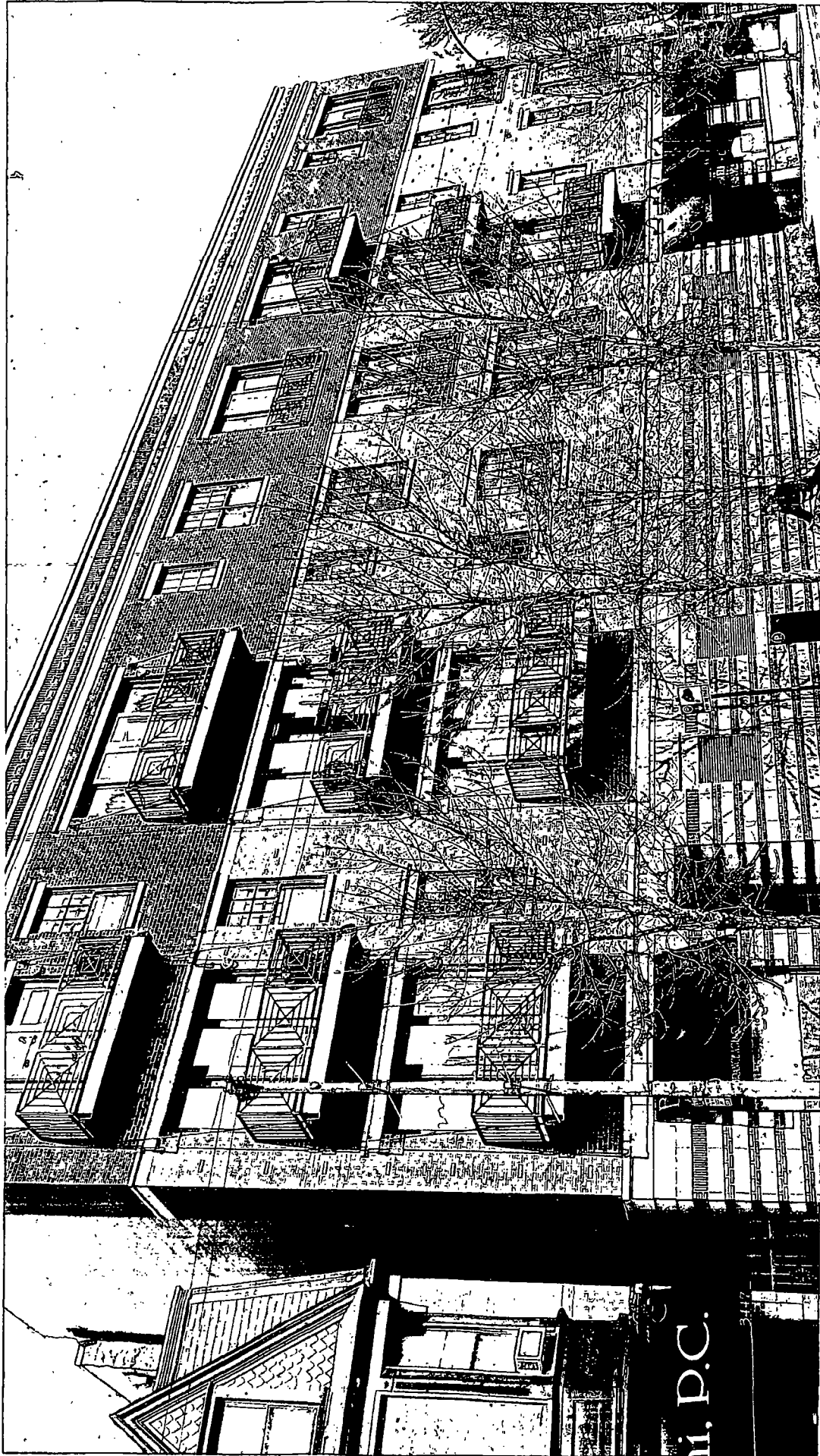



05/28/2014

Alderman **Scott Waguespack**
Ward # **32**
City of Chicago
City Hall, Room **300**
121 North LaSalle Street
Chicago, Illinois 60602

Re: An ordinance to use and maintain a portion of the public right-of-way for **nine (9) balcony(ies)** for **Sixteen Condo Association**, adjacent to the premises known as **3443 N. Lincoln Ave.**.

Dear Alderman **Scott Waguespack**:

The applicant referenced above has requested the use of the public right-of-way for a **balcony(ies)**. An ordinance has been prepared by the Department of Business Affairs and Consumer Protection – Small Business Center - Public Way Use Unit for presentation to the City Council. Because this request was made for properties located in your ward, as approved by you as per the attached, I respectfully request that you introduce the attached ordinance at the next City Council meeting.

If you have any questions regarding this ordinance, please contact Anthony Bertuca at (312) 744-5506.

Department of Business Affairs and Consumer Protection



City of Chicago



O2014-4563

Office of the City Clerk

Document Tracking Sheet

| | |
|---------------------------------|---|
| Meeting Date: | 5/28/2014 |
| Sponsor(s): | Waguespack (32) |
| Type: | Ordinance |
| Title: | Grant(s) of privilege in public way for Visual Cast Media |
| Committee(s) Assignment: | Committee on Transportation and Public Way |

ORDINANCE
Visual Cast Media
Acct. No. 22064 - 6
Permit No. 1107255

Be It Ordained by the City Council of the City of Chicago:

SECTION 1. Permission and authority are hereby given and granted to Visual Cast Media, upon the terms and subject to the conditions of this ordinance to maintain and use, as now constructed, one (1) Security Camera(s) projecting over the public right-of-way for security purposes adjacent to its premises known as 2000 W. Chicago Ave..

Said Security Camera(s) at Chicago measure(s):

One (1) at six (6) feet in length, point five eight (.58) feet in width and fourteen (14) feet above grade level.

The location of said privilege shall be as shown on prints kept on file with the Department of Business Affairs and Consumer Protection and the Office of the City Clerk.

Said privilege shall be constructed in accordance with plans and specifications approved by the Department of Planning and Development and Department of Transportation (Division of Project Development).

This grant of privilege in the public way shall be subject to the provisions of Section 10-28-015 and all other required provisions of the Municipal Code of Chicago.

The grantee shall pay to the City of Chicago as compensation for the privilege #1107255 herein granted the sum of zero (\$.00) per annum in advance.

A 25% penalty will be added for payments received after due date.

The permit holder agrees to hold the City of Chicago harmless for any damage, relocation or replacement costs associated with damage, relocation or removal of private property caused by the City performing work in the public way.

Authority herein given and granted for a period of five (5) years from and after Date of Passage.

Alderman 
Scott Waguespack 32nd Ward

Handwritten signature or scribble.



05/28/2014

Alderman **Scott Waguespack**
Ward # **32**
City of Chicago
City Hall, Room **300**
121 North LaSalle Street
Chicago, Illinois 60602

Re: An ordinance to use and maintain a portion of the public right-of-way for **one (1) security camera(s)** for **Visual Cast Media**, adjacent to the premises known as **2000 W. Chicago Ave.**.

Dear Alderman **Scott Waguespack**:

The applicant referenced above has requested the use of the public right-of-way for a **security camera(s)**. An ordinance has been prepared by the Department of Business Affairs and Consumer Protection – Small Business Center - Public Way Use Unit for presentation to the City Council. Because this request was made for properties located in your ward, as approved by you as per the attached, I respectfully request that you introduce the attached ordinance at the next City Council meeting.

If you have any questions regarding this ordinance, please contact Anthony Bertuca at (312) 744-5506.

Department of Business Affairs and Consumer Protection



City of Chicago



O2014-4568

Office of the City Clerk

Document Tracking Sheet

| | |
|---------------------------------|---|
| Meeting Date: | 5/28/2014 |
| Sponsor(s): | Mell (33) |
| Type: | Ordinance |
| Title: | Grant(s) of privilege in public way for Elston Ace Hardware, Inc. |
| Committee(s) Assignment: | Committee on Transportation and Public Way |

ORDINANCE
ELSTON ACE HARDWARE INC
Acct. No. 3272 - 1
Permit No. 1112272

Be It Ordained by the City Council of the City of Chicago:

SECTION 1. Permission and authority are hereby given and granted to ELSTON ACE HARDWARE INC, upon the terms and subject to the conditions of this ordinance to maintain and use, as now constructed, one (1) Building Projection over the public right-of-way adjacent to its premises known as 2825 W. Belmont Ave. .

Said Building Projection(s) at W. Belmont Ave measure(s):

One (1) at ninety-eight point six seven (98.67) feet in length, and one point two five (1.25) foot in width for a total of one hundred twenty-three point three four (123.34) square feet. Existing building projection is approximately seven (7) feet five (5) inches above grade level.

The location of said privilege shall be as shown on prints kept on file with the Department of Business Affairs and Consumer Protection and the Office of the City Clerk.

Said privilege shall be constructed in accordance with plans and specifications approved by the Department of Planning and Development and Department of Transportation (Division of Project Development).

This grant of privilege in the public way shall be subject to the provisions of Section 10-28-015 and all other required provisions of the Municipal Code of Chicago.

The grantee shall pay to the City of Chicago as compensation for the privilege #1112272 herein granted the sum of four hundred (\$400.00) per annum in advance.

A 25% penalty will be added for payments received after due date.

The permit holder agrees to hold the City of Chicago harmless for any damage, relocation or replacement costs associated with damage, relocation or removal of private property caused by the City performing work in the public way.

Authority herein given and granted for a period of five (5) years from and after 03/18/2014.

Alderman

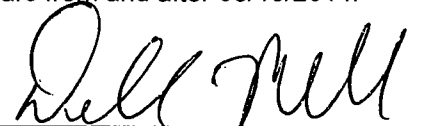

Deborah Mell 33rd Ward



95' 8" or 1,140" Length

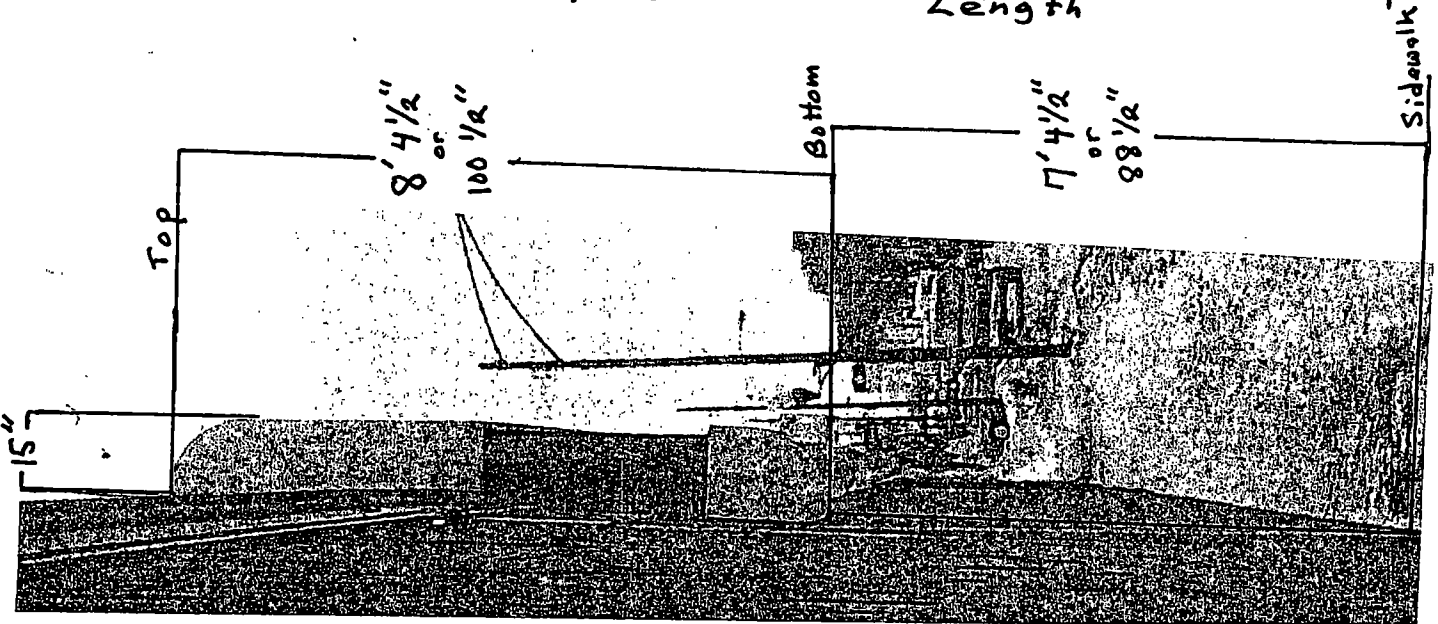



05/28/2014

Alderman Deborah Mell
Ward # 33
City of Chicago
City Hall, Room 208
121 North LaSalle Street
Chicago, Illinois 60602

Re: An ordinance to use and maintain a portion of the public right-of-way for **one (1) building projection(s)** for **ELSTON ACE HARDWARE INC**, adjacent to the premises known as **2825 W. Belmont Ave.**.

Dear Alderman **Deborah Mell**:

The applicant referenced above has requested the use of the public right-of-way for a **building projection(s)**. An ordinance has been prepared by the Department of Business Affairs and Consumer Protection – Small Business Center - Public Way Use Unit for presentation to the City Council. Because this request was made for properties located in your ward, as approved by you as per the attached, I respectfully request that you introduce the attached ordinance at the next City Council meeting.

If you have any questions regarding this ordinance, please contact Anthony Bertuca at (312) 744-5506.

Department of Business Affairs and Consumer Protection



City of Chicago



O2014-4571

Office of the City Clerk

Document Tracking Sheet

| | |
|---------------------------------|--|
| Meeting Date: | 5/28/2014 |
| Sponsor(s): | Mell (33) |
| Type: | Ordinance |
| Title: | Grant(s) of privilege in public way for Lincoln Antique Mall |
| Committee(s) Assignment: | Committee on Transportation and Public Way |

ORDINANCE
LINCOLN ANTIQUE MALL
Acct. No. 56627 - 3
Permit No. 1112993

Be It Ordained by the City Council of the City of Chicago:

SECTION 1. Permission and authority are hereby given and granted to LINCOLN ANTIQUE MALL, upon the terms and subject to the conditions of this ordinance to maintain and use one (1) sign(s) projecting over the public right-of-way attached to its premises known as 3115 W. Irving Park Rd..

Said sign structure(s) measures as follows; along W. Irving Park Road:
One (1) at eight point six seven (8.67) feet in length, five (5) feet in height and eleven point five (11.5) feet above grade level.

The location of said privilege shall be as shown on prints kept on file with the Department of Business Affairs and Consumer Protection and the Office of the City Clerk.

Said privilege shall be constructed in accordance with plans and specifications approved by the Department of Transportation (Division of Project Development) and Zoning Department - Signs.

This grant of privilege in the public way shall be subject to the provisions of Section 10-28-015 and all other required provisions of the Municipal Code of Chicago.

The grantee shall pay to the City of Chicago as compensation for the privilege #1112993 herein granted the sum of three hundred (\$300.00) per annum in advance.

A 25% penalty will be added for payments received after due date.

The permit holder agrees to hold the City of Chicago harmless for any damage, relocation or replacement costs associated with damage, relocation or removal of private property caused by the City performing work in the public way.

Authority herein given and granted for a period of five (5) years from and after 02/11/2014.

Alderman 

Deborah Mell 33rd Ward

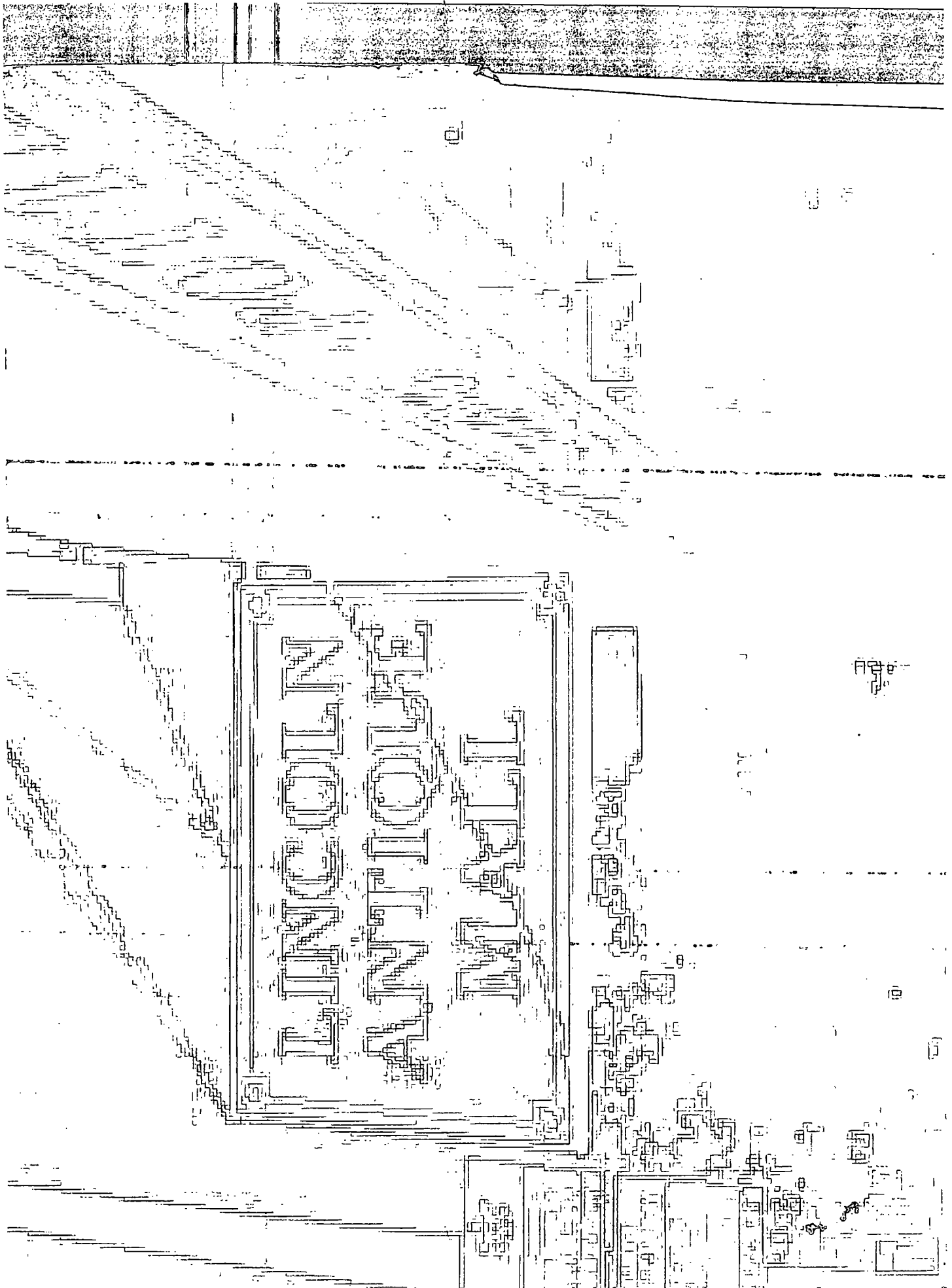



Department of Business Affairs and Consumer Protection

Small Business Center - Public Way Use Unit

City Hall - 121 N. LaSalle Street, Room 800 • Chicago, IL 60602

(312)-74-GOBIZ (312-744-6249) • (312) 744-1944 (TTY)

<http://www.cityofchicago.org/bacp>

05/28/2014

Alderman **Deborah Mell**

Ward # **33**

City of Chicago

City Hall, Room **208**

121 North LaSalle Street

Chicago, Illinois 60602

Re: An ordinance to use and maintain a portion of the public right-of-way for **one (1) sign(s)** for
LINCOLN ANTIQUE MALL, adjacent to the premises known as **3115 W. Irving Park Rd.**

Dear Alderman **Deborah Mell**:

The applicant referenced above has requested the use of the public right-of-way for a **sign(s)**. An ordinance has been prepared by the Department of Business Affairs and Consumer Protection – Small Business Center - Public Way Use Unit for presentation to the City Council. Because this request was made for properties located in your ward, as approved by you as per the attached, I respectfully request that you introduce the attached ordinance at the next City Council meeting.

If you have any questions regarding this ordinance, please contact Anthony Bertuca at (312) 744-5506.

Department of Business Affairs and Consumer Protection



City of Chicago



O2014-4575

Office of the City Clerk

Document Tracking Sheet

| | |
|---------------------------------|---|
| Meeting Date: | 5/28/2014 |
| Sponsor(s): | Mell (33) |
| Type: | Ordinance |
| Title: | Grant(s) of privilege in public way for North Park University |
| Committee(s) Assignment: | Committee on Transportation and Public Way |

ORDINANCE
NORTH PARK UNIVERSITY
Acct. No. 88250 - 1
Permit No. 1110943

Be It Ordained by the City Council of the City of Chicago:

SECTION 1. Permission and authority are hereby given and granted to NORTH PARK UNIVERSITY, upon the terms and subject to the conditions of this ordinance to maintain and occupy a portion of the public right-of-way along North Albany Avenue adjacent to its premises known as 5137 North Albany Avenue. Existing occupation of space consist of green space along the east side of North Albany Avenue fencing, two (2) dugouts, a retaining wall, three light poles viewing stands all or portions which encumber in the public way a total of three thousand seven hundred eight (3,708) square feet.

The location of said privilege shall be as shown on prints kept on file with the Department of Business Affairs and Consumer Protection and the Office of the City Clerk.

Said privilege shall be constructed in accordance with plans and specifications approved by the Department of Planning and Development, Department of Transportation (Division of Project Development), and Department of Transportation (Office of Underground Coordination).

This grant of privilege in the public way shall be subject to the provisions of Section 10-28-015 and all other required provisions of the Municipal Code of Chicago.

The grantee shall pay to the City of Chicago as compensation for the privilege #1110943 herein granted the sum of four thousand four hundred thirty-eight (\$4,438.00) per annum in advance.

A 25% penalty will be added for payments received after due date.

The permit holder agrees to hold the City of Chicago harmless for any damage, relocation or replacement costs associated with damage, relocation or removal of private property caused by the City performing work in the public way.

Authority herein given and granted for a period of five (5) years from and after 11/05/2013.

Alderman

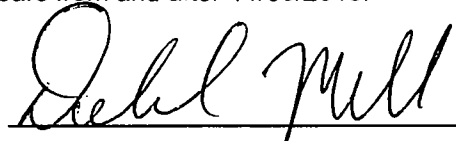

Deborah Mell 33rd Ward

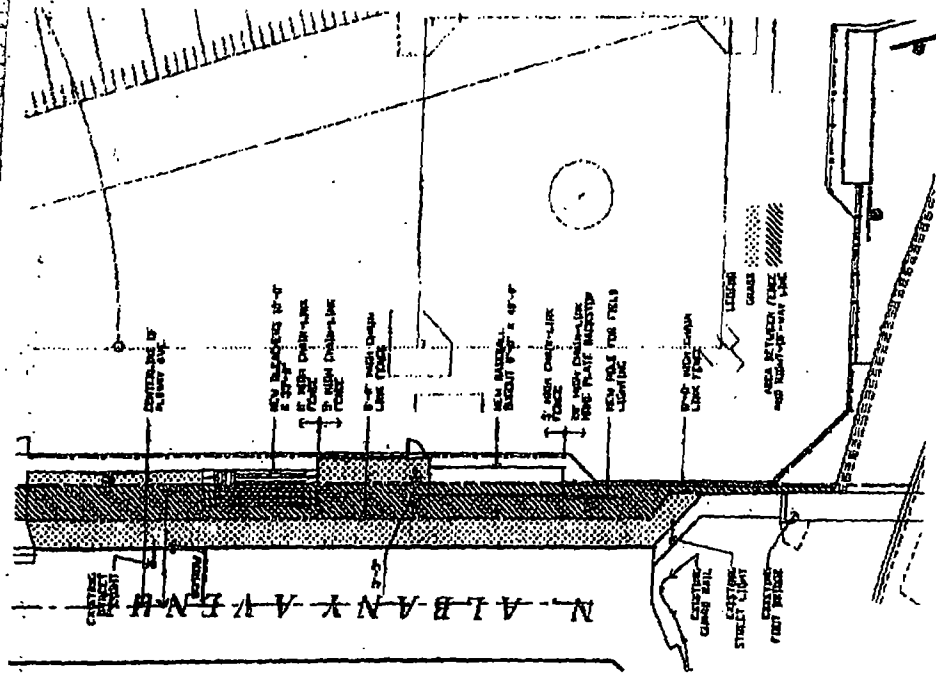

N ALBANY AVENUE

EXISTING CURB MAIL
EXISTING STREET LIGHT
EXISTING FRONT PORCH



05/28/2014

Alderman Deborah Mell
Ward # 33
City of Chicago
City Hall, Room 208
121 North LaSalle Street
Chicago, Illinois 60602

Re: An ordinance to use and maintain a portion of the public right-of-way for **one (1) occupation of space(s)** for **NORTH PARK UNIVERSITY**, adjacent to the premises known as **5137 N. Albany Ave.**.

Dear Alderman **Deborah Mell**:

The applicant referenced above has requested the use of the public right-of-way for a **occupation of space(s)**. An ordinance has been prepared by the Department of Business Affairs and Consumer Protection – Small Business Center - Public Way Use Unit for presentation to the City Council. Because this request was made for properties located in your ward, as approved by you as per the attached, I respectfully request that you introduce the attached ordinance at the next City Council meeting.

If you have any questions regarding this ordinance, please contact Anthony Bertuca at (312) 744-5506.

Department of Business Affairs and Consumer Protection



City of Chicago



O2014-4583

Office of the City Clerk

Document Tracking Sheet

| | |
|---------------------------------|---|
| Meeting Date: | 5/28/2014 |
| Sponsor(s): | Mell (33) |
| Type: | Ordinance |
| Title: | Grant(s) of privilege in public way for North River Commission |
| Committee(s) Assignment: | Committee on Transportation and Public Way |

ORDINANCE
NORTH RIVER COMMISSION
Acct. No. 386597 - 1
Permit No. 1109702

Be It Ordained by the City Council of the City of Chicago:

SECTION 1. Permission and authority are hereby given and granted to NORTH RIVER COMMISSION, upon the terms and subject to the conditions of this ordinance to construct, install, maintain and use one (1) Kiosk(s) on the public right-of-way adjacent to its premises known as 3365 W. Lawrence Ave..

Said Kiosk(s) at W. Lawrence measure(s):

One (1) at three point five (3.5) feet in length, and three point five (3.5) feet in width for a total of twelve point two five (12.25) square feet. Said kiosk shall be approximately fourteen (14) feet in height.

The location of said privilege shall be as shown on prints kept on file with the Department of Business Affairs and Consumer Protection and the Office of the City Clerk.

Said privilege shall be constructed in accordance with plans and specifications approved by the Department of Transportation (Division of Project Development) and Zoning Department - Signs.

This grant of privilege in the public way shall be subject to the provisions of Section 10-28-015 and all other required provisions of the Municipal Code of Chicago.

The grantee shall pay to the City of Chicago as compensation for the privilege #1109702 herein granted the sum of four hundred (\$400.00) per annum in advance.

A 25% penalty will be added for payments received after due date.

The permit holder agrees to hold the City of Chicago harmless for any damage, relocation or replacement costs associated with damage, relocation or removal of private property caused by the City performing work in the public way.

Authority herein given and granted for a period of five (5) years from and after Date of Passage.

Alderman

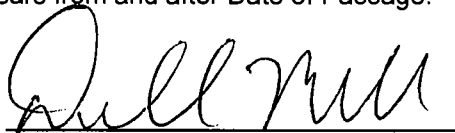

Deborah Mell 33rd Ward

17-271

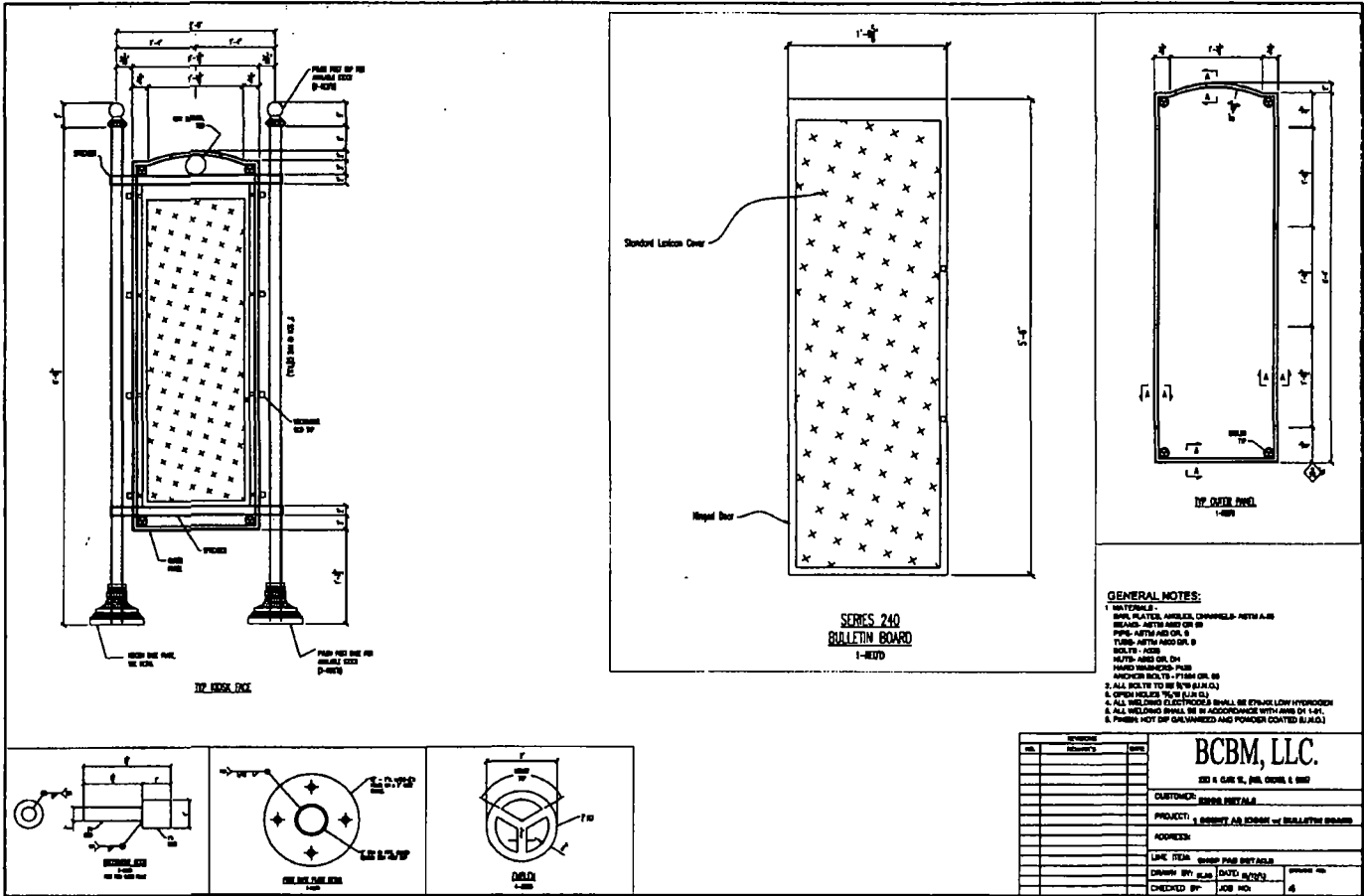



05/28/2014

Alderman Deborah Mell
Ward # **33**
City of Chicago
City Hall, Room **208**
121 North LaSalle Street
Chicago, Illinois 60602

Re: An ordinance to use and maintain a portion of the public right-of-way for **one (1) kiosk(s)** for
NORTH RIVER COMMISSION, adjacent to the premises known as **3365 W. Lawrence Ave.**

Dear Alderman **Deborah Mell**:

The applicant referenced above has requested the use of the public right-of-way for a **kiosk(s)**. An ordinance has been prepared by the Department of Business Affairs and Consumer Protection – Small Business Center - Public Way Use Unit for presentation to the City Council. Because this request was made for properties located in your ward, as approved by you as per the attached, I respectfully request that you introduce the attached ordinance at the next City Council meeting.

If you have any questions regarding this ordinance, please contact Anthony Bertuca at (312) 744-5506.

Department of Business Affairs and Consumer Protection



City of Chicago



O2014-4588

Office of the City Clerk

Document Tracking Sheet

| | |
|---------------------------------|--|
| Meeting Date: | 5/28/2014 |
| Sponsor(s): | Austin (34) |
| Type: | Ordinance |
| Title: | Grant(s) of privilege in public way for Express Food Mart & Cellular |
| Committee(s) Assignment: | Committee on Transportation and Public Way |

ORDINANCE
EXPRESS FOOD MART & CELLULAR
Acct. No. 354798 - 1
Permit No. 1096528

Be It Ordained by the City Council of the City of Chicago:

SECTION 1. Permission and authority are hereby given and granted to EXPRESS FOOD MART & CELLULAR, upon the terms and subject to the conditions of this ordinance to maintain and use two (2) sign(s) projecting over the public right-of-way attached to its premises known as 11058 S. Wentworth Ave..

Said sign structure(s) measures as follows; along S. Wenworth:
One (1) at ten point five (10.5) feet in length, eight point three three (8.33) feet in height and fifteen point five eight (15.58) feet above grade level.

Said sign structure(s) measures as follows; along S. Wenworth:
One (1) at ten point five (10.5) feet in length, four point five eight (4.58) feet in height and eleven (11) feet above grade level.

The location of said privilege shall be as shown on prints kept on file with the Department of Business Affairs and Consumer Protection and the Office of the City Clerk.

Said privilege shall be constructed in accordance with plans and specifications approved by the Department of Transportation (Division of Project Development) and Zoning Department - Signs.

This grant of privilege in the public way shall be subject to the provisions of Section 10-28-015 and all other required provisions of the Municipal Code of Chicago.

The grantee shall pay to the City of Chicago as compensation for the privilege #1096528 herein granted the sum of six hundred (\$600.00) per annum in advance.

A 25% penalty will be added for payments received after due date.

The permit holder agrees to hold the City of Chicago harmless for any damage, relocation or replacement costs associated with damage, relocation or removal of private property caused by the City performing work in the public way.

Authority herein given and granted for a period of five (5) years from and after Date of Passage.

Alderman Carrie M. Austin

Carrie M. Austin 34th Ward

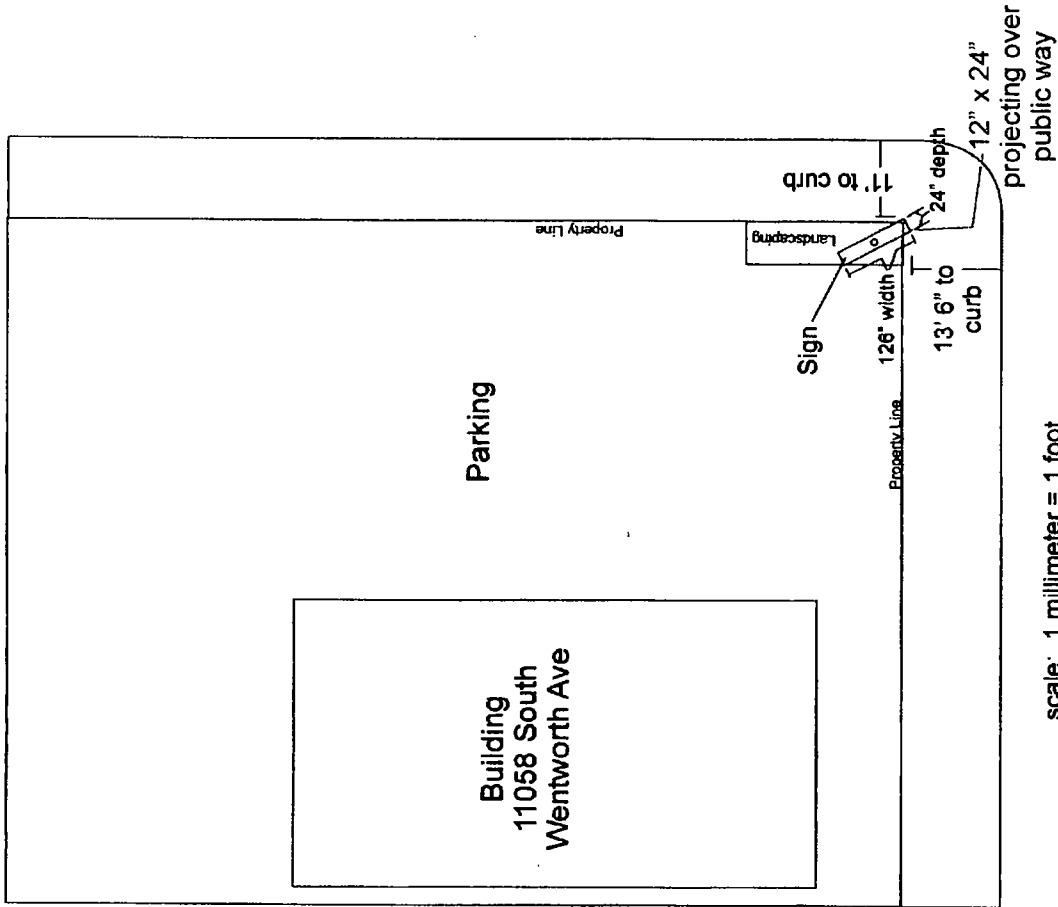

scale: 1 millimeter = 1 foot

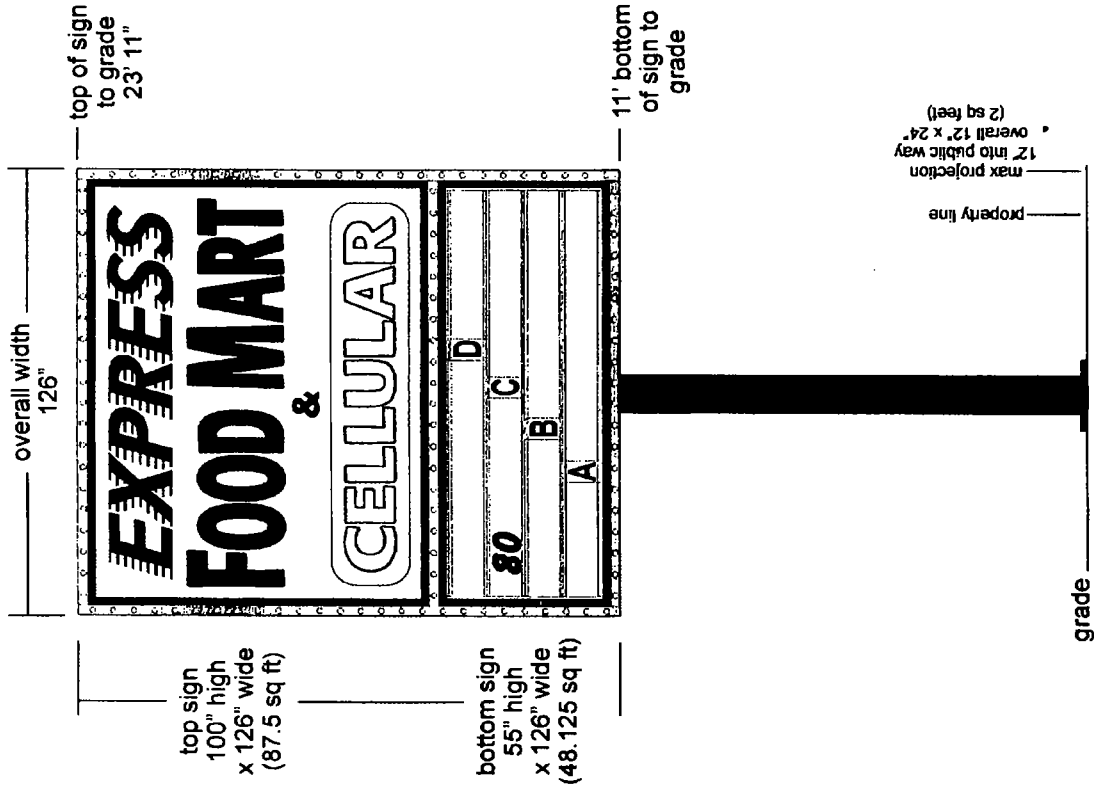

scale: 1 millimeter = 2 inches

Express Food Mart
11058 S. Wentworth Ave
Chicago, IL

ASAP Sign & Lighting Maint Inc
443 W US Highway 6; Valparaiso, IN 46385
Ken Richmond 312-718-8819



05/28/2014

Alderman **Carrie M. Austin**
Ward # **34**
City of Chicago
City Hall, Room **203**
121 North LaSalle Street
Chicago, Illinois 60602

Re: An ordinance to use and maintain a portion of the public right-of-way for **two (2) sign(s)** for **EXPRESS FOOD MART & CELLULAR**, adjacent to the premises known as **11058 S. Wentworth Ave.**.

Dear Alderman **Carrie M. Austin**:

The applicant referenced above has requested the use of the public right-of-way for a **sign(s)**. An ordinance has been prepared by the Department of Business Affairs and Consumer Protection – Small Business Center - Public Way Use Unit for presentation to the City Council. Because this request was made for properties located in your ward, as approved by you as per the attached, I respectfully request that you introduce the attached ordinance at the next City Council meeting.

If you have any questions regarding this ordinance, please contact Anthony Bertuca at (312) 744-5506.

Department of Business Affairs and Consumer Protection



City of Chicago



O2014-4595

Office of the City Clerk

Document Tracking Sheet

| | |
|---------------------------------|--|
| Meeting Date: | 5/28/2014 |
| Sponsor(s): | Austin (34) |
| Type: | Ordinance |
| Title: | Grant(s) of privilege in public way for Magic Johnson Bridgescape Academy |
| Committee(s) Assignment: | Committee on Transportation and Public Way |

ORDINANCE
MAGIC JOHNSON BRIDGESCAPE ACADEMY
Acct. No. 333578 - 4
Permit No. 1111692

Be It Ordained by the City Council of the City of Chicago:

SECTION 1. Permission and authority are hereby given and granted to MAGIC JOHNSON BRIDGESCAPE ACADEMY, upon the terms and subject to the conditions of this ordinance to maintain and use two (2) sign(s) projecting over the public right-of-way attached to its premises known as 10928 S. Halsted St..

Said sign structure(s) measures as follows; along S. Halsted Street:

One (1) at six (6) feet in length, nine point one seven (9.17) feet in height and nine (9) feet above grade level.

One (1) at eleven (11) feet in length, three point six seven (3.67) feet in height and fourteen (14) feet above grade level.

The location of said privilege shall be as shown on prints kept on file with the Department of Business Affairs and Consumer Protection and the Office of the City Clerk.

Said privilege shall be constructed in accordance with plans and specifications approved by the Department of Transportation (Division of Project Development) and Zoning Department - Signs.

This grant of privilege in the public way shall be subject to the provisions of Section 10-28-015 and all other required provisions of the Municipal Code of Chicago.

The grantee shall pay to the City of Chicago as compensation for the privilege #1111692 herein granted the sum of six hundred (\$600.00) per annum in advance.

A 25% penalty will be added for payments received after due date.

The permit holder agrees to hold the City of Chicago harmless for any damage, relocation or replacement costs associated with damage, relocation or removal of private property caused by the City performing work in the public way.

Authority herein given and granted for a period of five (5) years from and after Date of Passage.

Alderman Carrie M. Austin

Carrie M. Austin 34th Ward

REPLACEMENT

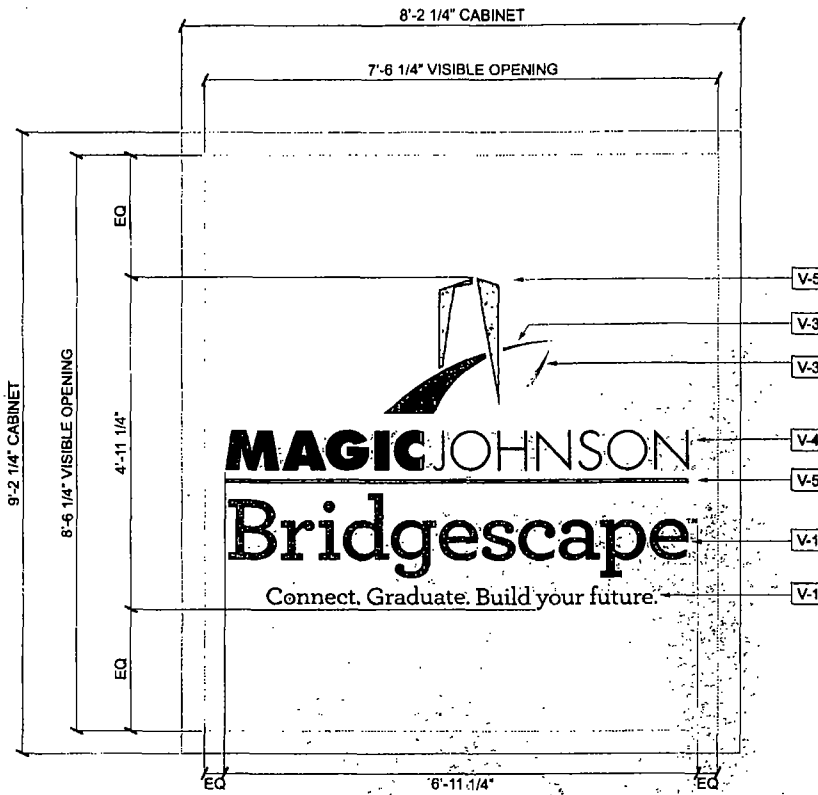

TYP. FRONT (B.1)

DETAILS (B.2)

NEW VINYL GRAPHICS / NEW FL

| | | |
|-----|-----------|--------|
| (A) | FACES | NEW |
| | MATERIAL | FLEX F |
| | COLOR | WHITE |
| (B) | RETAINERS | EXISTI |
| | SIZE: | 4" REV |

VINYL MATRIX

| | | |
|-----|---------|---------|
| V-1 | VINYL | H.P. BL |
| | FINISH | OPAQL |
| | APPLIED | 1ST SL |
| V-2 | VINYL | MATCH |
| | FINISH | TRANS |
| | APPLIED | 1ST SL |
| V-3 | VINYL | PROCI |
| | FINISH | TRANS |
| | APPLIED | 1ST SL |
| V-4 | VINYL | MATCH |
| | FINISH | TRANS |
| | APPLIED | 1ST SL |
| V-5 | VINYL | MATCH |
| | FINISH | TRANS |
| | APPLIED | 1ST SL |
| V-6 | VINYL | MATCH |
| | FINISH | TRANS |
| | APPLIED | 1ST SL |



05/28/2014

Alderman **Carrie M. Austin**
Ward # **34**
City of Chicago
City Hall, Room **203**
121 North LaSalle Street
Chicago, Illinois 60602

Re: An ordinance to use and maintain a portion of the public right-of-way for **two (2) sign(s)** for **MAGIC JOHNSON BRIDGESCAPE ACADEMY**, adjacent to the premises known as **10928 S. Halsted St.**

Dear Alderman **Carrie M. Austin**:

The applicant referenced above has requested the use of the public right-of-way for a **sign(s)**. An ordinance has been prepared by the Department of Business Affairs and Consumer Protection – Small Business Center - Public Way Use Unit for presentation to the City Council. Because this request was made for properties located in your ward, as approved by you as per the attached, I respectfully request that you introduce the attached ordinance at the next City Council meeting.

If you have any questions regarding this ordinance, please contact Anthony Bertuca at (312) 744-5506.

Department of Business Affairs and Consumer Protection



City of Chicago



O2014-4601

Office of the City Clerk

Document Tracking Sheet

| | |
|---------------------------------|---|
| Meeting Date: | 5/28/2014 |
| Sponsor(s): | Colón (35) |
| Type: | Ordinance |
| Title: | Grant(s) of privilege in public way for Cafe Con Leche D'Noche |
| Committee(s) Assignment: | Committee on Transportation and Public Way |

ORDINANCE
CAFE CON LECHE D' NOCHE
Acct. No. 246146 - 2
Permit No. 1111164

Be It Ordained by the City Council of the City of Chicago:

SECTION 1. Permission and authority are hereby given and granted to CAFE CON LECHE D' NOCHE, upon the terms and subject to the conditions of this ordinance to maintain and use, as now constructed, one (1) Wind Screen(s) on the public right-of-way adjacent to its premises known as 2710 N. Milwaukee Ave..

Said Wind Screen(s) at N Milwaukee Ave measure(s):

One (1) at four (4) feet in length, and four (4) feet in width for a total of sixteen (16) square feet.

The location of said privilege shall be as shown on prints kept on file with the Department of Business Affairs and Consumer Protection and the Office of the City Clerk.

Said privilege shall be constructed in accordance with plans and specifications approved by the Department of Transportation (Division of Project Development).

This grant of privilege in the public way shall be subject to the provisions of Section 10-28-015 and all other required provisions of the Municipal Code of Chicago.

The grantee shall pay to the City of Chicago as compensation for the privilege #1111164 herein granted the sum of four hundred (\$400.00) per annum in advance.

A 25% penalty will be added for payments received after due date.

The permit holder agrees to hold the City of Chicago harmless for any damage, relocation or replacement costs associated with damage, relocation or removal of private property caused by the City performing work in the public way.

Authority herein given and granted for a period of five (5) years from and after Date of Passage.

Alderman

Reynaldo Colon 35th Ward

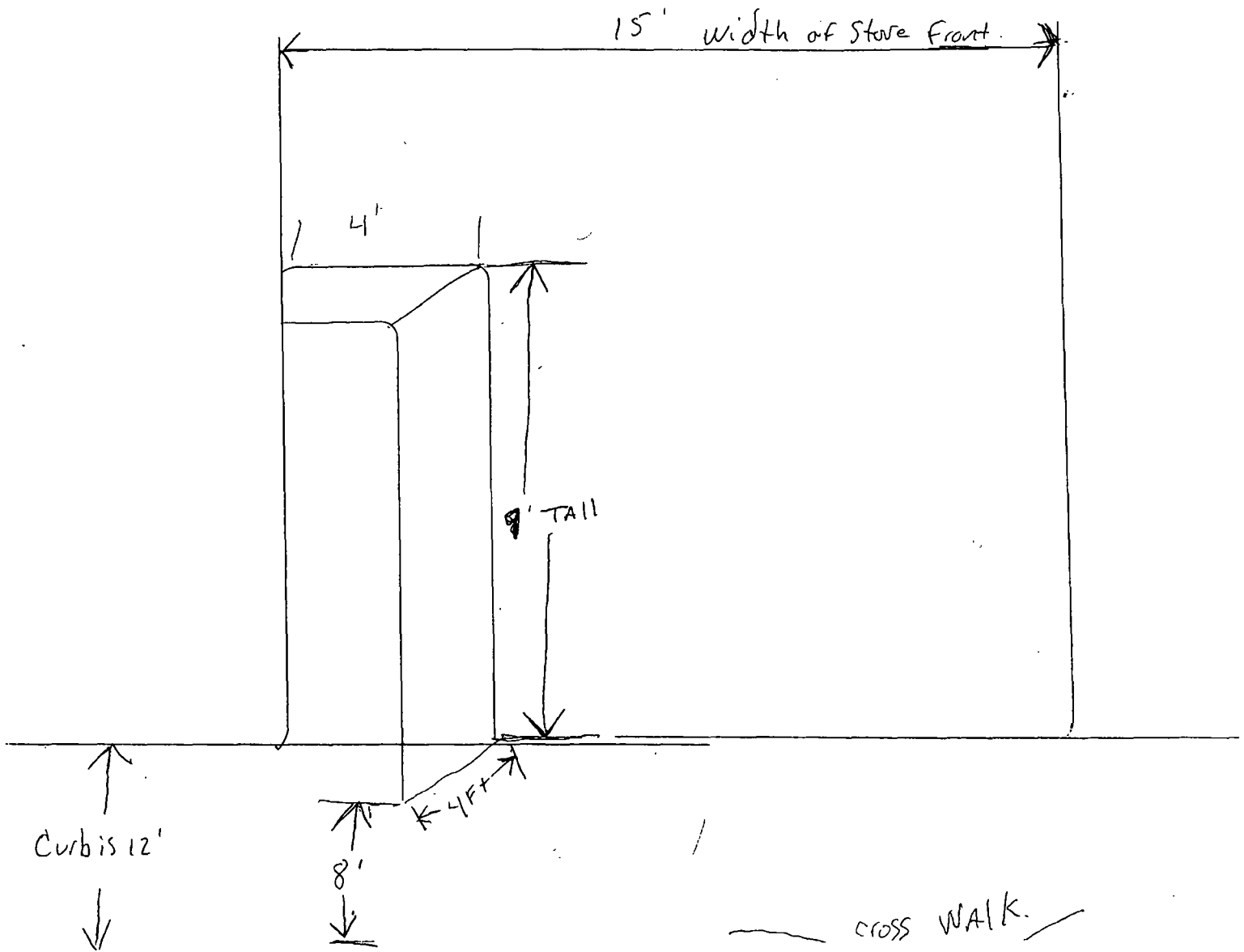



05/28/2014

Alderman **Reynaldo Colon**
Ward # **35**
City of Chicago
City Hall, Room **203**
121 North LaSalle Street
Chicago, Illinois 60602

Re: An ordinance to use and maintain a portion of the public right-of-way for **one (1) wind screen(s)** for **CAFE CON LECHE D' NOCHE**, adjacent to the premises known as **2710 N. Milwaukee Ave.**.

Dear Alderman **Reynaldo Colon**:

The applicant referenced above has requested the use of the public right-of-way for a **wind screen(s)**. An ordinance has been prepared by the Department of Business Affairs and Consumer Protection – Small Business Center - Public Way Use Unit for presentation to the City Council. Because this request was made for properties located in your ward, as approved by you as per the attached, I respectfully request that you introduce the attached ordinance at the next City Council meeting.

If you have any questions regarding this ordinance, please contact Anthony Bertuca at (312) 744-5506.

Department of Business Affairs and Consumer Protection



City of Chicago



O2014-4602

Office of the City Clerk

Document Tracking Sheet

| | |
|---------------------------------|---|
| Meeting Date: | 5/28/2014 |
| Sponsor(s): | Colón (35) |
| Type: | Ordinance |
| Title: | Grant(s) of privilege in public way for Fullerton Hotel |
| Committee(s) Assignment: | Committee on Transportation and Public Way |

ORDINANCE
FULLERTON HOTEL
Acct. No. 268166 - 1
Permit No. 1113081

Be It Ordained by the City Council of the City of Chicago:

SECTION 1. Permission and authority are hereby given and granted to FULLERTON HOTEL, upon the terms and subject to the conditions of this ordinance to maintain and use one (1) sign(s) projecting over the public right-of-way attached to its premises known as 3919 W. Fullerton Ave..

Said sign structure(s) measures as follows; along W. FULLERTON:

One (1) at four point six seven (4.67) feet in length, eight point seven five (8.75) feet in height and twenty-two point five (22.5) feet above grade level.

The location of said privilege shall be as shown on prints kept on file with the Department of Business Affairs and Consumer Protection and the Office of the City Clerk

Said privilege shall be constructed in accordance with plans and specifications approved by the Department of Transportation (Division of Project Development) and Zoning Department- Signs.

This grant of privilege in the public way shall be subject to the provisions of Section 10-28-015 and all other required provisions of the Municipal Code of Chicago.

The grantee shall pay to the City of Chicago as compensation for the privilege #1113081 herein granted the sum of three hundred (\$300.00) per annum in advance.

A 25% penalty will be added for payments received after due date

The permit holder agrees to hold the City of Chicago harmless for any damage, relocation or replacement costs associated with damage, relocation or removal of private property caused by the City performing work in the public way.

Authority herein given and granted for a period of five (5) years from and after 04/22/2014.

Alderman _____
Reynaldo Colon 35th Ward

Fullerton Hotel Sign Sketch

Address: 3919 W Fullerton Ave

Account#: 268166

Permit#: 1084556

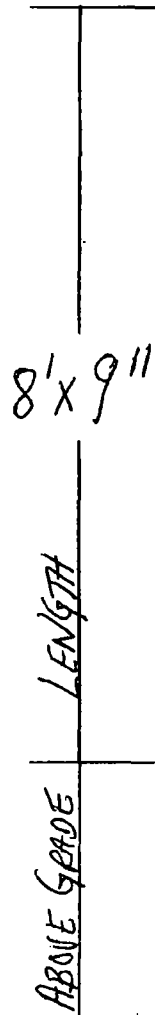
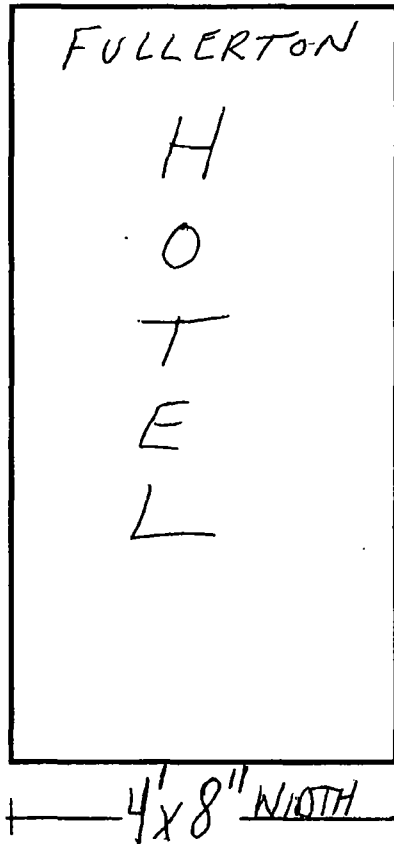

22' x 6"

SIDEWALK



05/28/2014

Alderman **Reynaldo Colon**
Ward # **35**
City of Chicago
City Hall, Room **203**
121 North LaSalle Street
Chicago, Illinois 60602

Re: An ordinance to use and maintain a portion of the public right-of-way for **one (1) sign(s)** for
FULLERTON HOTEL, adjacent to the premises known as **3919 W. Fullerton Ave.**

Dear Alderman **Reynaldo Colon**:

The applicant referenced above has requested the use of the public right-of-way for a **sign(s)**. An ordinance has been prepared by the Department of Business Affairs and Consumer Protection – Small Business Center - Public Way Use Unit for presentation to the City Council. Because this request was made for properties located in your ward, as approved by you as per the attached, I respectfully request that you introduce the attached ordinance at the next City Council meeting.

If you have any questions regarding this ordinance, please contact Anthony Bertuca at (312) 744-5506.

Department of Business Affairs and Consumer Protection



City of Chicago



O2014-4608

Office of the City Clerk

Document Tracking Sheet

| | |
|---------------------------------|---|
| Meeting Date: | 5/28/2014 |
| Sponsor(s): | Colón (35) |
| Type: | Ordinance |
| Title: | Grant(s) of privilege in public way for Kedzie Elston C.E., Inc. |
| Committee(s) Assignment: | Committee on Transportation and Public Way |

ORDINANCE
KEDZIE ELSTON C.E.,INC
Acct. No. 67380 - 1
Permit No. 1113148

Be It Ordained by the City Council of the City of Chicago:

SECTION 1. Permission and authority are hereby given and granted to KEDZIE ELSTON C.E.,INC, upon the terms and subject to the conditions of this ordinance to maintain and use one (1) sign(s) projecting over the public right-of-way attached to its premises known as 3510 N. Kedzie Ave..

Said sign structure(s) measures as follows; along N. Kedzie Avenue:

One (1) at twenty-two (22) feet in length, two (2) feet in height and ten point five (10.5) feet above grade level.

The location of said privilege shall be as shown on prints kept on file with the Department of Business Affairs and Consumer Protection and the Office of the City Clerk.

Said privilege shall be constructed in accordance with plans and specifications approved by the Department of Transportation (Division of Project Development) and Zoning Department - Signs.

This grant of privilege in the public way shall be subject to the provisions of Section 10-28-015 and all other required provisions of the Municipal Code of Chicago.

The grantee shall pay to the City of Chicago as compensation for the privilege #1113148 herein granted the sum of three hundred (\$300.00) per annum in advance.

A 25% penalty will be added for payments received after due date.

The permit holder agrees to hold the City of Chicago harmless for any damage, relocation or replacement costs associated with damage, relocation or removal of private property caused by the City performing work in the public way.

Authority herein given and granted for a period of five (5) years from and after 01/13/2014.

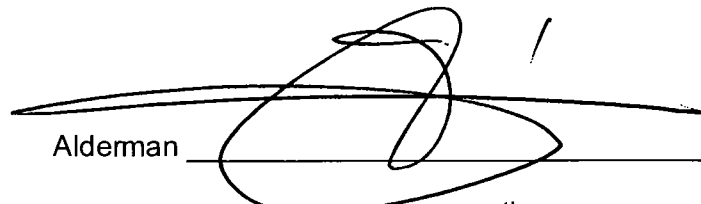
Alderman _____
Reynaldo Colon 35th Ward

22'0"

CURRENCY EXCHANGE

2'0"

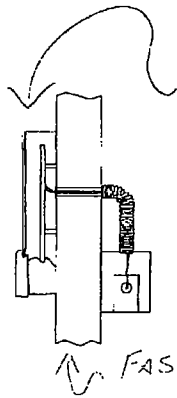

24" LETTERS
SIGN LETTER ENCROACHMENT
5" OVER THE PUBLIC ROW.

FASCIA

| | |
|-------------------------------|----------------------|
| BEST NEON SIGN CO. | |
| SCALE | NO SCALE SK. NO. 001 |
| CUSTOMER | KEDZIE ELECTRIC CO. |
| JOB ADDRESS | 3510 N. KEDZIE |
| CITY CHICAGO | STATE IL. |
| ARTIST JC | DATE |
| SALES APPROVED | DATE |
| CUSTOMER APPROVAL: | |

By signing the approval box on this sketch, I understand that I am accepting all aspects of this drawing. This includes artwork, specifications, dimensions, spelling and any other representations herein. I also understand that color reproductions on this sketch are approximate, and may not match manufactured product exactly.



05/28/2014

Alderman **Reynaldo Colon**
Ward # **35**
City of Chicago
City Hall, Room **203**
121 North LaSalle Street
Chicago, Illinois 60602

Re: An ordinance to use and maintain a portion of the public right-of-way for **one (1) sign(s)** for **KEDZIE ELSTON C.E.,INC**, adjacent to the premises known as **3510 N. Kedzie Ave.**.

Dear Alderman **Reynaldo Colon**:

The applicant referenced above has requested the use of the public right-of-way for a **sign(s)**. An ordinance has been prepared by the Department of Business Affairs and Consumer Protection – Small Business Center - Public Way Use Unit for presentation to the City Council. Because this request was made for properties located in your ward, as approved by you as per the attached, I respectfully request that you introduce the attached ordinance at the next City Council meeting.

If you have any questions regarding this ordinance, please contact Anthony Bertuca at (312) 744-5506.

Department of Business Affairs and Consumer Protection



City of Chicago



O2014-4615

Office of the City Clerk

Document Tracking Sheet

| | |
|---------------------------------|--|
| Meeting Date: | 5/28/2014 |
| Sponsor(s): | Colón (35) |
| Type: | Ordinance |
| Title: | Grant(s) of privilege in public way for L' Patron - 2815 W Diversey Ave |
| Committee(s) Assignment: | Committee on Transportation and Public Way |

ORDINANCE
L' PATRON
Acct. No. 376626 - 2
Permit No. 1112737

Be It Ordained by the City Council of the City of Chicago:

SECTION 1. Permission and authority are hereby given and granted to L' PATRON, upon the terms and subject to the conditions of this ordinance to maintain and use, as now constructed, one (1) Wind Screen(s) on the public right-of-way adjacent to its premises known as 2815 W. Diversey Ave..

Said Wind Screen(s) at W Diversey Ave measure(s):

One (1) at five point three three (5.33) feet in length, and one (1) foot in width for a total of five point three three (5.33) square feet.

The location of said privilege shall be as shown on prints kept on file with the Department of Business Affairs and Consumer Protection and the Office of the City Clerk.

Said privilege shall be constructed in accordance with plans and specifications approved by the Department of Transportation (Division of Project Development).

This grant of privilege in the public way shall be subject to the provisions of Section 10-28-015 and all other required provisions of the Municipal Code of Chicago.

The grantee shall pay to the City of Chicago as compensation for the privilege #1112737 herein granted the sum of four hundred (\$400.00) per annum in advance.

A 25% penalty will be added for payments received after due date.

The permit holder agrees to hold the City of Chicago harmless for any damage, relocation or replacement costs associated with damage, relocation or removal of private property caused by the City performing work in the public way.

Authority herein given and granted for a period of five (5) years from and after Date of Passage.

Alderman _____
Reynaldo Colon 35th Ward

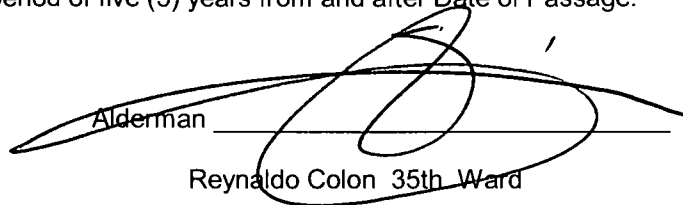

Awnings Express

Office: (773) 579-1437
8028 S. Western Ave.
Chicago, IL 60620

L' PATRON

2815 W. Diversey
Chicago, IL 60647

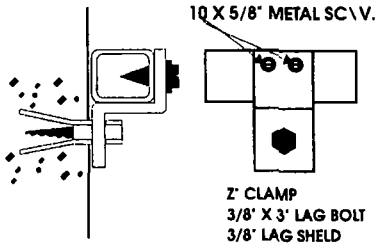

FRAME TO WALL ANCHOR DETAIL

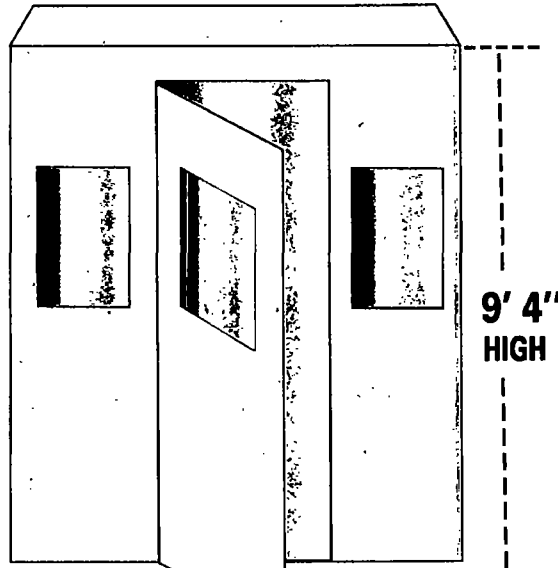

Frame Construction

Sunbrella
FABRIC COVER
LACED ON - TYP.
(100% PMS 527 COLOR)

3/4" SQ. GALV. STL.
TUBING 16 GA. - TYP.
(TOP, BACK & SIDES)

5/8" RND. GALV. STL.
TUBING - TYP.
(RAFTERS)

1/2" RND. GALV. STL.
TUBING - TYP.
(LACING ROD)

1" SQ. GALV. STEEL
TUBING 16GA - TYP.
(BOTTOM PERIMETER)

FRAME STRUCTURE WITH HOLDS
WINDS AT 90mil, per hr.

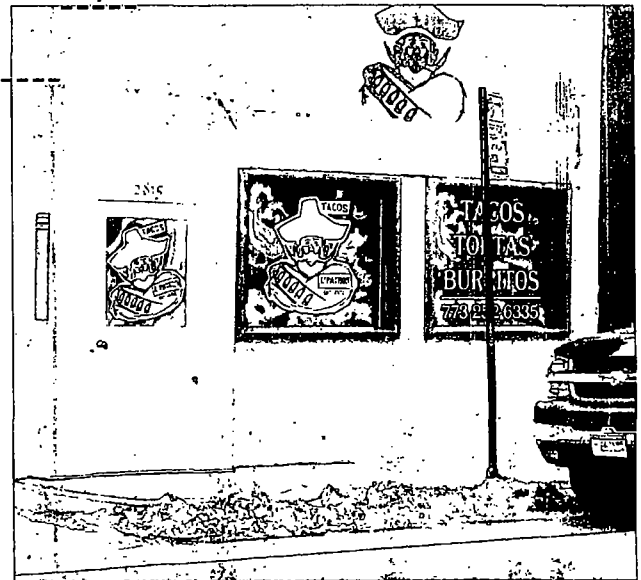



05/28/2014

Alderman **Reynaldo Colon**
Ward # **35**
City of Chicago
City Hall, Room **203**
121 North LaSalle Street
Chicago, Illinois 60602

Re: An ordinance to use and maintain a portion of the public right-of-way for **one (1) wind screen(s)** for **L' PATRON**, adjacent to the premises known as **2815 W. Diversey Ave.**.

Dear Alderman **Reynaldo Colon**:

The applicant referenced above has requested the use of the public right-of-way for a **wind screen(s)**. An ordinance has been prepared by the Department of Business Affairs and Consumer Protection – Small Business Center - Public Way Use Unit for presentation to the City Council. Because this request was made for properties located in your ward, as approved by you as per the attached, I respectfully request that you introduce the attached ordinance at the next City Council meeting.

If you have any questions regarding this ordinance, please contact Anthony Bertuca at (312) 744-5506.

Department of Business Affairs and Consumer Protection



City of Chicago



O2014-4618

Office of the City Clerk

Document Tracking Sheet

| | |
|---------------------------------|--|
| Meeting Date: | 5/28/2014 |
| Sponsor(s): | Colón (35) |
| Type: | Ordinance |
| Title: | Grant(s) of privilege in public way for L' Patron - 2817 W Diversey Ave |
| Committee(s) Assignment: | Committee on Transportation and Public Way |

ORDINANCE
L' PATRON
Acct. No. 376626 - 2
Permit No. 1112738

Be It Ordained by the City Council of the City of Chicago:

SECTION 1. Permission and authority are hereby given and granted to L' PATRON, upon the terms and subject to the conditions of this ordinance to maintain and use, as now constructed, one (1) Wind Screen(s) on the public right-of-way adjacent to its premises known as 2817 W. Diversey Ave..

Said Wind Screen(s) at W Diversey Ave measure(s):

One (1) at seven (7) feet in length, and one (1) foot in width for a total of seven (7) square feet.

The location of said privilege shall be as shown on prints kept on file with the Department of Business Affairs and Consumer Protection and the Office of the City Clerk.

Said privilege shall be constructed in accordance with plans and specifications approved by the Department of Transportation (Division of Project Development).

This grant of privilege in the public way shall be subject to the provisions of Section 10-28-015 and all other required provisions of the Municipal Code of Chicago.

The grantee shall pay to the City of Chicago as compensation for the privilege #1112738 herein granted the sum of four hundred (\$400.00) per annum in advance.

A 25% penalty will be added for payments received after due date.

The permit holder agrees to hold the City of Chicago harmless for any damage, relocation or replacement costs associated with damage, relocation or removal of private property caused by the City performing work in the public way.

Authority herein given and granted for a period of five (5) years from and after Date of Passage.

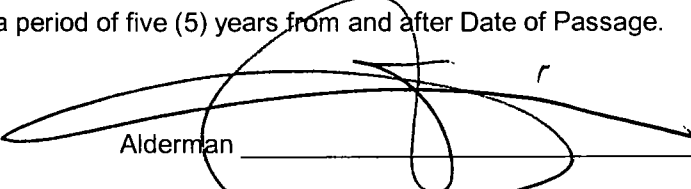
Alderman _____
Reynaldo Colon 35th Ward

L' PATRON
2817 W. DIVERSEY
CHICAGO ,IL 60647

Awwmings
Express

Office: (773)579-1437
8028 S. Western Ave.
Chicago , IL 60620

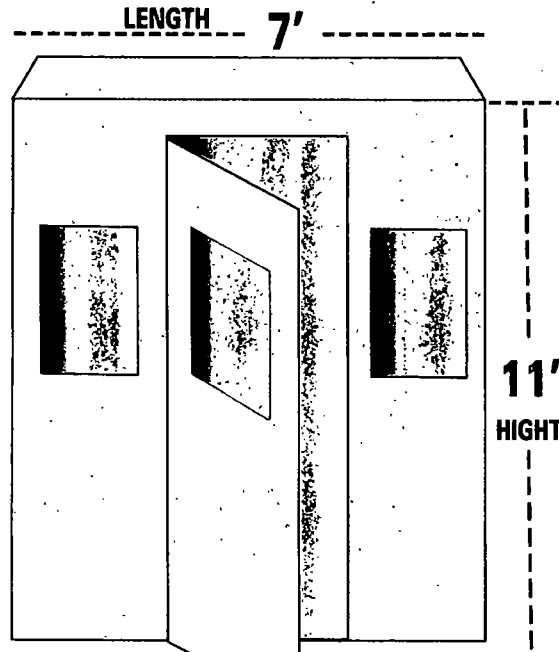

Frame Construction

Sunbrella
FABRIC COVER
LACED ON - TYP
(100% PMS 527 COLOR)

3/4" SQ. GALV. STL.
TUBING 16 GA. - TYP.
(TOP, BACK & SIDES)

5/8" RND. GALV. STL.
TUBING - TYP.
(RAFTERS)

V2" RND. GALV. STL.
TUBING - TYP.
(LACING ROD)

1" SQ. GALV. STEEL
TUBING 16GA - TYP.
(BOTTOM PERIMETER)

FRAME STRUCTURE WITH HOLDS
WINDS AT 90mil, per hr.

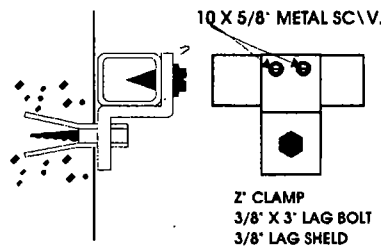
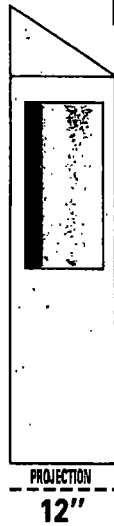

FRAME TO WALL ANCHOR DETAIL

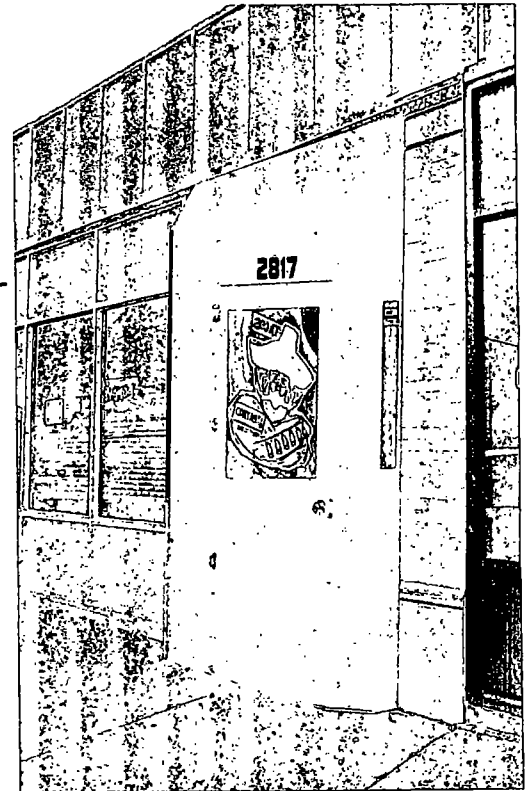



05/28/2014

Alderman **Reynaldo Colon**
Ward # **35**
City of Chicago
City Hall, Room **203**
121 North LaSalle Street
Chicago, Illinois 60602

Re: An ordinance to use and maintain a portion of the public right-of-way for **one (1) wind screen(s)** for **L' PATRON**, adjacent to the premises known as **2817 W. Diversey Ave.**.

Dear Alderman **Reynaldo Colon**:

The applicant referenced above has requested the use of the public right-of-way for a **wind screen(s)**. An ordinance has been prepared by the Department of Business Affairs and Consumer Protection -- Small Business Center - Public Way Use Unit for presentation to the City Council. Because this request was made for properties located in your ward, as approved by you as per the attached, I respectfully request that you introduce the attached ordinance at the next City Council meeting.

If you have any questions regarding this ordinance, please contact Anthony Bertuca at (312) 744-5506.

Department of Business Affairs and Consumer Protection



City of Chicago



O2014-4622

Office of the City Clerk

Document Tracking Sheet

| | |
|---------------------------------|---|
| Meeting Date: | 5/28/2014 |
| Sponsor(s): | Mitts (37) |
| Type: | Ordinance |
| Title: | Grant(s) of privilege in public way for My Wireless Store 1021, Inc. |
| Committee(s) Assignment: | Committee on Transportation and Public Way |

ORDINANCE
MY WIRELESS STORE 1021 INC
Acct. No. 384926 - 2
Permit No. 1110845

Be It Ordained by the City Council of the City of Chicago:

SECTION 1. Permission and authority are hereby given and granted to MY WIRELESS STORE 1021 INC, upon the terms and subject to the conditions of this ordinance to maintain and use one (1) sign(s) projecting over the public right-of-way attached to its premises known as 4751 W. North Ave..

Said sign structure(s) measures as follows; along W. North Avenue:
One (1) at twelve (12) feet in length, two point five (2.5) feet in height and ten (10) feet above grade level.

The location of said privilege shall be as shown on prints kept on file with the Department of Business Affairs and Consumer Protection and the Office of the City Clerk.

Said privilege shall be constructed in accordance with plans and specifications approved by the Department of Transportation (Division of Project Development) and Zoning Department - Signs.

This grant of privilege in the public way shall be subject to the provisions of Section 10-28-015 and all other required provisions of the Municipal Code of Chicago.

The grantee shall pay to the City of Chicago as compensation for the privilege #1110845 herein granted the sum of three hundred (\$300.00) per annum in advance.

A 25% penalty will be added for payments received after due date.

The permit holder agrees to hold the City of Chicago harmless for any damage, relocation or replacement costs associated with damage, relocation or removal of private property caused by the City performing work in the public way.

Authority herein given and granted for a period of five (5) years from and after Date of Passage.

Alderman

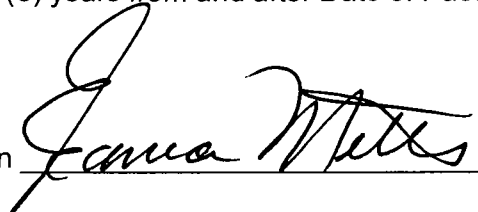

Emma Mitts 37th Ward

Chicago IL - W North Avenue



GENERAL SPECIFICATIONS:

SINGLE FACE ILLUMINATED SIGN CABINET WITH 3/16" THICK WHITE ACRYLIC PLEX FACES WITH APPLIED BLACK #3630-22 AND TANGERINE #3830-64 TRANSLUCENT VINYL. SIGN CABINET CONSTRUCTED OF .125 EXTRUDED ALUMINUM WITH REMOVABLE SIGN FACE RETAINERS. SIGN CABINET ILLUMINATED WITH HIGH OUTPUT DHO FLORESCENT LAMPS AND ELECTRONIC BALLASTS. CLIENT TO SUPPLY ONE (1) 20 AMP 120 VOLT CIRCUIT WITHIN 60" OF SIGN INSTALL AREA.

signage **US**

Phone: 203-440-8419
 Fax: 203-530-2780
 Web: signagous.com

03201-C01



Drawing Date: 11/20/13
 Drawing Number: B103116
 Drawing by: RL

The drawing is the property of Signage US and all rights to its use for reproduction are strictly reserved by Signage US

Signage Approval

- Approved
- Approved As Noted
- Not Approved - revise As Noted



05/28/2014

Alderman **Emma Mitts**
Ward # **37**
City of Chicago
City Hall, Room **300**
121 North LaSalle Street
Chicago, Illinois 60602

Re: An ordinance to use and maintain a portion of the public right-of-way for **one (1) sign(s)** for **MY WIRELESS STORE 1021 INC**, adjacent to the premises known as **4751 W. North Ave.**.

Dear Alderman **Emma Mitts**:

The applicant referenced above has requested the use of the public right-of-way for a **sign(s)**. An ordinance has been prepared by the Department of Business Affairs and Consumer Protection – Small Business Center - Public Way Use Unit for presentation to the City Council. Because this request was made for properties located in your ward, as approved by you as per the attached, I respectfully request that you introduce the attached ordinance at the next City Council meeting.

If you have any questions regarding this ordinance, please contact Anthony Bertuca at (312) 744-5506.

Department of Business Affairs and Consumer Protection



City of Chicago



O2014-4628

Office of the City Clerk

Document Tracking Sheet

| | |
|---------------------------------|--|
| Meeting Date: | 5/28/2014 |
| Sponsor(s): | Laurino (39) |
| Type: | Ordinance |
| Title: | Grant(s) of privilege in public way for A. K. Auto Service, Inc. |
| Committee(s) Assignment: | Committee on Transportation and Public Way |

ORDINANCE
A. K. AUTO SERVICE INC.
Acct. No. 29459 - 1
Permit No. 1113087

Be It Ordained by the City Council of the City of Chicago:

SECTION 1. Permission and authority are hereby given and granted to A. K. AUTO SERVICE INC., upon the terms and subject to the conditions of this ordinance to maintain and use one (1) sign(s) projecting over the public right-of-way attached to its premises known as 4747 N. Pulaski Rd..

Said sign structure(s) measures as follows; along N. PULASKI RD.:
One (1) at six (6) feet in length, one point five (1.5) feet in height and ten (10) feet above grade level.

The location of said privilege shall be as shown on prints kept on file with the Department of Business Affairs and Consumer Protection and the Office of the City Clerk.

Said privilege shall be constructed in accordance with plans and specifications approved by the Department of Transportation (Division of Project Development) and Zoning Department - Signs.

This grant of privilege in the public way shall be subject to the provisions of Section 10-28-015 and all other required provisions of the Municipal Code of Chicago.

The grantee shall pay to the City of Chicago as compensation for the privilege #1113087 herein granted the sum of one hundred (\$100.00) per annum in advance.

A 25% penalty will be added for payments received after due date.

The permit holder agrees to hold the City of Chicago harmless for any damage, relocation or replacement costs associated with damage, relocation or removal of private property caused by the City performing work in the public way.

Authority herein given and granted for a period of five (5) years from and after 05/13/2014.

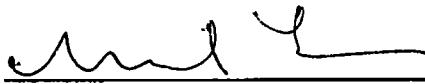
Alderman 
Margaret Laurino 39th Ward

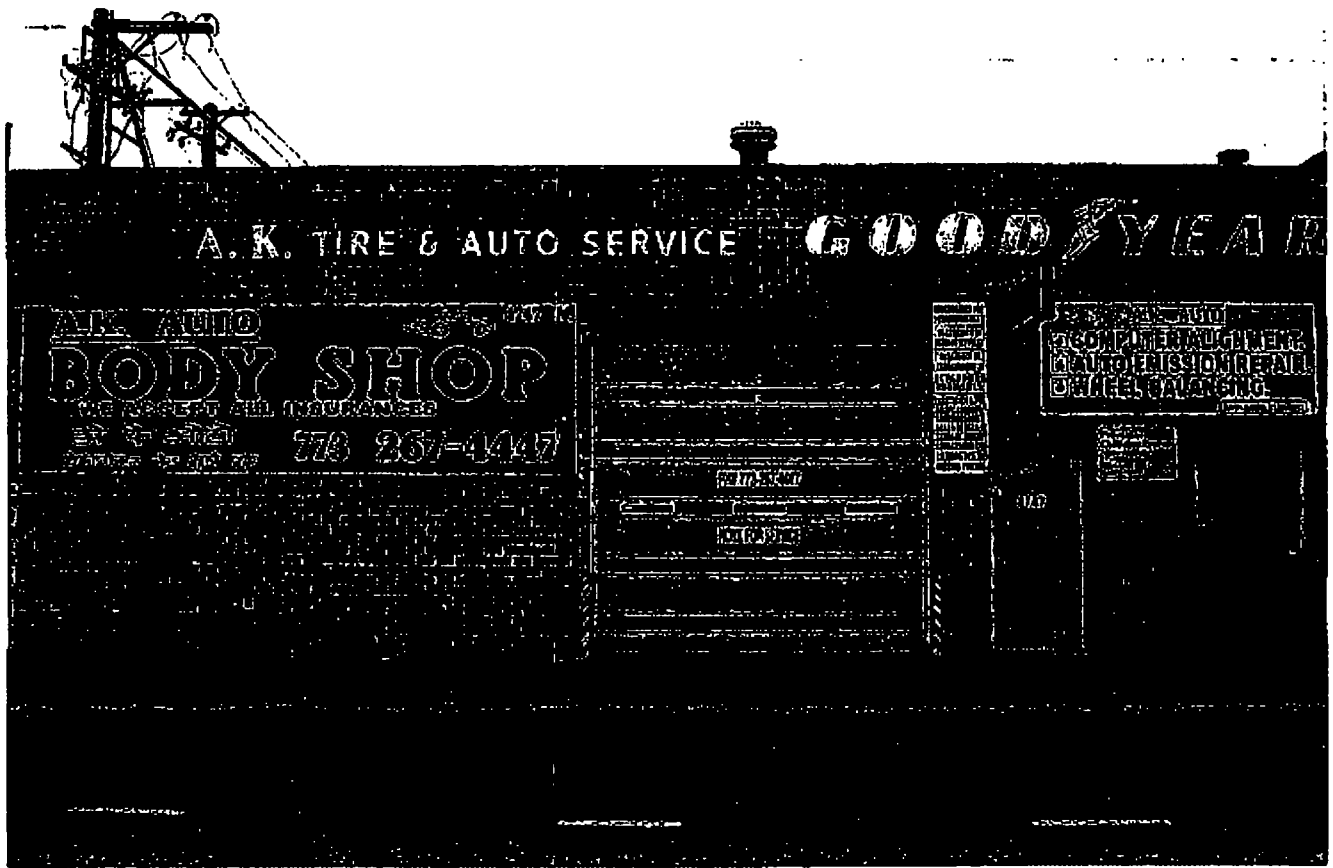

A.K. TIRE & AUTO SERVICE

GOODYEAR

A.K. AUTO
BODY SHOP
WE ACCEPT ALL INSURANCES
EST. 1962
778 267-4447

COMPUTER ALIGNMENT
BRAKE INSPECTION
TIRE BALANCING



City of Chicago



O2014-4634

Office of the City Clerk

Document Tracking Sheet

| | |
|---------------------------------|--|
| Meeting Date: | 5/28/2014 |
| Sponsor(s): | Laurino (39) |
| Type: | Ordinance |
| Title: | Grant(s) of privilege in public way for Pearl Beauty |
| Committee(s) Assignment: | Committee on Transportation and Public Way |

ORDINANCE
PEARL BEAUTY
Acct. No. 349821 - 2
Permit No. 1110269

Be It Ordained by the City Council of the City of Chicago:

SECTION 1. Permission and authority are hereby given and granted to PEARL BEAUTY, upon the terms and subject to the conditions of this ordinance to maintain and use one (1) sign(s) projecting over the public right-of-way attached to its premises known as 6120 N. Pulaski Rd..

Said sign structure(s) measures as follows; along N. Pulaski Road:
One (1) at fifteen (15) feet in length, one point five (1.5) feet in height and nine (9) feet above grade level.

The location of said privilege shall be as shown on prints kept on file with the Department of Business Affairs and Consumer Protection and the Office of the City Clerk

Said privilege shall be constructed in accordance with plans and specifications approved by the Department of Transportation (Division of Project Development) and Zoning Department- Signs.

This grant of privilege in the public way shall be subject to the provisions of Section 10-28-015 and all other required provisions of the Municipal Code of Chicago.

The grantee shall pay to the City of Chicago as compensation for the privilege #1110269 herein granted the sum of one hundred (\$100.00) per annum in advance.

A 25% penalty will be added for payments received after due date

The permit holder agrees to hold the City of Chicago harmless for any damage, relocation or replacement costs associated with damage, relocation or removal of private property caused by the City performing work in the public way.

Authority herein given and granted for a period of five (5) years from and after Date of Passage.

Alderman 

Margaret Laurino 39th Ward



APPLICATION TO USE THE PUBLIC RIGHT OF WAY

EXAMPLE OF SIGN DRAWING

PROPERTY LOCATION: 6120 N. Polaski

ORGANIZATION(S) NAME: LMD INC.

HEIGHT OF STRUCTURE

18"



DEPTH OF STRUCTURE

12"

LENGTH OF STRUCTURE

180"

TOTAL DEPTH OVER THE PUBLIC WAY

12"

HEIGHT ABOVE GRADE (SIDEWALK)

9'

SIDEWALK





City of Chicago



O2014-4772

Office of the City Clerk

Document Tracking Sheet

| | |
|---------------------------------|--|
| Meeting Date: | 5/28/2014 |
| Sponsor(s): | O'Connor (40) |
| Type: | Ordinance |
| Title: | Grant(s) of privilege in public way for New Chicago Restaurant |
| Committee(s) Assignment: | Committee on Transportation and Public Way |

ORDINANCE
NEW CHICAGO RESTAURANT
Acct. No. 304635 - 1
Permit No. 1113123

Be It Ordained by the City Council of the City of Chicago:

SECTION 1. Permission and authority are hereby given and granted to NEW CHICAGO RESTAURANT, upon the terms and subject to the conditions of this ordinance to maintain and use one (1) sign(s) projecting over the public right-of-way attached to its premises known as 5100 N. Western Ave..

Said sign structure(s) measures as follows; along N. Western Avenue:
One (1) at two point one seven (2.17) feet in length, nine (9) feet in height and ten (10) feet above grade level.

The location of said privilege shall be as shown on prints kept on file with the Department of Business Affairs and Consumer Protection and the Office of the City Clerk.

Said privilege shall be constructed in accordance with plans and specifications approved by the Department of Transportation (Division of Project Development) and Zoning Department - Signs.

This grant of privilege in the public way shall be subject to the provisions of Section 10-28-015 and all other required provisions of the Municipal Code of Chicago.

The grantee shall pay to the City of Chicago as compensation for the privilege #1113123 herein granted the sum of one hundred (\$100.00) per annum in advance.

A 25% penalty will be added for payments received after due date.

The permit holder agrees to hold the City of Chicago harmless for any damage, relocation or replacement costs associated with damage, relocation or removal of private property caused by the City performing work in the public way.

Authority herein given and granted for a period of five (5) years from and after 05/13/2014.

Alderman

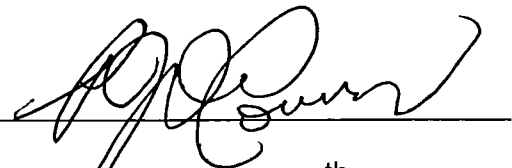
A handwritten signature in black ink, appearing to read "Patrick O'Connor", written over a horizontal line.

Patrick O'Connor 40th Ward

(JPEG Image, 640 x 480 pixels)

http://web.mail.comcast.net/service/home/~/?auth=co&loc=en_US&i...

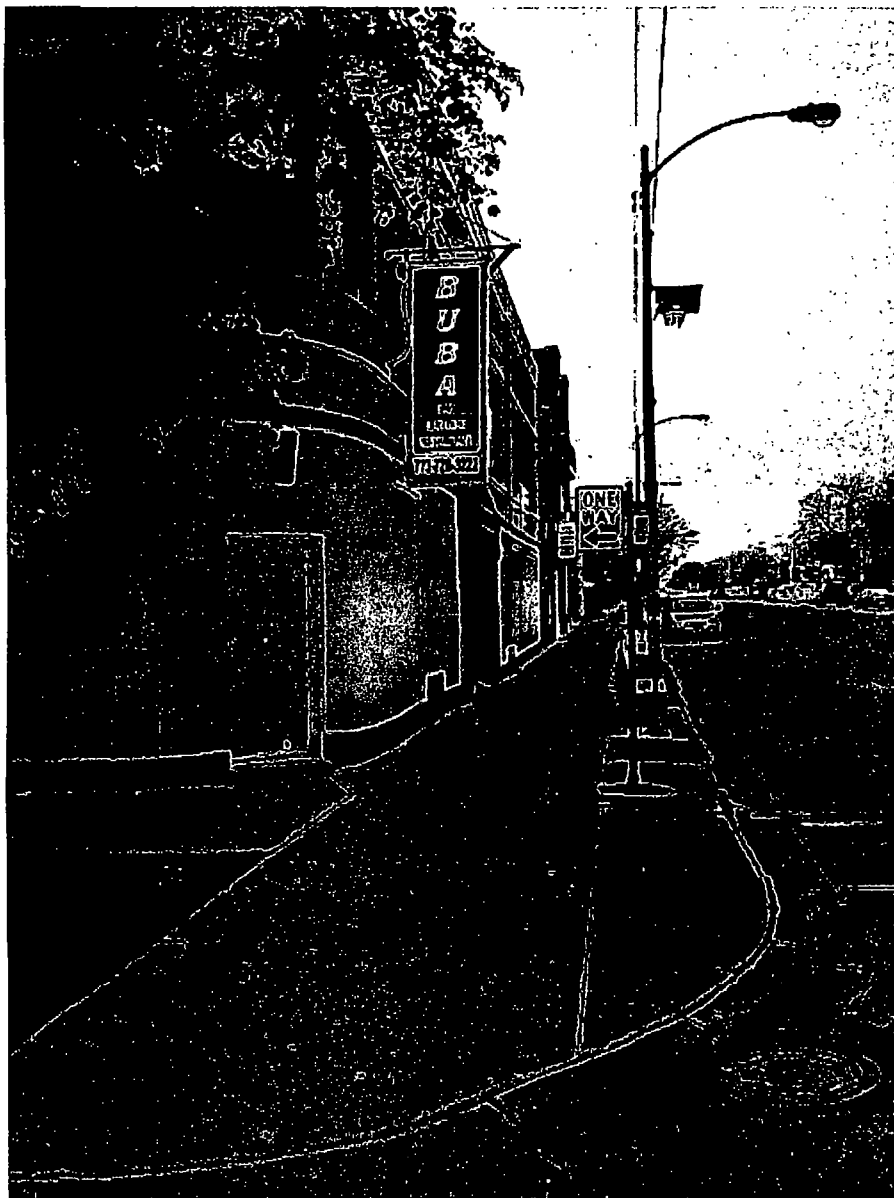



05/28/2014

Alderman **Patrick O'Connor**
Ward # **40**
City of Chicago
City Hall, Room **305**
121 North LaSalle Street
Chicago, Illinois 60602

Re: An ordinance to use and maintain a portion of the public right-of-way for **one (1) sign(s)** for **NEW CHICAGO RESTAURANT**, adjacent to the premises known as **5100 N. Western Ave.**

Dear Alderman **Patrick O'Connor**:

The applicant referenced above has requested the use of the public right-of-way for a **sign(s)**. An ordinance has been prepared by the Department of Business Affairs and Consumer Protection – Small Business Center - Public Way Use Unit for presentation to the City Council. Because this request was made for properties located in your ward, as approved by you as per the attached, I respectfully request that you introduce the attached ordinance at the next City Council meeting.

If you have any questions regarding this ordinance, please contact Anthony Bertuca at (312) 744-5506.

Department of Business Affairs and Consumer Protection



City of Chicago



O2014-4774

Office of the City Clerk

Document Tracking Sheet

| | |
|---------------------------------|--|
| Meeting Date: | 5/28/2014 |
| Sponsor(s): | O'Connor (40) |
| Type: | Ordinance |
| Title: | Grant(s) of privilege in public way for Scooterworks USA |
| Committee(s) Assignment: | Committee on Transportation and Public Way |

ORDINANCE
SCOOTERWORKS USA, INC.
Acct. No. 32731 - 3
Permit No. 1113091

Be It Ordained by the City Council of the City of Chicago:

SECTION 1. Permission and authority are hereby given and granted to SCOOTERWORKS USA, INC., upon the terms and subject to the conditions of this ordinance to maintain and use one (1) sign(s) projecting over the public right-of-way attached to its premises known as 5410 N. Damen Ave..

Said sign structure(s) measures as follows; along N DAMEN AVE:
One (1) at six (6) feet in length, three (3) feet in height and ten (10) feet above grade level.

The location of said privilege shall be as shown on prints kept on file with the Department of Business Affairs and Consumer Protection and the Office of the City Clerk.

Said privilege shall be constructed in accordance with plans and specifications approved by the Department of Transportation (Division of Project Development) and Zoning Department - Signs.

This grant of privilege in the public way shall be subject to the provisions of Section 10-28-015 and all other required provisions of the Municipal Code of Chicago.

The grantee shall pay to the City of Chicago as compensation for the privilege #1113091 herein granted the sum of one hundred (\$100.00) per annum in advance.

A 25% penalty will be added for payments received after due date.

The permit holder agrees to hold the City of Chicago harmless for any damage, relocation or replacement costs associated with damage, relocation or removal of private property caused by the City performing work in the public way.

Authority herein given and granted for a period of five (5) years from and after 04/22/2014.

Alderman

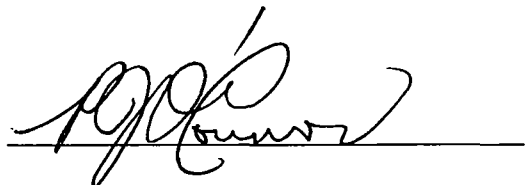
A handwritten signature in black ink, appearing to read 'Patrick O'Connor', written over a horizontal line.

Patrick O'Connor 40th Ward





05/28/2014

Alderman **Patrick O'Connor**
Ward # **40**
City of Chicago
City Hall, Room **305**
121 North LaSalle Street
Chicago, Illinois 60602

Re: An ordinance to use and maintain a portion of the public right-of-way for **one (1) sign(s)** for **SCOOTERWORKS USA, INC.**, adjacent to the premises known as **5410 N. Damen Ave.**.

Dear Alderman **Patrick O'Connor**:

The applicant referenced above has requested the use of the public right-of-way for a **sign(s)**. An ordinance has been prepared by the Department of Business Affairs and Consumer Protection – Small Business Center - Public Way Use Unit for presentation to the City Council. Because this request was made for properties located in your ward, as approved by you as per the attached, I respectfully request that you introduce the attached ordinance at the next City Council meeting.

If you have any questions regarding this ordinance, please contact Anthony Bertuca at (312) 744-5506.

Department of Business Affairs and Consumer Protection



City of Chicago



O2014-4776

Office of the City Clerk

Document Tracking Sheet

| | |
|---------------------------------|--|
| Meeting Date: | 5/28/2014 |
| Sponsor(s): | O'Connor (40) |
| Type: | Ordinance |
| Title: | Grant(s) of privilege in public way for Superior Super Auto Wash |
| Committee(s) Assignment: | Committee on Transportation and Public Way |

ORDINANCE
SUPERIOR SUPER AUTO WASH
Acct. No. 85389 - 2
Permit No. 1113041

Be It Ordained by the City Council of the City of Chicago:

SECTION 1. Permission and authority are hereby given and granted to SUPERIOR SUPER AUTO WASH, upon the terms and subject to the conditions of this ordinance to maintain and use two (2) sign(s) projecting over the public right-of-way attached to its premises known as 5450 N. Damen Ave..

Said sign structure(s) measures as follows; along 5440 N. Damen Avenue:
One (1) at eight (8) feet in length, five (5) feet in height and twelve (12) feet above grade level.

Said sign structure(s) measures as follows; along 5430 N. Damen Avenue:
One (1) at eight (8) feet in length, seven (7) feet in height and thirteen (13) feet above grade level.

The location of said privilege shall be as shown on prints kept on file with the Department of Business Affairs and Consumer Protection and the Office of the City Clerk.

Said privilege shall be constructed in accordance with plans and specifications approved by the Department of Transportation (Division of Project Development) and Zoning Department - Signs.

This grant of privilege in the public way shall be subject to the provisions of Section 10-28-015 and all other required provisions of the Municipal Code of Chicago.

The grantee shall pay to the City of Chicago as compensation for the privilege #1113041 herein granted the sum of six hundred (\$600.00) per annum in advance.

A 25% penalty will be added for payments received after due date.

The permit holder agrees to hold the City of Chicago harmless for any damage, relocation or replacement costs associated with damage, relocation or removal of private property caused by the City performing work in the public way.

Authority herein given and granted for a period of five (5) years from and after 04/22/2014.

Alderman  _____
Patrick O'Connor 40th Ward

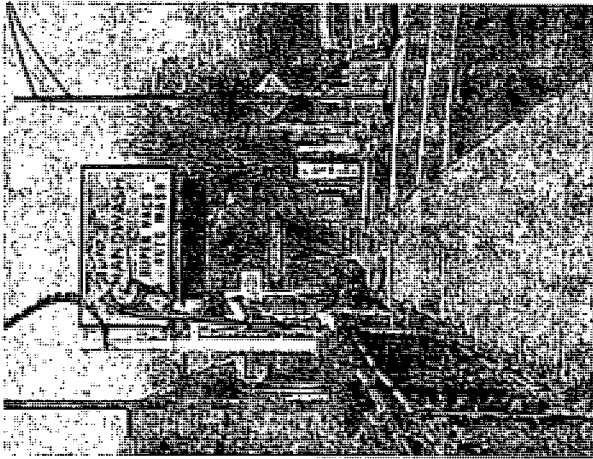

5440 N. DAMEN.



05/28/2014

Alderman **Patrick O'Connor**
Ward # **40**
City of Chicago
City Hall, Room **305**
121 North LaSalle Street
Chicago, Illinois 60602

Re: An ordinance to use and maintain a portion of the public right-of-way for **two (2) sign(s)** for
SUPERIOR SUPER AUTO WASH, adjacent to the premises known as **5450 N. Damen Ave.**.

Dear Alderman **Patrick O'Connor**:

The applicant referenced above has requested the use of the public right-of-way for a **sign(s)**. An ordinance has been prepared by the Department of Business Affairs and Consumer Protection – Small Business Center - Public Way Use Unit for presentation to the City Council. Because this request was made for properties located in your ward, as approved by you as per the attached, I respectfully request that you introduce the attached ordinance at the next City Council meeting.

If you have any questions regarding this ordinance, please contact Anthony Bertuca at (312) 744-5506.

Department of Business Affairs and Consumer Protection



City of Chicago



O2014-4778

Office of the City Clerk Document Tracking Sheet

| | |
|---------------------------------|---|
| Meeting Date: | 5/28/2014 |
| Sponsor(s): | O'Connor (41) |
| Type: | Ordinance |
| Title: | Grant(s) of privilege in public way for Lehigh Dental Care Ltd. |
| Committee(s) Assignment: | Committee on Transportation and Public Way |

ORDINANCE
LEHIGH DENTAL CARE LTD
Acct. No. 75493 - 1
Permit No. 1112954

Be It Ordained by the City Council of the City of Chicago:

SECTION 1. Permission and authority are hereby given and granted to LEHIGH DENTAL CARE LTD, upon the terms and subject to the conditions of this ordinance to maintain and use one (1) sign(s) projecting over the public right-of-way attached to its premises known as 6420 N. Lehigh Ave..

Said sign structure(s) measures as follows; along N. Lehigh Avenue:
One (1) at eight (8) feet in length, six (6) feet in height and eleven (11) feet above grade level.

The location of said privilege shall be as shown on prints kept on file with the Department of Business Affairs and Consumer Protection and the Office of the City Clerk.

Said privilege shall be constructed in accordance with plans and specifications approved by the Department of Transportation (Division of Project Development) and Zoning Department - Signs.

This grant of privilege in the public way shall be subject to the provisions of Section 10-28-015 and all other required provisions of the Municipal Code of Chicago.

The grantee shall pay to the City of Chicago as compensation for the privilege #1112954 herein granted the sum of three hundred (\$300.00) per annum in advance.

A 25% penalty will be added for payments received after due date.

The permit holder agrees to hold the City of Chicago harmless for any damage, relocation or replacement costs associated with damage, relocation or removal of private property caused by the City performing work in the public way.

Authority herein given and granted for a period of five (5) years from and after 05/13/2014.

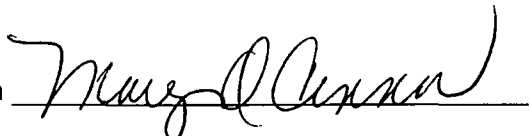
Alderman 
Mary O'Connor 41st Ward

2/2014

20140422_160210.jpg





05/28/2014

Alderman **Mary O'Connor**
Ward # **41**
City of Chicago
City Hall, Room **203**
121 North LaSalle Street
Chicago, Illinois 60602

Re: An ordinance to use and maintain a portion of the public right-of-way for **one (1) sign(s)** for
LEHIGH DENTAL CARE LTD, adjacent to the premises known as **6420 N. Lehigh Ave.**.

Dear Alderman **Mary O'Connor**:

The applicant referenced above has requested the use of the public right-of-way for a **sign(s)**. An ordinance has been prepared by the Department of Business Affairs and Consumer Protection – Small Business Center - Public Way Use Unit for presentation to the City Council. Because this request was made for properties located in your ward, as approved by you as per the attached, I respectfully request that you introduce the attached ordinance at the next City Council meeting.

If you have any questions regarding this ordinance, please contact Anthony Bertuca at (312) 744-5506.

Department of Business Affairs and Consumer Protection



City of Chicago

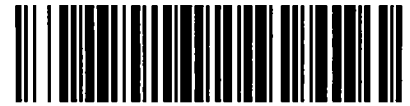

O2014-4781

Office of the City Clerk

Document Tracking Sheet

| | |
|---------------------------------|---|
| Meeting Date: | 5/28/2014 |
| Sponsor(s): | O'Connor (41) |
| Type: | Ordinance |
| Title: | Grant(s) of privilege in public way for Tricoci University of Beauty Culture LLC |
| Committee(s) Assignment: | Committee on Transportation and Public Way |

ORDINANCE
TRICOCI UNIVERSITY OF BEAUTY CULTURE, LLC
Acct. No. 285309 - 1
Permit No. 1112932

Be It Ordained by the City Council of the City of Chicago:

SECTION 1. Permission and authority are hereby given and granted to TRICOCI UNIVERSITY OF BEAUTY CULTURE, LLC, upon the terms and subject to the conditions of this ordinance to maintain and use one (1) sign(s) projecting over the public right-of-way attached to its premises known as 5321 N. Harlem Ave..

Said sign structure(s) measures as follows; along N. HARLEM:
One (1) at six (6) feet in length, four point one seven (4.17) feet in height and nine point two five (9.25) feet above grade level.

The location of said privilege shall be as shown on prints kept on file with the Department of Business Affairs and Consumer Protection and the Office of the City Clerk.

Said privilege shall be constructed in accordance with plans and specifications approved by the Department of Transportation (Division of Project Development) and Zoning Department - Signs.

This grant of privilege in the public way shall be subject to the provisions of Section 10-28-015 and all other required provisions of the Municipal Code of Chicago.

The grantee shall pay to the City of Chicago as compensation for the privilege #1112932 herein granted the sum of three hundred (\$300.00) per annum in advance.

A 25% penalty will be added for payments received after due date.

The permit holder agrees to hold the City of Chicago harmless for any damage, relocation or replacement costs associated with damage, relocation or removal of private property caused by the City performing work in the public way.

Authority herein given and granted for a period of five (5) years from and after 04/22/2014.

Alderman 

Mary O'Connor 41st Ward

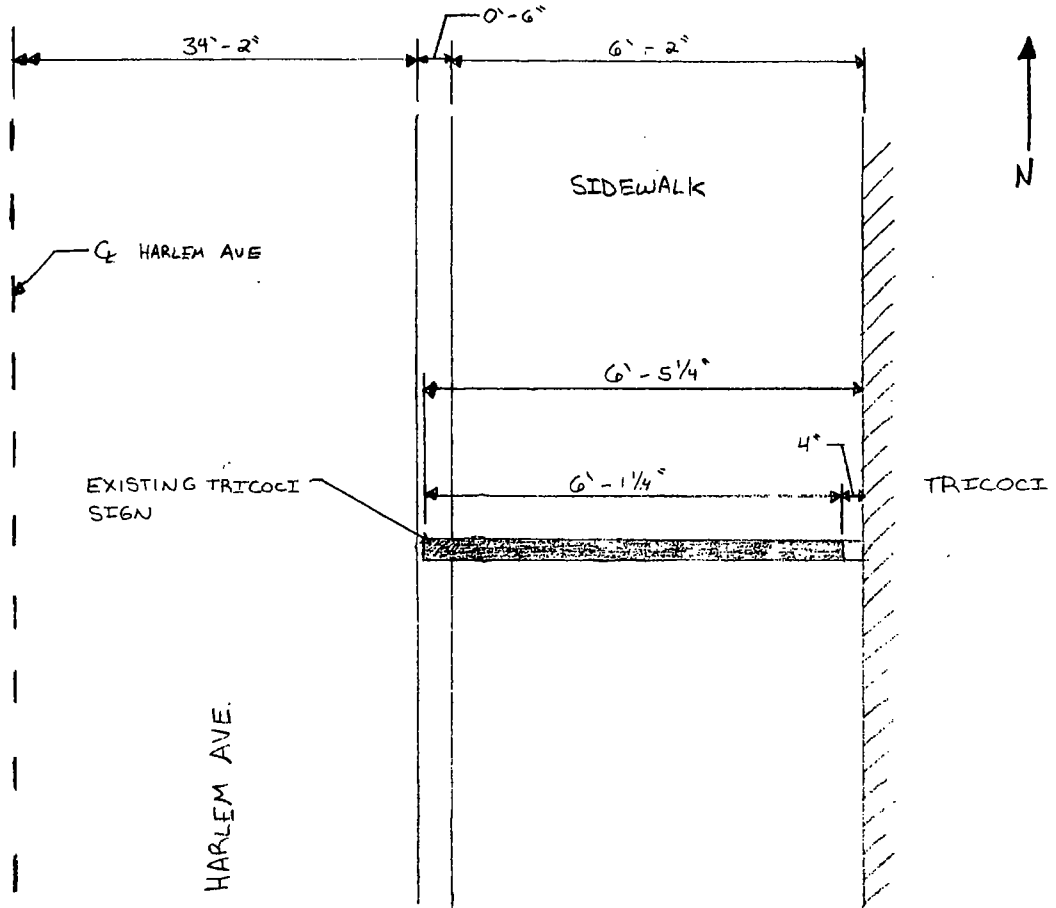

TRICOCI SIGN SITE PLAN
SCALE: 1" = 2'-0"



05/28/2014

Alderman **Mary O'Connor**
Ward # **41**
City of Chicago
City Hall, Room **203**
121 North LaSalle Street
Chicago, Illinois 60602

Re: An ordinance to use and maintain a portion of the public right-of-way for **one (1) sign(s)** for
TRICOCI UNIVERSITY OF BEAUTY CULTURE, LLC, adjacent to the premises known as
5321 N. Harlem Ave..

Dear Alderman **Mary O'Connor**:

The applicant referenced above has requested the use of the public right-of-way for a **sign(s)**. An ordinance has been prepared by the Department of Business Affairs and Consumer Protection – Small Business Center - Public Way Use Unit for presentation to the City Council. Because this request was made for properties located in your ward, as approved by you as per the attached, I respectfully request that you introduce the attached ordinance at the next City Council meeting.

If you have any questions regarding this ordinance, please contact Anthony Bertuca at (312) 744-5506.

Department of Business Affairs and Consumer Protection



City of Chicago



O2014-4783

Office of the City Clerk
Document Tracking Sheet

| | |
|---------------------------------|--|
| Meeting Date: | 5/28/2014 |
| Sponsor(s): | Reilly (42) |
| Type: | Ordinance |
| Title: | Grant(s) of privilege in public way for Argo Tea |
| Committee(s) Assignment: | Committee on Transportation and Public Way |

ORDINANCE
ARGO TEA
Acct. No. 290066 - 1
Permit No. 1112867

Be It Ordained by the City Council of the City of Chicago:

SECTION 1. Permission and authority are hereby given and granted to ARGO TEA, upon the terms and subject to the conditions of this ordinance to maintain and use five (5) sign(s) projecting over the public right-of-way attached to its premises known as 819 N. Rush St..

Said sign structure(s) measures as follows; along RUSH ST.:

Two (2) at thirteen point six seven (13.67) feet in length, two point five (2.5) feet in height and ten (10) feet above grade level.

Said sign structure(s) measures as follows; along PEARSON ST.:

Two (2) at thirteen point six seven (13.67) feet in length, two point five (2.5) feet in height and ten (10) feet above grade level.

Said sign structure(s) measures as follows; along RUSH/PEARSON CORNER:

One (1) at three (3) feet in length, ten (10) feet in height and twelve (12) feet above grade level.

The location of said privilege shall be as shown on prints kept on file with the Department of Business Affairs and Consumer Protection and the Office of the City Clerk.

Said privilege shall be constructed in accordance with plans and specifications approved by the Department of Transportation (Division of Project Development) and Zoning Department - Signs.

This grant of privilege in the public way shall be subject to the provisions of Section 10-28-015 and all other required provisions of the Municipal Code of Chicago.

The grantee shall pay to the City of Chicago as compensation for the privilege #1112867 herein granted the sum of one thousand five hundred (\$1,500.00) per annum in advance.

A 25% penalty will be added for payments received after due date.

The permit holder agrees to hold the City of Chicago harmless for any damage, relocation or replacement costs associated with damage, relocation or removal of private property caused by the City performing work in the public way.

Authority herein given and granted for a period of five (5) years from and after 09/10/2013.

Alderman _____

Brendan Reilly 42nd Ward

Handwritten scribbles or marks, possibly initials or a signature, located in the lower-left quadrant of the page.



PEARSON STREET

SIGN 5

SIGN 3

SEWER

SIGN 4

SIGN 2

ARCO
TEA
819 W. RUSH

SIGN 1

RUSH STREET

74423018

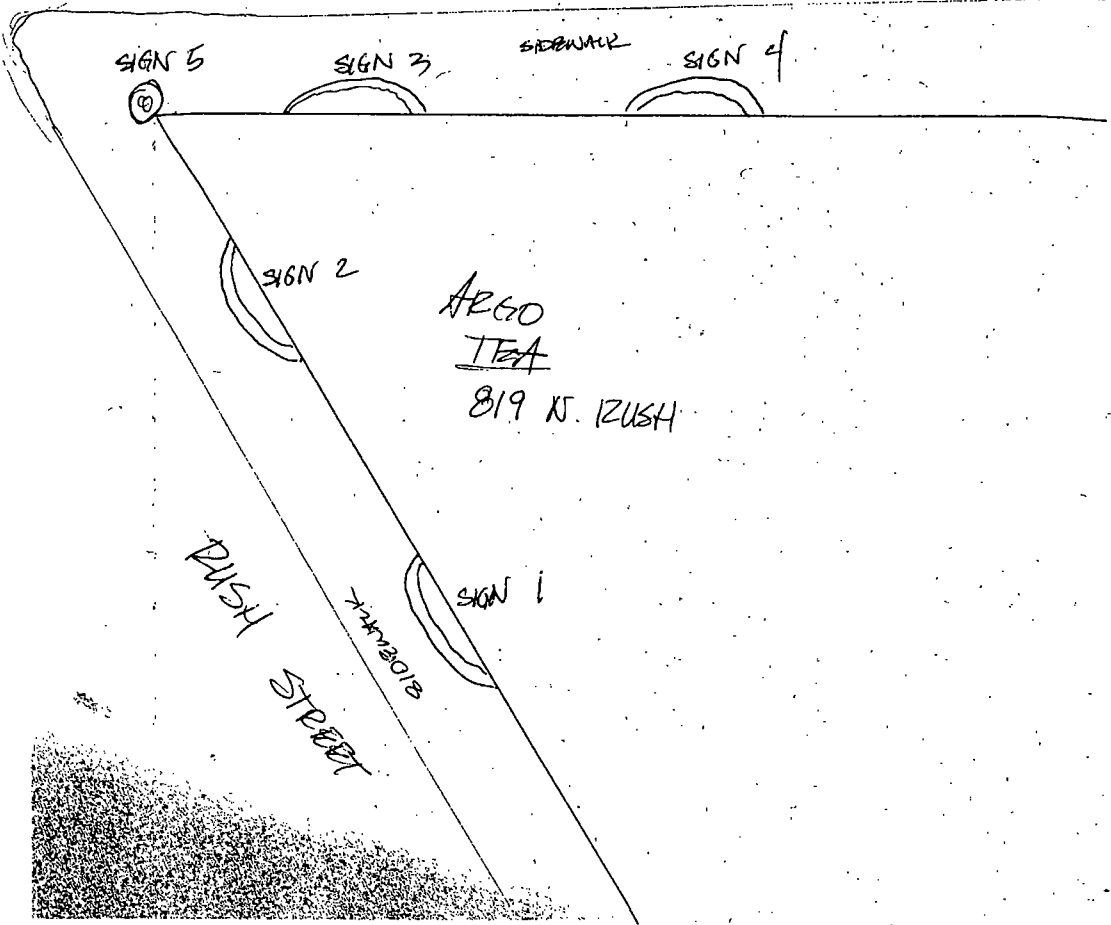



City of Chicago



O2014-4784

Office of the City Clerk

Document Tracking Sheet

| | |
|---------------------------------|--|
| Meeting Date: | 5/28/2014 |
| Sponsor(s): | Reilly (42) |
| Type: | Ordinance |
| Title: | Grant(s) of privilege in public way for Bank of American/LaSalle |
| Committee(s) Assignment: | Committee on Transportation and Public Way |

ORDINANCE
BANK OF AMERICAN/LASALLE
Acct. No. 9118 - 95
Permit No. 1113067

Be It Ordained by the City Council of the City of Chicago:

SECTION 1. Permission and authority are hereby given and granted to BANK OF AMERICAN/LASALLE, upon the terms and subject to the conditions of this ordinance to maintain and use, as now constructed, six (6) Bollard(s) on the public right-of-way adjacent to its premises known as 515 N. La Salle Dr..

Said Bollard(s) at N. La Salle measure(s):

Six (6) at point three three (.33) feet in length, and one (1) foot in width for a total of one point nine eight (1.98) square feet.

The location of said privilege shall be as shown on prints kept on file with the Department of Business Affairs and Consumer Protection and the Office of the City Clerk.

Said privilege shall be constructed in accordance with plans and specifications approved by the Department of Planning and Development and Department of Transportation (Division of Project Development).

This grant of privilege in the public way shall be subject to the provisions of Section 10-28-015 and all other required provisions of the Municipal Code of Chicago.

The grantee shall pay to the City of Chicago as compensation for the privilege #1113067 herein granted the sum of four hundred fifty (\$450.00) per annum in advance.

A 25% penalty will be added for payments received after due date.

The permit holder agrees to hold the City of Chicago harmless for any damage, relocation or replacement costs associated with damage, relocation or removal of private property caused by the City performing work in the public way.

Authority herein given and granted for a period of five (5) years from and after 01/13/2014.

Alderman _____

Brendan Reilly 42nd Ward

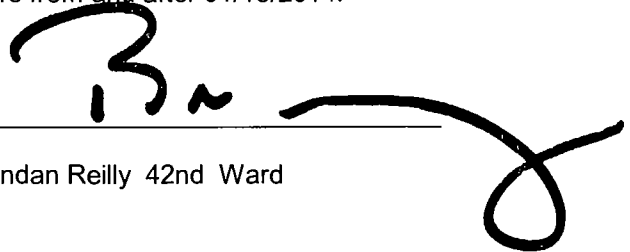
A large, stylized handwritten signature in black ink, appearing to be 'B. Reilly', written over a horizontal line. The signature is fluid and cursive, with a large loop at the end.

Handwritten scribbles or marks, possibly a signature or initials, located in the lower-left quadrant of the page.

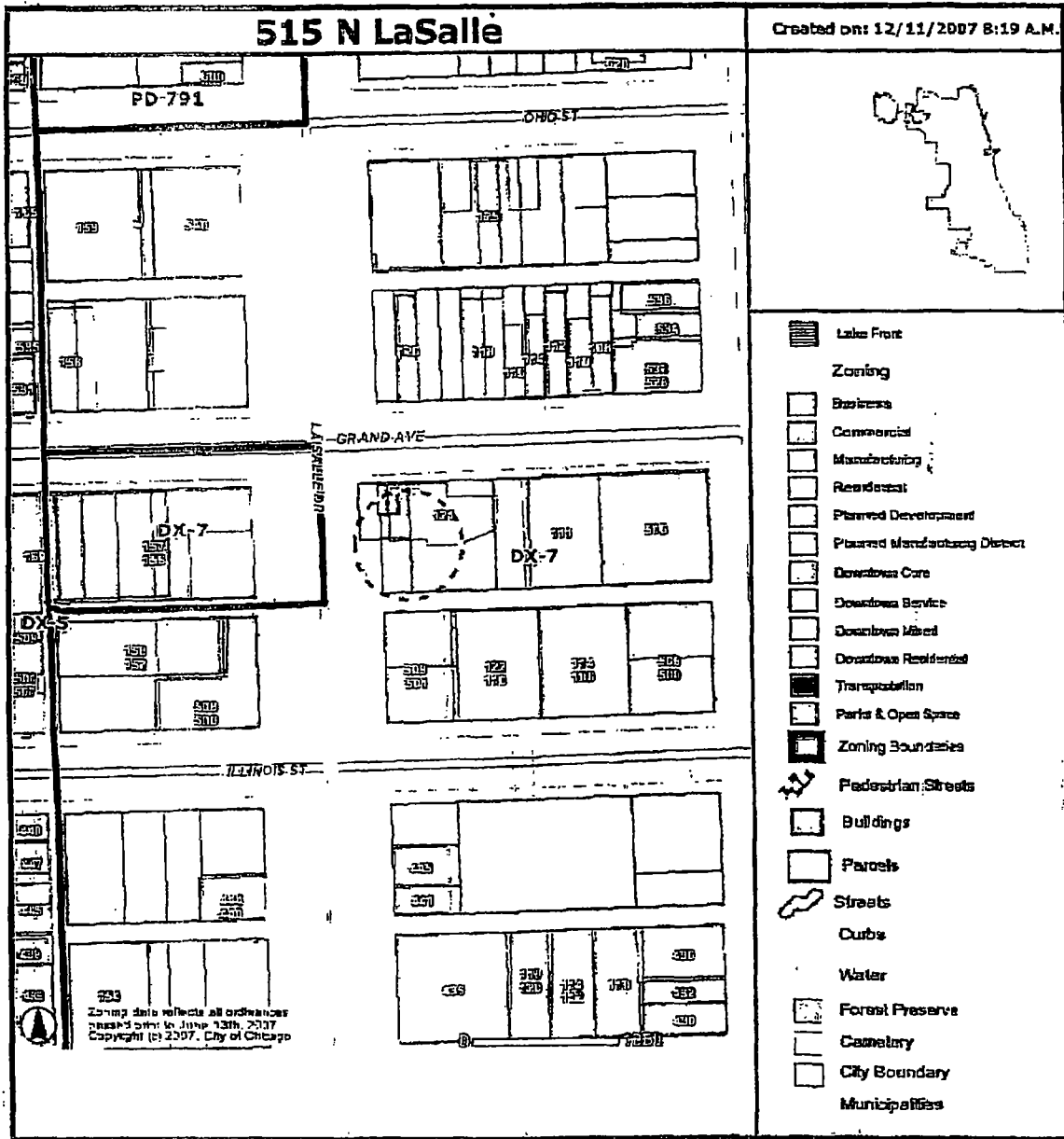

Address

515 N LA SALLE DR

Information provided on the City of Chicago web site should not be used as a substitute for legal, accounting, real estate, business, tax, or other professional advice. The City of Chicago assumes no liability for any damages or loss of any kind that might arise from the use of, misuse of, or the inability to use the City web site and/or the materials contained on the web site. The City of Chicago also assumes no liability for improper or incorrect use of materials or information contained on its web site. All materials that appear on the City of Chicago web site are distributed and transmitted as is, without warranties of any kind, either express or implied, and subject to the terms and conditions stated in this disclaimer.



City of Chicago



O2014-4789

Office of the City Clerk

Document Tracking Sheet

| | |
|---------------------------------|--|
| Meeting Date: | 5/28/2014 |
| Sponsor(s): | Reilly (42) |
| Type: | Ordinance |
| Title: | Grant(s) of privilege in public way for Bar Toma |
| Committee(s) Assignment: | Committee on Transportation and Public Way |

ORDINANCE
BAR TOMA
Acct. No. 63218 - 1
Permit No. 1111486

Be It Ordained by the City Council of the City of Chicago:

SECTION 1. Permission and authority are hereby given and granted to BAR TOMA, upon the terms and subject to the conditions of this ordinance to maintain and use, as now constructed, Occupation of Space for a glass and metal greenhouse on the public right-of-way adjacent to its premises known as 110 E. Pearson St..

Said Occupation of Space/Glass and Metal Greenhouse at E. PEARSON STREET measure(s):
One (1) at forty-eight (48) feet in length, and twelve (12) feet in width for a total of five hundred seventy-six (576) square feet. Existing glass and metal greenhouse is approximately twelve (12) feet in height.

The location of said privilege shall be as shown on prints kept on file with the Department of Business Affairs and Consumer Protection and the Office of the City Clerk.

Said privilege shall be constructed in accordance with plans and specifications approved by the Department of Planning and Development, Department of Transportation (Division of Project Development), and Department of Transportation (Office of Underground Coordination).

This grant of privilege in the public way shall be subject to the provisions of Section 10-28-015 and all other required provisions of the Municipal Code of Chicago.

The grantee shall pay to the City of Chicago as compensation for the privilege #1111486 herein granted the sum of thirty-one thousand three hundred thirty-four (\$31,334.00) per annum in advance.

A 25% penalty will be added for payments received after due date.

The permit holder agrees to hold the City of Chicago harmless for any damage, relocation or replacement costs associated with damage, relocation or removal of private property caused by the City performing work in the public way.

Authority herein given and granted for a period of five (5) years from and after 04/01/2012.

Alderman _____

Brendan Reilly 42nd Ward





City of Chicago



O2014-4791

Office of the City Clerk

Document Tracking Sheet

| | |
|---------------------------------|---|
| Meeting Date: | 5/28/2014 |
| Sponsor(s): | Reilly (42) |
| Type: | Ordinance |
| Title: | Grant(s) of privilege in public way for Boker Investment Management, Inc. |
| Committee(s) Assignment: | Committee on Transportation and Public Way |

ORDINANCE
BOKER INVESTMENT MANAGEMENT INC.
Acct. No. 17093 - 1
Permit No. 1110450

Be It Ordained by the City Council of the City of Chicago:

SECTION 1. Permission and authority are hereby given and granted to BOKER INVESTMENT MANAGEMENT INC., upon the terms and subject to the conditions of this ordinance to maintain and use, as now constructed, Occupation of Space for an curb and fence on the public right-of-way adjacent to its premises known as 660 N. Rush St..

Said Occupation of Space for an curb and fence at N. Rush measure(s):

One (1) at forty-seven (47) feet in length, and point seven eight (.78) feet in width for a total of thirty-six point six six (36.66) square feet. Existing curb and fencing encroaches the public way approximately point seven eight (.78) over the property line.

The location of said privilege shall be as shown on prints kept on file with the Department of Business Affairs and Consumer Protection and the Office of the City Clerk.

Said privilege shall be constructed in accordance with plans and specifications approved by the Department of Planning and Development, Department of Transportation (Division of Project Development), and Department of Transportation (Office of Underground Coordination).

This grant of privilege in the public way shall be subject to the provisions of Section 10-28-015 and all other required provisions of the Municipal Code of Chicago.

The grantee shall pay to the City of Chicago as compensation for the privilege #1110450 herein granted the sum of one thousand three hundred ninety-three (\$1,393.00) per annum in advance.

A 25% penalty will be added for payments received after due date.

The permit holder agrees to hold the City of Chicago harmless for any damage, relocation or replacement costs associated with damage, relocation or removal of private property caused by the City performing work in the public way.

Authority herein given and granted for a period of five (5) years from and after 01/13/2014.

Alderman _____

Brendan Reilly 42nd Ward

1

1

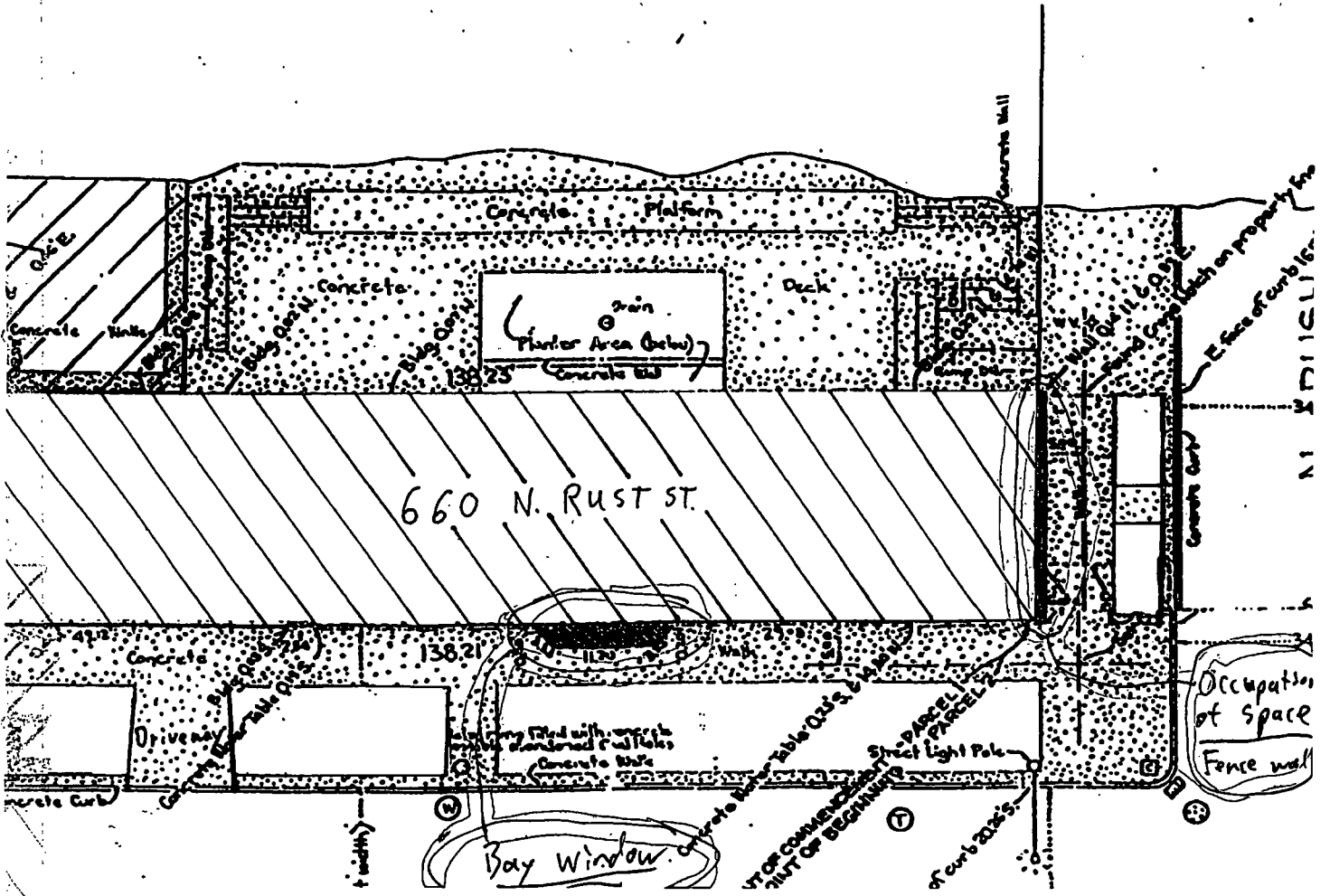



City of Chicago



O2014-4793

Office of the City Clerk Document Tracking Sheet

| | |
|---------------------------------|--|
| Meeting Date: | 5/28/2014 |
| Sponsor(s): | Reilly (42) |
| Type: | Ordinance |
| Title: | Grant(s) of privilege in public way for Camper |
| Committee(s) Assignment: | Committee on Transportation and Public Way |

ORDINANCE
CAMPER
Acct. No. 258761 - 3
Permit No. 1111876

Be It Ordained by the City Council of the City of Chicago:

SECTION 1. Permission and authority are hereby given and granted to CAMPER, upon the terms and subject to the conditions of this ordinance to maintain and use one (1) sign(s) projecting over the public right-of-way attached to its premises known as 540 N. Michigan Ave..

Said sign structure(s) measures as follows; along S. Michigan:
One (1) at two point nine six (2.96) feet in length, one point four eight (1.48) feet in height and nine (9) feet above grade level.

The location of said privilege shall be as shown on prints kept on file with the Department of Business Affairs and Consumer Protection and the Office of the City Clerk.

Said privilege shall be constructed in accordance with plans and specifications approved by the Department of Transportation (Division of Project Development) and Zoning Department - Signs.

This grant of privilege in the public way shall be subject to the provisions of Section 10-28-015 and all other required provisions of the Municipal Code of Chicago.

The grantee shall pay to the City of Chicago as compensation for the privilege #1111876 herein granted the sum of one hundred (\$100.00) per annum in advance.

A 25% penalty will be added for payments received after due date.

The permit holder agrees to hold the City of Chicago harmless for any damage, relocation or replacement costs associated with damage, relocation or removal of private property caused by the City performing work in the public way.

Authority herein given and granted for a period of five (5) years from and after Date of Passage.

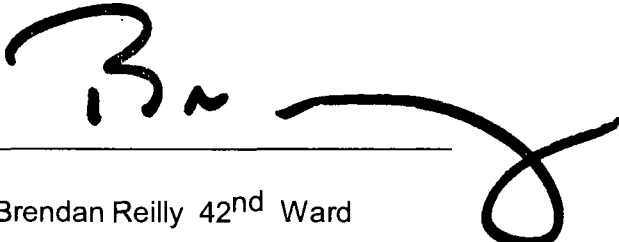
Alderman  _____
Brendan Reilly 42nd Ward

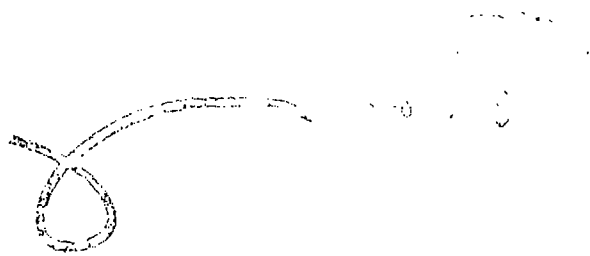

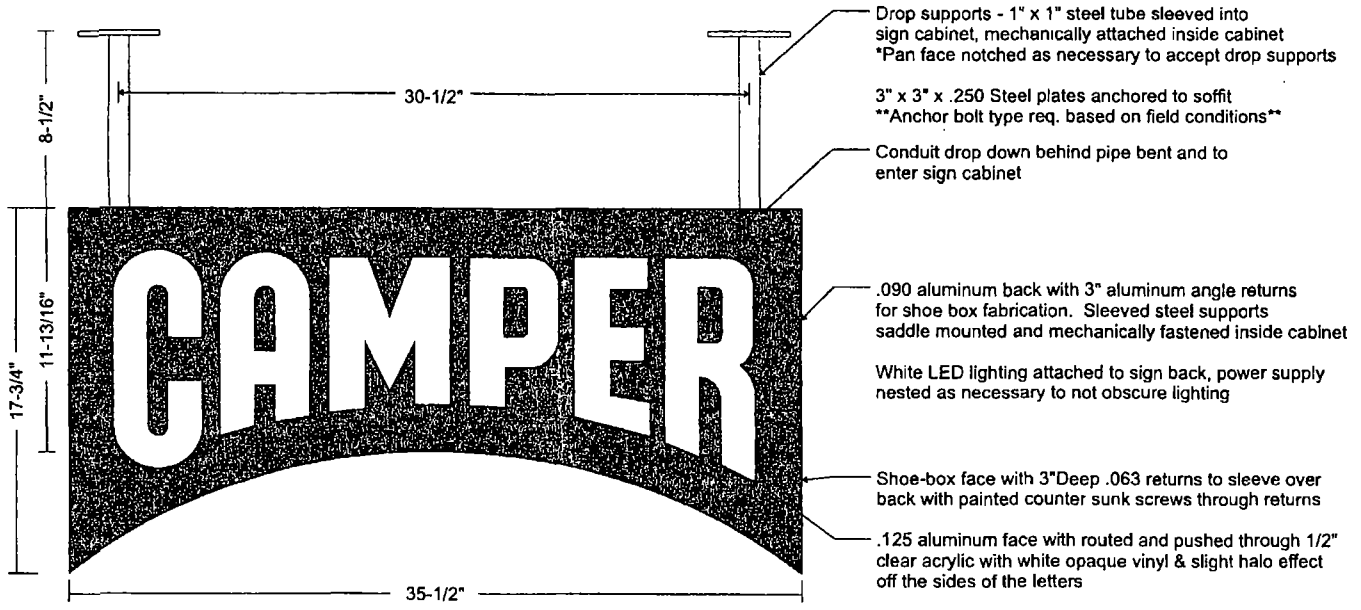

Colors to Match

Red to match
RAL 3020



Illuminated Hanging Sign
3" = 1'

| | | | | | |
|---|--------------------------|---|--------------------------|---|--|
| <p>SOUTH WATER</p> <p>SIGNS</p> <p>934 W. Church Elmhurst, IL 60120</p> <p>tel: 630 285-1943 fax: 630 222-4942</p> | <p>NAME Camper</p> | <p>DESCRIPTION Exterior Illuminated Sign 540 N. Michigan Ave. Chicago, IL</p> | <p>DATE 10/30/13</p> | <p>TIME 11:14:13 11:15:15 07:13:14 am</p> | <p>THIS DRAWING IS THE PROPERTY OF SOUTH WATER SIGNS, LLC. ALL RIGHTS OF REPRODUCTION ARE RESERVED BY SOUTH WATER SIGNS, LLC. © 2013</p> |
| | <p>DATE 10/30/13</p> | <p>TIME 11:14:13 11:15:15 07:13:14 am</p> | | | |



City of Chicago



O2014-4795

Office of the City Clerk

Document Tracking Sheet

| | |
|---------------------------------|--|
| Meeting Date: | 5/28/2014 |
| Sponsor(s): | Reilly (42) |
| Type: | Ordinance |
| Title: | Grant(s) of privilege in public way for Chicago Marriott Downtown |
| Committee(s) Assignment: | Committee on Transportation and Public Way |

ORDINANCE
CHICAGO MARRIOTT DOWNTOWN
Acct. No. 4154 - 2
Permit No. 1112994

Be It Ordained by the City Council of the City of Chicago:

SECTION 1. Permission and authority are hereby given and granted to CHICAGO MARRIOTT DOWNTOWN, upon the terms and subject to the conditions of this ordinance to maintain and use two (2) sign(s) projecting over the public right-of-way attached to its premises known as 540 N. Michigan Ave..

Said sign structure(s) measures as follows; along N. Michigan Ave:
Two (2) at three point five eight (3.58) feet in length, point one seven (.17) feet in height and twelve (12) feet above grade level.

The location of said privilege shall be as shown on prints kept on file with the Department of Business Affairs and Consumer Protection and the Office of the City Clerk.

Said privilege shall be constructed in accordance with plans and specifications approved by the Department of Transportation (Division of Project Development) and Zoning Department - Signs.

This grant of privilege in the public way shall be subject to the provisions of Section 10-28-015 and all other required provisions of the Municipal Code of Chicago.

The grantee shall pay to the City of Chicago as compensation for the privilege #1112994 herein granted the sum of one hundred seventy-five (\$175.00) per annum in advance.

A 25% penalty will be added for payments received after due date.

The permit holder agrees to hold the City of Chicago harmless for any damage, relocation or replacement costs associated with damage, relocation or removal of private property caused by the City performing work in the public way.

Authority herein given and granted for a period of five (5) years from and after 01/13/2014.

Alderman _____

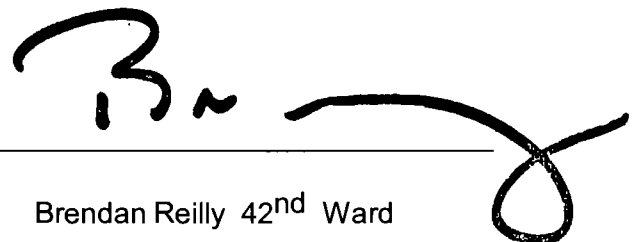
A handwritten signature in black ink, appearing to read 'B. Reilly', with a large, stylized flourish at the end.

Brendan Reilly 42nd Ward

[Faint, illegible handwritten or stamped text]

- 110' FROM NORTH EDGE OF AWNING
TO OHIO STREET

- 15' FROM BACK EDGE OF AWNING
TO SIDEWALK PLANTERS

- 29' FROM BACK EDGE OF AWNING TO
MICHIGAN AVE - CURB

- SIGN SIZES ARE CORRECT & ELEVATION
IS CORRECT

S
↑
M
I
C
H
I
G
A
N
A
V
E.
↓
N



← OHIO ST → W



City of Chicago



O2014-4796

Office of the City Clerk Document Tracking Sheet

| | |
|---------------------------------|---|
| Meeting Date: | 5/28/2014 |
| Sponsor(s): | Reilly (42) |
| Type: | Ordinance |
| Title: | Grant(s) of privilege in public way for Capital One 360 |
| Committee(s) Assignment: | Committee on Transportation and Public Way |

ORDINANCE
CAPITAL ONE 360
Acct. No. 318199 - 1
Permit No. 1108227

Be It Ordained by the City Council of the City of Chicago:

SECTION 1. Permission and authority are hereby given and granted to CAPITAL ONE 360, upon the terms and subject to the conditions of this ordinance to maintain and use, as now constructed, nine (9) Facade(s) over the public right-of-way adjacent to its premises known as 21 E. Chestnut St..

Said Facade(s) at 842 N. Wabash (column) measure(s):

One (1) at one point six seven (1.67) feet in length, nineteen (19) feet two (2) inches in height and project over public way point five (.5) feet.

Said Facade(s) at N. Wabash (horizontal) measure(s):

One (1) at nineteen point three three (19.33) feet in length, one (1) foot eight (8) inches in height and project over public way point five (.5) feet.

Said Facade(s) at N. Wabash (Column) measure(s):

One (1) at three (3) feet in length, nineteen (19) feet two (2) inches in height and project over public way point five (.5) feet.

Said Facade(s) at 852 N. Wabash (column) measure(s):

One (1) at three (3) feet in length, nineteen (19) feet two (2) inches in height and project over public way point five (.5) feet.

Said Facade(s) at N. Wabash (horizontal) measure(s):

One (1) at nineteen point three three (19.33) feet in length, one (1) foot eight (8) inches in height and project over public way point five (.5) feet.

Said Facade(s) at N. Wabash (column) measure(s):

One (1) at two point six seven (2.67) feet in length, nineteen (19) feet two (2) inches in height and project over the public way point five (.5) feet.

Said Facade(s) at 27 E. Chestnut (column) measure(s):

One (1) at one point eight three (1.83) foot in length, nineteen (19) feet two (2) inches in height and project over public way point five (.5) feet.

Said Facade(s) at E. Chestnut (horizontal) measure(s):

One (1) at thirteen point five (13.5) feet in length, one (1) feet eight (8) inches in height and project over public way point five (.5) feet.

Said Facade(s) at E. Chestnut (column) measure(s):

One (1) at one point three three (1.33) feet in length, nineteen (19) feet two (2) inches in height and project over the public way point five (.5) feet..

The location of said privilege shall be as shown on prints kept on file with the Department of Business Affairs and Consumer Protection and the Office of the City Clerk.

Said privilege shall be constructed in accordance with plans and specifications approved by the Department of Planning and Development and Department of Transportation (Division of Project Development).

This grant of privilege in the public way shall be subject to the provisions of Section 10-28-015 and all other required provisions of the Municipal Code of Chicago.

The grantee shall pay to the City of Chicago as compensation for the privilege #1108227 herein granted the sum of nine hundred ninety-two (\$992.00) per annum in advance.

A 25% penalty will be added for payments received after due date.

The permit holder agrees to hold the City of Chicago harmless for any damage, relocation or replacement costs associated with damage, relocation or removal of private property caused by the City performing work in the public way.

Authority herein given and granted for a period of five (5) years from and after 02/06/2013.

Alderman _____

Brendan Reilly 42nd Ward

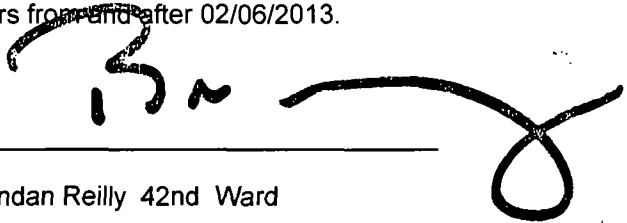
A handwritten signature in black ink, appearing to read 'B. Reilly', written over a horizontal line. The signature is stylized and includes a large loop at the end.

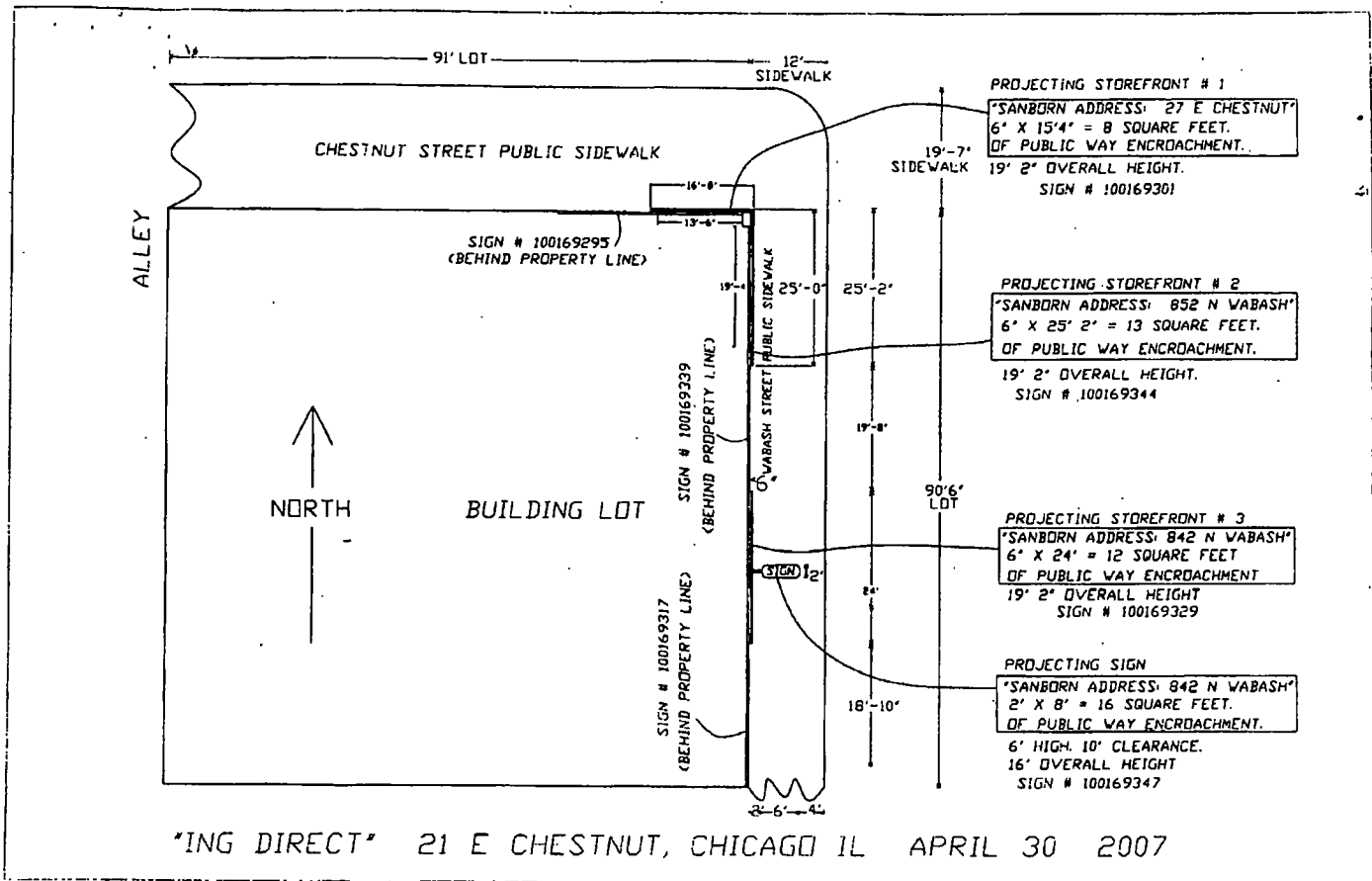

"ING DIRECT" 21 E CHESTNUT, CHICAGO IL APRIL 30 2007



City of Chicago



O2014-4799

Office of the City Clerk

Document Tracking Sheet

| | |
|---------------------------------|--|
| Meeting Date: | 5/28/2014 |
| Sponsor(s): | Reilly (42) |
| Type: | Ordinance |
| Title: | Grant(s) of privilege in public way for Courtyard by Marriott Chicago |
| Committee(s) Assignment: | Committee on Transportation and Public Way |

ORDINANCE
COURTYARD BY MARRIOTT CHICAGO
Acct. No. 310196 - 1
Permit No. 1108943

Be It Ordained by the City Council of the City of Chicago:

SECTION 1. Permission and authority are hereby given and granted to COURTYARD BY MARRIOTT CHICAGO, upon the terms and subject to the conditions of this ordinance to maintain and use, as now constructed, fifty-seven (57) Decorative Ornament(s) projecting over the public right-of-way adjacent to its premises known as 165 E. Ontario St.. Existing decorative spires ornaments are attached to the building.

Said Decorative Ornament(s) at E. Ontario Street measure(s):

Twenty (20) at three (3) feet in length, and point five (.5) feet in width for a total of thirty (30) square feet. Existing decorative spires are approximately one hundred twenty (120) to two hundred fifty (250) feet above grade level.

Said Decorative Ornament(s) at N. St Clair Street measure(s):

Eighteen (18) at three (3) feet in length, and point five (.5) feet in width for a total of twenty-seven (27) square feet. Existing decorative spires are approximately one hundred twenty (120) feet to two hundred fifty (250) feet above grade level.

Said Decorative Ornament(s) at Public Alley measure(s):

Nineteen (19) at three (3) feet in length, and point five (.5) feet in width for a total of twenty-eight point five (28.5) square feet. Existing decorative spires are approximately one hundred twenty (120) to two hundred fifty (250) feet above grade level.

The location of said privilege shall be as shown on prints kept on file with the Department of Business Affairs and Consumer Protection and the Office of the City Clerk.

Said privilege shall be constructed in accordance with plans and specifications approved by the Department of Transportation (Division of Project Development).

This grant of privilege in the public way shall be subject to the provisions of Section 10-28-015 and all other required provisions of the Municipal Code of Chicago.

The grantee shall pay to the City of Chicago as compensation for the privilege #1108943 herein granted the sum of four hundred (\$400.00) per annum in advance.

A 25% penalty will be added for payments received after due date.

The permit holder agrees to hold the City of Chicago harmless for any damage, relocation or replacement costs associated with damage, relocation or removal of private property caused by the City performing work in the public way.

Authority herein given and granted for a period of five (5) years from and after 09/10/2013.

Alderman _____

Brendan Reilly 42nd Ward

- 20TH FLOOR 207'-8"
- 19TH FLOOR 195'-9"
- 18TH FLOOR 180'-0"
- 17TH FLOOR 181'-3"
- 16TH FLOOR 172'-8"
- 15TH FLOOR 163'-9"
- 14TH FLOOR 155'-0"
- 13TH FLOOR 146'-3"
- 12TH FLOOR 137'-6"
- 11TH FLOOR 128'-9"
- 10TH FLOOR 120'-0"
- 9TH FLOOR 83'-6"
- 8TH FLOOR 82'-8"
- 7TH FLOOR 72'-0"

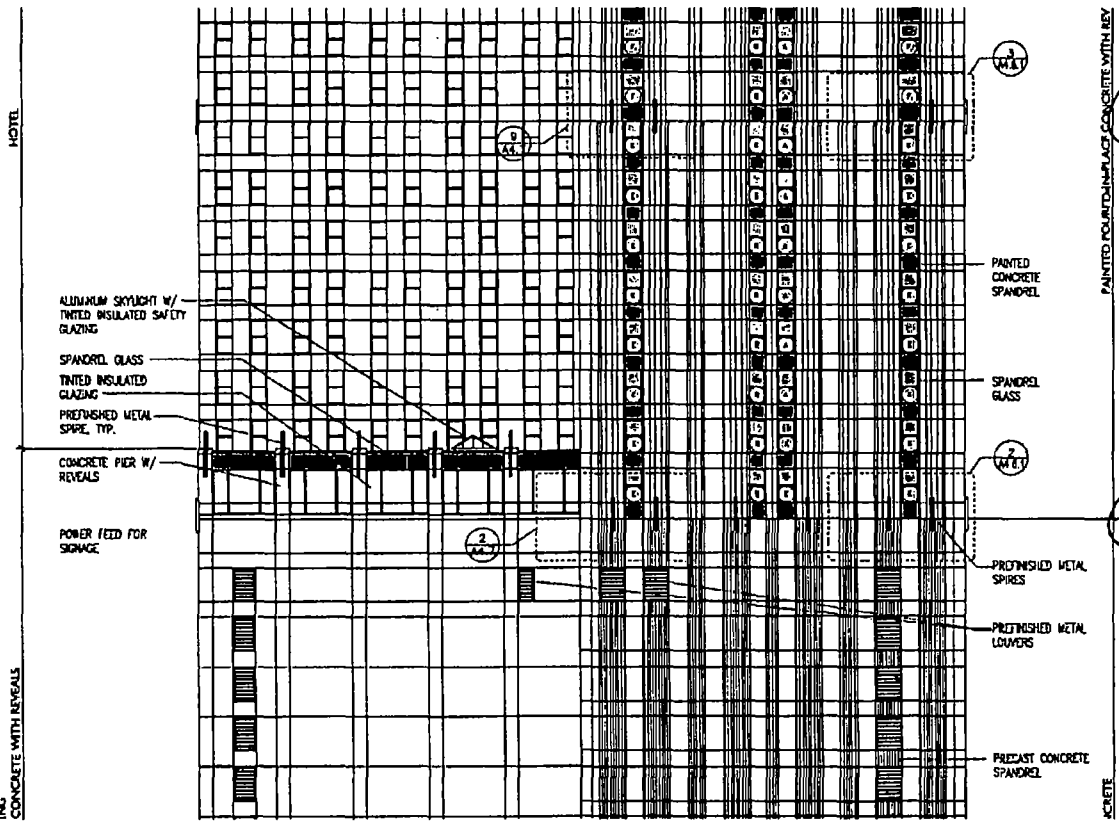

← Public Alley →

B SOUTH ELEVATION

SCALE: 1/16" = 1'-0"

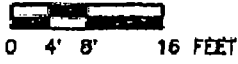

Courtyard by Marriott Chicago
 Downtown Chicago/ Magnificent Mile
 165 East Ontario Street
 Chicago, IL 60611



City of Chicago



O2014-4801

Office of the City Clerk

Document Tracking Sheet

| | |
|---------------------------------|---|
| Meeting Date: | 5/28/2014 |
| Sponsor(s): | Reilly (42) |
| Type: | Ordinance |
| Title: | Grant(s) of privilege in public way for East Bank Club - light fixtures |
| Committee(s) Assignment: | Committee on Transportation and Public Way |

ORDINANCE
EAST BANK CLUB
Acct. No. 62807 - 5
Permit No. 1112872

Be It Ordained by the City Council of the City of Chicago:

SECTION 1. Permission and authority are hereby given and granted to EAST BANK CLUB, upon the terms and subject to the conditions of this ordinance to maintain and use, as now constructed, twenty (20) Light Fixture(s) projecting over the public right-of-way adjacent to its premises known as 500 N. Kingsbury St..

Said Light Fixture(s) at N KINGSBURY ST measure(s):

Twenty (20) at three (3) feet in length, one point five (1.5) foot in width and twelve (12) feet above grade level.

The location of said privilege shall be as shown on prints kept on file with the Department of Business Affairs and Consumer Protection and the Office of the City Clerk.

Said privilege shall be constructed in accordance with plans and specifications approved by the Department of Transportation (Division of Project Development).

This grant of privilege in the public way shall be subject to the provisions of Section 10-28-015 and all other required provisions of the Municipal Code of Chicago.

The grantee shall pay to the City of Chicago as compensation for the privilege #1112872 herein granted the sum of one hundred seventy (\$170.00) per annum in advance.

A 25% penalty will be added for payments received after due date.

The permit holder agrees to hold the City of Chicago harmless for any damage, relocation or replacement costs associated with damage, relocation or removal of private property caused by the City performing work in the public way.

Authority herein given and granted for a period of five (5) years from and after 01/13/2014.

Alderman _____

Brendan Reilly 42nd Ward

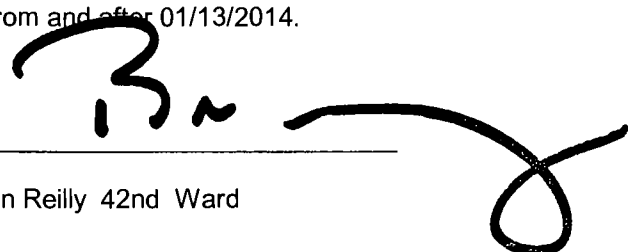
A large, stylized handwritten signature in black ink, appearing to read 'B. Reilly', is written over a horizontal line. The signature is fluid and cursive, with a large loop at the end.





City of Chicago



O2014-4803

Office of the City Clerk

Document Tracking Sheet

| | |
|---------------------------------|--|
| Meeting Date: | 5/28/2014 |
| Sponsor(s): | Reilly (42) |
| Type: | Ordinance |
| Title: | Grant(s) of privilege in public way for East Bank Club - security camera |
| Committee(s) Assignment: | Committee on Transportation and Public Way |

ORDINANCE
EAST BANK CLUB
Acct. No. 62807 - 5
Permit No. 1112870

Be It Ordained by the City Council of the City of Chicago:

SECTION 1. Permission and authority are hereby given and granted to EAST BANK CLUB, upon the terms and subject to the conditions of this ordinance to maintain and use, as now constructed, one (1) Security Camera(s) projecting over the public right-of-way for security purposes adjacent to its premises known as 500 N. Kingsbury St..

Said Security Camera(s) at N KNIGSBURY ST measure(s):

One (1) at one point five (1.5) foot in length, one (1) foot in width and thirteen point five (13.5) feet above grade level.

The location of said privilege shall be as shown on prints kept on file with the Department of Business Affairs and Consumer Protection and the Office of the City Clerk.

Said privilege shall be constructed in accordance with plans and specifications approved by the Department of Planning and Development and Department of Transportation (Division of Project Development).

This grant of privilege in the public way shall be subject to the provisions of Section 10-28-015 and all other required provisions of the Municipal Code of Chicago.

The grantee shall pay to the City of Chicago as compensation for the privilege #1112870 herein granted the sum of zero (\$.00) per annum in advance.

A 25% penalty will be added for payments received after due date.

The permit holder agrees to hold the City of Chicago harmless for any damage, relocation or replacement costs associated with damage, relocation or removal of private property caused by the City performing work in the public way.

Authority herein given and granted for a period of five (5) years from and after 01/13/2014.

Alderman _____

Brendan Reilly 42nd Ward

9

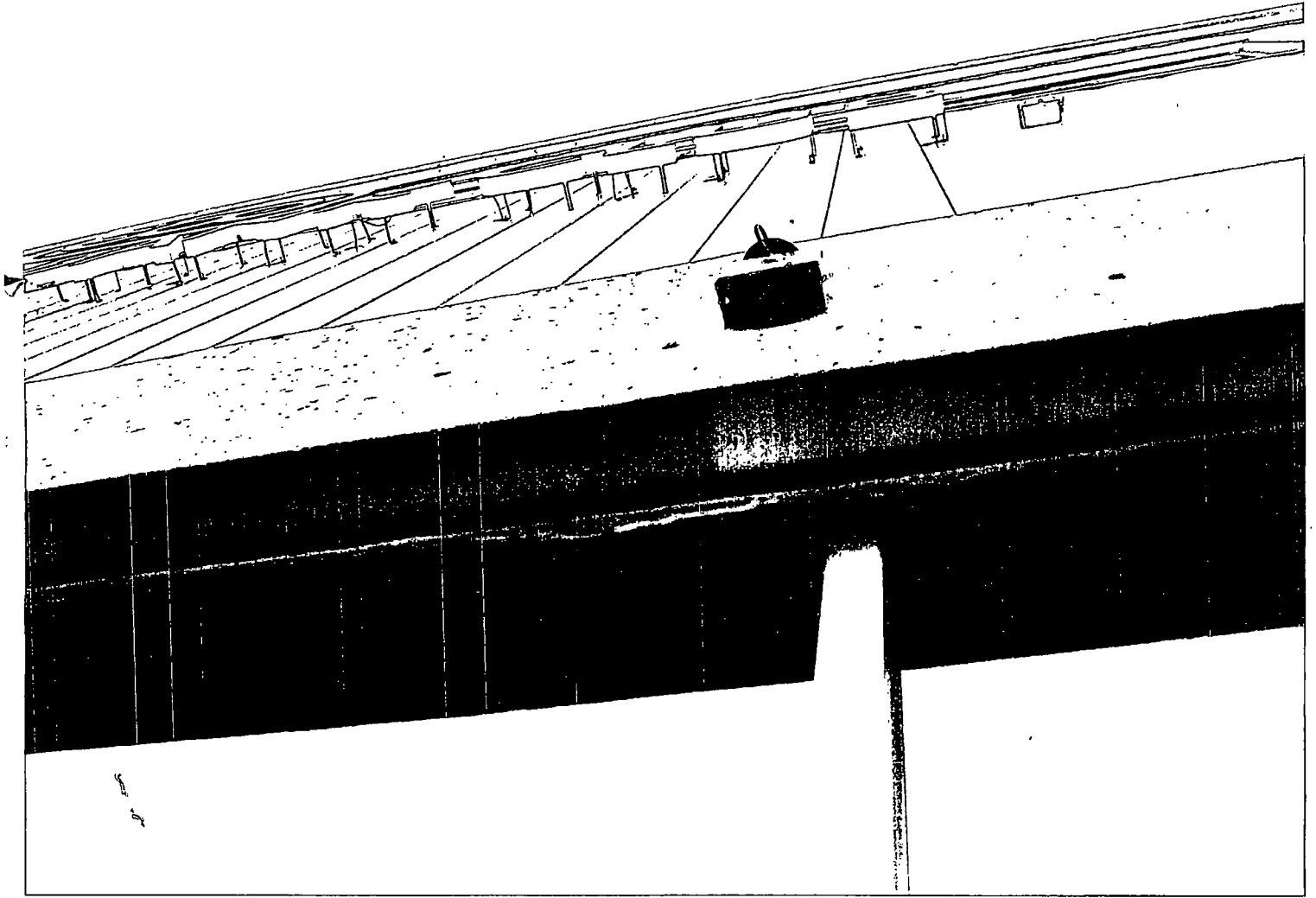



City of Chicago



O2014-4807

Office of the City Clerk Document Tracking Sheet

| | |
|---------------------------------|---|
| Meeting Date: | 5/28/2014 |
| Sponsor(s): | Reilly (42) |
| Type: | Ordinance |
| Title: | Grant(s) of privilege in public way for Eatly |
| Committee(s) Assignment: | Committee on Transportation and Public Way |

ORDINANCE
EATALY
Acct. No. 381444 - 1
Permit No. 1111640

Be It Ordained by the City Council of the City of Chicago:

SECTION 1. Permission and authority are hereby given and granted to EATALY, upon the terms and subject to the conditions of this ordinance to maintain and use two (2) sign(s) projecting over the public right-of-way attached to its premises known as 43 E. Ohio St..

Said sign structure(s) measures as follows; along 43 E. Ohio St.:
Two (2) at three point three three (3.33) feet in length, two (2) feet in height and nine (9) feet above grade level.

The location of said privilege shall be as shown on prints kept on file with the Department of Business Affairs and Consumer Protection and the Office of the City Clerk.

Said privilege shall be constructed in accordance with plans and specifications approved by the Department of Transportation (Division of Project Development) and Zoning Department - Signs.

This grant of privilege in the public way shall be subject to the provisions of Section 10-28-015 and all other required provisions of the Municipal Code of Chicago.

The grantee shall pay to the City of Chicago as compensation for the privilege #1111640 herein granted the sum of one hundred seventy-five (\$175.00) per annum in advance.

A 25% penalty will be added for payments received after due date.

The permit holder agrees to hold the City of Chicago harmless for any damage, relocation or replacement costs associated with damage, relocation or removal of private property caused by the City performing work in the public way.

Authority herein given and granted for a period of five (5) years from and after Date of Passage.

Alderman _____

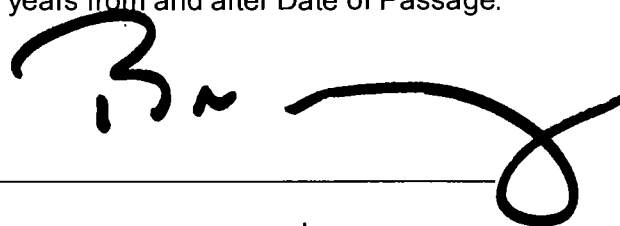

Brendan Reilly 42nd Ward

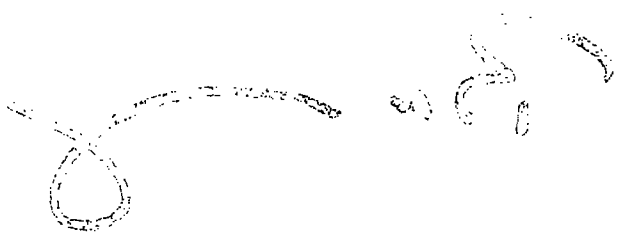

— DEPTH OF SIGN BOX

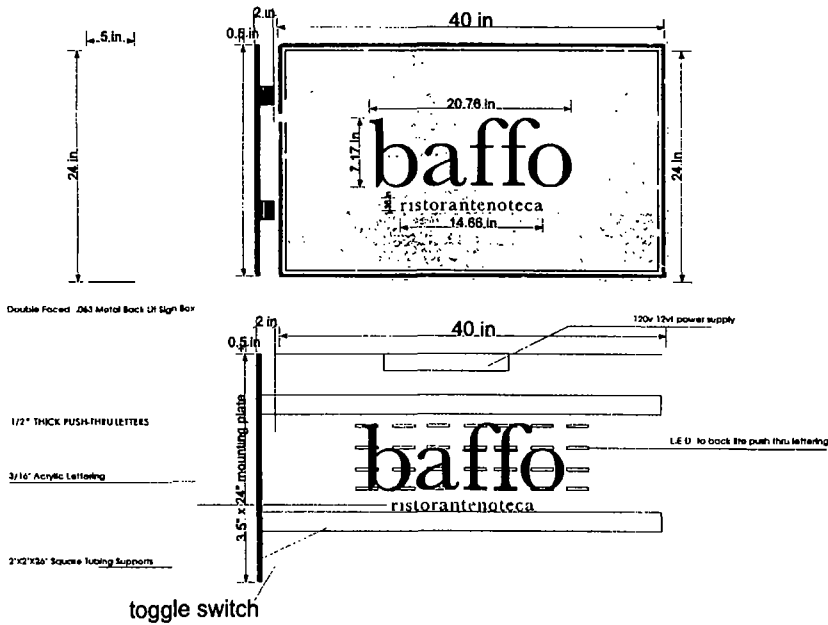

1/2" expansion bolts for installation 

This sign is intended to be installed in accordance with the requirements of Article 600 of the National Electrical Code and/or other applicable local codes.

This includes proper grounding and bonding of the sign. Sign will be U.L. certified.



****Installation To Be between the Concrete Walls Mounted On Marble. Wireway box to be built for flush finish to wall. Bracket Arms Extend from there.**

- Mounted At Least 9 Ft From Ground To Bottom of Sign.
- All screws/bolts to be counter-sunk for a flush finish.
- ****All electric must be provided to each install location prior to signage installation.**

| | |
|-----------|----|
| Designer. | DW |
| Rev | X |
| | X |
| | X |
| | X |

Location: _____
 Address: _____
 Date: _____

Approval:

| | | |
|--------|-----------|-----------|
| i.D. # | Artwork # | Drawing # |
| - | As Shown | |



City of Chicago



O2014-4809

Office of the City Clerk

Document Tracking Sheet

| | |
|---------------------------------|--|
| Meeting Date: | 5/28/2014 |
| Sponsor(s): | Reilly (42) |
| Type: | Ordinance |
| Title: | Grant(s) of privilege in public way for Equity Office Properties Management Corporation |
| Committee(s) Assignment: | Committee on Transportation and Public Way |

ORDINANCE
EQUITY OFFICE PROPERTIES MANAGEMENT CORP.
Acct. No. 4856 - 2
Permit No. 1112168

Be It Ordained by the City Council of the City of Chicago:

SECTION 1. Permission and authority are hereby given and granted to EQUITY OFFICE PROPERTIES MANAGEMENT CORP., upon the terms and subject to the conditions of this ordinance to maintain and use, as now constructed, one (1) Vault(s) under the public right-of-way adjacent to its premises known as 2 N. Riverside Plz..

Said Vault(s) at N. Canal Street measure(s):

One (1) at three hundred sixty-two point three eight (362.38) feet in length, and twenty (20) feet in width for a total of seven thousand two hundred forty-seven point six (7247.6) square feet. Existing vault beneath the public way is used to house building water, steam, sewer piping, electrical power and storage.

The location of said privilege shall be as shown on prints kept on file with the Department of Business Affairs and Consumer Protection and the Office of the City Clerk.

Said privilege shall be constructed in accordance with plans and specifications approved by the Department of Transportation (Office of Underground Coordination).

This grant of privilege in the public way shall be subject to the provisions of Section 10-28-015 and all other required provisions of the Municipal Code of Chicago.

The grantee shall pay to the City of Chicago as compensation for the privilege #1112168 herein granted the sum of thirty-two thousand four hundred sixty-nine (\$32,469.00) per annum in advance.

A 25% penalty will be added for payments received after due date.

The permit holder agrees to hold the City of Chicago harmless for any damage, relocation or replacement costs associated with damage, relocation or removal of private property caused by the City performing work in the public way.

Authority herein given and granted for a period of five (5) years from and after 04/25/2014.

Alderman _____

Brendan Reilly 42nd Ward

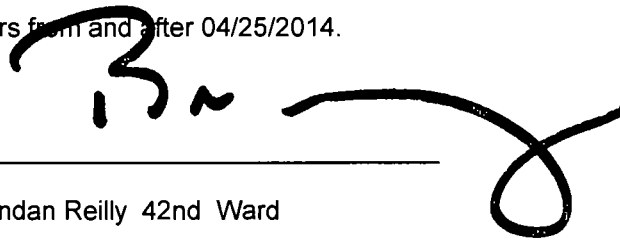
A large, stylized handwritten signature in black ink, appearing to read 'B. Reilly', is written over the signature line and extends to the right.

Handwritten scribbles and marks, possibly a signature or initials, located in the lower-left quadrant of the page.

Faint vertical text or markings along the right edge of the page, possibly bleed-through from the reverse side.

WASHINGTON

MADISON

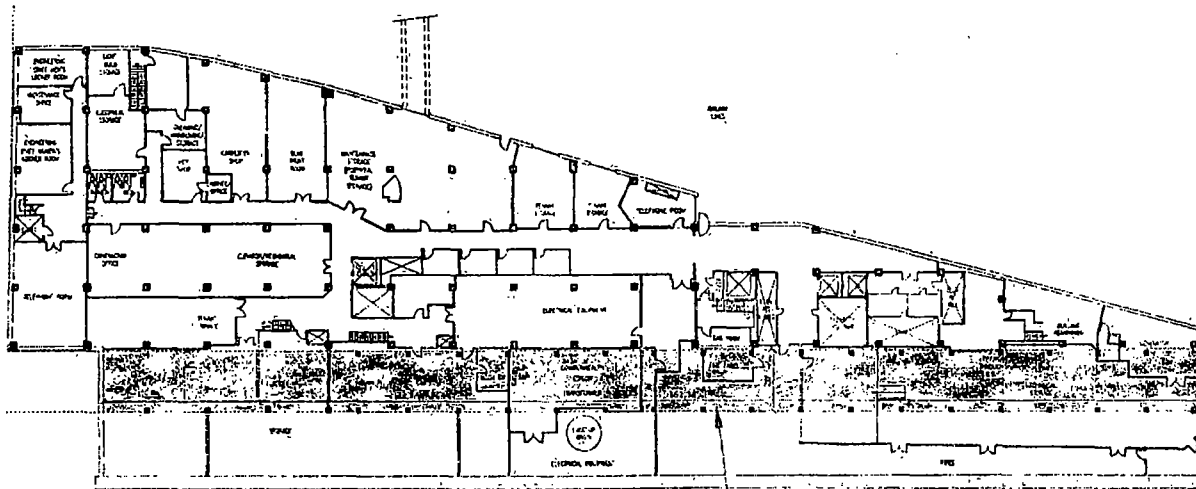

1 B1 FLOOR PLAN
NOT TO SCALE

AREA BELOW PUBLIC
RIGHT OF WAY

CANAL



Fitzgerald Earles Architects and Associates
 1820 W. Hubbard, Suite 320, Chicago, Illinois 60622
 312.491.9840 (t)312.491.9844 | www.feaa-chicago.com

CLIENT: EQUITY OFFICE PROPERTIES - 2 N. RIVERSIDE

RSF: N/A

SKETCH NO: SK.1R

PROJECT NO: 11065.00

FILE NAME: 2NR-B1 VAULT 20110110.DWG

DRAWN BY: MK DATE 3.16.2011



City of Chicago



O2014-4811

Office of the City Clerk

Document Tracking Sheet

| | |
|---------------------------------|---|
| Meeting Date: | 5/28/2014 |
| Sponsor(s): | Reilly (42) |
| Type: | Ordinance |
| Title: | Grant(s) of privilege in public way for Gibsons LLC |
| Committee(s) Assignment: | Committee on Transportation and Public Way |

ORDINANCE
GIBSONS L.L.C.
Acct. No. 64192 - 3
Permit No. 1112896

Be It Ordained by the City Council of the City of Chicago:

SECTION 1. Permission and authority are hereby given and granted to GIBSONS L.L.C., upon the terms and subject to the conditions of this ordinance to maintain and use, as now constructed, one (1) Balcony(s) projecting over the public right-of-way adjacent to its premises known as 1027 N. State St..

Said Balcony(s) at N. STATE ST. measure(s):

One (1) at fourteen point six (14.6) feet in length, and three point six (3.6) feet in width for a total of fifty-two point five six (52.56) square feet.

The location of said privilege shall be as shown on prints kept on file with the Department of Business Affairs and Consumer Protection and the Office of the City Clerk.

Said privilege shall be constructed in accordance with plans and specifications approved by the Department of Planning and Development and Department of Transportation (Division of Project Development).

This grant of privilege in the public way shall be subject to the provisions of Section 10-28-015 and all other required provisions of the Municipal Code of Chicago.

The grantee shall pay to the City of Chicago as compensation for the privilege #1112896 herein granted the sum of seventy-five (\$75.00) per annum in advance.

A 25% penalty will be added for payments received after due date.

The permit holder agrees to hold the City of Chicago harmless for any damage, relocation or replacement costs associated with damage, relocation or removal of private property caused by the City performing work in the public way.

Authority herein given and granted for a period of five (5) years from and after 04/21/2014.

Alderman _____

Brendan Reilly 42nd Ward

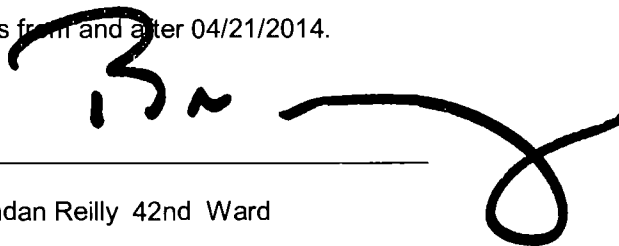

Handwritten scribbles and marks, possibly including a small circle and some faint lines.

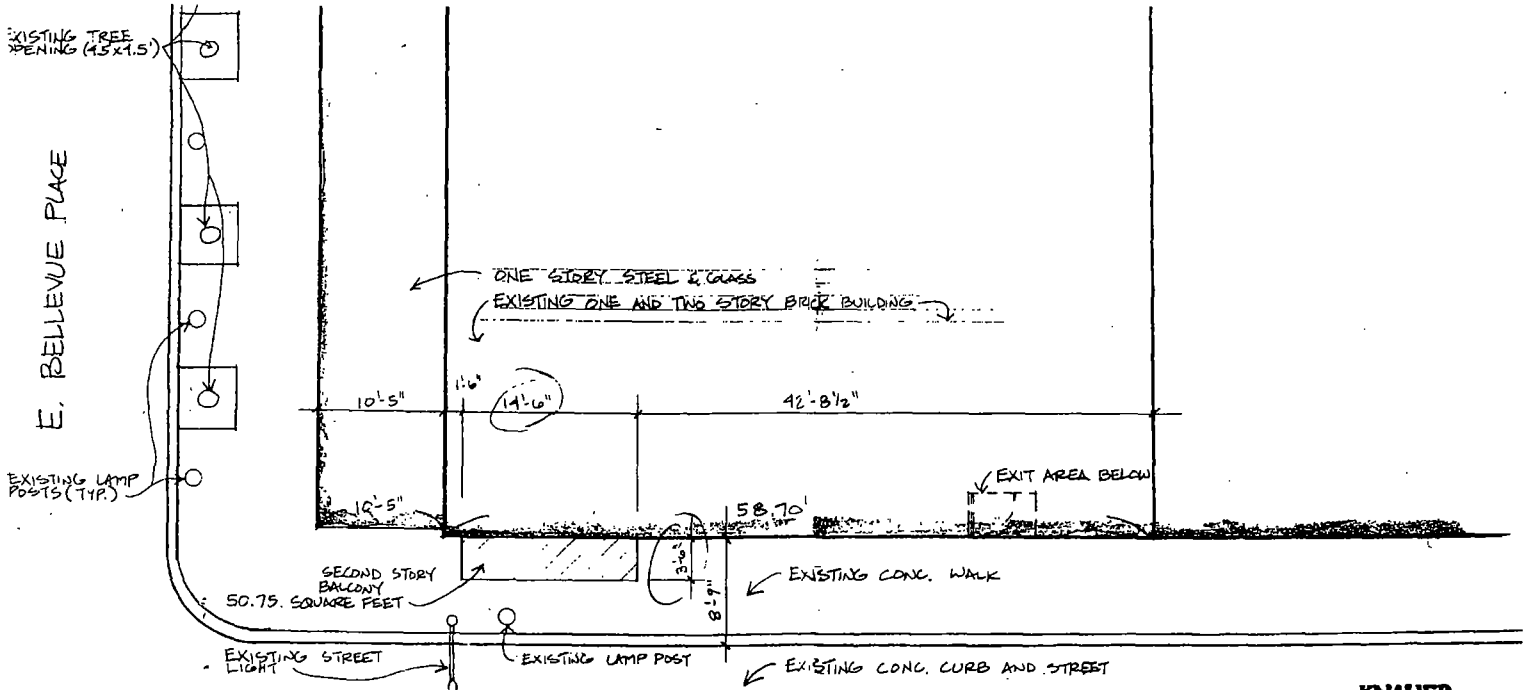

E. BELLEVUE PLACE

EXISTING TREE OPENING (4.5x1.5)

EXISTING LAMP POSTS (TYP.)

ONE STORY STEEL & GLASS
EXISTING ONE AND TWO STORY BRICK BUILDING

10'-5"

14'-6"

42'-8 1/2"

19'-5"

58'-7 1/2"

EXIT AREA BELOW

SECOND STORY BALCONY
50.75 SQUARE FEET

EXISTING CONC. WALK

EXISTING STREET LIGHT

EXISTING LAMP POST

EXISTING CONC. CURB AND STREET



GIBSON'S BALCONY PLAN
 1068 N. RUSH STREET SCALE: 1/8" = 1'-0"
 12/03/98

NORTH STATE STREET

KNAUER

KNAUER INCORPORATED
 1100 N. RUSH STREET
 CHICAGO, ILL. 60611
 TEL. (312) 329-1100
 OCCUPATIONAL SAFETY & HEALTH



City of Chicago



O2014-4813

Office of the City Clerk

Document Tracking Sheet

| | |
|---------------------------------|---|
| Meeting Date: | 5/28/2014 |
| Sponsor(s): | Reilly (42) |
| Type: | Ordinance |
| Title: | Grant(s) of privilege in public way for GLL Properties 444 North Michigan L.P. |
| Committee(s) Assignment: | Committee on Transportation and Public Way |

ORDINANCE
GLL PROPERTIES 444 NORTH MICHIGAN, L.P.
Acct. No. 330575 - 1
Permit No. 1111054

Be It Ordained by the City Council of the City of Chicago:

SECTION 1. Permission and authority are hereby given and granted to GLL PROPERTIES 444 NORTH MICHIGAN, L.P., upon the terms and subject to the conditions of this ordinance to maintain and use, as now constructed, Occupation of Space on the public right-of-way adjacent to its premises known as 444 N. Michigan Ave.. Existing occupation of space is used for an wrought iron fence on lower North Michigan Avenue with an emergency generator within the enclosed area.

Said Occupation of Space(s) at Lower N. Michigan Avenue measure(s):

One (1) at eighty-eight point two five (88.25) feet in length, and thirty-three point seven five (33.75) feet in width for a total of two thousand nine hundred seventy-eight point four four (2978.44) square feet.

Enclosure of this area of the right-of-way will provide additional security and safety for the occupants of the office building.

The location of said privilege shall be as shown on prints kept on file with the Department of Business Affairs and Consumer Protection and the Office of the City Clerk.

Said privilege shall be constructed in accordance with plans and specifications approved by the Department of Planning and Development, Department of Transportation (Division of Project Development), and Department of Transportation (Office of Underground Coordination).

This grant of privilege in the public way shall be subject to the provisions of Section 10-28-015 and all other required provisions of the Municipal Code of Chicago.

The grantee shall pay to the City of Chicago as compensation for the privilege #1111054 herein granted the sum of six thousand six hundred seventy-one (\$6,671.00) per annum in advance.

A 25% penalty will be added for payments received after due date.

The permit holder agrees to hold the City of Chicago harmless for any damage, relocation or replacement costs associated with damage, relocation or removal of private property caused by the City performing work in the public way.

Authority herein given and granted for a period of five (5) years from and after 01/13/2014.

Alderman _____

Brendan Reilly 42nd Ward

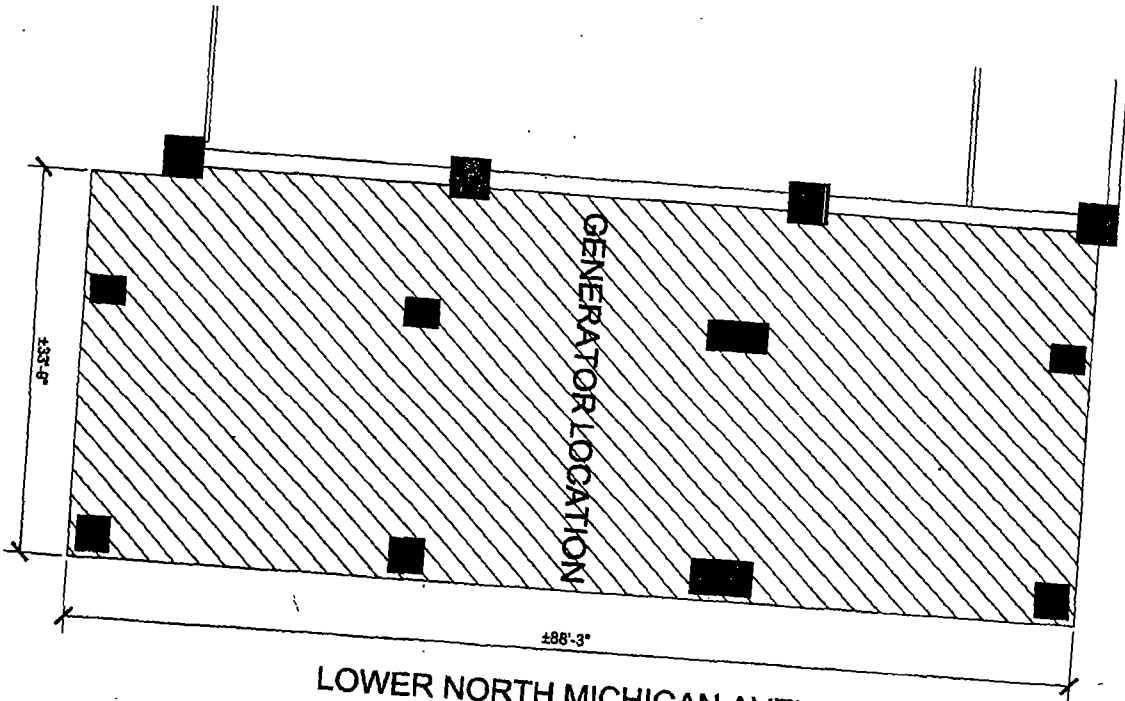

9

LOWER NORTH MICHIGAN AVENUE

| | |
|------------|----------|
| NO. | 10-13-00 |
| DATE | 9-25-00 |
| DOCUMENT 1 | |

APPROVAL
10/13/00



City of Chicago



O2014-4815

Office of the City Clerk

Document Tracking Sheet

| | |
|---------------------------------|---|
| Meeting Date: | 5/28/2014 |
| Sponsor(s): | Reilly (42) |
| Type: | Ordinance |
| Title: | Grant(s) of privilege in public way for Hotel Allegro - earth retention systems |
| Committee(s) Assignment: | Committee on Transportation and Public Way |

ORDINANCE
HOTEL ALLEGRO
Acct. No. 314818 - 1
Permit No. 1112847

Be It Ordained by the City Council of the City of Chicago:

SECTION 1. Permission and authority are hereby given and granted to HOTEL ALLEGRO, upon the terms and subject to the conditions of this ordinance to maintain and use, as now constructed, two (2) Earth Retention System(s) under the public right-of-way adjacent to its premises known as 171 W. Randolph St..

Said Earth Retention System(s) at Wells St measure(s):

One (1) at twenty-four (24) feet in length, and one point two five (1.25) foot in width for a total of thirty (30) square feet. Existing earth retention system is approximately thirty-two (32) feet below grade level.

Said Earth Retention System(s) at W Court Pl measure(s):

One (1) at twenty-eight (28) feet in length, and one point four two (1.42) foot in width for a total of thirty-nine point seven six (39.76) square feet. Existing earth retention system is approximately thirty-two (32) feet below grade level.

The location of said privilege shall be as shown on prints kept on file with the Department of Business Affairs and Consumer Protection and the Office of the City Clerk.

Said privilege shall be constructed in accordance with plans and specifications approved by the Department of Transportation (Office of Underground Coordination).

This grant of privilege in the public way shall be subject to the provisions of Section 10-28-015 and all other required provisions of the Municipal Code of Chicago.

The grantee shall pay to the City of Chicago as compensation for the privilege #1112847 herein granted the sum of eight hundred (\$800.00) per annum in advance.

A 25% penalty will be added for payments received after due date.

The permit holder agrees to hold the City of Chicago harmless for any damage, relocation or replacement costs associated with damage, relocation or removal of private property caused by the City performing work in the public way.

Authority herein given and granted for a period of five (5) years from and after 05/13/2014.

Alderman _____

Brendan Reilly 42nd Ward

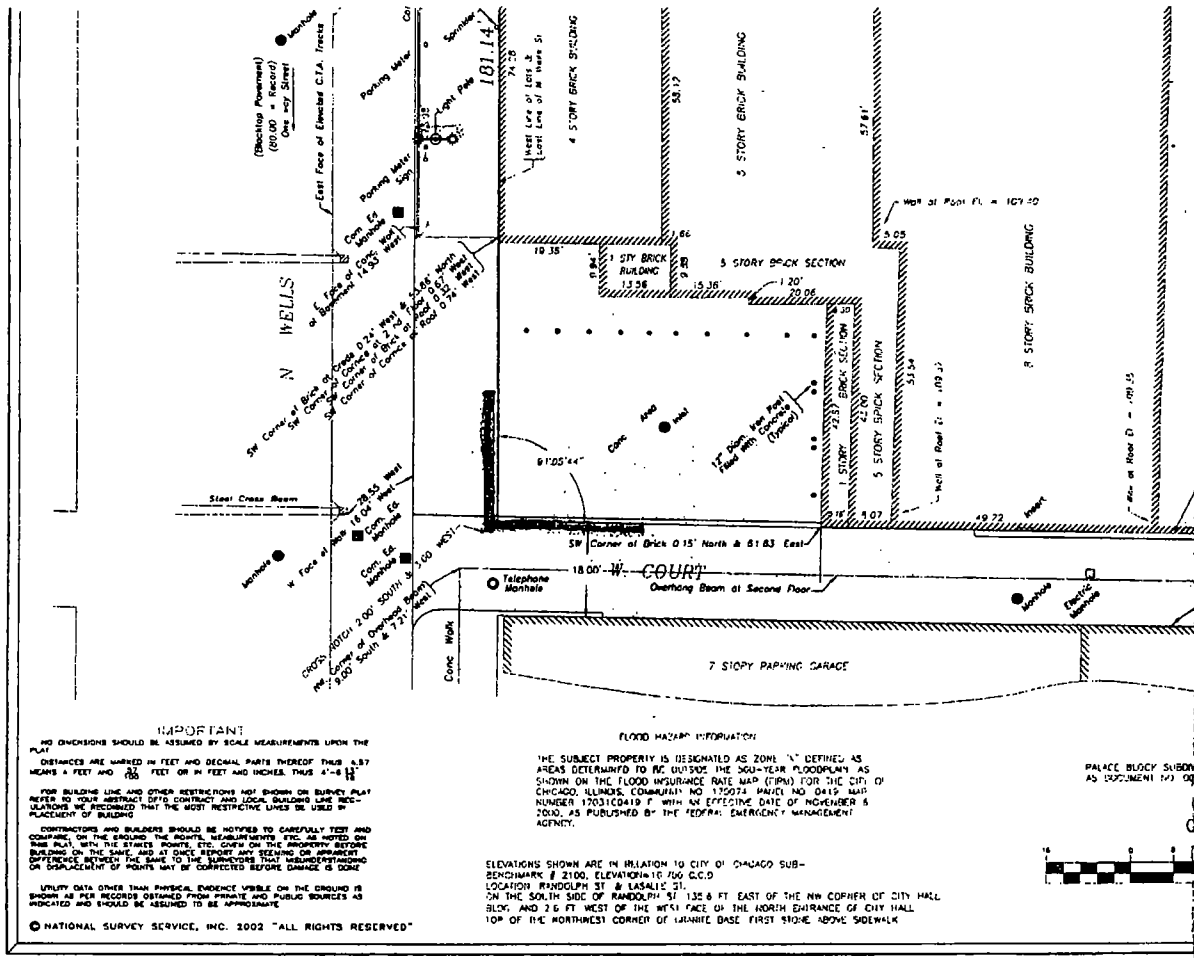

IMPORTANT

NO DIMENSIONS SHOULD BE ASSUMED BY SCALE MEASUREMENTS UPON THE PLAN.

DISTANCES ARE MARKED IN FEET AND DECIMAL PARTS THEREOF. THUS 4.87 MEANS 4 FEET AND $\frac{87}{100}$ FEET OR IN FEET AND INCHES, THUS 4'-8 $\frac{7}{16}$ ".

FOR BUILDING LINE AND OTHER RESTRICTIONS NOT SHOWN ON SURVEY PLAN REFER TO YOUR ABSTRACT OF THIS CONTRACT AND LOCAL BUILDING LINE REGULATIONS. WE RECOMMEND THAT THE MOST RESTRICTIVE LINES BE USED IN PLACEMENT OF BUILDING.

CONTRACTORS AND BUILDERS SHOULD BE NOTICED TO CAREFULLY TEST AND COMPARE ON THE GROUND THE RIGHTS, REQUIREMENTS, ETC. AS NOTED ON THIS PLAN WITH THE STAKES, POINTS, ETC. GIVEN ON THE PROPERTY BEFORE BUILDING ON THE SAME, AND AT ONCE REPORT ANY VARIATION OR APPARENT DIFFERENCE BETWEEN THE SAME TO THE SURVEYORS THAT HELD THE INSTRUMENT OR DISPLACEMENT OF POINTS MAY BE CORRECTED BEFORE DAMAGE IS DONE.

UTILITY DATA OTHER THAN PHYSICAL EVIDENCE VISIBLE ON THE GROUND IS SHOWN AS PER RECORDS OBTAINED FROM PRIVATE AND PUBLIC SOURCES AS INDICATED AND SHOULD BE ASSUMED TO BE APPROXIMATE.

© NATIONAL SURVEY SERVICE, INC. 2002 "ALL RIGHTS RESERVED"

FLOOD HAZARD INFORMATION

THE SUBJECT PROPERTY IS DESIGNATED AS ZONE "A" DEFINED AS AREAS DETERMINED TO BE OUTSIDE THE 500-YEAR FLOODPLAIN AS SHOWN ON THE FLOOD INSURANCE RATE MAP (FIRM) FOR THE CITY OF CHICAGO, ILLINOIS, COMMUNITY NO. 170074 PANEL NO. 0419 MAP NUMBER 17031C0419 F WITH AN EFFECTIVE DATE OF NOVEMBER 8 2004 AS PUBLISHED BY THE FEDERAL EMERGENCY MANAGEMENT AGENCY.

ELEVATIONS SHOWN ARE IN RELATION TO CITY OF CHICAGO SUB-BENCHMARK # 2100, ELEVATION 167.00 C.G.D.

LOCATION RANDOLPH ST & LASALLE ST, ON THE SOUTH SIDE OF RANDOLPH ST 132.8 FT EAST OF THE NW CORNER OF CITY HALL BLOCK AND 2.6 FT WEST OF THE WEST FACE OF THE NORTH ENTRANCE OF CITY HALL TOP OF THE NORTHWEST CORNER OF MARINE BASE FIRST STONE ABOVE SIDEWALK.

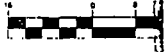



City of Chicago



O2014-4818

Office of the City Clerk Document Tracking Sheet

| | |
|---------------------------------|--|
| Meeting Date: | 5/28/2014 |
| Sponsor(s): | Reilly (42) |
| Type: | Ordinance |
| Title: | Grant(s) of privilege in public way for Hotel Allegro - flagpoles |
| Committee(s) Assignment: | Committee on Transportation and Public Way |

ORDINANCE
HOTEL ALLEGRO
Acct. No. 314818 - 1
Permit No. 1112828

Be It Ordained by the City Council of the City of Chicago:

SECTION 1. Permission and authority are hereby given and granted to HOTEL ALLEGRO, upon the terms and subject to the conditions of this ordinance to maintain and use, as now constructed, three (3) Flag Pole(s) projecting over the public right-of-way adjacent to its premises known as 171 W. Randolph St..

Said Flag Pole(s) at W. Randolph Street measure(s):

Two (2) at sixteen (16) feet in length, and one (1) foot in width for a total of thirty-two (32) square feet.

One (1) at sixteen (16) feet in length, and one (1) foot in width for a total of sixteen (16) square feet.

The location of said privilege shall be as shown on prints kept on file with the Department of Business Affairs and Consumer Protection and the Office of the City Clerk.

Said privilege shall be constructed in accordance with plans and specifications approved by the Department of Transportation (Division of Project Development).

This grant of privilege in the public way shall be subject to the provisions of Section 10-28-015 and all other required provisions of the Municipal Code of Chicago.

The grantee shall pay to the City of Chicago as compensation for the privilege #1112828 herein granted the sum of two hundred twenty-five (\$225.00) per annum in advance.

A 25% penalty will be added for payments received after due date.

The permit holder agrees to hold the City of Chicago harmless for any damage, relocation or replacement costs associated with damage, relocation or removal of private property caused by the City performing work in the public way.

Authority herein given and granted for a period of five (5) years from and after 05/13/2014.

Alderman _____

Brendan Reilly 42nd Ward

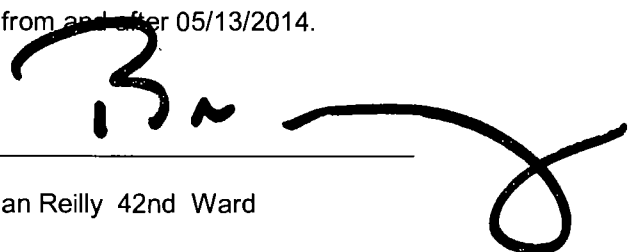
A large, stylized handwritten signature in black ink, appearing to read 'B. Reilly', is written over the signature line and extends to the right.

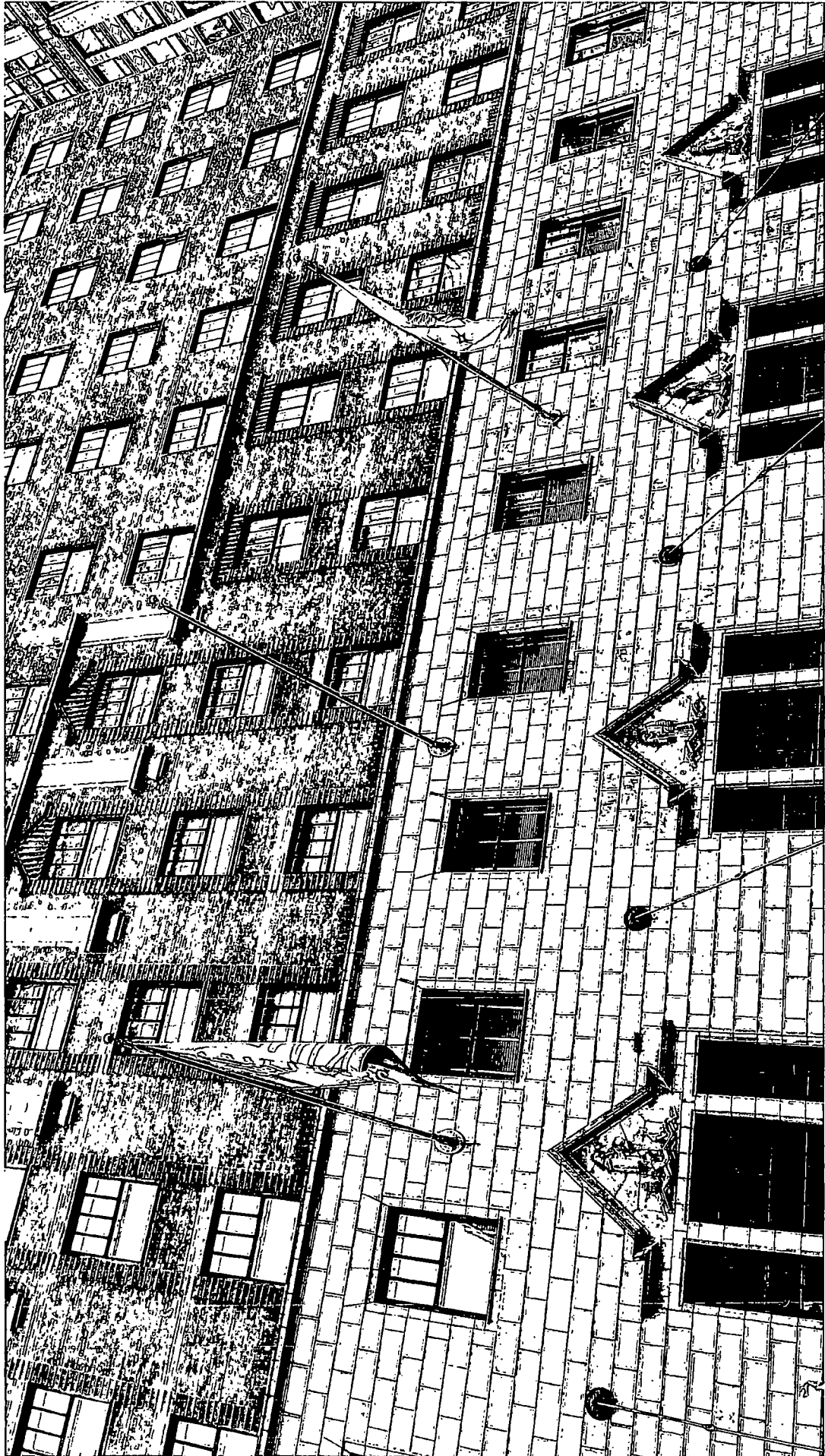



City of Chicago



O2014-4819

Office of the City Clerk

Document Tracking Sheet

| | |
|---------------------------------|--|
| Meeting Date: | 5/28/2014 |
| Sponsor(s): | Reilly (42) |
| Type: | Ordinance |
| Title: | Grant(s) of privilege in public way for Hotel Allegro - vaults |
| Committee(s) Assignment: | Committee on Transportation and Public Way |

ORDINANCE
HOTEL ALLEGRO
Acct. No. 314818 - 1
Permit No. 1112831

Be It Ordained by the City Council of the City of Chicago:

SECTION 1. Permission and authority are hereby given and granted to HOTEL ALLEGRO, upon the terms and subject to the conditions of this ordinance to maintain and use, as now constructed, two (2) Vault(s) under the public right-of-way adjacent to its premises known as 171 W. Randolph St..

Said Vault(s) at W. Randolph Street measure(s):

One (1) at two hundred fifty-six (256) feet in length, and fifteen point five (15.5) feet in width for a total of three thousand nine hundred sixty-eight (3968) square feet.

Said Vault(s) at N. Wells Street measure(s):

One (1) at one hundred thirty-three point five (133.5) feet in length, and fifteen point five (15.5) feet in width for a total of two thousand sixty-nine point two five (2069.25) square feet.

The location of said privilege shall be as shown on prints kept on file with the Department of Business Affairs and Consumer Protection and the Office of the City Clerk.

Said privilege shall be constructed in accordance with plans and specifications approved by the Department of Transportation (Office of Underground Coordination).

This grant of privilege in the public way shall be subject to the provisions of Section 10-28-015 and all other required provisions of the Municipal Code of Chicago.

The grantee shall pay to the City of Chicago as compensation for the privilege #1112831 herein granted the sum of thirty-three thousand four hundred fifty (\$33,450.00) per annum in advance.

A 25% penalty will be added for payments received after due date.

The permit holder agrees to hold the City of Chicago harmless for any damage, relocation or replacement costs associated with damage, relocation or removal of private property caused by the City performing work in the public way.

Authority herein given and granted for a period of five (5) years from and after 05/13/2014.

Alderman _____

Brendan Reilly 42nd Ward

100

100

100

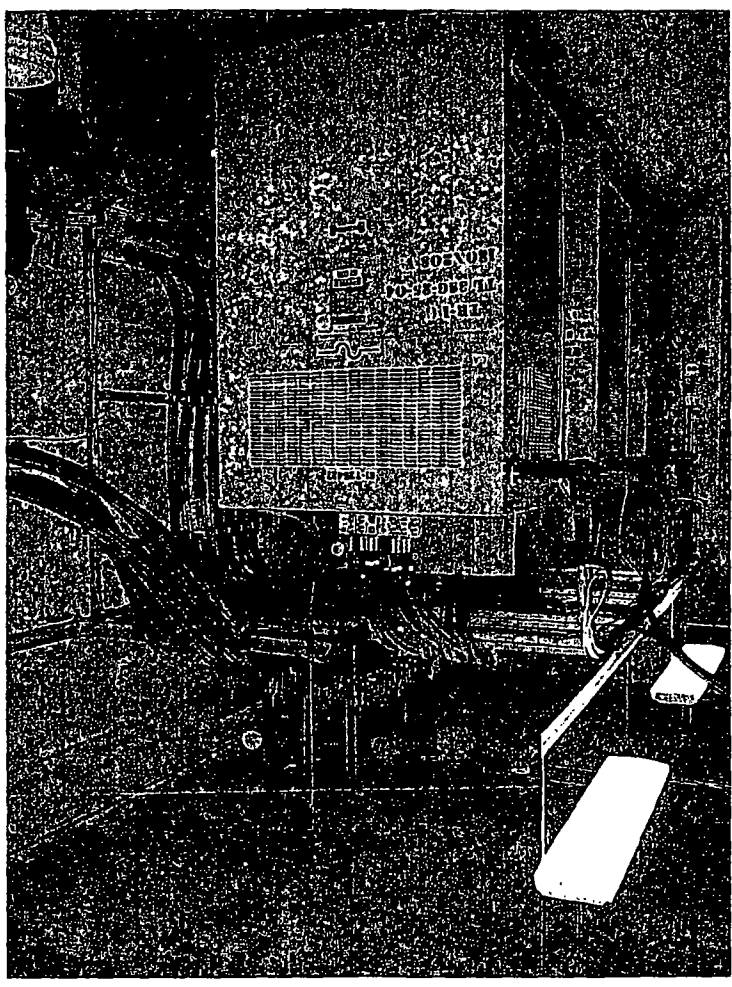



City of Chicago



O2014-4822

Office of the City Clerk
Document Tracking Sheet

| | |
|---------------------------------|---|
| Meeting Date: | 5/28/2014 |
| Sponsor(s): | Reilly (42) |
| Type: | Ordinance |
| Title: | Grant(s) of privilege in public way for Hugo's Frog Bar |
| Committee(s) Assignment: | Committee on Transportation and Public Way |

ORDINANCE
HUGO'S FROG BAR
Acct. No. 12619 - 1
Permit No. 1112898

Be It Ordained by the City Council of the City of Chicago:

SECTION 1. Permission and authority are hereby given and granted to HUGO'S FROG BAR, upon the terms and subject to the conditions of this ordinance to maintain and use, as now constructed, four (4) Balcony(s) projecting over the public right-of-way adjacent to its premises known as 1024 N. Rush St..

Said Balcony(s) at N. RUSH ST. measure(s):

Four (4) at eight point five (8.5) feet in length, and four (4) feet in width for a total of one hundred thirty-six (136) square feet.

The location of said privilege shall be as shown on prints kept on file with the Department of Business Affairs and Consumer Protection and the Office of the City Clerk.

Said privilege shall be constructed in accordance with plans and specifications approved by the Department of Planning and Development and Department of Transportation (Division of Project Development).

This grant of privilege in the public way shall be subject to the provisions of Section 10-28-015 and all other required provisions of the Municipal Code of Chicago.

The grantee shall pay to the City of Chicago as compensation for the privilege #1112898 herein granted the sum of three hundred (\$300.00) per annum in advance.

A 25% penalty will be added for payments received after due date.

The permit holder agrees to hold the City of Chicago harmless for any damage, relocation or replacement costs associated with damage, relocation or removal of private property caused by the City performing work in the public way.

Authority herein given and granted for a period of five (5) years from and after 04/21/2014.

Alderman _____

Brendan Reilly 42nd Ward

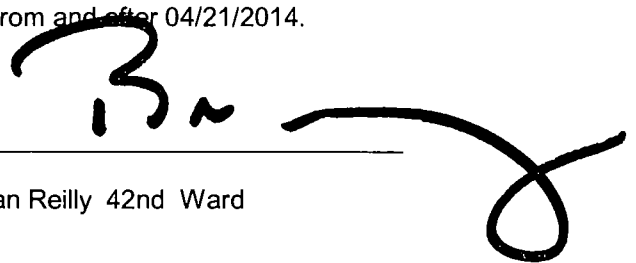
A large, stylized handwritten signature in black ink, appearing to be 'B. Reilly', is written over the signature line and extends to the right.

Handwritten scribbles or marks, possibly a signature or initials, located in the lower-left quadrant of the page.

HUGO'S BALCONIES PLAN

SCALE: 1/16" = 1'-0"

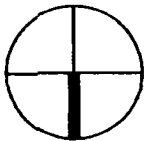

LEGEND

- EXISTING TREES TO REMAIN
- NEW TREE CRANES
- STREET SIGNS TO REMAIN
- STREET LIGHTS
- STREET LIGHTS TO REMAIN

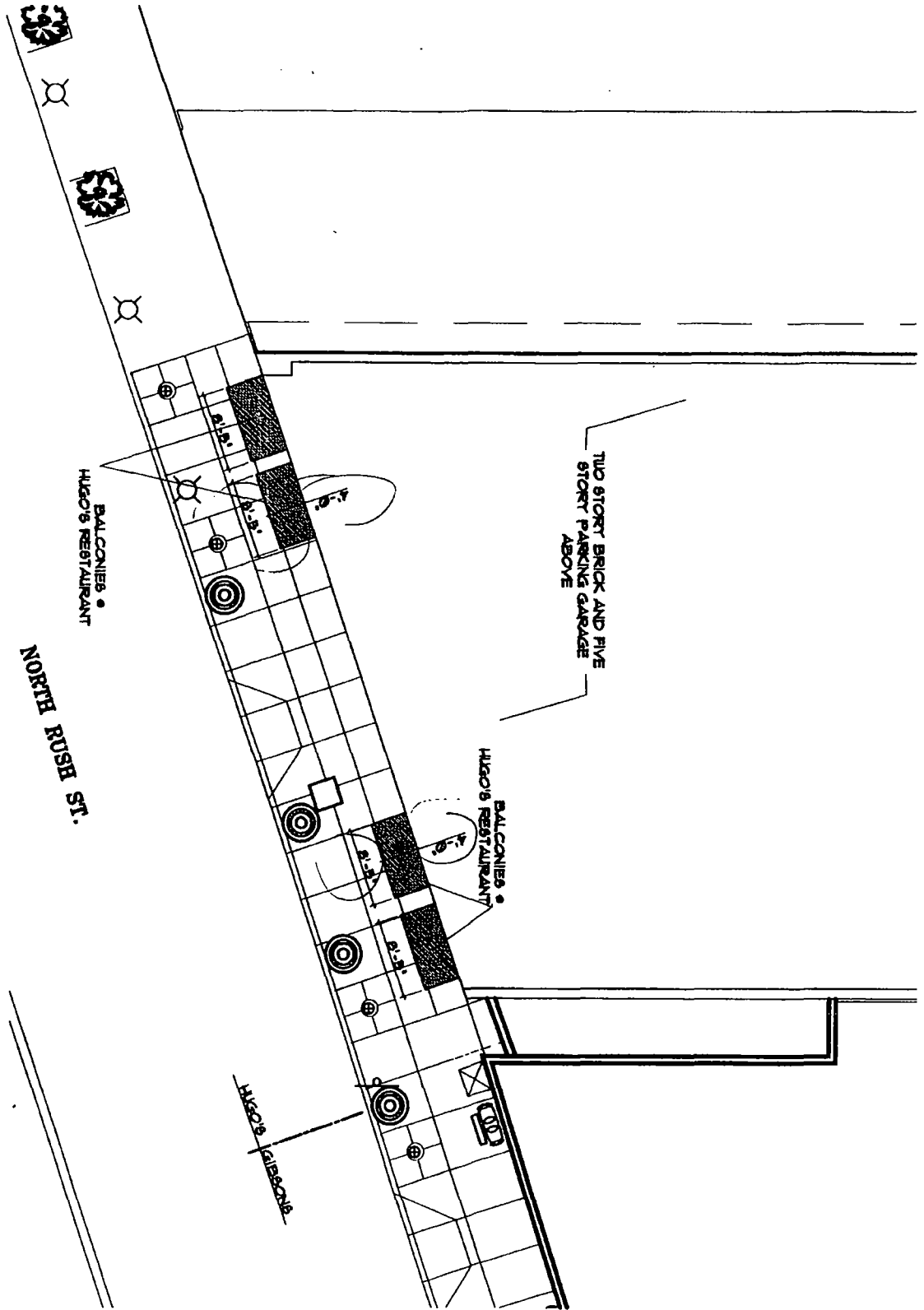

| | | |
|--|-------------------------------------|------------------------|
| Shapiro Associates Ltd ARCHITECTURAL SERVICES 1021 WEST ADAMS STREET CHICAGO, ILLINOIS 60607 312.421.6004 | PROJECT: HUGOS RESTAURANT | JOB NO: 0112 |
| | TITLE: BALCONIES PLAN | SK-040203 |
| DATE ISSUED: 04/02/03 | DATE REVISED: 04/02/03 | 1 OF 1 |



City of Chicago



O2014-4824

Office of the City Clerk

Document Tracking Sheet

| | |
|---------------------------------|---|
| Meeting Date: | 5/28/2014 |
| Sponsor(s): | Reilly (42) |
| Type: | Ordinance |
| Title: | Grant(s) of privilege in public way for Hyatt Place |
| Committee(s) Assignment: | Committee on Transportation and Public Way |

ORDINANCE
HYATT PLACE
Acct. No. 389795 - 1
Permit No. 1113080

Be It Ordained by the City Council of the City of Chicago:

SECTION 1. Permission and authority are hereby given and granted to HYATT PLACE, upon the terms and subject to the conditions of this ordinance to construct, install, maintain and use one (1) Door Swing(s) on the public right-of-way adjacent to its premises known as 28 N. Franklin St..

Said Door Swing(s) at N. Franklin Street measure(s):

One (1) at six point five (6.5) feet in length, and two point five eight (2.58) feet in width for a total of sixteen point seven seven (16.77) square feet.

The location of said privilege shall be as shown on prints kept on file with the Department of Business Affairs and Consumer Protection and the Office of the City Clerk.

Said privilege shall be constructed in accordance with plans and specifications approved by the Department of Transportation (Division of Project Development).

This grant of privilege in the public way shall be subject to the provisions of Section 10-28-015 and all other required provisions of the Municipal Code of Chicago.

The grantee shall pay to the City of Chicago as compensation for the privilege #1113080 herein granted the sum of seventy-five (\$75.00) per annum in advance.

A 25% penalty will be added for payments received after due date.

The permit holder agrees to hold the City of Chicago harmless for any damage, relocation or replacement costs associated with damage, relocation or removal of private property caused by the City performing work in the public way.

Authority herein given and granted for a period of five (5) years from and after Date of Passage.

Alderman _____

Brendan Reilly 42nd Ward

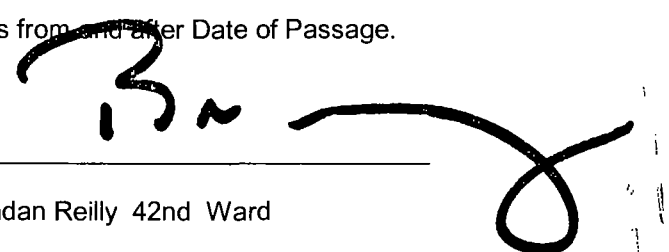
A large, stylized handwritten signature in black ink, appearing to read 'B. Reilly', is written over the signature line and extends to the right.

Handwritten scribble or signature, possibly containing the number '2'.

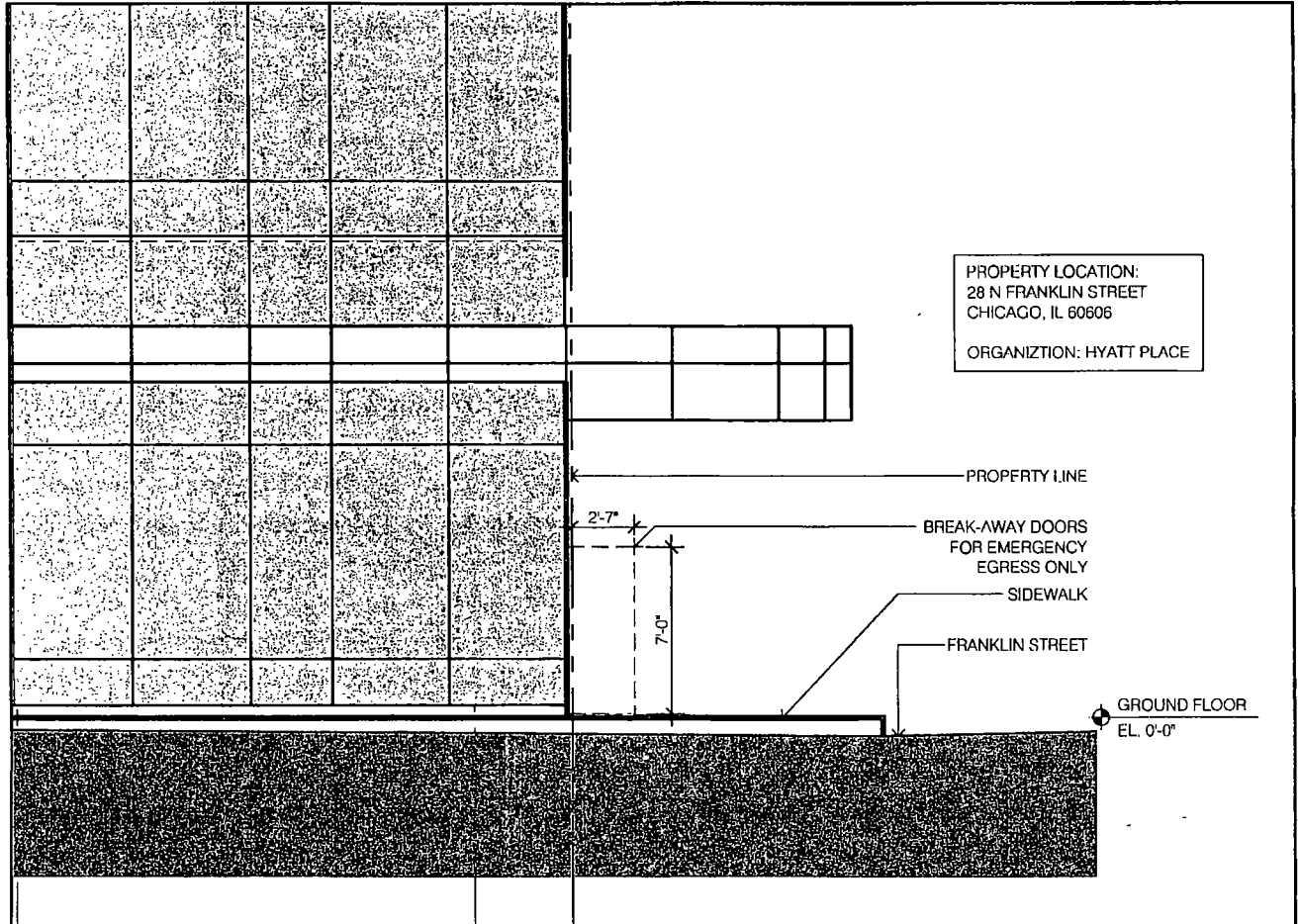

| | | | | | |
|---|---|---------------------------|---------------|-------------|-------------|
|  VOA ASSOCIATES, INC. Architecture/Planning/Interior Design 224 South Michigan Avenue #1400 Chicago, Illinois 60604 P. (312)554-1400 F. (312)554-1412 | HYATT PLACE 28 N FRANKLIN STREET, CHICAGO, IL 60606 | | SCALE | DRAWN BY | SHEET |
| | SOUTH ELEVATION PROPOSED BREAK-AWAY DOORS | | 3/16" = 1'-0" | YXL | |
| | | REVISION | DATE | CHECKED BY: | A-05 |
| | | APP TO USE THE PUBLIC ROW | 01 07 14 | RMB | |

Plot Date: 1/15/2014



City of Chicago



O2014-4825

Office of the City Clerk

Document Tracking Sheet

| | |
|---------------------------------|--|
| Meeting Date: | 5/28/2014 |
| Sponsor(s): | Reilly (42) |
| Type: | Ordinance |
| Title: | Grant(s) of privilege in public way for KHRG Allegro LLC |
| Committee(s) Assignment: | Committee on Transportation and Public Way |

ORDINANCE
KHRG ALLEGRO LLC
Acct. No. 314818 - 4
Permit No. 1112827

Be It Ordained by the City Council of the City of Chicago:

SECTION 1. Permission and authority are hereby given and granted to KHRG ALLEGRO LLC, upon the terms and subject to the conditions of this ordinance to maintain and use one (1) sign(s) projecting over the public right-of-way attached to its premises known as 161 W. Randolph St..

Said sign structure(s) measures as follows; along W. Randolph Street:
One (1) at four point nine two (4.92) feet in length, fifteen point three three (15.33) feet in height and ten point four two (10.42) feet above grade level.

The location of said privilege shall be as shown on prints kept on file with the Department of Business Affairs and Consumer Protection and the Office of the City Clerk.

Said privilege shall be constructed in accordance with plans and specifications approved by the Department of Transportation (Division of Project Development) and Zoning Department - Signs.

This grant of privilege in the public way shall be subject to the provisions of Section 10-28-015 and all other required provisions of the Municipal Code of Chicago.

The grantee shall pay to the City of Chicago as compensation for the privilege #1112827 herein granted the sum of three hundred (\$300.00) per annum in advance.

A 25% penalty will be added for payments received after due date.

The permit holder agrees to hold the City of Chicago harmless for any damage, relocation or replacement costs associated with damage, relocation or removal of private property caused by the City performing work in the public way.

Authority herein given and granted for a period of five (5) years from and after 04/22/2014.

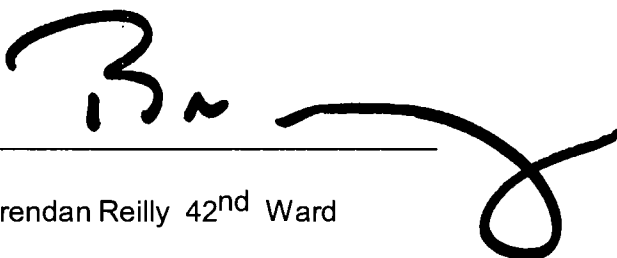
Alderman 
Brendan Reilly 42nd Ward

8-1-19

HOTEL ALLEGRO
171 WEST RANDOLPH STREET
CHICAGO, ILLINOIS

JANUARY 1, 2008

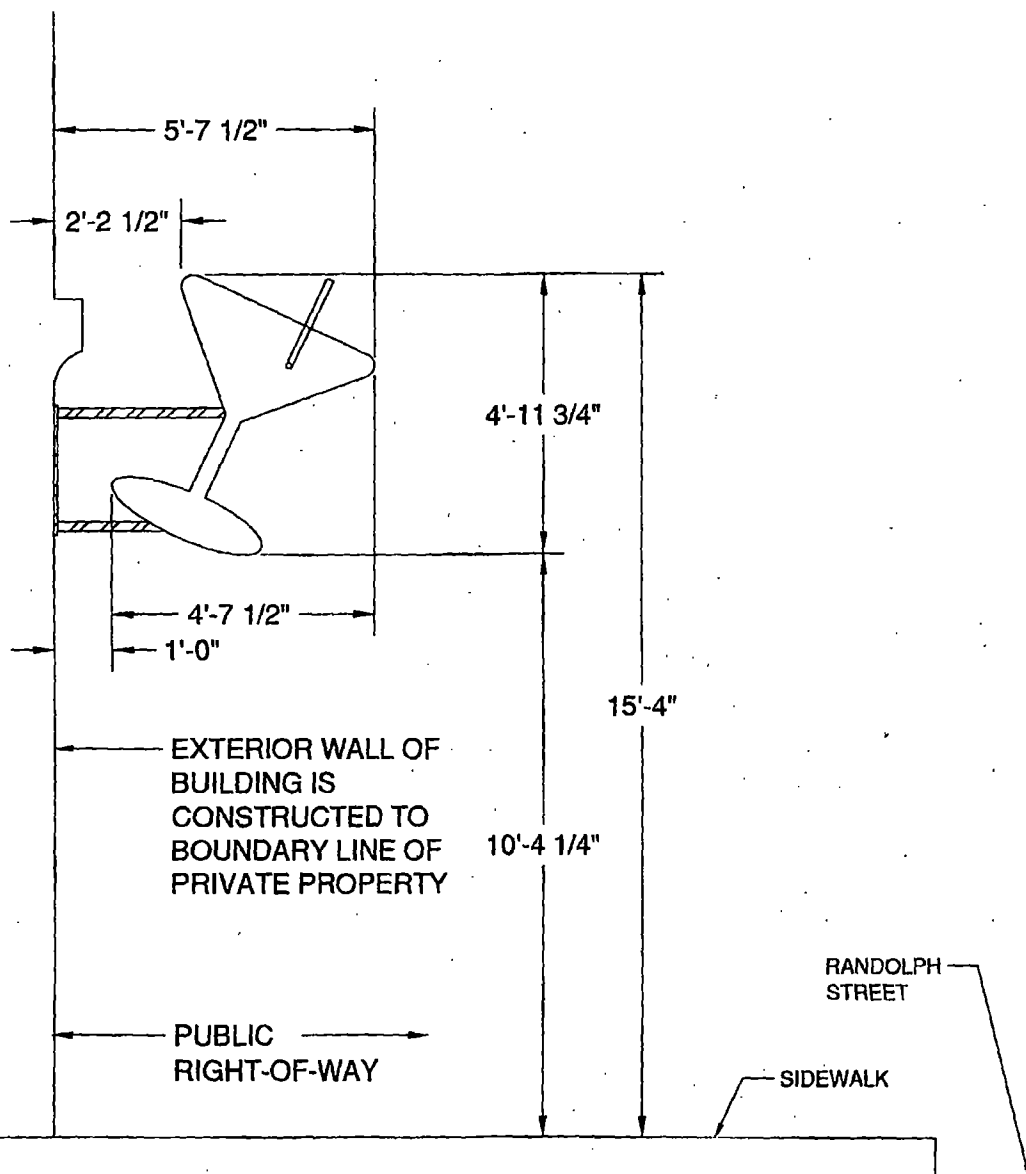

Exhibit 4-B

View looking west along Randolph Street
at
Wall Mounted sign above Entrance to
Encore Lounge
161 W. Randolph Street



City of Chicago



O2014-4826

Office of the City Clerk

Document Tracking Sheet

| | |
|---------------------------------|--|
| Meeting Date: | 5/28/2014 |
| Sponsor(s): | Reilly (42) |
| Type: | Ordinance |
| Title: | Grant(s) of privilege in public way for Macy's Retail Holdings, Inc. |
| Committee(s) Assignment: | Committee on Transportation and Public Way |

ORDINANCE
MACY'S RETAIL HOLDINGS, INC.
Acct. No. 284269 - 1
Permit No. 1111653

Be It Ordained by the City Council of the City of Chicago:

SECTION 1. Permission and authority are hereby given and granted to MACY'S RETAIL HOLDINGS, INC., upon the terms and subject to the conditions of this ordinance to maintain and use, as now constructed, an Ornamental Entrance(s) on the public right-of-way adjacent to its premises known as 111 N. State St.. Existing ornamental entrance supported by four (4) columns in the sidewalk space on the east side of North State Street between East Washington Street and East Randolph Street, the bases of each supporting columns not to exceed six (6) feet six (6) inches by ninety-four (94) feet ten (10) inches adjacent to its premises known as 111 North State Street.

The location of said privilege shall be as shown on prints kept on file with the Department of Business Affairs and Consumer Protection and the Office of the City Clerk.

Said privilege shall be constructed in accordance with plans and specifications approved by the Department of Planning and Development and Department of Transportation (Division of Project Development).

This grant of privilege in the public way shall be subject to the provisions of Section 10-28-015 and all other required provisions of the Municipal Code of Chicago.

The grantee shall pay to the City of Chicago as compensation for the privilege #1111653 herein granted the sum of one thousand five hundred fifty-six (\$1,556.00) per annum in advance.

A 25% penalty will be added for payments received after due date.

The permit holder agrees to hold the City of Chicago harmless for any damage, relocation or replacement costs associated with damage, relocation or removal of private property caused by the City performing work in the public way.

Authority herein given and granted for a period of five (5) years from and after 01/30/2014.

Alderman _____

Brendan Reilly 42nd Ward

| TITLE SHEET | | | SCALE |
|-------------|------------|----------|---------|
| NO. | DATE | DATE | 1/27/73 |
| SCALE | DRAWN BY | DATE | JOB NO. |
| 1/8"=1'-0" | J. SZALOWY | 12-11-73 | 3307 |

Marshall Field & Company
ARCHITECTURAL PLANNING DEPARTMENT

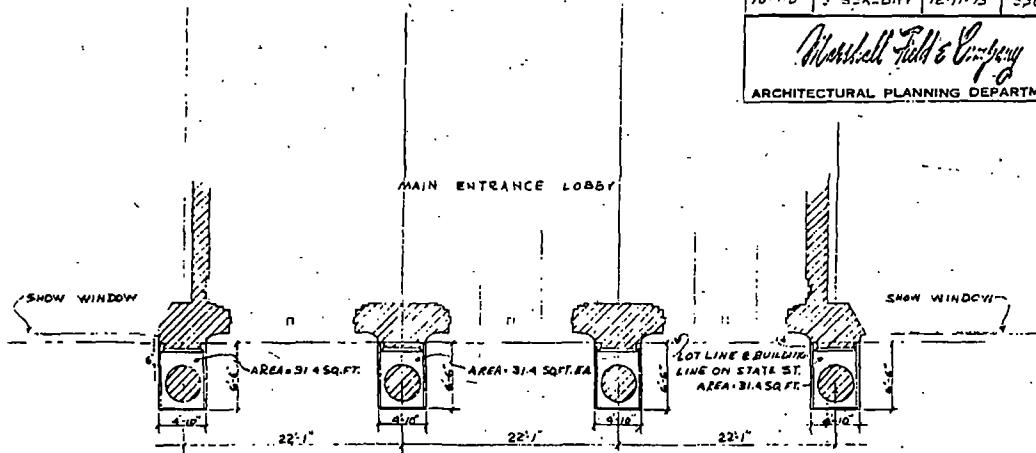

PLAN OF MAIN ENTRANCE ON STATE STREET

111 N. STATE ST.

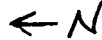



City of Chicago



O2014-4827

Office of the City Clerk

Document Tracking Sheet

| | |
|---------------------------------|--|
| Meeting Date: | 5/28/2014 |
| Sponsor(s): | Reilly (42) |
| Type: | Ordinance |
| Title: | Grant(s) of privilege in public way for Madison LaSalle Partners LLC |
| Committee(s) Assignment: | Committee on Transportation and Public Way |

ORDINANCE
MADISON LA SALLE PARTNERS, LLC
Acct. No. 342222 - 1
Permit No. 1112264

Be It Ordained by the City Council of the City of Chicago:

SECTION 1. Permission and authority are hereby given and granted to MADISON LA SALLE PARTNERS, LLC, upon the terms and subject to the conditions of this ordinance to maintain and use, as now constructed, three (3) Cornice(s) projecting over the public right-of-way adjacent to its premises known as 10 S. La Salle St..

Said Cornice(s) at S. La Salle measure(s):

One (1) at one hundred ninety-four point seven five (194.75) feet in length, and two point three three (2.33) feet in width for a total of four hundred fifty-three point seven seven (453.77) square feet. Existing cornice encroaches over the public way at the third (3rd) floor.

Said Cornice(s) at W. Madison measure(s):

One (1) at one hundred sixteen (116) feet in length, and two point three three (2.33) feet in width for a total of two hundred seventy point two eight (270.28) square feet. Existing cornice encroaches over the public way at the third (3rd) floor.

Said Cornice(s) at Arcade Pl measure(s):

One (1) at twenty-seven point three three (27.33) feet in length, and two point three three (2.33) feet in width for a total of sixty-three point six eight (63.68) square feet. Existing cornice encroaches over the public way at the third (3rd) floor.

The location of said privilege shall be as shown on prints kept on file with the Department of Business Affairs and Consumer Protection and the Office of the City Clerk.

Said privilege shall be constructed in accordance with plans and specifications approved by the Department of Transportation (Division of Project Development).

This grant of privilege in the public way shall be subject to the provisions of Section 10-28-015 and all other required provisions of the Municipal Code of Chicago.

The grantee shall pay to the City of Chicago as compensation for the privilege #1112264 herein granted the sum of one thousand eight hundred two (\$1,802.00) per annum in advance.

A 25% penalty will be added for payments received after due date.

The permit holder agrees to hold the City of Chicago harmless for any damage, relocation or replacement costs associated with damage, relocation or removal of private property caused by the City performing work in the public way.

Authority herein given and granted for a period of five (5) years from and after 03/02/2014.

Alderman _____

Brendan Reilly 42nd Ward

Handwritten scribbles and marks at the bottom of the page, possibly including a signature or initials.

100 WEST MADISON STREET
CHICAGO, ILLINOIS 60601
NOTE: SEE MAP SHEET NO. 8711005
TELEPHONE: 812-710-8800

CHICAGO GUARANTEE SURVEY COMPANY

UTILITY PLAT

10 S. LASALLE ST.

PROJECT: 2 MADISON
PROJECT: 2 MADISON
PROJECT: 2 MADISON
PROJECT: 2 MADISON

FOR SURVEY INFORMATION REFER TO OUR ORDER NO. 8711005



SCALE 1" = 15'

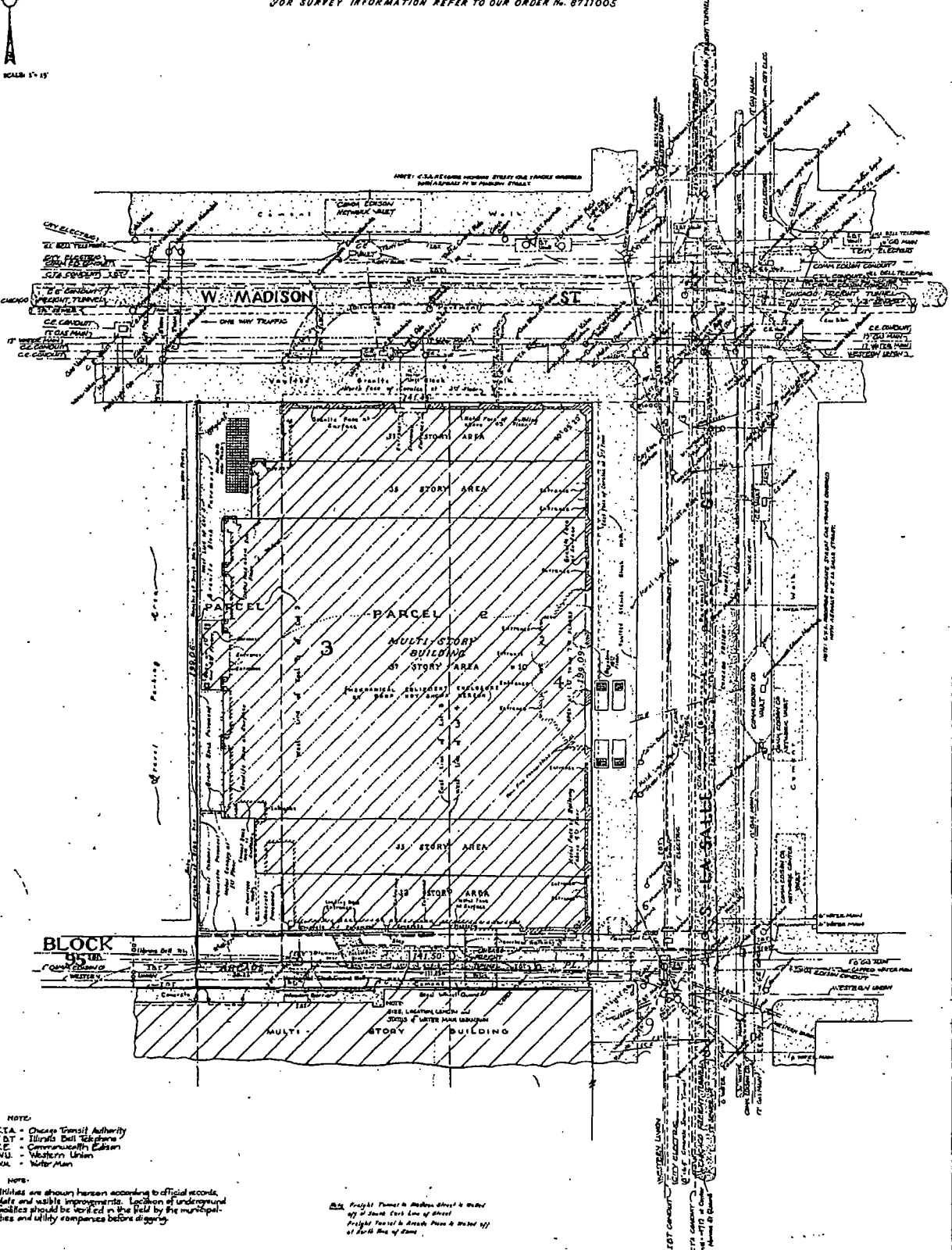

NOTE:
CIA - Chicago Transit Authority
IDT - Illinois Bell Telephone
CE - Commonwealth Edison
WU - Western Union
WM - Water Main

NOTE:
Utilities are shown hereon according to official records, date and visible improvements. Location of underground facilities should be verified in the field by the municipalities and utility companies before digging.

See Freight Tunnel & Madison Street & Water off of South East Line of Street
Freight Tunnel & South Pass & Water off of North Line of Same



Drawn as shown to field and details
Order No. 8711005-A
Order by: FIDRAM (U.S.) INCORPORATED

FOR BUILDING LINES AND OTHER RESTRICTIONS NOT SHOWN HEREON REFER TO YOUR ABSTRACT, DEED, CONTRACT AND LOCAL BUILDING REGULATIONS

Revised Jan. 7, 1988
Revised Dec. 22, 1987



CHICAGO GUARANTEE SURVEY COMPANY
100 W. Madison St. Chicago, Illinois, 60601
Date: Dec 11, A.M. 1987

By: *K.H. J. [Signature]*



City of Chicago



O2014-4828

Office of the City Clerk

Document Tracking Sheet

| | |
|---------------------------------|---|
| Meeting Date: | 5/28/2014 |
| Sponsor(s): | Reilly (42) |
| Type: | Ordinance |
| Title: | Grant(s) of privilege in public way for Maggiano's Little Italy - light fixtures |
| Committee(s) Assignment: | Committee on Transportation and Public Way |

ORDINANCE
MAGGIANO'S LITTLE ITALY
Acct. No. 85312 - 2
Permit No. 1112887

Be It Ordained by the City Council of the City of Chicago:

SECTION 1. Permission and authority are hereby given and granted to MAGGIANO'S LITTLE ITALY, upon the terms and subject to the conditions of this ordinance to maintain and use, as now constructed, seven (7) Light Fixture(s) projecting over the public right-of-way adjacent to its premises known as 516 N. Clark St..

Said Light Fixture(s) at N Clark St (Flood) measure(s):

Four (4) at point six seven (.67) feet in length, point five (.5) feet in width and fifteen (15) feet above grade level.

Said Light Fixture(s) at W Grand Ave (Flood) measure(s):

Two (2) at point six seven (.67) feet in length, point five (.5) feet in width and thirty (30) feet above grade level.

Said Light Fixture(s) at W Grand Ave (Goose Neck) measure(s):

One (1) at one (1) foot in length, three (3) feet in width and seven point five eight (7.58) feet above grade level.

The location of said privilege shall be as shown on prints kept on file with the Department of Business Affairs and Consumer Protection and the Office of the City Clerk.

Said privilege shall be constructed in accordance with plans and specifications approved by the Department of Transportation (Division of Project Development).

This grant of privilege in the public way shall be subject to the provisions of Section 10-28-015 and all other required provisions of the Municipal Code of Chicago.

The grantee shall pay to the City of Chicago as compensation for the privilege #1112887 herein granted the sum of one hundred five (\$105.00) per annum in advance.

A 25% penalty will be added for payments received after due date.

The permit holder agrees to hold the City of Chicago harmless for any damage, relocation or replacement costs associated with damage, relocation or removal of private property caused by the City performing work in the public way.

Authority herein given and granted for a period of five (5) years from and after 01/13/2014.

Alderman _____

Brendan Reilly 42nd Ward

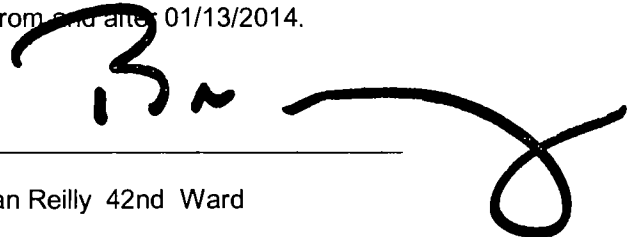

1. The first part of the document is a list of names and titles, including "The Hon. Mr. Justice" and "The Hon. Mr. Justice".

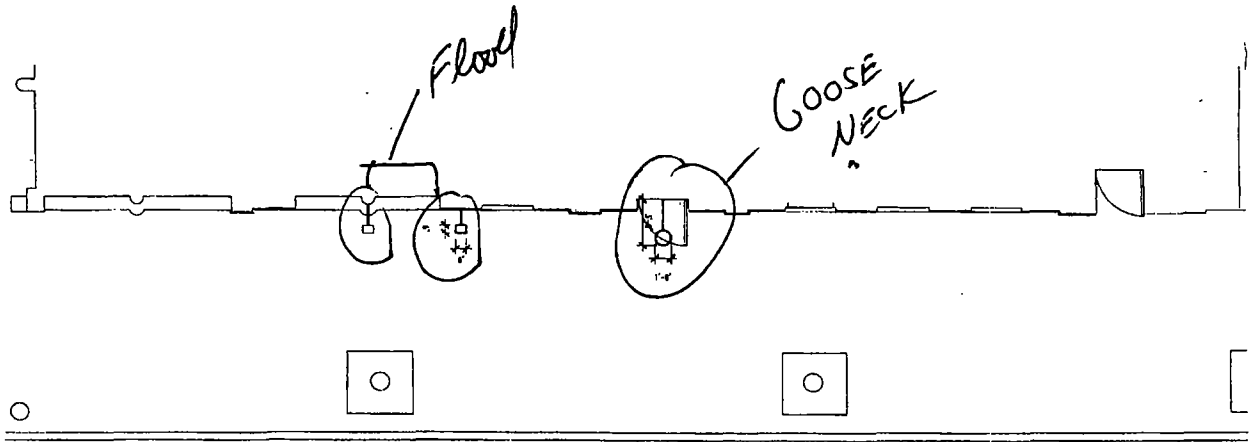

W. GRAND AVE.

LIGHTS ON GRAND
1/8" = 1'



#47 Clark & Grand
Permit Renewal

04.10.2014
Page 5



BRINKER
INTERNATIONAL



City of Chicago



O2014-4831

Office of the City Clerk

Document Tracking Sheet

| | |
|---------------------------------|---|
| Meeting Date: | 5/28/2014 |
| Sponsor(s): | Reilly (42) |
| Type: | Ordinance |
| Title: | Grant(s) of privilege in public way for Maggiano's Little Italy - park bench |
| Committee(s) Assignment: | Committee on Transportation and Public Way |

ORDINANCE
MAGGIANO'S LITTLE ITALY
Acct. No. 85312 - 2
Permit No. 1112813

Be It Ordained by the City Council of the City of Chicago:

SECTION 1. Permission and authority are hereby given and granted to MAGGIANO'S LITTLE ITALY, upon the terms and subject to the conditions of this ordinance to maintain and use, as now constructed, one (1) Park bench(s) on the public right-of-way adjacent to its premises known as 516 N. Clark St..

Said Park bench(s) at N Clark St measure(s):

One (1) at four (4) feet in length, and two (2) feet in width for a total of eight (8) square feet.

The location of said privilege shall be as shown on prints kept on file with the Department of Business Affairs and Consumer Protection and the Office of the City Clerk.

Said privilege shall be constructed in accordance with plans and specifications approved by the Department of Transportation (Division of Project Development).

This grant of privilege in the public way shall be subject to the provisions of Section 10-28-015 and all other required provisions of the Municipal Code of Chicago.

The grantee shall pay to the City of Chicago as compensation for the privilege #1112813 herein granted the sum of seventy-five (\$75.00) per annum in advance.

A 25% penalty will be added for payments received after due date.

The permit holder agrees to hold the City of Chicago harmless for any damage, relocation or replacement costs associated with damage, relocation or removal of private property caused by the City performing work in the public way.

Authority herein given and granted for a period of five (5) years from and after 01/13/2014.

Alderman _____

Brendan Reilly 42nd Ward

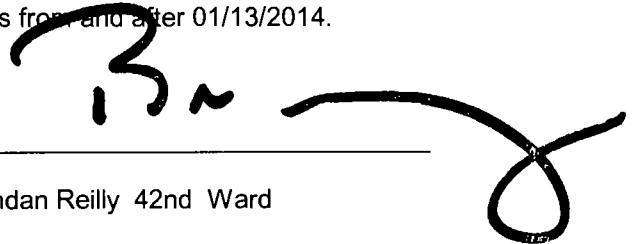
A large, stylized handwritten signature in black ink, appearing to read 'B. Reilly', is written over the signature line and extends to the right.

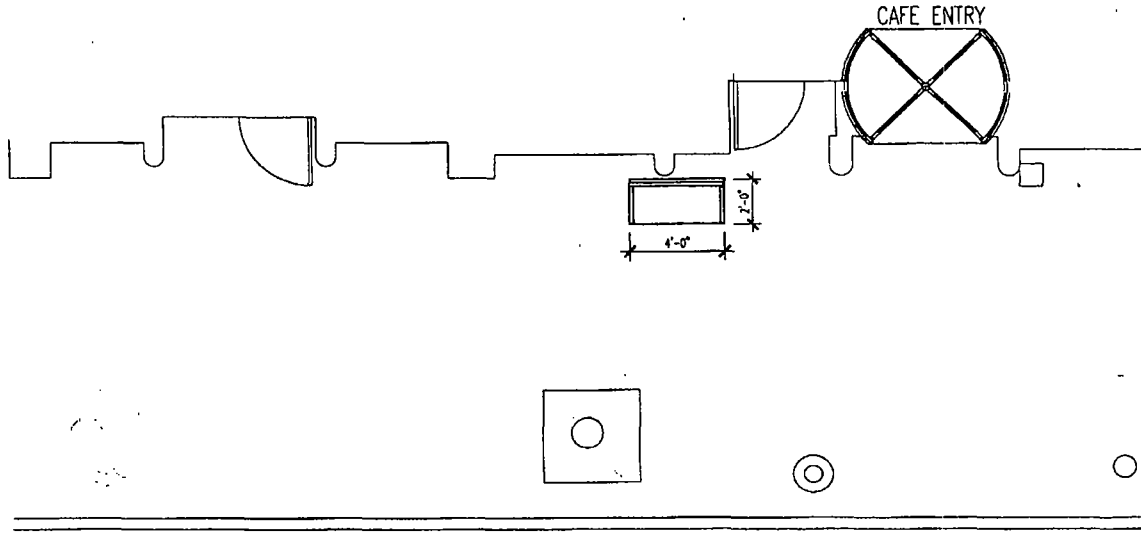

BENCH ON CLARK
 3/16" = 1'



#47 Clark & Grand
 Permit Renewal

04.10.2014
 Page 7



BRINKER
 INTERNATIONAL



City of Chicago



O2014-4833

Office of the City Clerk

Document Tracking Sheet

| | |
|---------------------------------|--|
| Meeting Date: | 5/28/2014 |
| Sponsor(s): | Reilly (42) |
| Type: | Ordinance |
| Title: | Grant(s) of privilege in public way for Maggiano's Little Italy - sign |
| Committee(s) Assignment: | Committee on Transportation and Public Way |

ORDINANCE
MAGGIANO'S LITTLE ITALY
Acct. No. 85312 - 2
Permit No. 1112809

Be It Ordained by the City Council of the City of Chicago:

SECTION 1. Permission and authority are hereby given and granted to MAGGIANO'S LITTLE ITALY, upon the terms and subject to the conditions of this ordinance to maintain and use one (1) sign(s) projecting over the public right-of-way attached to its premises known as 516 N. Clark St..

Said sign structure(s) measures as follows; along N CLARK ST:

One (1) at three point four two (3.42) feet in length, ten point five (10.5) feet in height and ten point three three (10.33) feet above grade level.

The location of said privilege shall be as shown on prints kept on file with the Department of Business Affairs and Consumer Protection and the Office of the City Clerk.

Said privilege shall be constructed in accordance with plans and specifications approved by the Department of Transportation (Division of Project Development) and Zoning Department - Signs.

This grant of privilege in the public way shall be subject to the provisions of Section 10-28-015 and all other required provisions of the Municipal Code of Chicago.

The grantee shall pay to the City of Chicago as compensation for the privilege #1112809 herein granted the sum of three hundred (\$300.00) per annum in advance.

A 25% penalty will be added for payments received after due date.

The permit holder agrees to hold the City of Chicago harmless for any damage, relocation or replacement costs associated with damage, relocation or removal of private property caused by the City performing work in the public way.

Authority herein given and granted for a period of five (5) years from and after 01/13/2014.

Alderman _____

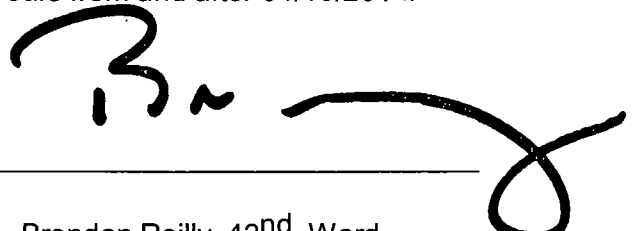

Brendan Reilly 42nd Ward

Handwritten scribbles and faint markings, possibly including a circled '0' and some illegible characters.

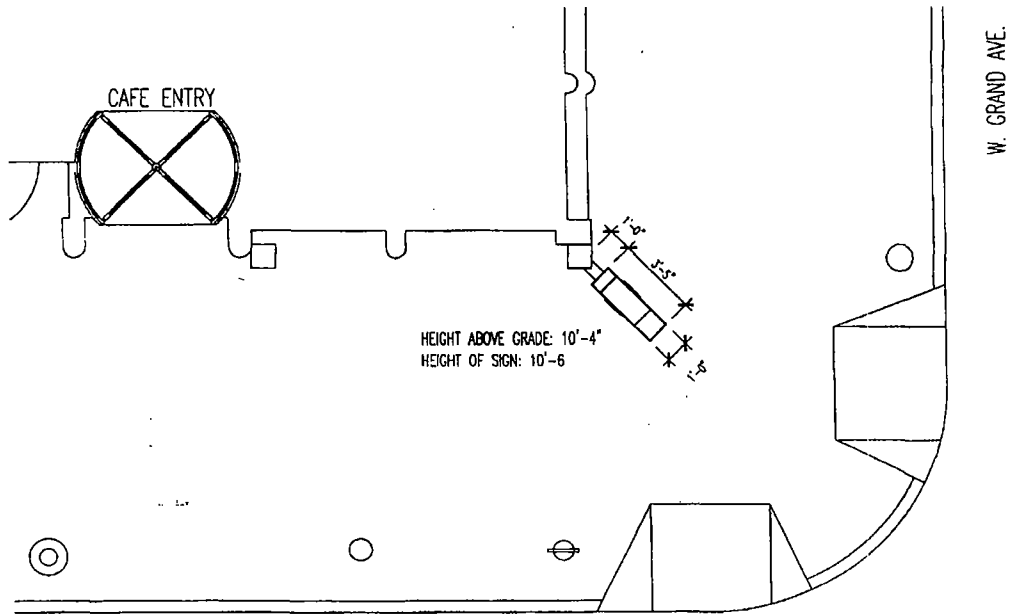

N. CLARK ST.

SIGN ON CORNER
3/16" = 1'



#47 Clark & Grand
Permit Renewal

04.10.2014
Page 6



BRINKER
INTERNATIONAL



City of Chicago



O2014-4836

Office of the City Clerk

Document Tracking Sheet

| | |
|---------------------------------|---|
| Meeting Date: | 5/28/2014 |
| Sponsor(s): | Reilly (42) |
| Type: | Ordinance |
| Title: | Grant(s) of privilege in public way for MB Financial Bank |
| Committee(s) Assignment: | Committee on Transportation and Public Way |

ORDINANCE
MB FINANCIAL BANK
Acct. No. 248808 - 48
Permit No. 1113069

Be It Ordained by the City Council of the City of Chicago:

SECTION 1. Permission and authority are hereby given and granted to MB FINANCIAL BANK, upon the terms and subject to the conditions of this ordinance to maintain and use two (2) sign(s) projecting over the public right-of-way attached to its premises known as 33 W. Huron St..

Said sign structure(s) measures as follows; along N. Dearborn Street:

One (1) at five (5) feet in length, five (5) feet in height and twelve (12) feet above grade level.

One (1) at nine point five (9.5) feet in length, two (2) feet in height and twelve (12) feet above grade level.

The location of said privilege shall be as shown on prints kept on file with the Department of Business Affairs and Consumer Protection and the Office of the City Clerk.

Said privilege shall be constructed in accordance with plans and specifications approved by the Department of Transportation (Division of Project Development) and Zoning Department - Signs.

This grant of privilege in the public way shall be subject to the provisions of Section 10-28-015 and all other required provisions of the Municipal Code of Chicago.

The grantee shall pay to the City of Chicago as compensation for the privilege #1113069 herein granted the sum of four hundred (\$400.00) per annum in advance.

A 25% penalty will be added for payments received after due date.

The permit holder agrees to hold the City of Chicago harmless for any damage, relocation or replacement costs associated with damage, relocation or removal of private property caused by the City performing work in the public way.

Authority herein given and granted for a period of five (5) years from and after 11/19/2013.

Alderman _____

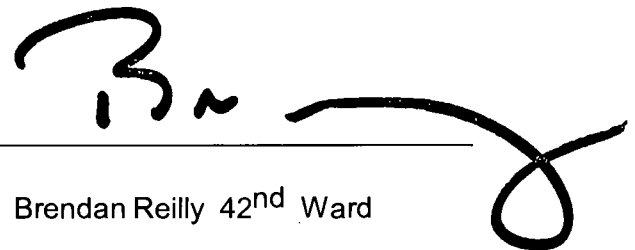
A large, stylized handwritten signature in black ink, appearing to read 'B. Reilly', is written over a horizontal line. The signature is fluid and cursive, with a large loop at the end.

Brendan Reilly 42nd Ward

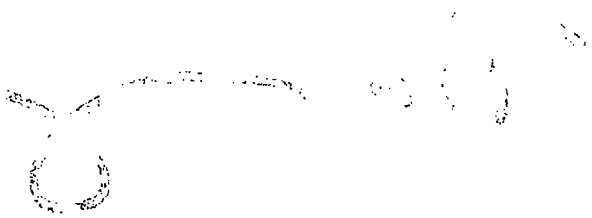

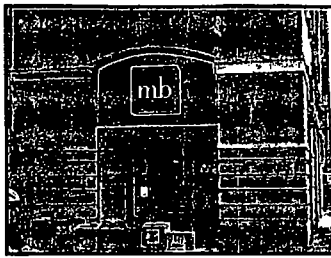
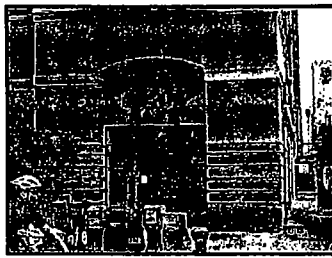

Existing Sign # 1
 Illum Non Illum S/F D/F
 H NA W 7'3" D NA OAH NA
 Note: 1 7" Reverse Channel Illuminated Letters

Proposed Sign # 1
 Note: BLACK BACKGROUND

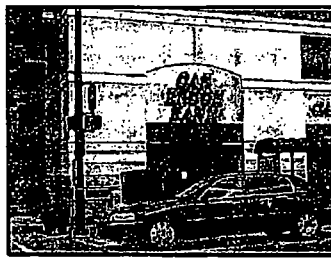

Existing Sign # 2
 Illum Non Illum S/F D/F
 H NA W 7'3" D NA OAH NA
 Note: 1 7" Reverse Channel Illuminated Letters

Proposed Sign # 2
 Note: BLACK BACKGROUND

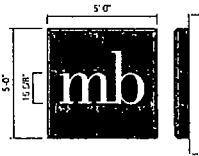

W-25 S.F. ILLUMINATED WALL SIGN
 SIGN #1
 QTY: 1
 SCALE: 1/4" = 1'-0"

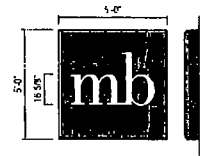

W-25 S.F. ILLUMINATED WALL SIGN
 SIGN #2
 QTY: 1
 SCALE: 1/4" = 1'-0"



LOCATION 938-006
 33 W Huron St
 Chicago, IL

FILE 938-008 Chicago ckt
 DATE 08/11/06
 DRAWN KP

PG# 3 of 9
 SCALE As Noted
 DIRECTOR

REVISED 09/06/06 KP 09/18/06 PMF

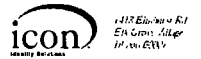



City of Chicago



O2014-4838

Office of the City Clerk

Document Tracking Sheet

| | |
|---------------------------------|---|
| Meeting Date: | 5/28/2014 |
| Sponsor(s): | Reilly (42) |
| Type: | Ordinance |
| Title: | Grant(s) of privilege in public way for Millennium Trolley Tours LLC |
| Committee(s) Assignment: | Committee on Transportation and Public Way |

ORDINANCE

Millennium Trolley Tours LLC

Acct. No. 383100 - 5

Permit No. 1111767

Be It Ordained by the City Council of the City of Chicago:

SECTION 1. Permission and authority are hereby given and granted to Millennium Trolley Tours LLC, upon the terms and subject to the conditions of this ordinance to construct, install, maintain and use one (1) Booth(s) on the public right-of-way adjacent to its premises known as 30 N. Michigan Ave..

Said Booth(s) at N. Michigan Avenue measure(s):

One (1) at two (2) feet in length, and one point five (1.5) foot in width for a total of three (3) square feet. Booth shall be approximately thirty-three (33) inches in height.

The location of said privilege shall be as shown on prints kept on file with the Department of Business Affairs and Consumer Protection and the Office of the City Clerk.

Said privilege shall be constructed in accordance with plans and specifications approved by the Department of Transportation (Division of Project Development).

This grant of privilege in the public way shall be subject to the provisions of Section 10-28-015 and all other required provisions of the Municipal Code of Chicago.

The grantee shall pay to the City of Chicago as compensation for the privilege #1111767 herein granted the sum of four hundred (\$400.00) per annum in advance.

A 25% penalty will be added for payments received after due date.

The permit holder agrees to hold the City of Chicago harmless for any damage, relocation or replacement costs associated with damage, relocation or removal of private property caused by the City performing work in the public way.

Authority herein given and granted for a period of five (5) years from and after Date of Passage.

Alderman _____

Brendan Reilly 42nd Ward

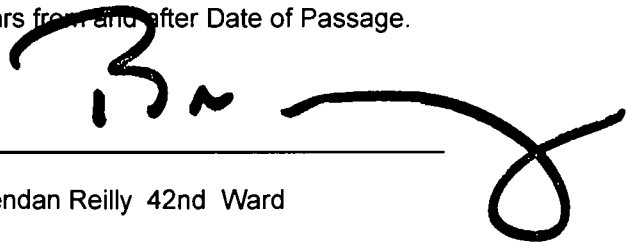
A large, stylized handwritten signature in black ink, appearing to read 'B. Reilly', is written over the signature line and extends to the right.

Handwritten scribbles and marks, possibly including the number '10' and some illegible characters.

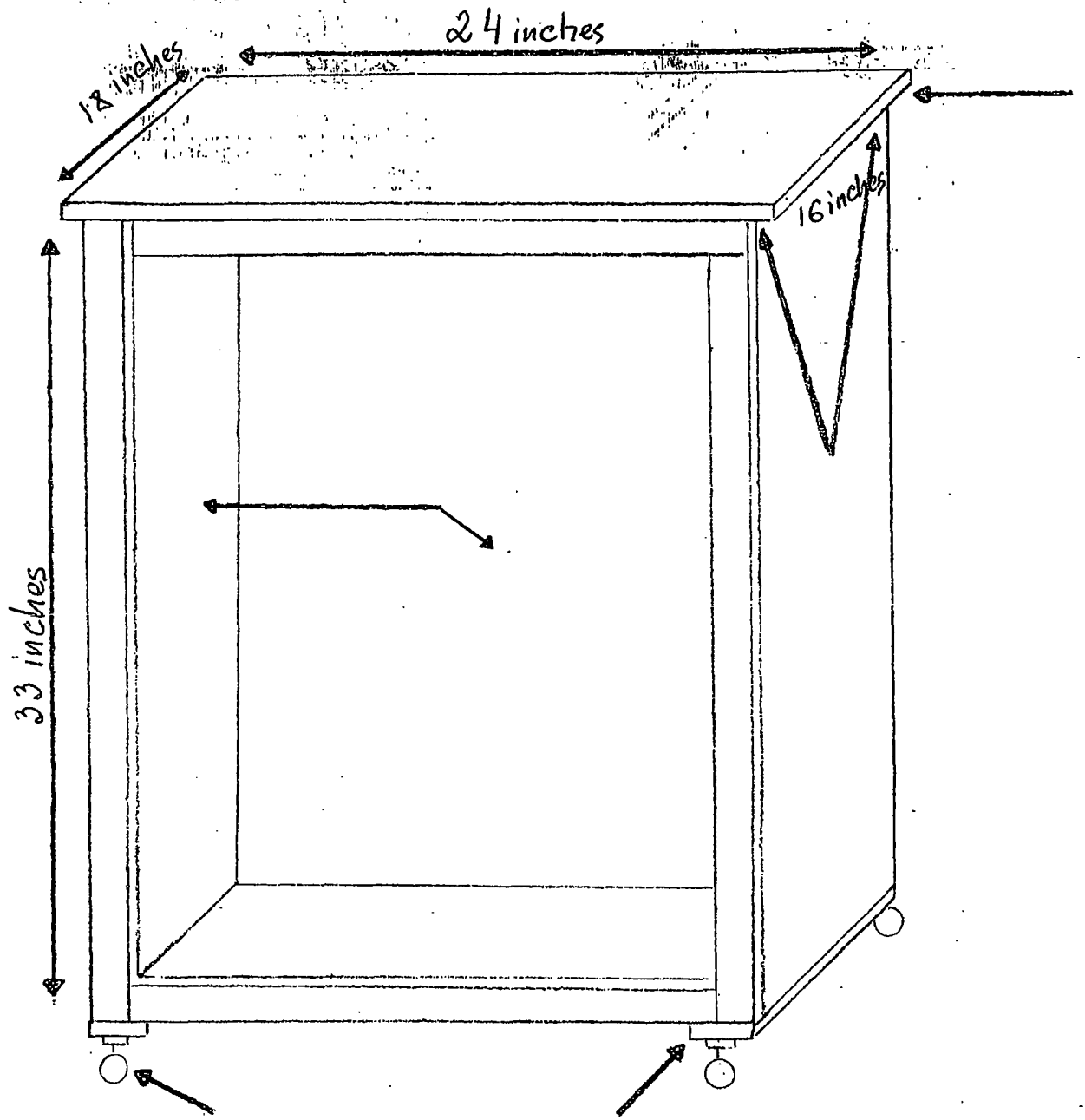



City of Chicago



O2014-4839

Office of the City Clerk

Document Tracking Sheet

| | |
|---------------------------------|--|
| Meeting Date: | 5/28/2014 |
| Sponsor(s): | Reilly (42) |
| Type: | Ordinance |
| Title: | Grant(s) of privilege in public way for Northwestern University/Chicago Campus - Privilege No. 1112817 |
| Committee(s) Assignment: | Committee on Transportation and Public Way |

ORDINANCE

Optima Inc.

Acct. No. 360205 - 2

Permit No. 1112817

Be It Ordained by the City Council of the City of Chicago:

SECTION 1. Permission and authority are hereby given and granted to Optima Inc., upon the terms and subject to the conditions of this ordinance to maintain and use, as now constructed, seventeen (17) Caisson(s) under the public right-of-way adjacent to its premises known as 214-236 E. Illinois St..

Said Caisson(s) at E. Grand Avenue measure(s):

One (1) at seventy-four point five six (74.56) feet in length, and twelve (12) feet in width for a total of eight hundred ninety-four point seven two (894.72) square feet. Existing caisson is approximately ninety (90) feet in depth.

Two (2) at seventy-four (74) feet in length, and eight (8) feet in width for a total of one thousand one hundred eighty-four (1184) square feet. Existing caissons are approximately ninety (90) feet in depth.

One (1) at sixty-nine point one seven (69.17) feet in length, and eight (8) feet in width for a total of five hundred fifty-three point three six (553.36) square feet. Existing caisson is approximately ninety (90) feet in depth.

One (1) at seventy-five point five (75.5) feet in length, and eight (8) feet in width for a total of six hundred four (604) square feet. Existing caisson is approximately ninety-one (91) feet in depth.

One (1) at seventy-four point one three (74.13) feet in length, and eight (8) feet in width for a total of five hundred ninety-three point zero four (593.04) square feet. Existing caisson is approximately ninety (90) in depth.

One (1) at seventy-four point five eight (74.58) feet in length, and eight (8) feet in width for a total of five hundred ninety-six point six four (596.64) square feet. Existing caisson is approximately ninety (90) feet in depth.

One (1) at seventy-four point nine one (74.91) feet in length, and eight (8) feet in width for a total of five hundred ninety-nine point two eight (599.28) square feet. Existing caisson is approximately ninety (90) feet in depth.

One (1) at seventy-five point two five (75.25) feet in length, and ten (10) feet in width for a total of seven hundred fifty-two point five (752.5) square feet. Existing caisson is approximately ninety-one (91) feet in depth.

Said Caisson(s) at E. Illinois Street measure(s):

One (1) at ninety point two two (90.22) feet in length, and twelve (12) feet in width for a total of one thousand eighty-two point six four (1082.64) square feet. Existing caisson is approximately ninety-three (93) feet in depth.

One (1) at ninety-one point three three (91.33) feet in length, and twelve (12) feet in width for a total of one thousand ninety-five point nine six (1095.96) square feet. Existing caisson is approximately ninety-four (94) feet in depth.

One (1) at ninety point three three (90.33) feet in length, and twelve (12) feet in width for a total of one thousand eighty-three point nine six (1083.96) square feet. Existing caisson is approximately ninety-three (93) feet in depth.

One (1) at eighty-eight point nine two (88.92) feet in length, and thirteen (13) feet in width for a total of one thousand one hundred fifty-five point nine six (1155.96) square feet. Existing caisson is approximately ninety-four (94) feet in depth.

One (1) at eighty-three point five (83.5) feet in length, and thirteen (13) feet in width for a total of one thousand eighty-five point five (1085.5) square feet. Existing caisson is approximately ninety-four (94) feet in depth.

One (1) at eighty-one point one seven (81.17) feet in length, and thirteen (13) feet in width for a total of one thousand fifty-five point two one (1055.21) square feet. Existing caisson is approximately ninety-two (92) feet in depth.

One (1) at eighty-nine (89) feet in length, and thirteen (13) feet in width for a total of one thousand one hundred fifty-seven (1157) square feet. Existing caisson is approximately ninety-two (92) feet in depth..

One (1) at eighty-six point five (86.5) feet in length, and sixteen (16) feet in width for a total of one thousand three hundred eighty-four (1384) square feet. Existing caisson is approximately ninety-two (92) feet in depth.

The location of said privilege shall be as shown on prints kept on file with the Department of Business Affairs and Consumer Protection and the Office of the City Clerk.

Said privilege shall be constructed in accordance with plans and specifications approved by the Department of Planning and Development and Department of Transportation (Office of Underground Coordination).

This grant of privilege in the public way shall be subject to the provisions of Section 10-28-015 and all other required provisions of the Municipal Code of Chicago.

The grantee shall pay to the City of Chicago as compensation for the privilege #1112817 herein granted the sum of nine thousand five hundred twenty-two (\$9,522.00) per annum in advance.

A 25% penalty will be added for payments received after due date.

The permit holder agrees to hold the City of Chicago harmless for any damage, relocation or replacement costs associated with damage, relocation or removal of private property caused by the City performing work in the public way.

Authority herein given and granted for a period of five (5) years from and after Date of Passage.

Alderman _____

Brendan Reilly 42nd Ward

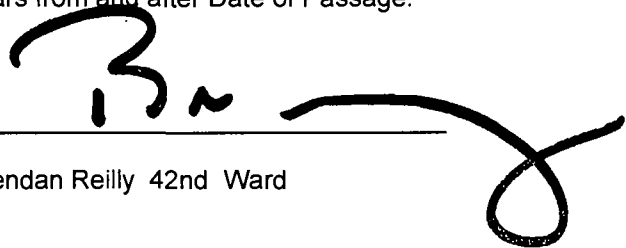
A large, stylized handwritten signature in black ink, appearing to read 'B. Reilly', is written over a horizontal line. The signature is fluid and cursive, with a large loop at the end.

Handwritten scribbles and faint markings, possibly including the number '107'.

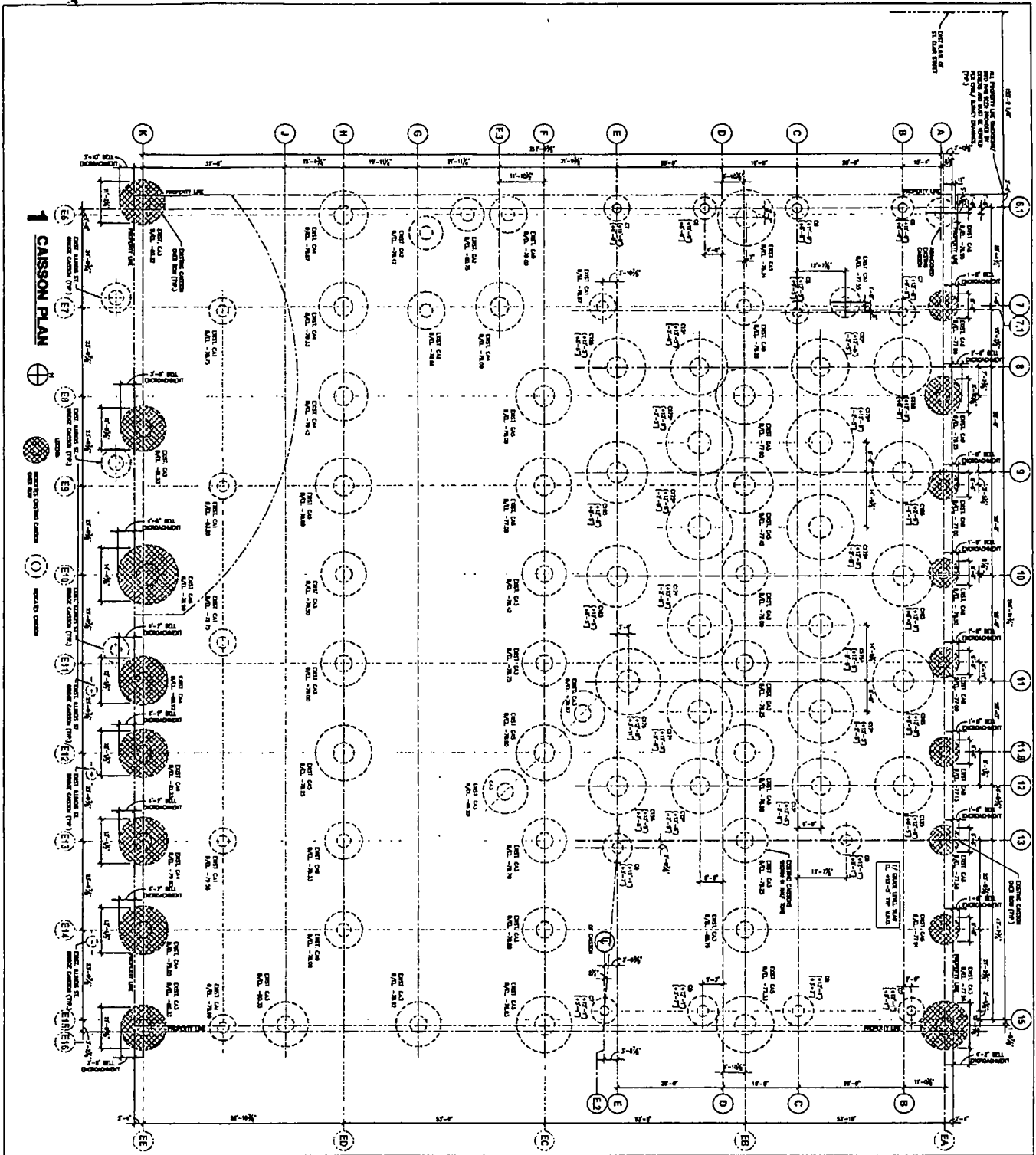

| | | | |
|---|-------|---|---------------|
| <h1>CSA</h1> <p>CS Associates, INC. 4532 West 103rd Street, Oak Lawn, IL 60453 Phn: (708) 422-5306 Fax: (708)422-3982</p> | | Project | Drawing Title |
| | | Optima Chicago Center II 220 E. Illinois Street Chicago, IL | Caisson Plan |
| REVISIONS | | Project No. | Date |
| No. | Date: | Description: | |
| △ | | | 5140 |
| △ | | | 03.27.14 |
| △ | | | |
| | | Drawn By | Drawing No. |
| | | CSA | SSK-001 |
| | | Scale | |
| | | N.T.S. | |



City of Chicago



O2014-4841

Office of the City Clerk

Document Tracking Sheet

| | |
|---------------------------------|--|
| Meeting Date: | 5/28/2014 |
| Sponsor(s): | Reilly (42) |
| Type: | Ordinance |
| Title: | Grant(s) of privilege in public way for Northwestern University/Chicago Campus - sheetings |
| Committee(s) Assignment: | Committee on Transportation and Public Way |

ORDINANCE
NORTHWESTERN UNIVERSITY/CHICAGO CAMPUS
Acct. No. 69296 - 5
Permit No. 1112313

Be It Ordained by the City Council of the City of Chicago:

SECTION 1. Permission and authority are hereby given and granted to NORTHWESTERN UNIVERSITY/CHICAGO CAMPUS, upon the terms and subject to the conditions of this ordinance to maintain and use, as now constructed, four (4) areas Sheeting under the public right-of-way adjacent to its premises known as 321 E. Erie St..

Said Sheeting(s) at E. Erie measure(s):

Two (2) at one (1) foot in length, and eight (8) feet in width for a total of sixteen (16) square feet.

Said Sheeting(s) at E. Ontario measure(s):

Two (2) at one (1) foot in length, and eight (8) feet in width for a total of sixteen (16) square feet.

The location of said privilege shall be as shown on prints kept on file with the Department of Business Affairs and Consumer Protection and the Office of the City Clerk.

Said privilege shall be constructed in accordance with plans and specifications approved by the Department of Planning and Development and Department of Transportation (Office of Underground Coordination).

This grant of privilege in the public way shall be subject to the provisions of Section 10-28-015 and all other required provisions of the Municipal Code of Chicago.

The grantee shall pay to the City of Chicago as compensation for the privilege #1112313 herein granted the sum of eight hundred (\$800.00) per annum in advance.

A 25% penalty will be added for payments received after due date.

The permit holder agrees to hold the City of Chicago harmless for any damage, relocation or replacement costs associated with damage, relocation or removal of private property caused by the City performing work in the public way.

Authority herein given and granted for a period of five (5) years from and after 03/31/2014.

Alderman _____

Brendan Reilly 42nd Ward

Handwritten text, possibly a signature or name, located in the lower-left quadrant of the page. The text is faint and difficult to decipher, but appears to consist of several words or a short phrase.

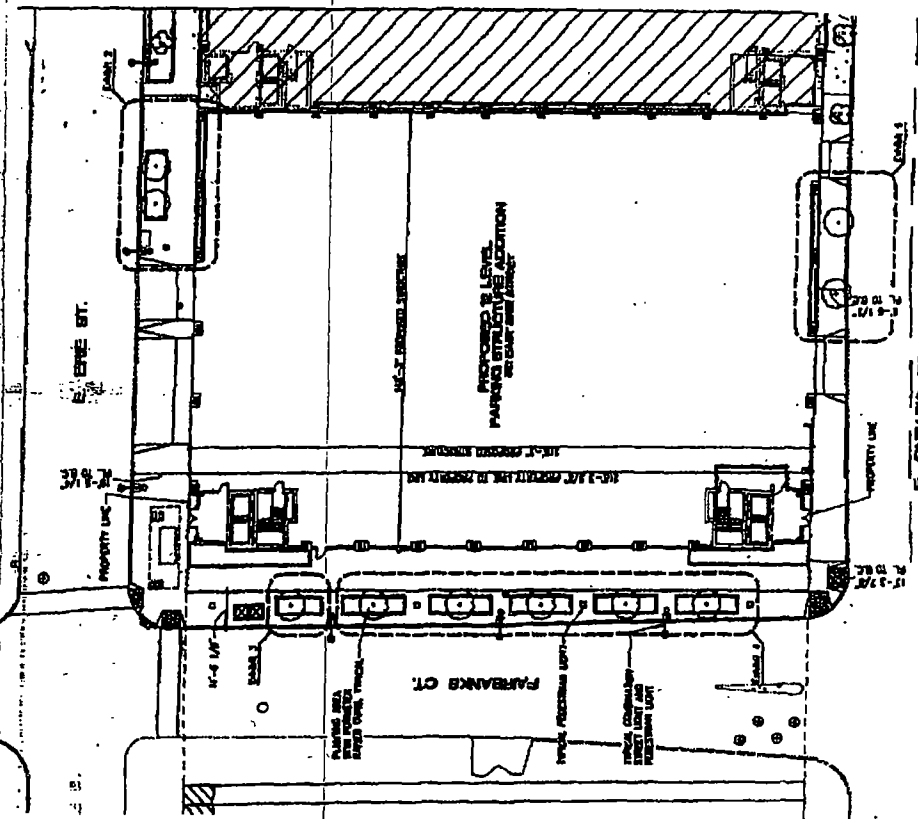

No. Exhibit - 1
 JAC. KORNBERG-BEL
 Job No. 314380-00
 Date 01/20/04

WALKER
 ARCHITECTS
 8702 Drake Road
 Dept. 11 601723
 Phone 847 267 2600

100 SOUTH PEARSONS COURT
 CHICAGO, ILLINOIS 60641
 TEL: 312 467 1100
 FAX: 312 467 1101

Curis 30750 1 Bel



City of Chicago



O2014-4844

Office of the City Clerk

Document Tracking Sheet

| | |
|---------------------------------|--|
| Meeting Date: | 5/28/2014 |
| Sponsor(s): | Reilly (42) |
| Type: | Ordinance |
| Title: | Grant(s) of privilege in public way for Northwestern University/Chicago Campus - tree grates |
| Committee(s) Assignment: | Committee on Transportation and Public Way |

ORDINANCE
NORTHWESTERN UNIVERSITY/CHICAGO CAMPUS
Acct. No. 69296 - 5
Permit No. 1112656

Be It Ordained by the City Council of the City of Chicago:

SECTION 1. Permission and authority are hereby given and granted to NORTHWESTERN UNIVERSITY/CHICAGO CAMPUS, upon the terms and subject to the conditions of this ordinance to maintain and use, as now constructed, two (2) Tree Grates(s) on the public right-of-way adjacent to its premises known as 321 E. Erie St..

Said Tree Grates(s) at E. Ontario measure(s):

Two (2) at six (6) feet in length, and six (6) feet in width for a total of seventy-two (72) square feet.

The location of said privilege shall be as shown on prints kept on file with the Department of Business Affairs and Consumer Protection and the Office of the City Clerk.

Said privilege shall be constructed in accordance with plans and specifications approved by the Department of Planning and Development and Department of Transportation (Division of Project Development).

This grant of privilege in the public way shall be subject to the provisions of Section 10-28-015 and all other required provisions of the Municipal Code of Chicago.

The grantee shall pay to the City of Chicago as compensation for the privilege #1112656 herein granted the sum of zero (\$0.00) per annum in advance.

A 25% penalty will be added for payments received after due date.

The permit holder agrees to hold the City of Chicago harmless for any damage, relocation or replacement costs associated with damage, relocation or removal of private property caused by the City performing work in the public way.

Authority herein given and granted for a period of five (5) years from and after 03/31/2014.

Alderman _____

Brendan Reilly 42nd Ward

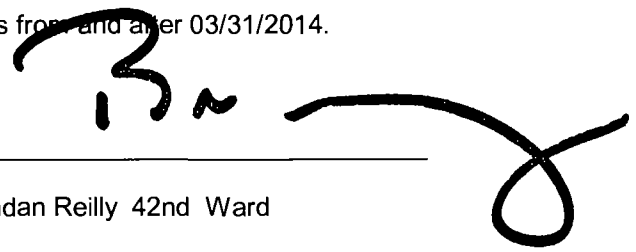

Handwritten scribbles and faint markings, possibly a signature or initials, located in the lower-left quadrant of the page.

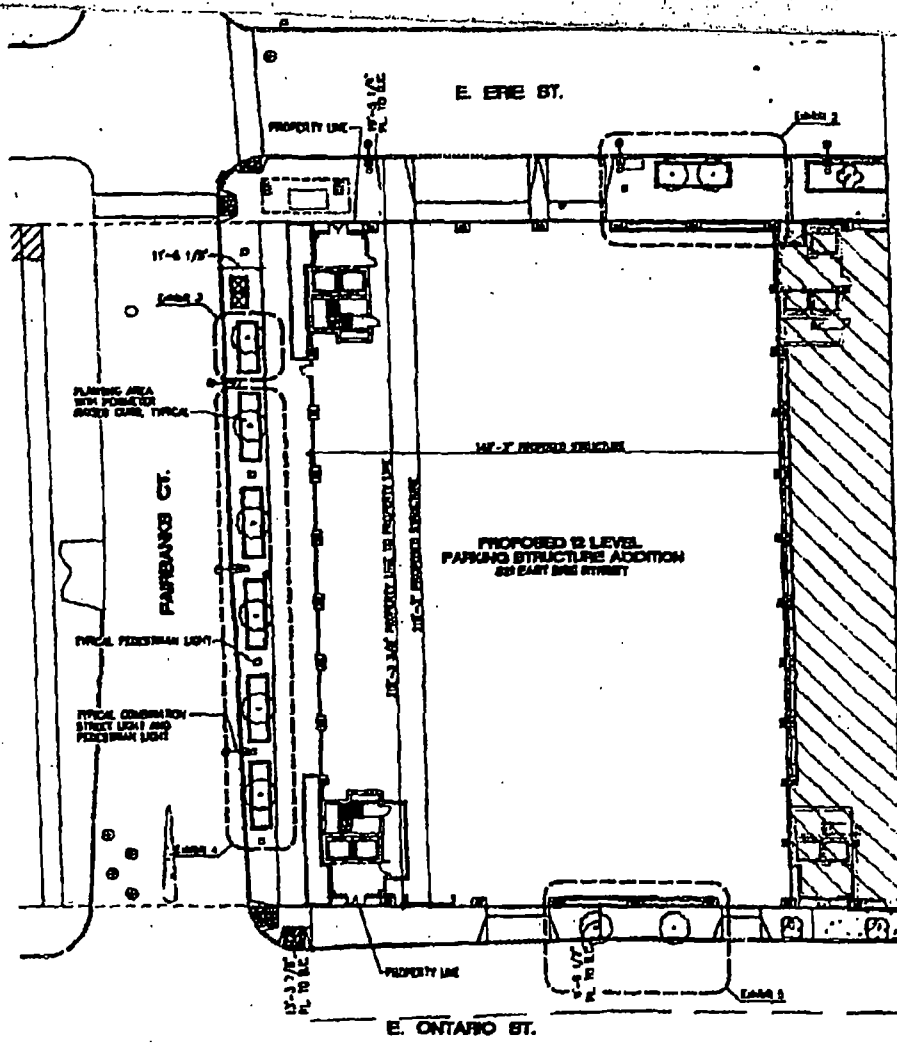

WALKER
ENGINEERING
503 Doss Road
Elyria, OH 44033
Phone: 447.667.2040

Job: NORTHWESTERN - BR 1

Job No: 316380.20

Date: 01/20/04

No.

Exhibit - 1



City of Chicago



O2014-4869

Office of the City Clerk

Document Tracking Sheet

| | |
|---------------------------------|--|
| Meeting Date: | 5/28/2014 |
| Sponsor(s): | Reilly (42) |
| Type: | Ordinance |
| Title: | Grant(s) of privilege in public way for Original Hair Designers, The |
| Committee(s) Assignment: | Committee on Transportation and Public Way |

ORDINANCE
THE ORIGINAL HAIR DESIGNERS
Acct. No. 27040 - 1
Permit No. 1112729

Be It Ordained by the City Council of the City of Chicago:

SECTION 1. Permission and authority are hereby given and granted to THE ORIGINAL HAIR DESIGNERS, upon the terms and subject to the conditions of this ordinance to maintain and use one (1) sign(s) projecting over the public right-of-way attached to its premises known as 134 N. Wells St..

Said sign structure(s) measures as follows; along N. Wells Street:
One (1) at one point eight three (1.83) feet in length, six point two five (6.25) feet in height and twelve (12) feet above grade level.

The location of said privilege shall be as shown on prints kept on file with the Department of Business Affairs and Consumer Protection and the Office of the City Clerk.

Said privilege shall be constructed in accordance with plans and specifications approved by the Department of Transportation (Division of Project Development) and Zoning Department - Signs.

This grant of privilege in the public way shall be subject to the provisions of Section 10-28-015 and all other required provisions of the Municipal Code of Chicago.

The grantee shall pay to the City of Chicago as compensation for the privilege #1112729 herein granted the sum of one hundred (\$100.00) per annum in advance.

A 25% penalty will be added for payments received after due date.

The permit holder agrees to hold the City of Chicago harmless for any damage, relocation or replacement costs associated with damage, relocation or removal of private property caused by the City performing work in the public way.

Authority herein given and granted for a period of five (5) years from and after 05/13/2014.

Alderman _____

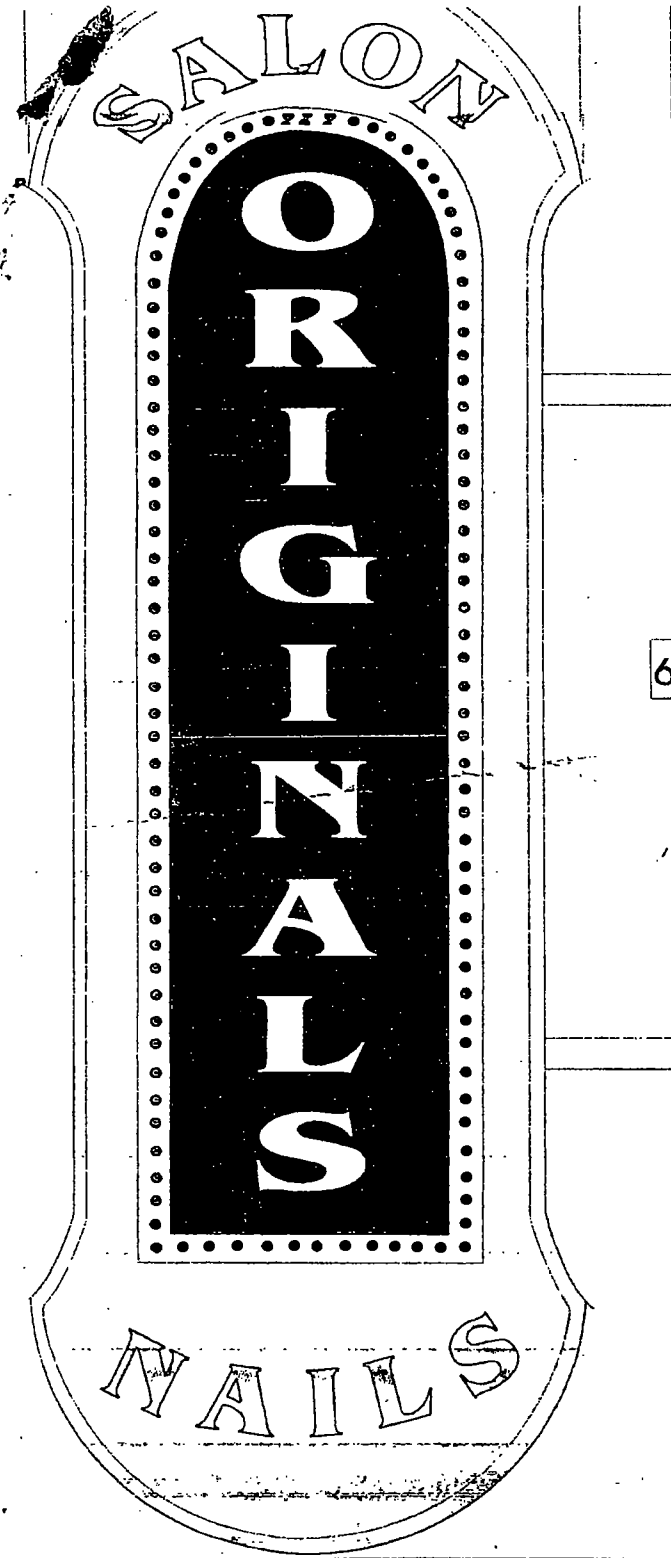

Brendan Reilly 42nd Ward

Handwritten scribbles and marks, possibly a signature or initials, located in the lower-left quadrant of the page.

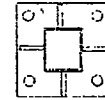

REQUIRED SIGN READER
 SALON-ORIGINALS-NAILS
 ACRYLIC FLAT LASER CUT-OUT
 LETTERS, MOUNTED ON LEXAN
 PANELS WITH VYNIL BACKGROUND.
 COLORS SHOWING ACCORDING TO
 CUSTOMERS ARTWORK AND IDEA.

MOUNTING PLATE
 6" X 6" X 3" X 3"



4

6'-3"

THE ORIGINALS Hair Designers
 205 W. RANDOLPH ST.
 CHICAGO, IL. 60606
 312.236-1139

CONTACT

| | | |
|------------------|-------------------------|------------------|
| DATE | 07-29-03 | DESIGNER CAESAR |
| SCALE | NONE | TYPE DOUBLE-FACE |
| FILE NAME | ORIGIN.EPS | |
| NOTES | ATTN? JOHN 312.236.3891 | |
| SIGN DESCRIPTION | | |



City of Chicago



O2014-4870

Office of the City Clerk

Document Tracking Sheet

Meeting Date: 5/28/2014

Sponsor(s): Reilly (42)

Type: Ordinance

Title: Grant(s) of privilege in public way for River Point LLC -
foundation support

Committee(s) Assignment: Committee on Transportation and Public Way

ORDINANCE
RIVER POINT LLC
Acct. No. 389719 - 1
Permit No. 1112532

Be It Ordained by the City Council of the City of Chicago:

SECTION 1. Permission and authority are hereby given and granted to RIVER POINT LLC, upon the terms and subject to the conditions of this ordinance to construct, install, maintain and use Foundation Support(s) (Footing) under the public right-of-way adjacent to its premises known as 444 W. Lake St. .

Said Foundation Support(s) (Footing) at N. Canal Street measure(s):

One (1) at eighty-four point seven five (84.75) feet in length, and eighteen point nine two (18.92) feet in width for a total of one thousand six hundred three point four seven (1603.47) square feet. Said foundation supports (footing/structural beams/walls) shall be used for driveway elevation to support parking garage.

The location of said privilege shall be as shown on prints kept on file with the Department of Business Affairs and Consumer Protection and the Office of the City Clerk.

Said privilege shall be constructed in accordance with plans and specifications approved by the Department of Planning and Development and Department of Transportation (Office of Underground Coordination).

This grant of privilege in the public way shall be subject to the provisions of Section 10-28-015 and all other required provisions of the Municipal Code of Chicago.

The grantee shall pay to the City of Chicago as compensation for the privilege #1112532 herein granted the sum of one thousand twenty-six (\$1,026.00) per annum in advance.

A 25% penalty will be added for payments received after due date.

The permit holder agrees to hold the City of Chicago harmless for any damage, relocation or replacement costs associated with damage, relocation or removal of private property caused by the City performing work in the public way.

Authority herein given and granted for a period of five (5) years from and after Date of Passage.

Alderman _____

Brendan Reilly 42nd Ward

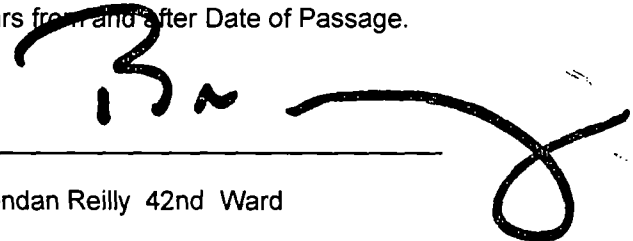
A large, stylized handwritten signature in black ink, appearing to read 'B. Reilly', is written over the signature line and extends to the right.

RIVERPOINT LLC
ONE SOUTH DEARBORN
SUITE 2000
CHICAGO, IL 60603

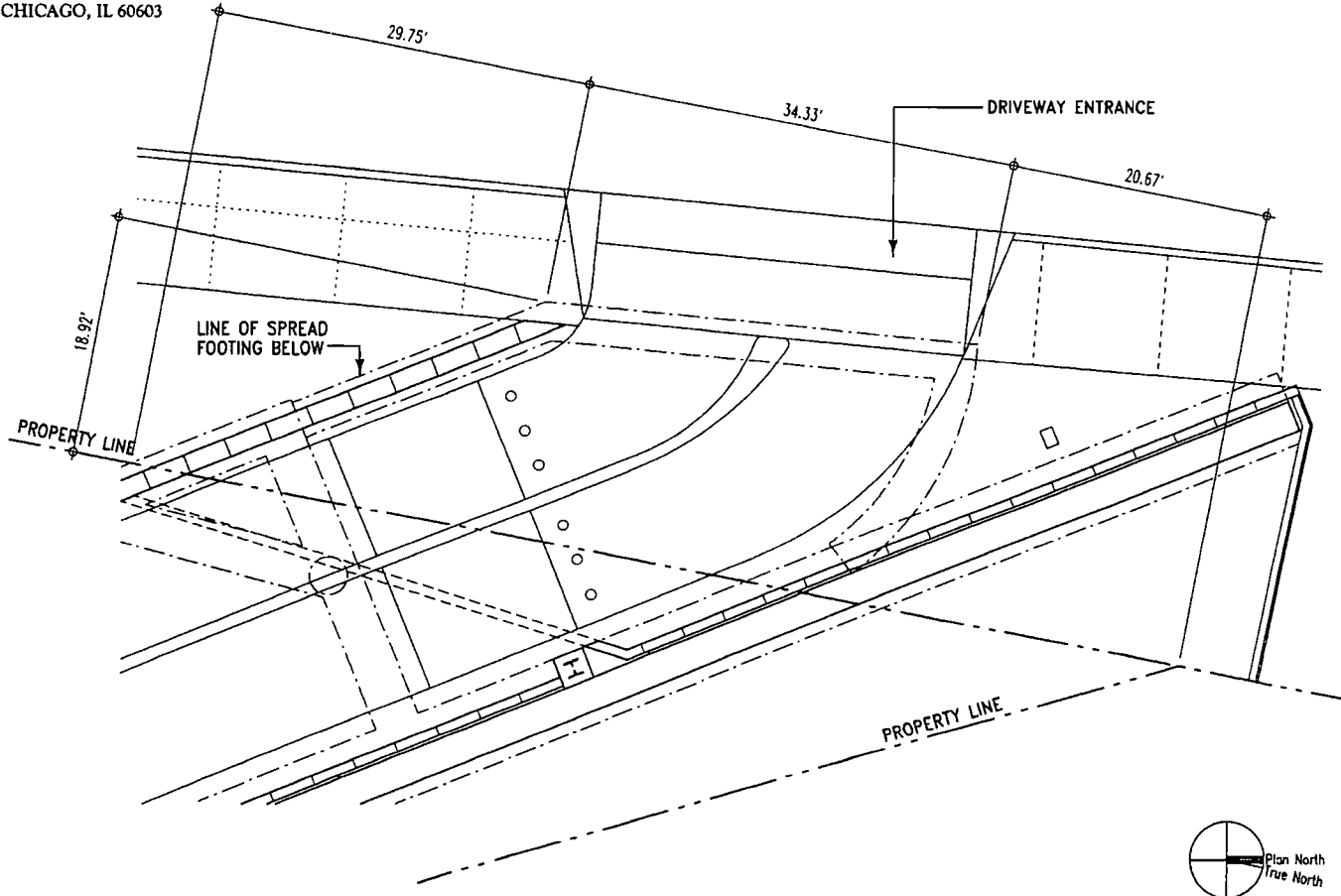

RIVER POINT TOWER - ENLARGED PLAN AT RAMP ENTRANCE

SCALE: 3/32"=1'-0"

KENDALL/HEATON ASSOCIATES INC. 3050 POST OAK BLVD SUITE 1000 HOUSTON TEXAS 77056

Job No. 06008

Date: 14 MAR 14

FIGURE 3



City of Chicago



O2014-4871

Office of the City Clerk

Document Tracking Sheet

| | |
|---------------------------------|--|
| Meeting Date: | 5/28/2014 |
| Sponsor(s): | Reilly (42) |
| Type: | Ordinance |
| Title: | Grant(s) of privilege in public way for River Point LLC - irrigation system |
| Committee(s) Assignment: | Committee on Transportation and Public Way |

ORDINANCE
RIVER POINT LLC
Acct. No. 389719 - 1
Permit No. 1112534

Be It Ordained by the City Council of the City of Chicago:

SECTION 1. Permission and authority are hereby given and granted to RIVER POINT LLC, upon the terms and subject to the conditions of this ordinance to construct, install, maintain and use eight (8) Irrigation System(s) under the public right-of-way adjacent to its premises known as 444 W. Lake St..

Said Irrigation System(s) at N. Canal Street measure(s):

- One (1) at fifty-one (51) feet in length, and six (6) feet in width for a total of three hundred six (306) square feet.
- One (1) at thirty-one (31) feet in length, and six (6) feet in width for a total of one hundred eighty-six (186) square feet.
- One (1) at thirty-one (31) feet in length, and six (6) feet in width for a total of one hundred eighty-six (186) square feet.
- One (1) at thirty-one (31) feet in length, and six (6) feet in width for a total of one hundred eighty-six (186) square feet.
- One (1) at forty-six point five three (46.53) feet in length, and six (6) feet in width for a total of two hundred seventy-nine point one eight (279.18) square feet.
- One (1) at eighty-two point five nine (82.59) feet in length, and six (6) feet in width for a total of four hundred ninety-five point five four (495.54) square feet.
- One (1) at forty-two point four (42.4) feet in length, and six (6) feet in width for a total of two hundred fifty-four point four (254.4) square feet.
- One (1) at thirty-eight point eight seven (38.87) feet in length, and six (6) feet in width for a total of two hundred thirty-three point two two (233.22) square feet.

The location of said privilege shall be as shown on prints kept on file with the Department of Business Affairs and Consumer Protection and the Office of the City Clerk.

Said privilege shall be constructed in accordance with plans and specifications approved by the Department of Transportation (Office of Underground Coordination) and Department of Water Management.

This grant of privilege in the public way shall be subject to the provisions of Section 10-28-015 and all other required provisions of the Municipal Code of Chicago.

The grantee shall pay to the City of Chicago as compensation for the privilege #1112534 herein granted the sum of one thousand three hundred sixty-one (\$1,361.00) per annum in advance.

A 25% penalty will be added for payments received after due date.

The permit holder agrees to hold the City of Chicago harmless for any damage, relocation or replacement costs associated with damage, relocation or removal of private property caused by the City performing work in the public way.

Authority herein given and granted for a period of five (5) years from and after Date of Passage.

Alderman _____

Brendan Reilly 42nd Ward



RIVERPOINT LLC
ONE SOUTH DEARBORN /
SUITE 2000
CHICAGO, IL 60603

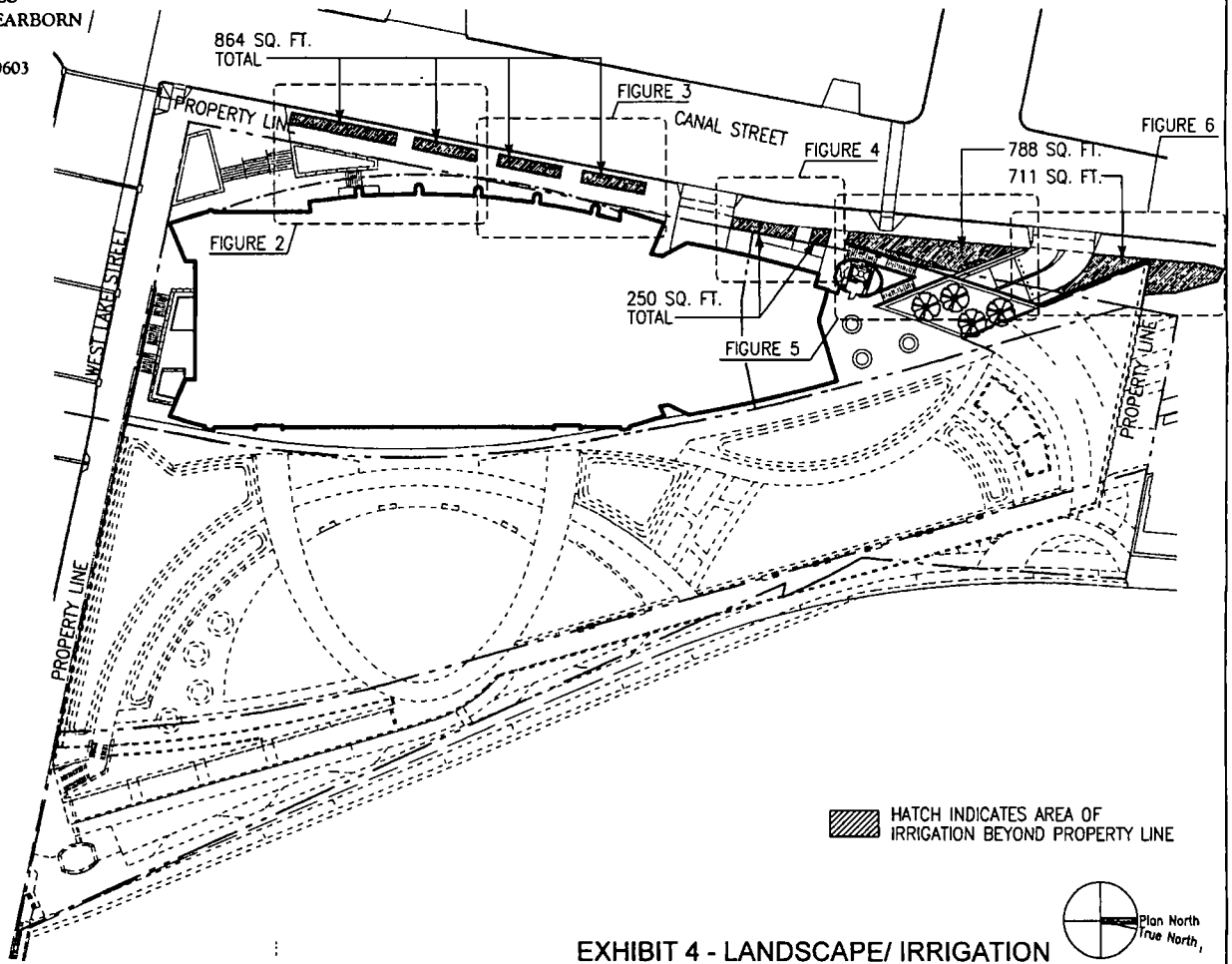

EXHIBIT 4 - LANDSCAPE/ IRRIGATION

RIVER POINT TOWER - OVERALL IRRIGATION PLAN

N.T.S.

KENDALL/HEATON ASSOCIATES INC. 3050 POST OAK BLVD SUITE 1000 HOUSTON TEXAS 77056

Job No. 06008

Date: 18 MAR 14

FIGURE 1



City of Chicago



O2014-4872

Office of the City Clerk

Document Tracking Sheet

| | |
|---------------------------------|---|
| Meeting Date: | 5/28/2014 |
| Sponsor(s): | Reilly (42) |
| Type: | Ordinance |
| Title: | Grant(s) of privilege in public way for River Point LLC - staircase |
| Committee(s) Assignment: | Committee on Transportation and Public Way |

ORDINANCE
RIVER POINT LLC
Acct. No. 389719 - 1
Permit No. 1112529

Be It Ordained by the City Council of the City of Chicago:

SECTION 1. Permission and authority are hereby given and granted to RIVER POINT LLC, upon the terms and subject to the conditions of this ordinance to construct, install, maintain and use a Stair Case on the public right-of-way adjacent to its premises known as 444 W. Lake St..

Said Stair Case at N. Canal Street measure(s):

One (1) at forty-two (42) feet in length, and four point seven eight (4.78) feet in width for a total of two hundred point seven six (200.76) square feet.

The location of said privilege shall be as shown on prints kept on file with the Department of Business Affairs and Consumer Protection and the Office of the City Clerk.

Said privilege shall be constructed in accordance with plans and specifications approved by the Department of Transportation (Division of Project Development).

This grant of privilege in the public way shall be subject to the provisions of Section 10-28-015 and all other required provisions of the Municipal Code of Chicago.

The grantee shall pay to the City of Chicago as compensation for the privilege #1112529 herein granted the sum of four thousand three hundred sixty-eight (\$4,368.00) per annum in advance.

A 25% penalty will be added for payments received after due date.

The permit holder agrees to hold the City of Chicago harmless for any damage, relocation or replacement costs associated with damage, relocation or removal of private property caused by the City performing work in the public way.

Authority herein given and granted for a period of five (5) years from and after Date of Passage.

Alderman _____

Brendan Reilly 42nd Ward

Handwritten scribbles and marks, possibly including a signature or initials.

RIVERPOINT LLC
ONE SOUTH DEARBORN
SUITE 2000
CHICAGO, IL 60603

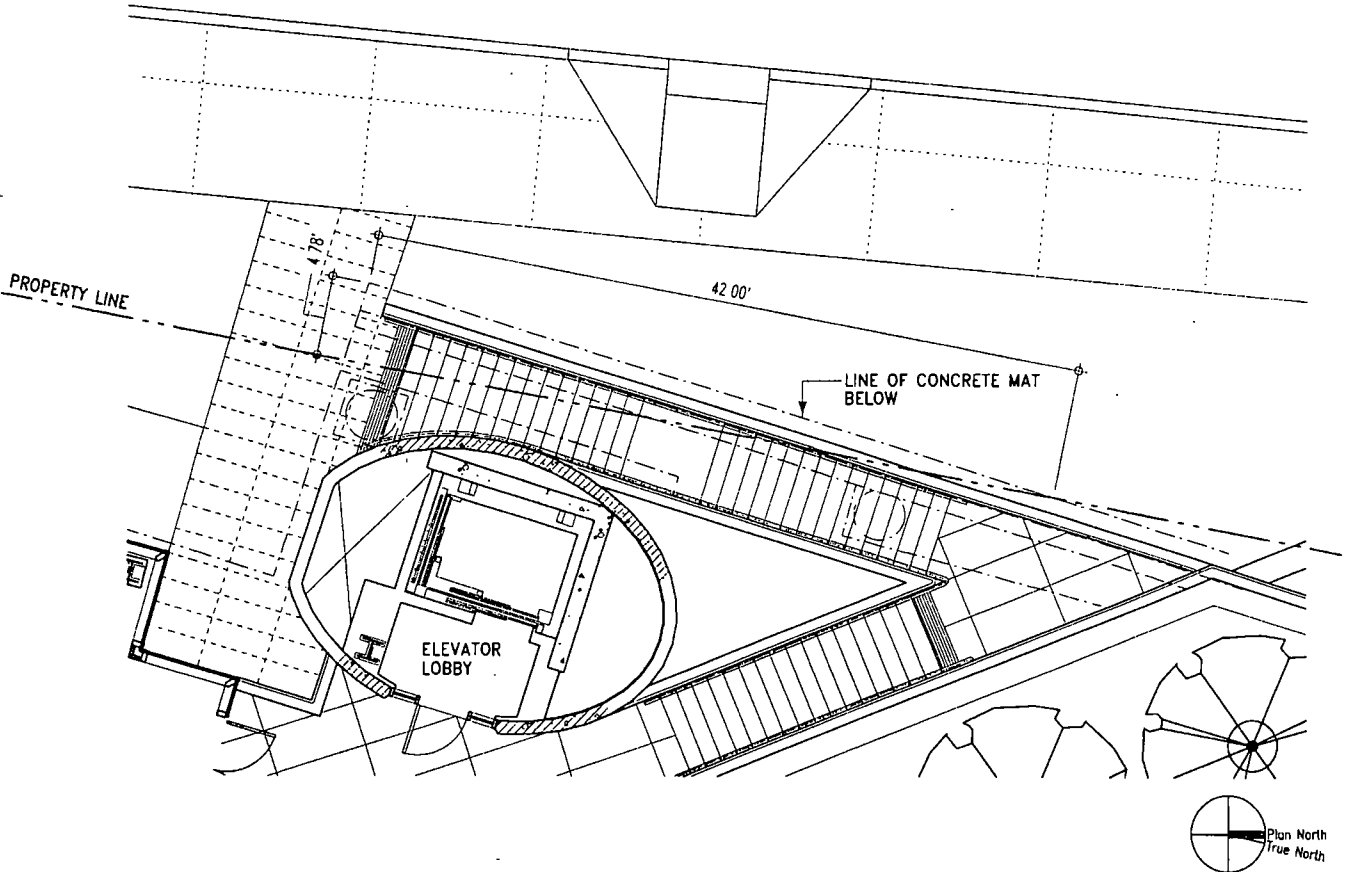

RIVER POINT TOWER - ENLARGED PLAN AT PE23

SCALE: 1/8"=1'-0"

KENDALL/HEATON ASSOCIATES INC. 3050 POST OAK BLVD SUITE 1000 HOUSTON TEXAS 77056

Job No. 06008

Date: 14 MAR 14

FIGURE 2



City of Chicago



O2014-4873

Office of the City Clerk

Document Tracking Sheet

| | |
|---------------------------------|---|
| Meeting Date: | 5/28/2014 |
| Sponsor(s): | Reilly (42) |
| Type: | Ordinance |
| Title: | Grant(s) of privilege in public way for Saks Fifth Avenue |
| Committee(s) Assignment: | Committee on Transportation and Public Way |

ORDINANCE
SAKS FIFTH AVE
Acct. No. 350794 - 1
Permit No. 1112926

Be It Ordained by the City Council of the City of Chicago:

SECTION 1. Permission and authority are hereby given and granted to SAKS FIFTH AVE, upon the terms and subject to the conditions of this ordinance to maintain and use, as now constructed, four (4) Planter Curb(s) on the public right-of-way for beautification purposes adjacent to its premises known as 700 N. Michigan Ave..

Said Planter Curb(s) at E Superior St measure(s):

Four (4) at forty (40) feet in length, and ten (10) feet in width for a total of one thousand six hundred (1600) square feet.

Grantee must allow the required clear and unobstructed space for pedestrian passage at all times per rules and regulations approved by the Department of Transportation.

The location of said privilege shall be as shown on prints kept on file with the Department of Business Affairs and Consumer Protection and the Office of the City Clerk.

Said privilege shall be constructed in accordance with plans and specifications approved by the Department of Planning and Development and Department of Transportation (Division of Project Development).

This grant of privilege in the public way shall be subject to the provisions of Section 10-28-015 and all other required provisions of the Municipal Code of Chicago.

The grantee shall pay to the City of Chicago as compensation for the privilege #1112926 herein granted the sum of zero (\$0.00) per annum in advance.

A 25% penalty will be added for payments received after due date.

The permit holder agrees to hold the City of Chicago harmless for any damage, relocation or replacement costs associated with damage, relocation or removal of private property caused by the City performing work in the public way.

Authority herein given and granted for a period of five (5) years from and after Date of Passage.

Alderman _____

Brendan Reilly 42nd Ward

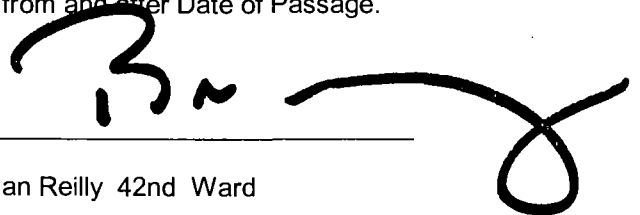
A large, stylized handwritten signature in black ink, appearing to read 'B. Reilly', is written over the signature line and extends to the right.

Handwritten scribbles or marks, possibly a signature or initials, located in the lower-left quadrant of the page.

E. SUPERIOR STREET

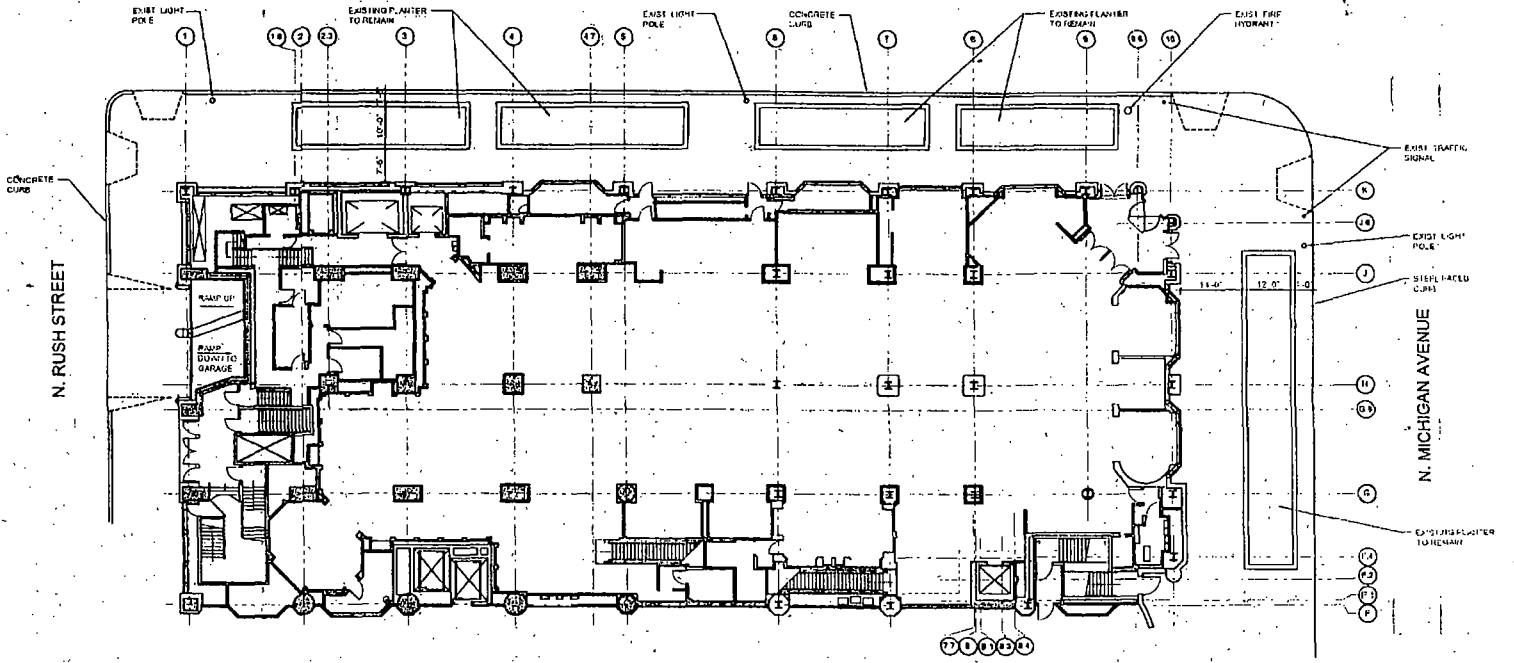

SAKS FIFTH AVENUE
700 N. MICHIGAN
CHICAGO, IL 60611
SCALE: 1/32" = 1'-0"





City of Chicago



O2014-4874

Office of the City Clerk

Document Tracking Sheet

| | |
|---------------------------------|--|
| Meeting Date: | 5/28/2014 |
| Sponsor(s): | Reilly (42) |
| Type: | Ordinance |
| Title: | Grant(s) of privilege in public way for Standard Parking |
| Committee(s) Assignment: | Committee on Transportation and Public Way |

ORDINANCE
STANDARD PARKING
Acct. No. 63160 - 252
Permit No. 1112956

Be It Ordained by the City Council of the City of Chicago:

SECTION 1. Permission and authority are hereby given and granted to STANDARD PARKING, upon the terms and subject to the conditions of this ordinance to maintain and use one (1) sign(s) projecting over the public right-of-way attached to its premises known as 400 E. South Water St..

Said sign structure(s) measures as follows; along E. South Water:

One (1) at six (6) feet in length, eight (8) feet in height and eighteen (18) feet above grade level.

The location of said privilege shall be as shown on prints kept on file with the Department of Business Affairs and Consumer Protection and the Office of the City Clerk.

Said privilege shall be constructed in accordance with plans and specifications approved by the Department of Transportation (Division of Project Development) and Zoning Department - Signs.

This grant of privilege in the public way shall be subject to the provisions of Section 10-28-015 and all other required provisions of the Municipal Code of Chicago.

The grantee shall pay to the City of Chicago as compensation for the privilege #1112956 herein granted the sum of three hundred (\$300.00) per annum in advance.

A 25% penalty will be added for payments received after due date.

The permit holder agrees to hold the City of Chicago harmless for any damage, relocation or replacement costs associated with damage, relocation or removal of private property caused by the City performing work in the public way.

Authority herein given and granted for a period of five (5) years from and after 05/13/2014.

Alderman _____

Brendan Reilly 42nd Ward

Handwritten scribbles or marks, possibly initials or a signature, located in the lower-left quadrant of the page.

4/11/2014

SP Plus Mail - Fwd:

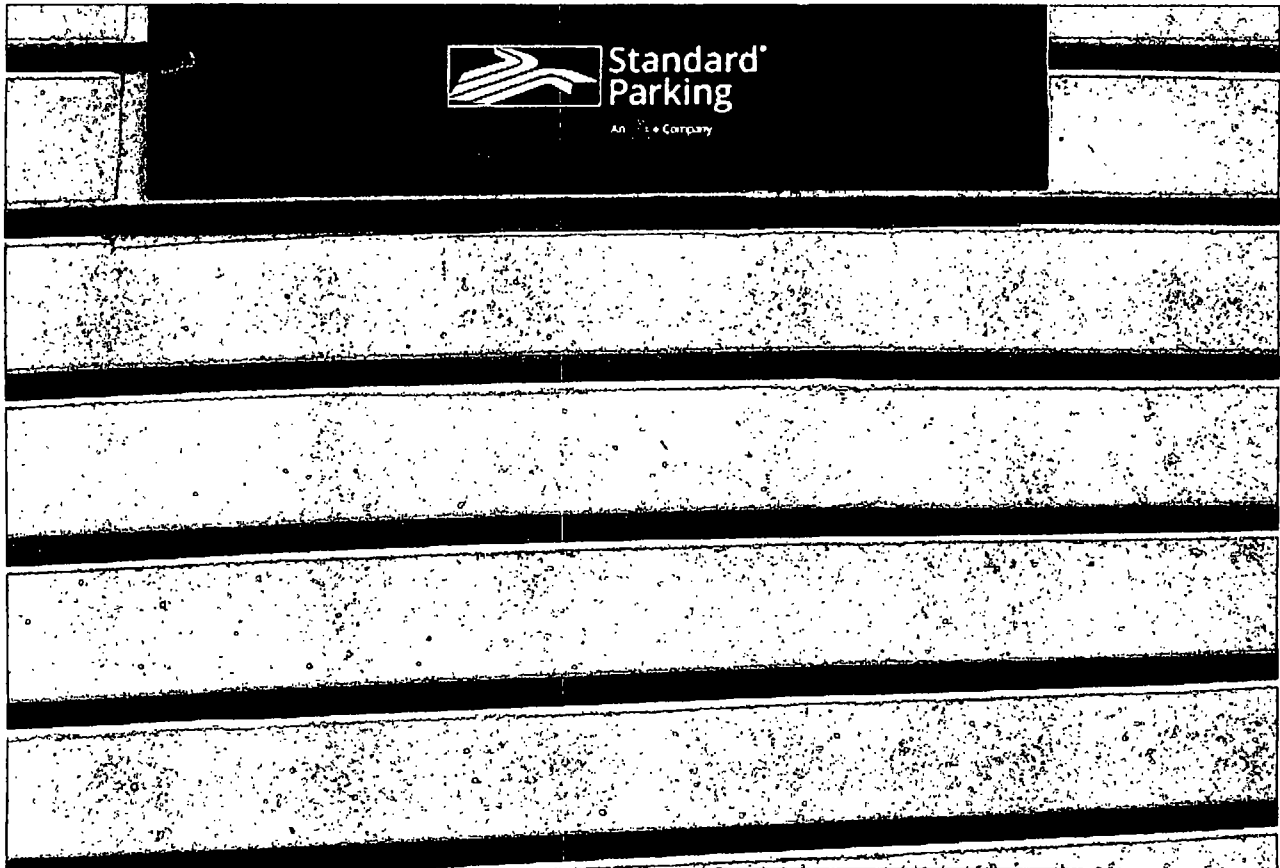



City of Chicago



O2014-4875

Office of the City Clerk

Document Tracking Sheet

| | |
|---------------------------------|--|
| Meeting Date: | 5/28/2014 |
| Sponsor(s): | Reilly (42) |
| Type: | Ordinance |
| Title: | Grant(s) of privilege in public way for Thor Palmer House Hotel & Shops LLC |
| Committee(s) Assignment: | Committee on Transportation and Public Way |

ORDINANCE
THOR PALMER HOUSE HOTEL & SHOPS, LLC
Acct. No. 309174 - 1
Permit No. 1109474

Be It Ordained by the City Council of the City of Chicago:

SECTION 1. Permission and authority are hereby given and granted to THOR PALMER HOUSE HOTEL & SHOPS, LLC, upon the terms and subject to the conditions of this ordinance to maintain and use, as now constructed, twenty-one (21) Facade(s) projecting over the public right-of-way adjacent to its premises known as 17 E. Monroe St..

Existing storefront facades over storefronts along South State Street measures as follows

Ten (10) at two point seven five (2.75) feet in length, and two point five (2.5) feet in width for a total of sixty-eight point seven five (68.75) square feet.

Nine (9) at one hundred fifty-three point four two (153.42) feet in length, and point zero eight (.08) feet in width for a total of one hundred ten point four six (110.46) square feet.

One (1) at forty point three three (40.33) feet in length, and point zero eight (.08) feet in width for a total of three point two three (3.23) square feet.

One (1) at two hundred fourteen (214) feet in length, and point zero eight (.08) feet in width for a total of seventeen point one two (17.12) square feet.

The location of said privilege shall be as shown on prints kept on file with the Department of Business Affairs and Consumer Protection and the Office of the City Clerk.

Said privilege shall be constructed in accordance with plans and specifications approved by the Department of Planning and Development and Department of Transportation (Division of Project Development).

This grant of privilege in the public way shall be subject to the provisions of Section 10-28-015 and all other required provisions of the Municipal Code of Chicago.

The grantee shall pay to the City of Chicago as compensation for the privilege #1109474 herein granted the sum of four thousand two hundred sixty-nine (\$4,269.00) per annum in advance.

A 25% penalty will be added for payments received after due date.

The permit holder agrees to hold the City of Chicago harmless for any damage, relocation or replacement costs associated with damage, relocation or removal of private property caused by the City performing work in the public way.

Authority herein given and granted for a period of five (5) years from and after 09/10/2013.

Alderman _____

Brendan Reilly 42nd Ward

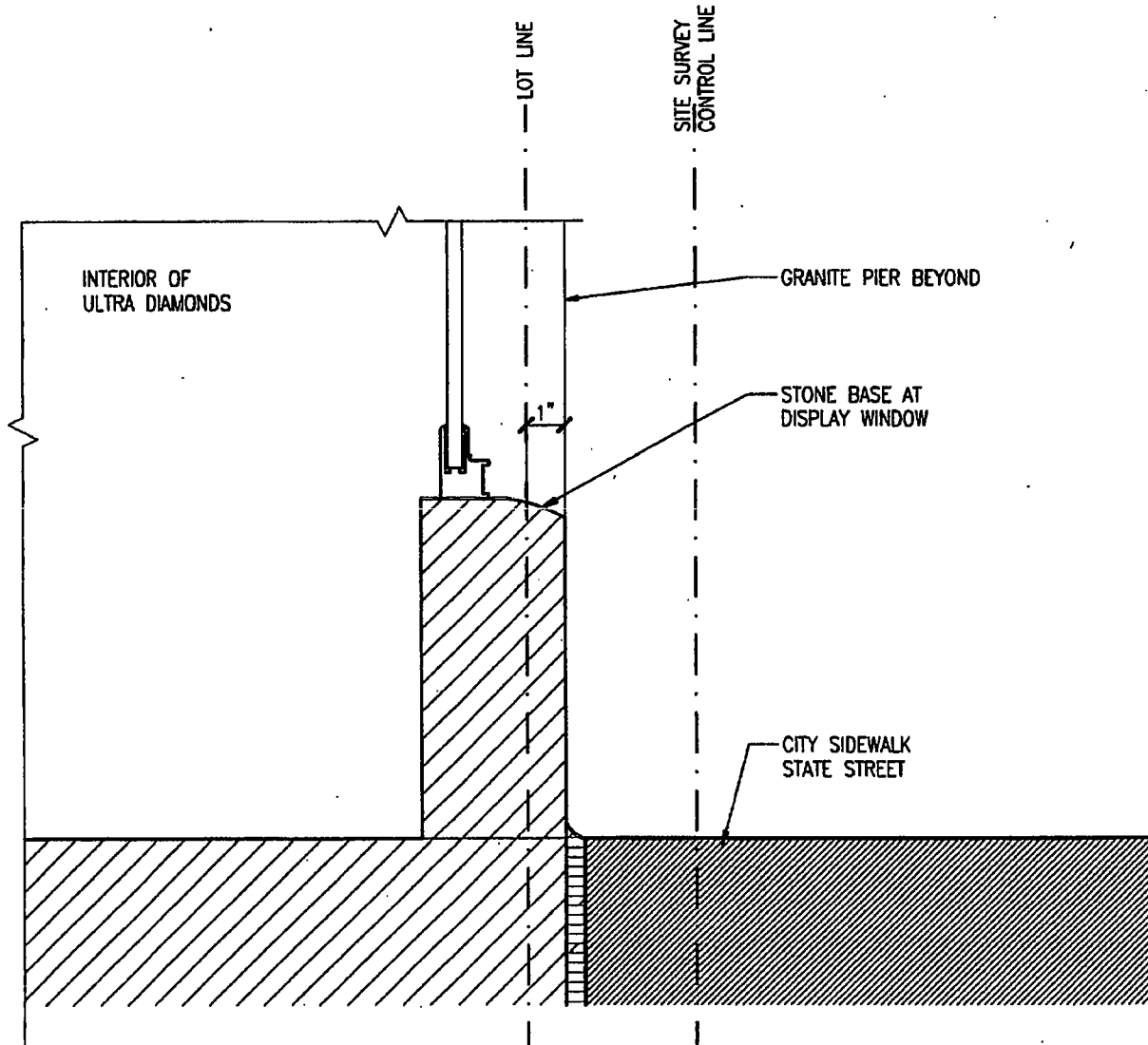

1 **EXISTING STORE-FRONT PROFILE**
SCALE: 3/4"=1'-0"

**LANDMARKED ULTRA DIAMONDS STOREFRONT-
FORMERLY PEACOCKS JEWELERS**

Loebl Schlossman & Hackl
Architecture • Planning • Interiors

233 North Michigan Avenue
Suite 3000
Chicago, Illinois 60601
312.565.1800 Telephone
312.565.5912 Facsimile
www.loebh.com

Copyright © 2006 Loebl Schlossman & Hackl Inc.

Palmer House
Restoration and Development

17 EAST MONROE STREET, CHICAGO, ILLINOIS 60603

Date: 11/05/07
Sheet Rvsd: NA
Scale: AS NOTED
Drawn By: ASWG
Project No.: 30501.20

Sheet No.: **ASK-342a**

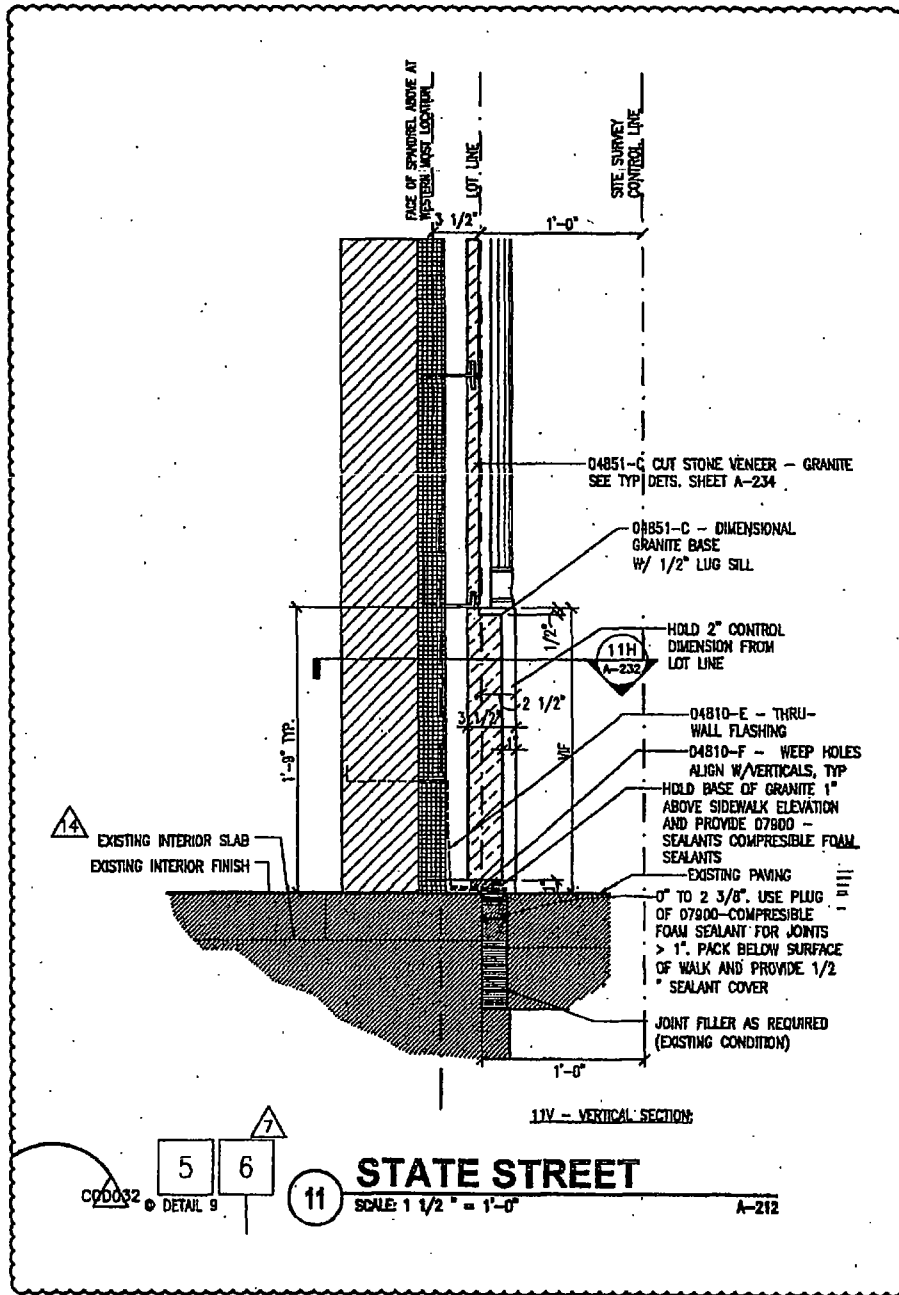

14

EXISTING INTERIOR SLAB
EXISTING INTERIOR FINISH

04851-C CUT STONE VENEER - GRANITE
SEE TYP DETS. SHEET A-234

04851-C - DIMENSIONAL
GRANITE BASE
W/ 1/2" LUG SILL

11H
A-232
HOLD 2" CONTROL
DIMENSION FROM
LOT LINE

04810-E - THRU-
WALL FLASHING

04810-F - WEEP HOLES
ALIGN W/ VERTICALS, TYP

HOLD BASE OF GRANITE 1"
ABOVE SIDEWALK ELEVATION
AND PROVIDE 07800 -
SEALANTS COMPRESSIBLE FOAM
SEALANTS

EXISTING PAVING

0" TO 2 3/8". USE PLUG
OF 07900-COMPRESSIBLE
FOAM SEALANT FOR JOINTS
> 1". PACK BELOW SURFACE
OF WALK AND PROVIDE 1/2"
SEALANT COVER

JOINT FILLER AS REQUIRED
(EXISTING CONDITION)

11V - VERTICAL SECTION

5 6 7
CDD032 DETAIL 9 11

STATE STREET

SCALE: 1/2" = 1'-0"

A-212

REVISIONS ISSUED BY CDD-032

Date: 01.25.07
Sheet: 032-232
Scale: R.I.S.
Drawn By: BSA
Project No: 00501.29
Sheet No: **ASK-341**

**Palmer House
Restoration and Development**

17 EAST MONROE STREET, CHICAGO, ILLINOIS 60603



Loeb Schlossman & Hackl
Architecture • Planning • Interiors

100 North Michigan Avenue
Chicago, Illinois 60611
312.527.2122
www.loebhackl.com

Copyright © 2007 Loeb Schlossman & Hackl Inc.



City of Chicago



O2014-4876

Office of the City Clerk

Document Tracking Sheet

| | |
|---------------------------------|---|
| Meeting Date: | 5/28/2014 |
| Sponsor(s): | Reilly (42) |
| Type: | Ordinance |
| Title: | Grant(s) of privilege in public way for Tower 10 Glades LLC |
| Committee(s) Assignment: | Committee on Transportation and Public Way |

ORDINANCE
TOWER 10 GLADES LLC
Acct. No. 381437 - 1
Permit No. 1112593

Be It Ordained by the City Council of the City of Chicago:

SECTION 1. Permission and authority are hereby given and granted to TOWER 10 GLADES LLC, upon the terms and subject to the conditions of this ordinance to construct, install, maintain and use one (1) Ice Melt System/Snow Melt System embedded in concrete under the public right-of-way adjacent to its premises known as 845 N. State St..

Said Ice Melt System/Snow Melt System at N. State Street measure(s):
One (1) at one hundred thirteen point five eight (113.58) feet in length, and six point nine two (6.92) feet in width for a total of seven hundred eighty-five point nine seven (785.97) square feet.

The location of said privilege shall be as shown on prints kept on file with the Department of Business Affairs and Consumer Protection and the Office of the City Clerk.

Said privilege shall be constructed in accordance with plans and specifications approved by the Department of Planning and Development and Department of Transportation (Office of Underground Coordination).

This grant of privilege in the public way shall be subject to the provisions of Section 10-28-015 and all other required provisions of the Municipal Code of Chicago.

The grantee shall pay to the City of Chicago as compensation for the privilege #1112593 herein granted the sum of one thousand five hundred nine (\$1,509.00) per annum in advance.

A 25% penalty will be added for payments received after due date.

The permit holder agrees to hold the City of Chicago harmless for any damage, relocation or replacement costs associated with damage, relocation or removal of private property caused by the City performing work in the public way.

Authority herein given and granted for a period of five (5) years from and after Date of Passage.

Alderman _____

Brendan Reilly 42nd Ward

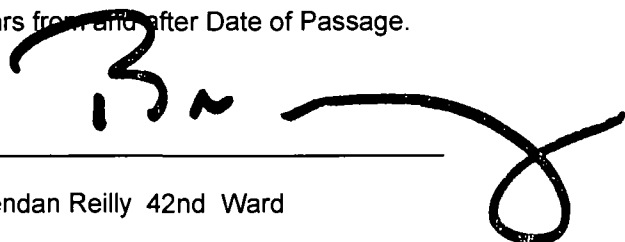
A handwritten signature in black ink, appearing to read 'Brendan Reilly', is written over a horizontal line. The signature is stylized and extends to the right of the line.

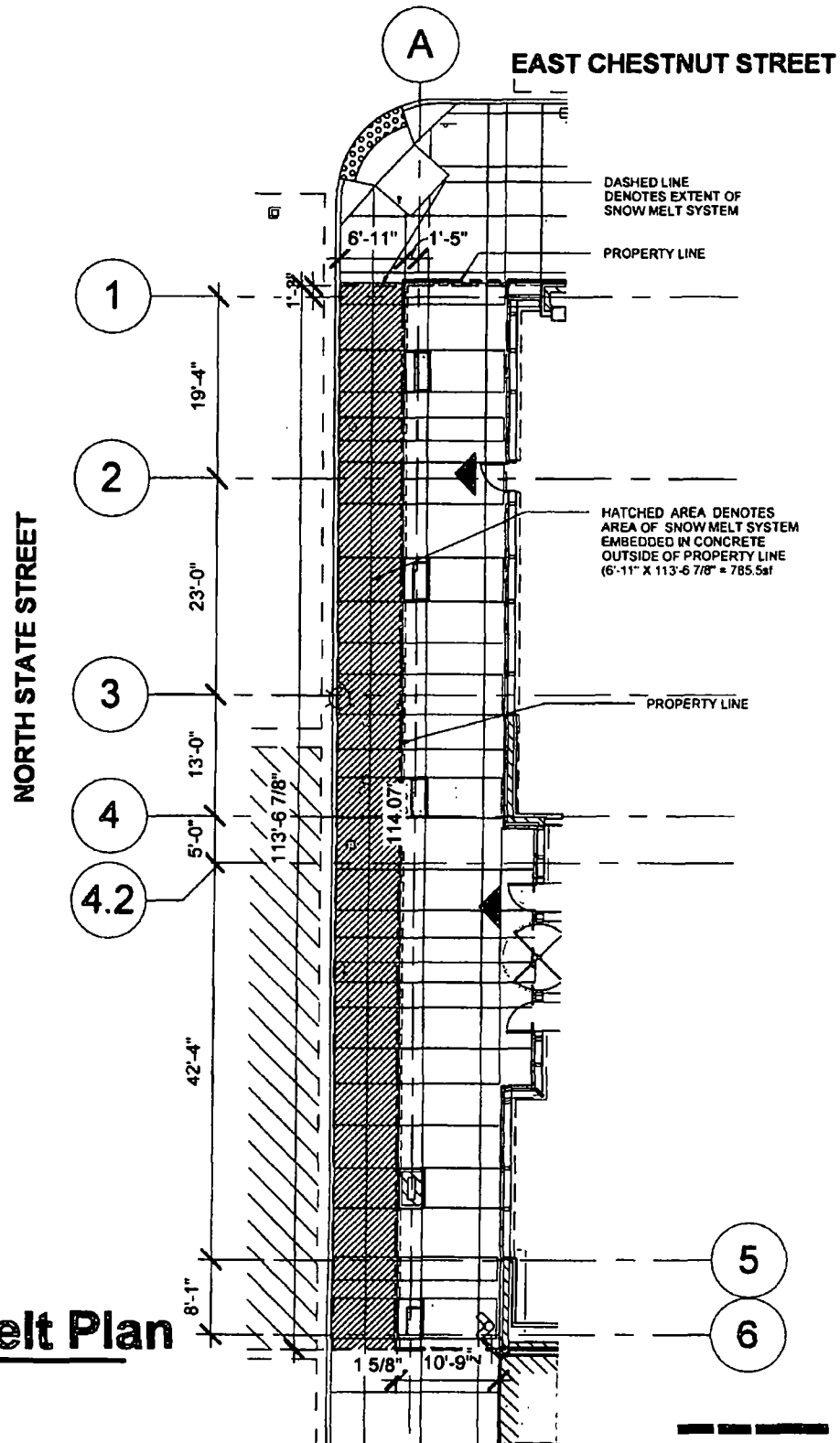

1 Snow Melt Plan
 SCALE: 1/16" = 1'-0"



PROJECT NAME: 845 N. State Street, Chicago, IL DATE: 02.20.2014

PROJECT NO: 2011008 DTL/SHT. REF.: A1.01 REV.:

© 2012 SCB DRAWING TITLE: Snow Melt Right-of-way Exhibit SHEET 1 of 1

Architecture Planning Interior Design 625 N Michigan Ave. Chicago, IL 60611 T 312 896 1100 F 312.896.1200



City of Chicago



O2014-4877

Office of the City Clerk Document Tracking Sheet

| | |
|---------------------------------|---|
| Meeting Date: | 5/28/2014 |
| Sponsor(s): | Reilly (42) |
| Type: | Ordinance |
| Title: | Grant(s) of privilege in public way for Tumi Stores, Inc. |
| Committee(s) Assignment: | Committee on Transportation and Public Way |

ORDINANCE
TUMI STORES INC
Acct. No. 324789 - 3
Permit No. 1111694

Be It Ordained by the City Council of the City of Chicago:

SECTION 1. Permission and authority are hereby given and granted to TUMI STORES INC, upon the terms and subject to the conditions of this ordinance to maintain and use one (1) sign(s) projecting over the public right-of-way attached to its premises known as 645 N. Michigan Ave..

Said sign structure(s) measures as follows; along N. Michigan Avenue:
One (1) at six point five eight (6.58) feet in length, one point seven five (1.75) feet in height and fourteen (14) feet above grade level.

The location of said privilege shall be as shown on prints kept on file with the Department of Business Affairs and Consumer Protection and the Office of the City Clerk.

Said privilege shall be constructed in accordance with plans and specifications approved by the Department of Transportation (Division of Project Development) and Zoning Department - Signs.

This grant of privilege in the public way shall be subject to the provisions of Section 10-28-015 and all other required provisions of the Municipal Code of Chicago.

The grantee shall pay to the City of Chicago as compensation for the privilege #1111694 herein granted the sum of one hundred (\$100.00) per annum in advance.

A 25% penalty will be added for payments received after due date.

The permit holder agrees to hold the City of Chicago harmless for any damage, relocation or replacement costs associated with damage, relocation or removal of private property caused by the City performing work in the public way.

Authority herein given and granted for a period of five (5) years from and after Date of Passage.

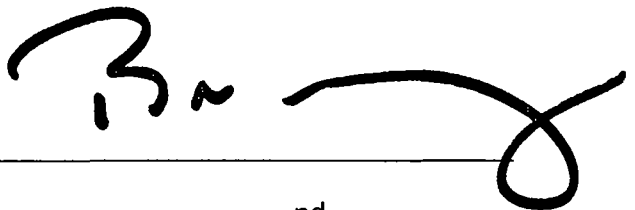
Alderman 
Brendan Reilly 42nd Ward

Handwritten scribbles and marks at the bottom of the page, possibly representing a signature or initials.

INTERIOR VESTIBULE ELEVATION
SCALE: 1/4" = 1'-0"

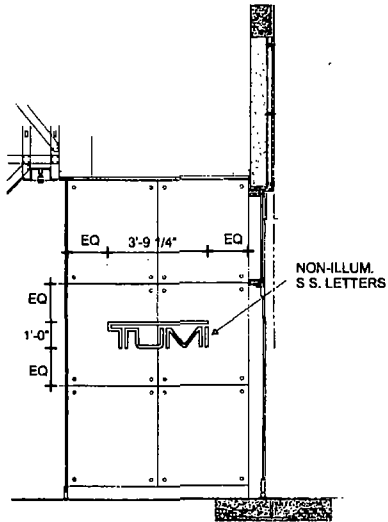

STORE FRONT EXTERIOR ELEVATION
SCALE: 1/4" = 1'-0"

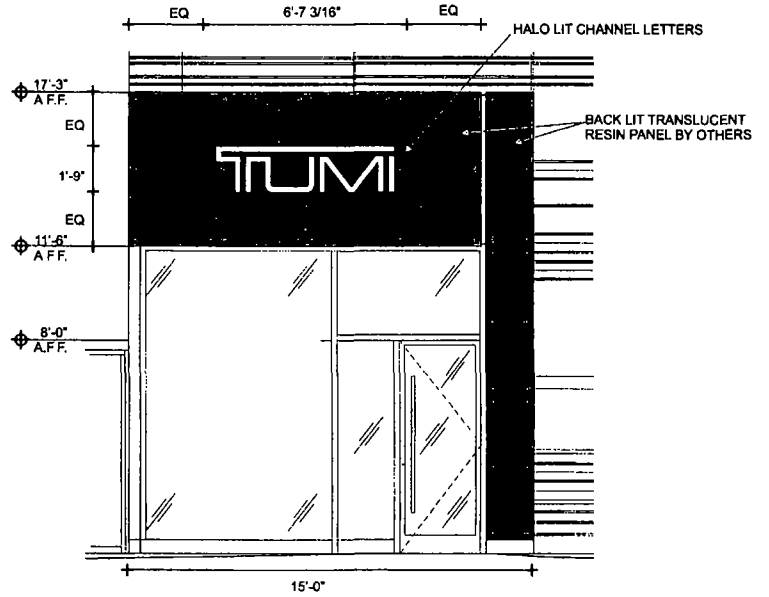

R2-UPDATE ELEVATIONS
R1-R1-CHANGE ENTRY LTRS TO HALO REDUCE SIZE
R1-ADD S.S. LTRS

**TRIANGLE
SIGN & SERVICE**

CLIENT & LOCATION



645 N MICHIGAN AVE
CHICAGO, IL 60611

LEAD NO
00116311R3
SALESMAN
N. LITTMAN

DATE
10/14/2013
DRAWN BY
JM

REVIEWED BY
SEG NO

REVISION
R2 11/08/2013 JM

SHEET NO
2 OF 11



City of Chicago



O2014-4878

Office of the City Clerk Document Tracking Sheet

| | |
|---------------------------------|--|
| Meeting Date: | 5/28/2014 |
| Sponsor(s): | Reilly (42) |
| Type: | Ordinance |
| Title: | Grant(s) of privilege in public way for Northwestern University/Chicago Campus - Privilege No. 1112341 |
| Committee(s) Assignment: | Committee on Transportation and Public Way |

ORDINANCE
NORTHWESTERN UNIVERSITY/CHICAGO CAMPUS
Acct. No. 69296 - 5
Permit No. 1112341

Be It Ordained by the City Council of the City of Chicago:

SECTION 1. Permission and authority are hereby given and granted to NORTHWESTERN UNIVERSITY/CHICAGO CAMPUS, upon the terms and subject to the conditions of this ordinance to maintain and use, as now constructed, ten (10) Caisson(s) under the public right-of-way adjacent to its premises known as 321 E. Erie St..

Said Caisson(s) at E. Erie Street measure(s):

- One (1) at nine (9) feet in length, and two (2) feet in width for a total of eighteen (18) square feet.
- One (1) at eight (8) feet in length, and three (3) feet in width for a total of twenty-four (24) square feet.
- One (1) at five (5) feet in length, and two (2) feet in width for a total of ten (10) square feet.
- One (1) at nine (9) feet in length, and three (3) feet in width for a total of twenty-seven (27) square feet.
- One (1) at eight (8) feet in length, and three (3) feet in width for a total of twenty-four (24) square feet.

Said Caisson(s) at E. Ontario measure(s):

- One (1) at nine (9) feet in length, and two (2) feet in width for a total of eighteen (18) square feet.
- One (1) at eight (8) feet in length, and three (3) feet in width for a total of twenty-four (24) square feet.
- One (1) at five (5) feet in length, and two (2) feet in width for a total of ten (10) square feet.
- One (1) at nine (9) feet in length, and three (3) feet in width for a total of twenty-seven (27) square feet.
- One (1) at eight (8) feet in length, and three (3) feet in width for a total of twenty-four (24) square feet.

The location of said privilege shall be as shown on prints kept on file with the Department of Business Affairs and Consumer Protection and the Office of the City Clerk.

Said privilege shall be constructed in accordance with plans and specifications approved by the Department of Planning and Development and Department of Transportation (Office of Underground Coordination).

This grant of privilege in the public way shall be subject to the provisions of Section 10-28-015 and all other required provisions of the Municipal Code of Chicago.

The grantee shall pay to the City of Chicago as compensation for the privilege #1112341 herein granted the sum of four hundred (\$400.00) per annum in advance.

A 25% penalty will be added for payments received after due date.

The permit holder agrees to hold the City of Chicago harmless for any damage, relocation or replacement costs associated with damage, relocation or removal of private property caused by the City performing work in the public way.

Authority herein given and granted for a period of five (5) years from and after 03/31/2014.

Alderman _____

Brendan Reilly 42nd Ward

Handwritten text, possibly a signature or name, located in the lower-left quadrant of the page.

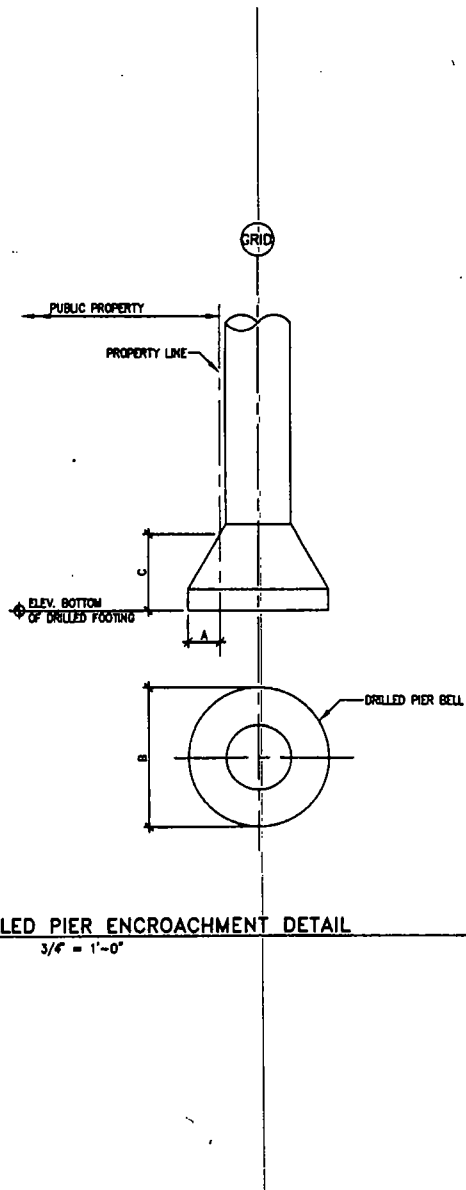

DRILLED PIER ENCRoACHMENT DETAIL

SCALE: 3/4" = 1'-0"

3
S1.2



| DRILLED PIER ENCRoACHMENT SCHEDULE | | | |
|------------------------------------|-----------|-------|--------------|
| ENCRoACHMENT NUMBER | A | B | C |
| 1 | 2'-2 3/4" | 9'-0" | 3'-10 1/8" |
| 2 | 2'-2 3/4" | 8'-0" | 4'-10 1/8" |
| 3 | 0'-8 3/4" | 5'-0" | 3'-11 1/4" |
| 4 | 2'-8 3/4" | 9'-0" | 5'-8 1/2" |
| 5 | 0'-4 1/8" | 8'-0" | 4'-10 1/8" |
| 6 | 1'-8 3/4" | 9'-0" | 3'-8 3/8" |
| 7 | 2'-2 3/4" | 8'-0" | 4'-10 5/16" |
| 8 | 0'-8 3/4" | 5'-0" | 3'-11 15/16" |
| 9 | 2'-8 3/4" | 9'-0" | 5'-8 3/4" |
| 10 | 0'-7 1/2" | 8'-0" | 4'-10 5/16" |

NOTE 1: BELL DIAMETERS HAVE ALREADY BEEN INCREASED 15% OF BEARING AREA, BUT NOT MORE THAN 1'-0" IN WIDTH TO AVOID SPECIAL INSPECTION.

ELEVATIONS ARE REFERENCED TO CITY OF CHICAGO DATUM



City of Chicago



O2014-4879

Office of the City Clerk

Document Tracking Sheet

| | |
|---------------------------------|---|
| Meeting Date: | 5/28/2014 |
| Sponsor(s): | Reilly (42) |
| Type: | Ordinance |
| Title: | Grant(s) of privilege in public way for Walton on the Park LLC |
| Committee(s) Assignment: | Committee on Transportation and Public Way |

ORDINANCE
WALTON ON THE PARK, LLC
Acct. No. 310556 - 3
Permit No. 1112998

Be It Ordained by the City Council of the City of Chicago:

SECTION 1. Permission and authority are hereby given and granted to WALTON ON THE PARK, LLC, upon the terms and subject to the conditions of this ordinance to maintain and use, as now constructed, four (4) Planter(s) on the public right-of-way for beautification purposes adjacent to its premises known as 2 W. Delaware Pl..

Said Planter(s) at W. DELAWARE measure(s):

Two (2) at twenty-two point eight three (22.83) feet in length, and nine point seven five (9.75) feet in width for a total of four hundred forty-five point one nine (445.19) square feet.

Said Planter(s) at DELAWARE PL. measure(s):

Two (2) at twenty-two point one seven (22.17) feet in length, and nine point seven five (9.75) feet in width for a total of four hundred thirty-two point three two (432.32) square feet.

Grantee must allow the required clear and unobstructed space for pedestrian passage at all times per rules and regulations approved by the Department of Transportation.

The location of said privilege shall be as shown on prints kept on file with the Department of Business Affairs and Consumer Protection and the Office of the City Clerk.

Said privilege shall be constructed in accordance with plans and specifications approved by the Department of Planning and Development and Department of Transportation (Division of Project Development).

This grant of privilege in the public way shall be subject to the provisions of Section 10-28-015 and all other required provisions of the Municipal Code of Chicago.

The grantee shall pay to the City of Chicago as compensation for the privilege #1112998 herein granted the sum of zero (\$0.00) per annum in advance.

A 25% penalty will be added for payments received after due date.

The permit holder agrees to hold the City of Chicago harmless for any damage, relocation or replacement costs associated with damage, relocation or removal of private property caused by the City performing work in the public way.

Authority herein given and granted for a period of five (5) years from and after 12/17/2013.

Alderman _____

Brendan Reilly 42nd Ward

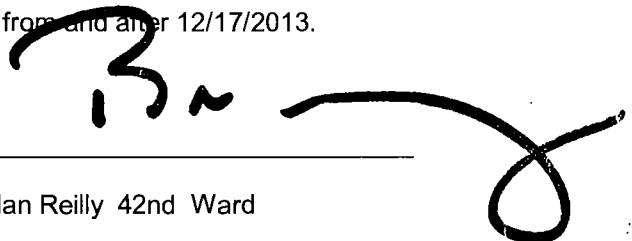
A large, stylized handwritten signature in black ink, appearing to read 'B. Reilly', is written over the signature line and extends to the right.

Handwritten scribbles and marks, possibly including the number '1'.

WALTON ON THE PARK SOUTH CONDOMINIUMS 2 WEST DELAWARE PLACE CHICAGO, ILLINOIS

GRAPHIC SCALE

LEGAL DESCRIPTION
FOR DEED, CONVEYANCE, PLANS AND MAPS

SOUTH LINE OF S. 100' WIDE ST.

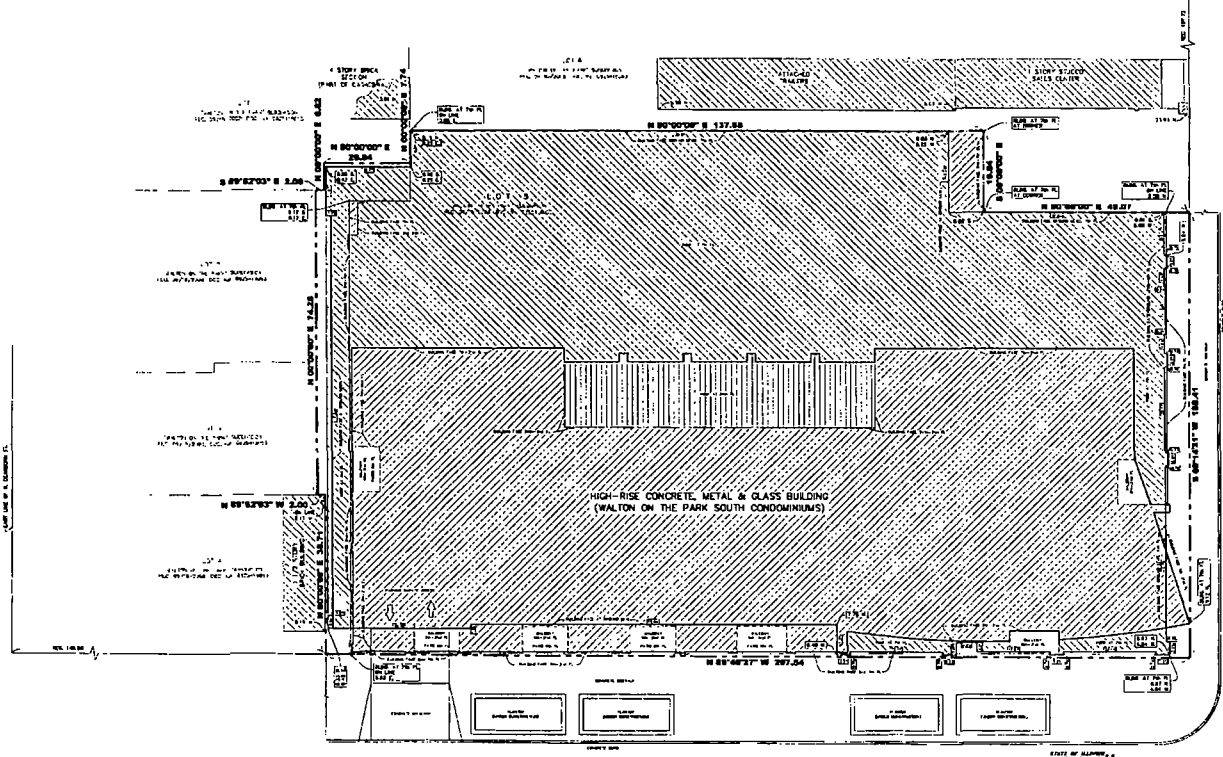

REVISIONS:

1. TO CORRECT THE AREA OF THE BUILDING FOOTPRINT TO BE 10,000 SQUARE FEET AS SHOWN ON THE PLAN AND TO CORRECT THE AREA OF THE COMMON AREAS TO BE 1,000 SQUARE FEET AS SHOWN ON THE PLAN.

2. TO CORRECT THE AREA OF THE BUILDING FOOTPRINT TO BE 10,000 SQUARE FEET AS SHOWN ON THE PLAN AND TO CORRECT THE AREA OF THE COMMON AREAS TO BE 1,000 SQUARE FEET AS SHOWN ON THE PLAN.

3. TO CORRECT THE AREA OF THE BUILDING FOOTPRINT TO BE 10,000 SQUARE FEET AS SHOWN ON THE PLAN AND TO CORRECT THE AREA OF THE COMMON AREAS TO BE 1,000 SQUARE FEET AS SHOWN ON THE PLAN.

4. TO CORRECT THE AREA OF THE BUILDING FOOTPRINT TO BE 10,000 SQUARE FEET AS SHOWN ON THE PLAN AND TO CORRECT THE AREA OF THE COMMON AREAS TO BE 1,000 SQUARE FEET AS SHOWN ON THE PLAN.

5. TO CORRECT THE AREA OF THE BUILDING FOOTPRINT TO BE 10,000 SQUARE FEET AS SHOWN ON THE PLAN AND TO CORRECT THE AREA OF THE COMMON AREAS TO BE 1,000 SQUARE FEET AS SHOWN ON THE PLAN.

N. STATE ST.
CHICAGO, ILLINOIS

N. DELAWARE PL.
CHICAGO, ILLINOIS

LEGEND

INDICATES QUANTITIES OF THE PLAN

1. AREA OF THE BUILDING FOOTPRINT

2. AREA OF THE COMMON AREAS

3. AREA OF THE SETBACK AREAS

4. AREA OF THE DRIVEWAYS

5. AREA OF THE PARKING AREAS

McTIGUE & SPIEWAK, INC.
PROFESSIONAL ARCHITECTS, PLANNERS AND ENGINEERS, P.C.
CHICAGO, ILLINOIS

NOTICE:

THIS PLAN IS A PROFESSIONAL DESIGN FOR THE CONSTRUCTION OF THE BUILDING SHOWN THEREON. IT IS THE RESPONSIBILITY OF THE ARCHITECT TO VERIFY THE ACCURACY OF THE DATA PROVIDED TO HIM BY THE CLIENT AND TO BE RESPONSIBLE FOR THE DESIGN OF THE BUILDING AND THE COMMON AREAS. THE ARCHITECT DOES NOT WARRANT THE ACCURACY OF THE DATA PROVIDED TO HIM BY THE CLIENT OR THE DESIGN OF THE BUILDING OR THE COMMON AREAS.

STATE OF ILLINOIS
COUNTY OF COOK

I, **McTigue & Spiewak, Inc.**, a corporation organized under the laws of the State of Illinois, do hereby certify that the above is a true and correct copy of the original plan as the same appears on file in my office.

WITNESSED my hand and the seal of my office this **10th** day of **February**, 20**10**.

McTigue & Spiewak, Inc.
Professional Architect, Planner and Engineer, P.C.
Chicago, Illinois

PLAT OF SURVEY
PAGE 1 OF 40
EXHIBIT D



City of Chicago



O2014-4880

Office of the City Clerk

Document Tracking Sheet

| | |
|---------------------------------|--|
| Meeting Date: | 5/28/2014 |
| Sponsor(s): | Reilly (42) |
| Type: | Ordinance |
| Title: | Grant(s) of privilege in public way for 131 S Dearborn LLC |
| Committee(s) Assignment: | Committee on Transportation and Public Way |

ORDINANCE
131 S. DEARBORN LLC
Acct. No. 338788 - 1
Permit No. 1112003

Be It Ordained by the City Council of the City of Chicago:

SECTION 1. Permission and authority are hereby given and granted to 131 S. DEARBORN LLC, upon the terms and subject to the conditions of this ordinance to maintain and use, as now constructed, four (4) Vault(s) under the public right-of-way adjacent to its premises known as 131 S. Dearborn St..

Said Vault(s) at S. State Street measure(s):

One (1) at two hundred point eight three (200.83) feet in length, and seventeen point eight three (17.83) feet in width for a total of three thousand five hundred eighty point eight (3580.8) square feet.

Said Vault(s) at W. Adams Street measure(s):

One (1) at three hundred fifty-one point four two (351.42) feet in length, and twelve point five (12.5) feet in width for a total of four thousand three hundred ninety-two point seven five (4392.75) square feet.

Said Vault(s) at W. Marble Place measure(s):

One (1) at one hundred sixty-seven point zero eight (167.08) feet in length, and eight point six seven (8.67) feet in width for a total of one thousand four hundred forty-eight point five eight (1448.58) square feet.

Said Vault(s) at S. Dearborn Street measure(s):

One (1) at two hundred eight point nine two (208.92) feet in length, and twelve point five eight (12.58) feet in width for a total of two thousand six hundred twenty-eight point two one (2628.21) square feet.

Existing vaults are used for office space and storage.

The location of said privilege shall be as shown on prints kept on file with the Department of Business Affairs and Consumer Protection and the Office of the City Clerk.

Said privilege shall be constructed in accordance with plans and specifications approved by the Department of Transportation (Office of Underground Coordination).

This grant of privilege in the public way shall be subject to the provisions of Section 10-28-015 and all other required provisions of the Municipal Code of Chicago.

The grantee shall pay to the City of Chicago as compensation for the privilege #1112003 herein granted the sum of seventy-four thousand four hundred forty-seven (\$74,447.00) per annum in advance.

A 25% penalty will be added for payments received after due date.

The permit holder agrees to hold the City of Chicago harmless for any damage, relocation or replacement costs associated with damage, relocation or removal of private property caused by the City performing work in the public way.

Authority herein given and granted for a period of five (5) years from and after 01/26/2014.

Alderman _____

Brendan Reilly 42nd Ward

Handwritten scribbles or marks at the bottom left of the page.

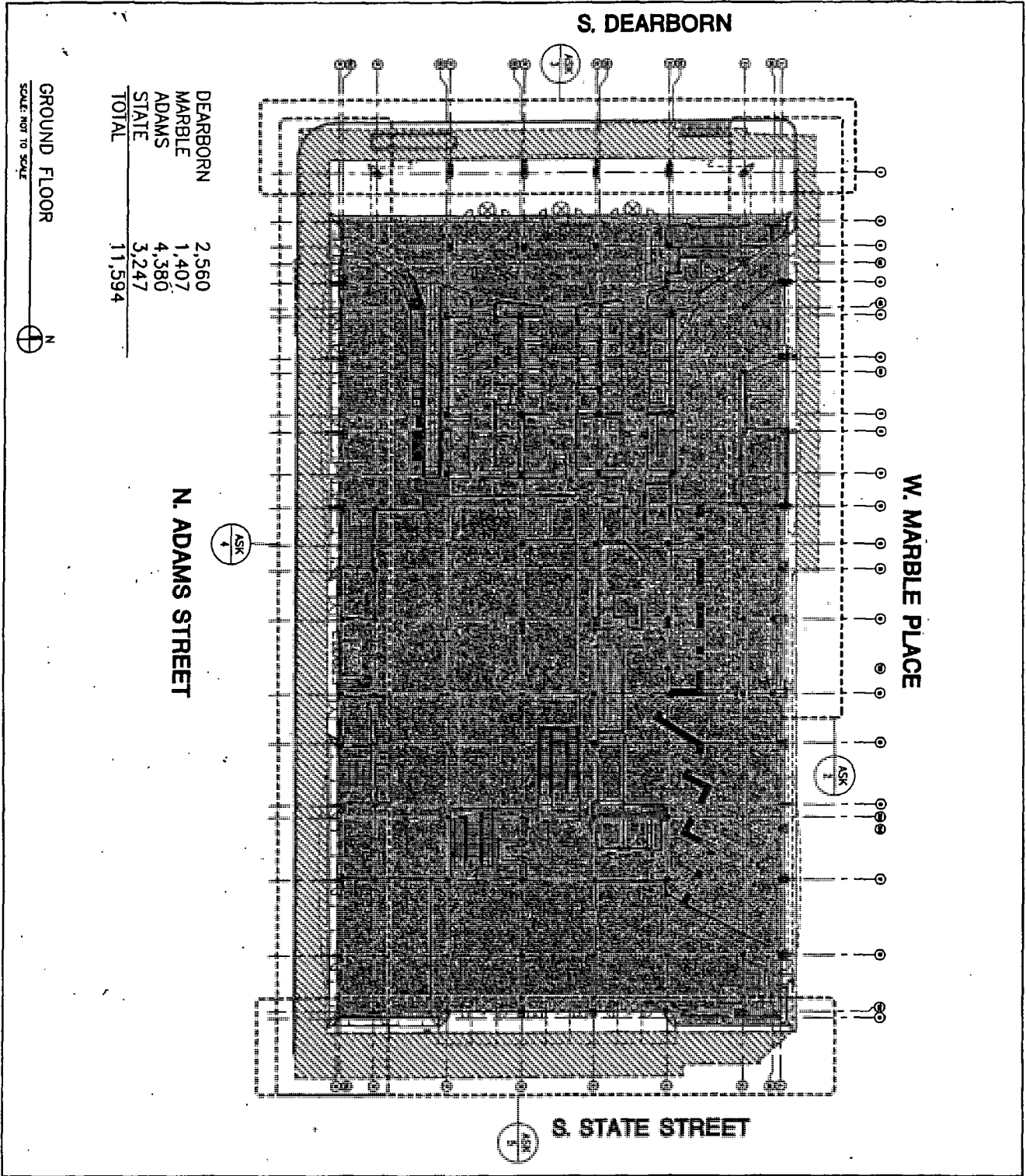

DE STEFANO + PARTNERS
 DeStefano and Partners, Ltd.
 445 East Illinois Street
 Chicago, Illinois 60611

Architecture
 Planning
 Interior Design

**131 SOUTH DEARBORN
 CHICAGO, IL**

| | | | | |
|---------|------------|---------------|------|--------------------|
| Date | 10.02.2008 | Revisions No. | Date | ASK 001 |
| Drawn | LR | | | |
| Checked | CS | | | |
| Job No. | | | | |



City of Chicago



02014-4633

Office of the City Clerk

Document Tracking Sheet

| | |
|---------------------------------|--|
| Meeting Date: | 5/28/2014 |
| Sponsor(s): | Smith (43) |
| Type: | Ordinance |
| Title: | Grant(s) of privilege in public way for David Young-Jeff Peters - planter |
| Committee(s) Assignment: | Committee on Transportation and Public Way |

ORDINANCE
DAVID YOUNG-JEFF PETERS
Acct. No. 389677 - 1
Permit No. 1112498

Be It Ordained by the City Council of the City of Chicago:

SECTION 1. Permission and authority are hereby given and granted to DAVID YOUNG-JEFF PETERS, upon the terms and subject to the conditions of this ordinance to construct, install, maintain and use one (1) Planter(s) on the public right-of-way for beautification purposes adjacent to its premises known as 1847 N. Orleans St..

Said Planter(s) at N. Orleans Street measure(s):

One (1) at twenty-four point four (24.4) feet in length, and nine (9) feet in width for a total of two hundred nineteen point six (219.6) square feet.

Grantee must allow the required clear and unobstructed space for pedestrian passage at all times per rules and regulations approved by the Department of Transportation.

The location of said privilege shall be as shown on prints kept on file with the Department of Business Affairs and Consumer Protection and the Office of the City Clerk.

Said privilege shall be constructed in accordance with plans and specifications approved by the Department of Planning and Development and Department of Transportation (Division of Project Development).

This grant of privilege in the public way shall be subject to the provisions of Section 10-28-015 and all other required provisions of the Municipal Code of Chicago.

The grantee shall pay to the City of Chicago as compensation for the privilege #1112498 herein granted the sum of zero (\$0.00) per annum in advance.

A 25% penalty will be added for payments received after due date.

The permit holder agrees to hold the City of Chicago harmless for any damage, relocation or replacement costs associated with damage, relocation or removal of private property caused by the City performing work in the public way.

Authority herein given and granted for a period of five (5) years from and after Date of Passage.

Alderman 

Michele Smith 43rd Ward

2 of 2

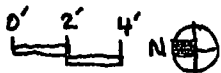
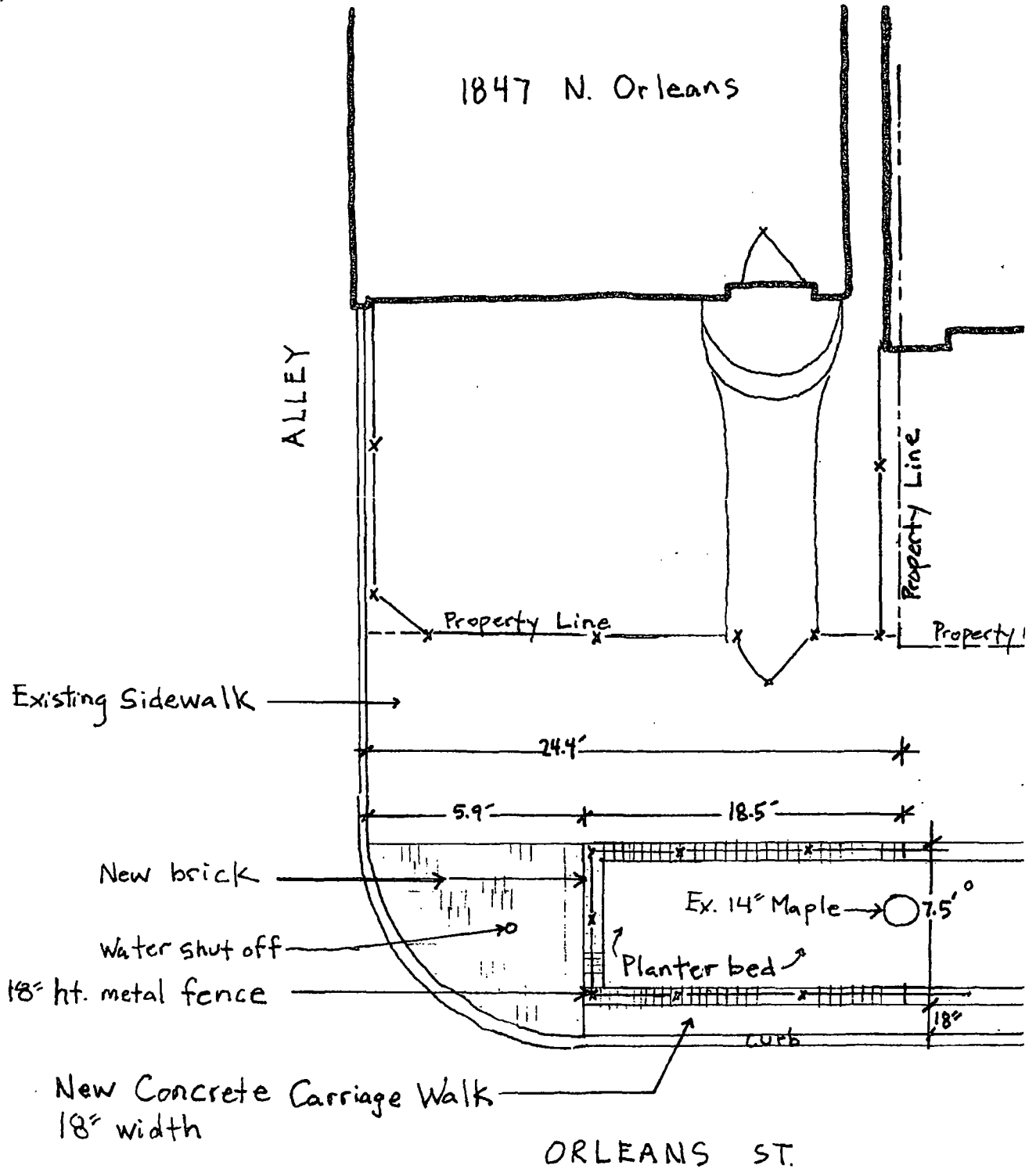

Planter Bed, Fence & Brick Plan

Young/Peters residence
1847 N. Orleans
Chicago, IL



City of Chicago



O2014-4653

Office of the City Clerk

Document Tracking Sheet

| | |
|---------------------------------|--|
| Meeting Date: | 5/28/2014 |
| Sponsor(s): | Smith (43) |
| Type: | Ordinance |
| Title: | Grant(s) of privilege in public way for David Young-Jeff Peters - fence |
| Committee(s) Assignment: | Committee on Transportation and Public Way |

ORDINANCE
DAVID YOUNG-JEFF PETERS
Acct. No. 389677 - 1
Permit No. 1112499

Be It Ordained by the City Council of the City of Chicago:

SECTION 1. Permission and authority are hereby given and granted to DAVID YOUNG-JEFF PETERS, upon the terms and subject to the conditions of this ordinance to construct, install, maintain and use one (1) Fence(s) on the public right-of-way for beautification purposes adjacent to its premises known as 1847 N. Orleans St..

Said Fence(s) at N. Orleans Street measure(s):

One (1) at sixty-six point eight (66.8) feet in length, and one (1) foot in width for a total of sixty-six point eight (66.8) square feet. Said fencing shall be eighteen (18) inches in height.

The location of said privilege shall be as shown on prints kept on file with the Department of Business Affairs and Consumer Protection and the Office of the City Clerk.

Said privilege shall be constructed in accordance with plans and specifications approved by the Department of Transportation (Division of Project Development).

This grant of privilege in the public way shall be subject to the provisions of Section 10-28-015 and all other required provisions of the Municipal Code of Chicago.

The grantee shall pay to the City of Chicago as compensation for the privilege #1112499 herein granted the sum of zero (\$.00) per annum in advance.

A 25% penalty will be added for payments received after due date.

The permit holder agrees to hold the City of Chicago harmless for any damage, relocation or replacement costs associated with damage, relocation or removal of private property caused by the City performing work in the public way.

Authority herein given and granted for a period of five (5) years from and after Date of Passage.

Alderman

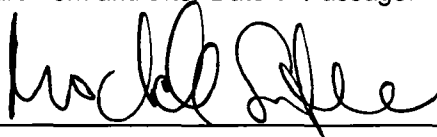

Michele Smith 43rd Ward

2 of 2

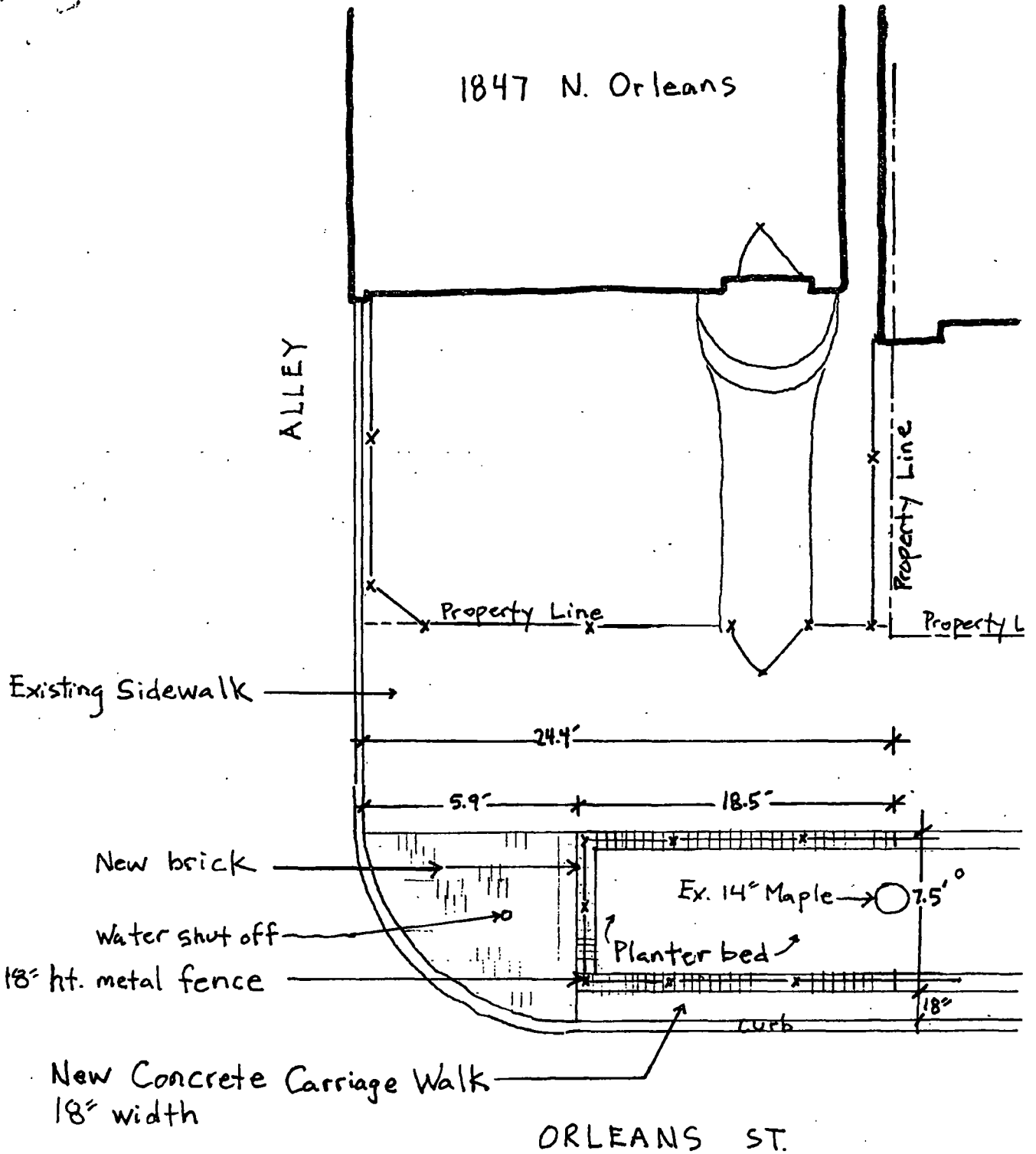

Planter Bed, Fence & Brick Plan

Young/Peters residence
1847 N. Orleans
Chicago, IL



City of Chicago



O2014-4655

Office of the City Clerk

Document Tracking Sheet

| | |
|---------------------------------|---|
| Meeting Date: | 5/28/2014 |
| Sponsor(s): | Smith (43) |
| Type: | Ordinance |
| Title: | Grant(s) of privilege in public way for Great Clips |
| Committee(s) Assignment: | Committee on Transportation and Public Way |

ORDINANCE
GREAT CLIPS
Acct. No. 64581 - 5
Permit No. 1111276

Be It Ordained by the City Council of the City of Chicago:

SECTION 1. Permission and authority are hereby given and granted to GREAT CLIPS, upon the terms and subject to the conditions of this ordinance to maintain and use one (1) sign(s) projecting over the public right-of-way attached to its premises known as 2506 N. Clark St..

Said sign structure(s) measures as follows; along N. Clark Street:
One (1) at fifteen (15) feet in length, two point five (2.5) feet in height and ten (10) feet above grade level.

The location of said privilege shall be as shown on prints kept on file with the Department of Business Affairs and Consumer Protection and the Office of the City Clerk.

Said privilege shall be constructed in accordance with plans and specifications approved by the Department of Transportation (Division of Project Development) and Zoning Department - Signs.

This grant of privilege in the public way shall be subject to the provisions of Section 10-28-015 and all other required provisions of the Municipal Code of Chicago.

The grantee shall pay to the City of Chicago as compensation for the privilege #1111276 herein granted the sum of three hundred (\$300.00) per annum in advance.

A 25% penalty will be added for payments received after due date.

The permit holder agrees to hold the City of Chicago harmless for any damage, relocation or replacement costs associated with damage, relocation or removal of private property caused by the City performing work in the public way.

Authority herein given and granted for a period of five (5) years from and after Date of Passage.

Alderman 

Michele Smith 43rd Ward

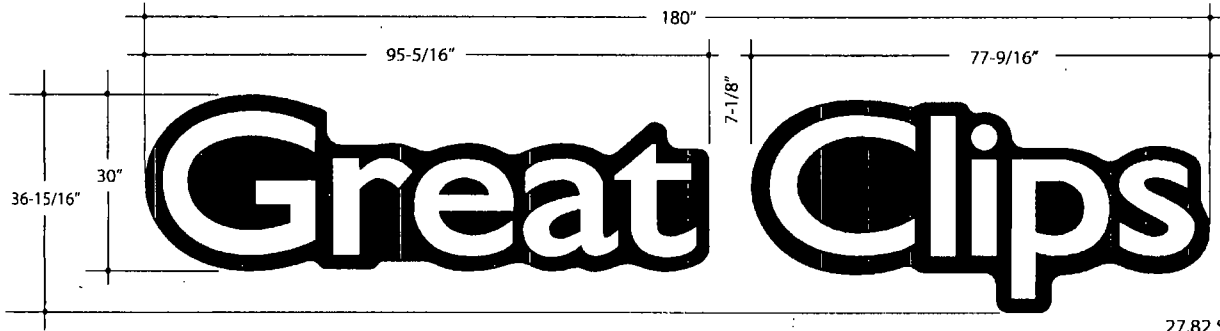

27.82 SQ.FT.



PART #E003178B
W/O RACEWAY

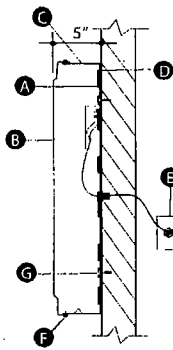

| | | |
|---------------------------|-----------|----------------------------|
| A LED ILLUMINATION | COLOR | WHITE |
| B FACE | THICKNESS | .117 FORMED POLY |
| | COLOR | WHITE & BLACK |
| C ALUM. RETURN | DEPTH | 5" |
| | COLOR | BLACK (INTERIOR-WHITE) |
| | GAUGE | .040 |
| D ALUM. BACK | GAUGE | .063 |
| E POWER SUPPLY | AMPS | 6.4 |
| | TYPE | 96W (2 REQUIRED) |
| F SCREWS | TYPE | #4-1/2" PHILLIPS HEAD |
| G MOUNTING | INTERNAL | 1/4" RIVNUT/FENDER WASHERS |
| | EXTERNAL | 1/4" THREADED ROD |

| | | | |
|--|--|--|--|
| | | <small>DISCLAIMER: Renderings are for guide purposes only and not intended for actual construction dimensions. For workload requirements, actual dimensions and including detail, please refer to engineering specifications and install drawings. These drawings and designs are the exclusive property of Everbrite LLC. Use of, or duplication in any manner without express written permission of Everbrite LLC is prohibited.</small> | |
| Customer: GREAT CLIPS | | Description: 30" SIGNATURE SIGN WITHOUT RACEWAY | |
| Project No: 302544 | | Scale: AS NOTED | |
| Date: 9/27/13 | | Drawn By: DB | |
| Location & Site No: Chicago, IL SITE - GRCLPCLARK | | Revised: | |
| Customer Approval: Graphics and colors on file will be used unless otherwise specified by customer. Please review drawing carefully. By signing below, you agree to graphics as shown above, and to location of sign as shown. Please return signed copy back to Everbrite. | | _____ CUSTOMER SIGNATURE | |
| _____ LANDLORD SIGNATURE | | _____ DATE | |



City of Chicago



O2014-4656

Office of the City Clerk

Document Tracking Sheet

| | |
|---------------------------------|---|
| Meeting Date: | 5/28/2014 |
| Sponsor(s): | Smith (43) |
| Type: | Ordinance |
| Title: | Grant(s) of privilege in public way for New Balance Chicago |
| Committee(s) Assignment: | Committee on Transportation and Public Way |

ORDINANCE
NEW BALANCE CHICAGO
Acct. No. 35381 - 1
Permit No. 1112980

Be It Ordained by the City Council of the City of Chicago:

SECTION 1. Permission and authority are hereby given and granted to NEW BALANCE CHICAGO, upon the terms and subject to the conditions of this ordinance to maintain and use four (4) sign(s) projecting over the public right-of-way attached to its premises known as 2369 N. Clark St..

Said sign structure(s) measures as follows; along n. clark st.:

One (1) at twelve (12) feet in length, two point five (2.5) feet in height and ten (10) feet above grade level.

Said sign structure(s) measures as follows; along n. clark st.:

One (1) at twelve (12) feet in length, two point five (2.5) feet in height and ten (10) feet above grade level.

Said sign structure(s) measures as follows; along n. clark st.:

One (1) at six (6) feet in length, five (5) feet in height and ten (10) feet above grade level.

Said sign structure(s) measures as follows; along n. clark st.:

One (1) at six (6) feet in length, five (5) feet in height and ten (10) feet above grade level.

The location of said privilege shall be as shown on prints kept on file with the Department of Business Affairs and Consumer Protection and the Office of the City Clerk.

Said privilege shall be constructed in accordance with plans and specifications approved by the Department of Transportation (Division of Project Development) and Zoning Department - Signs.

This grant of privilege in the public way shall be subject to the provisions of Section 10-28-015 and all other required provisions of the Municipal Code of Chicago.

The grantee shall pay to the City of Chicago as compensation for the privilege #1112980 herein granted the sum of one thousand two hundred (\$1,200.00) per annum in advance.

A 25% penalty will be added for payments received after due date.

The permit holder agrees to hold the City of Chicago harmless for any damage, relocation or replacement costs associated with damage, relocation or removal of private property caused by the City performing work in the public way.

Authority herein given and granted for a period of five (5) years from and after 09/10/2013.

Alderman _____



Michele Smith 43rd Ward

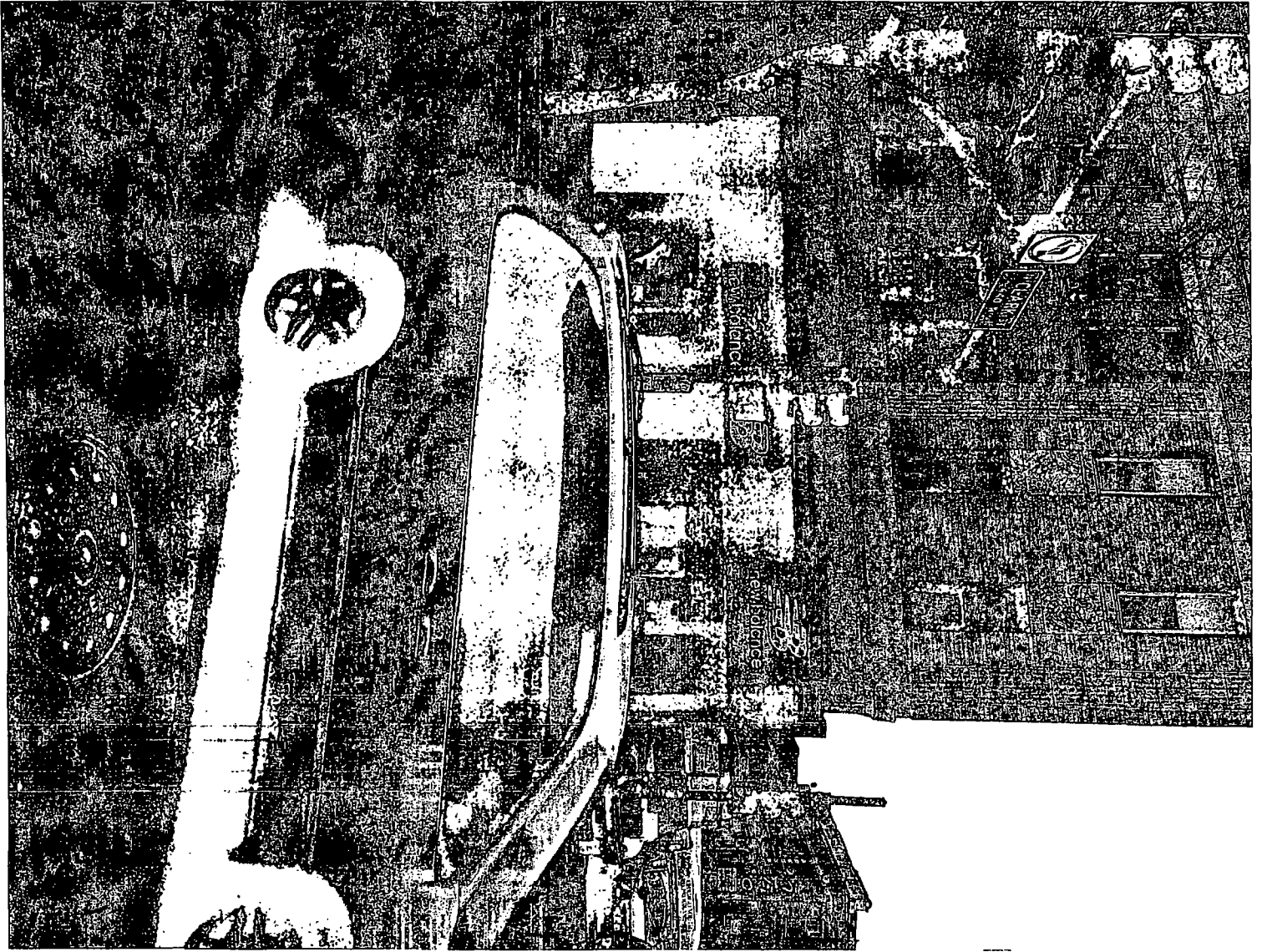



City of Chicago



O2014-4657

Office of the City Clerk

Document Tracking Sheet

| | |
|---------------------------------|--|
| Meeting Date: | 5/28/2014 |
| Sponsor(s): | Smith (43) |
| Type: | Ordinance |
| Title: | Grant(s) of privilege in public way for Public Storage |
| Committee(s) Assignment: | Committee on Transportation and Public Way |

ORDINANCE
PUBLIC STORAGE
Acct. No. 211743 - 13
Permit No. 1112852

Be It Ordained by the City Council of the City of Chicago:

SECTION 1. Permission and authority are hereby given and granted to PUBLIC STORAGE, upon the terms and subject to the conditions of this ordinance to maintain and use one (1) sign(s) projecting over the public right-of-way attached to its premises known as 1129 N. Wells St..

Said sign structure(s) measures as follows; along N. Wells Street:

One (1) at twelve (12) feet in length, seven (7) feet in height and forty-one point five (41.5) feet above grade level.

The location of said privilege shall be as shown on prints kept on file with the Department of Business Affairs and Consumer Protection and the Office of the City Clerk.

Said privilege shall be constructed in accordance with plans and specifications approved by the Department of Transportation (Division of Project Development) and Zoning Department - Signs.

This grant of privilege in the public way shall be subject to the provisions of Section 10-28-015 and all other required provisions of the Municipal Code of Chicago.

The grantee shall pay to the City of Chicago as compensation for the privilege #1112852 herein granted the sum of three hundred (\$300.00) per annum in advance.

A 25% penalty will be added for payments received after due date.

The permit holder agrees to hold the City of Chicago harmless for any damage, relocation or replacement costs associated with damage, relocation or removal of private property caused by the City performing work in the public way.

Authority herein given and granted for a period of five (5) years from and after 01/13/2014.

Alderman 

Michele Smith 43rd Ward





City of Chicago



O2014-4788

Office of the City Clerk

Document Tracking Sheet

| | |
|---------------------------------|---|
| Meeting Date: | 5/28/2014 |
| Sponsor(s): | Tunney (44) |
| Type: | Ordinance |
| Title: | Grant(s) of privilege in public way for Exedus II |
| Committee(s) Assignment: | Committee on Transportation and Public Way |

ORDINANCE
EXEDUS II
Acct. No. 28217 - 1
Permit No. 1112815

Be It Ordained by the City Council of the City of Chicago:

SECTION 1. Permission and authority are hereby given and granted to EXEDUS II, upon the terms and subject to the conditions of this ordinance to maintain and use one (1) sign(s) projecting over the public right-of-way attached to its premises known as 3477 N. Clark St..

Said sign structure(s) measures as follows; along N. CLARK ST:
One (1) at four (4) feet in length, five (5) feet in height and ten point six seven (10.67) feet above grade level.

The location of said privilege shall be as shown on prints kept on file with the Department of Business Affairs and Consumer Protection and the Office of the City Clerk.

Said privilege shall be constructed in accordance with plans and specifications approved by the Department of Transportation (Division of Project Development) and Zoning Department - Signs.

This grant of privilege in the public way shall be subject to the provisions of Section 10-28-015 and all other required provisions of the Municipal Code of Chicago.

The grantee shall pay to the City of Chicago as compensation for the privilege #1112815 herein granted the sum of one hundred (\$100.00) per annum in advance.

A 25% penalty will be added for payments received after due date.

The permit holder agrees to hold the City of Chicago harmless for any damage, relocation or replacement costs associated with damage, relocation or removal of private property caused by the City performing work in the public way.

Authority herein given and granted for a period of five (5) years from and after 05/13/2014.

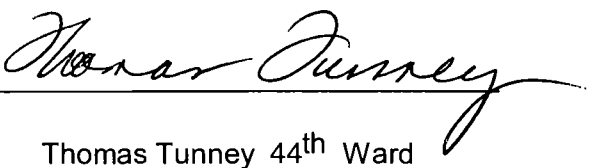
Alderman 
Thomas Tunney 44th Ward

METAL FRAME
PLASTIC CASING

3477 N CLARK ST

HEIGHT
5'

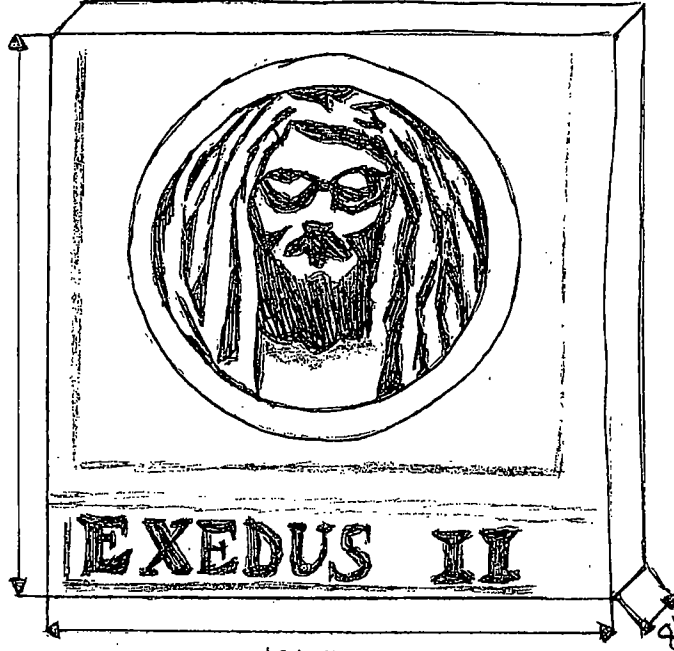

LENGTH
4'

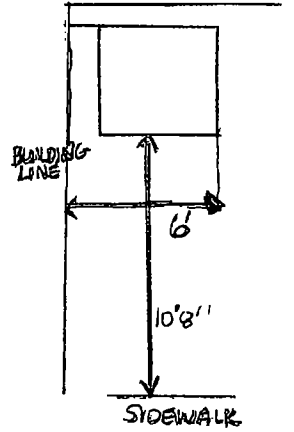



City of Chicago



O2014-4797

Office of the City Clerk

Document Tracking Sheet

| | |
|---------------------------------|---|
| Meeting Date: | 5/28/2014 |
| Sponsor(s): | Tunney (44) |
| Type: | Ordinance |
| Title: | Grant(s) of privilege in public way for Teavana No. 21920 |
| Committee(s) Assignment: | Committee on Transportation and Public Way |

ORDINANCE
Teavana #21920
Acct. No. 63414 - 164
Permit No. 1111191

Be It Ordained by the City Council of the City of Chicago:

SECTION 1. Permission and authority are hereby given and granted to Teavana #21920, upon the terms and subject to the conditions of this ordinance to maintain and use two (2) sign(s) projecting over the public right-of-way attached to its premises known as 3428 N. Southport Ave..

Said sign structure(s) measures as follows; along N. Southport Avenue:

One (1) at nine point one seven (9.17) feet in length, two point one seven (2.17) feet in height and thirteen (13) feet above grade level.

One (1) at one (1) foot in length, one (1) foot in height and nine (9) feet above grade level.

The location of said privilege shall be as shown on prints kept on file with the Department of Business Affairs and Consumer Protection and the Office of the City Clerk.

Said privilege shall be constructed in accordance with plans and specifications approved by the Department of Transportation (Division of Project Development) and Zoning Department - Signs.

This grant of privilege in the public way shall be subject to the provisions of Section 10-28-015 and all other required provisions of the Municipal Code of Chicago.

The grantee shall pay to the City of Chicago as compensation for the privilege #1111191 herein granted the sum of one hundred (\$100.00) per annum in advance.

A 25% penalty will be added for payments received after due date.

The permit holder agrees to hold the City of Chicago harmless for any damage, relocation or replacement costs associated with damage, relocation or removal of private property caused by the City performing work in the public way.

Authority herein given and granted for a period of five (5) years from and after Date of Passage.

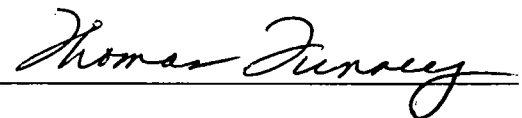
Alderman 

Thomas Tunney 44th Ward

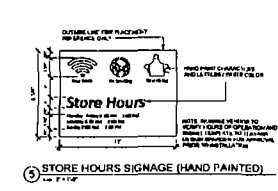
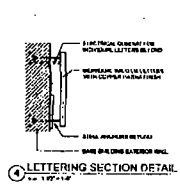
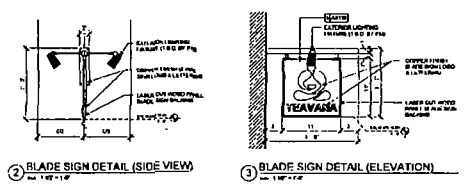

| NO. | DESCRIPTION | QUANTITY | UNIT | REMARKS |
|-----|--------------------------|----------|------|---------|
| 1 | BLADE SIGN (SIDE VIEW) | 1 | EA | |
| 2 | BLADE SIGN (ELEVATION) | 1 | EA | |
| 3 | LETTERING SECTION DETAIL | 1 | EA | |
| 4 | STORE HOURS SIGNAGE | 1 | EA | |

EXTERIOR ELEVATION NOTES

1. GENERAL CONTRACTOR TO PROVIDE ALL MATERIALS AND FINISHES. PROVIDER TO BE RESPONSIBLE FOR ALL MATERIALS AND FINISHES. PROVIDER TO BE RESPONSIBLE FOR ALL MATERIALS AND FINISHES. PROVIDER TO BE RESPONSIBLE FOR ALL MATERIALS AND FINISHES.
2. GENERAL CONTRACTOR TO PROVIDE ALL MATERIALS AND FINISHES. PROVIDER TO BE RESPONSIBLE FOR ALL MATERIALS AND FINISHES. PROVIDER TO BE RESPONSIBLE FOR ALL MATERIALS AND FINISHES.
3. GENERAL CONTRACTOR TO PROVIDE ALL MATERIALS AND FINISHES. PROVIDER TO BE RESPONSIBLE FOR ALL MATERIALS AND FINISHES. PROVIDER TO BE RESPONSIBLE FOR ALL MATERIALS AND FINISHES.

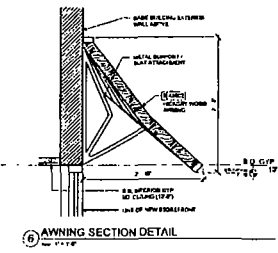

SHEET NOTES

1. PROVIDER TO BE RESPONSIBLE FOR ALL MATERIALS AND FINISHES. PROVIDER TO BE RESPONSIBLE FOR ALL MATERIALS AND FINISHES. PROVIDER TO BE RESPONSIBLE FOR ALL MATERIALS AND FINISHES.
2. PROVIDER TO BE RESPONSIBLE FOR ALL MATERIALS AND FINISHES. PROVIDER TO BE RESPONSIBLE FOR ALL MATERIALS AND FINISHES. PROVIDER TO BE RESPONSIBLE FOR ALL MATERIALS AND FINISHES.
3. PROVIDER TO BE RESPONSIBLE FOR ALL MATERIALS AND FINISHES. PROVIDER TO BE RESPONSIBLE FOR ALL MATERIALS AND FINISHES. PROVIDER TO BE RESPONSIBLE FOR ALL MATERIALS AND FINISHES.

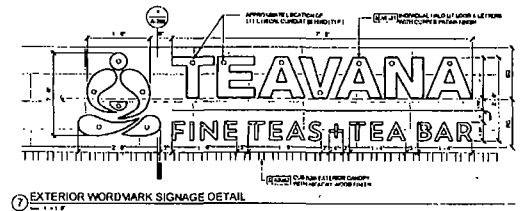
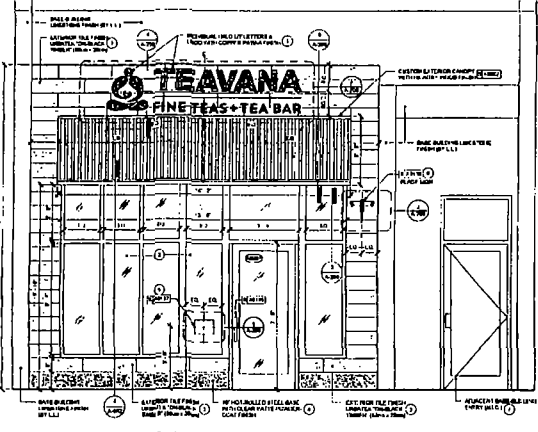



TEAVANA
201 West Avenue Road
Scottsdale, Arizona 85258
(480) 344-1575

ITPIGI
INTERNATIONAL TRADE PROMOTION INSTITUTE
1111 North Dearborn Street
Chicago, IL 60610
(312) 467-1111

Seal of the City of Chicago
OFFICE OF THE CITY CLERK
311 N. LAKE STREET
CHICAGO, IL 60601
(312) 321-4000

Project Name: **Southport Chicago**
Address: **Southport Ave Chicago, IL 60637**

Sheet #: **3183B**
Project #: **01388-081**
Date: **10/20/08**
Scale: **AS SHOWN**
City Engineer: **Timothy J. Ryan**
City Seal: **178**
Contractor: **James Lee**

Scale: **1/8" = 1'-0"**
EXTERIOR ELEVATIONS

Sheet Number: **A-200**



City of Chicago



O2014-4812

Office of the City Clerk

Document Tracking Sheet

Meeting Date: 5/28/2014

Sponsor(s): Tunney (44)

Type: Ordinance

Title: Grant(s) of privilege in public way for Annoyance
Productions

Committee(s) Assignment: Committee on Transportation and Public Way

ORDINANCE
ANNOYANCE PRODUCTIONS
Acct. No. 278216 - 3
Permit No. 1110755

Be It Ordained by the City Council of the City of Chicago:

SECTION 1. Permission and authority are hereby given and granted to ANNOYANCE PRODUCTIONS, upon the terms and subject to the conditions of this ordinance to maintain and use one (1) sign(s) projecting over the public right-of-way attached to its premises known as 851-53 W. Belmont Ave..

Said sign structure(s) measures as follows; along W Belmont Ave:
One (1) at twenty-five (25) feet in length, four (4) feet in height and twenty-three (23) feet above grade level.

The location of said privilege shall be as shown on prints kept on file with the Department of Business Affairs and Consumer Protection and the Office of the City Clerk.

Said privilege shall be constructed in accordance with plans and specifications approved by the Department of Transportation (Division of Project Development) and Zoning Department - Signs.

This grant of privilege in the public way shall be subject to the provisions of Section 10-28-015 and all other required provisions of the Municipal Code of Chicago.

The grantee shall pay to the City of Chicago as compensation for the privilege #1110755 herein granted the sum of three hundred (\$300.00) per annum in advance.

A 25% penalty will be added for payments received after due date.

The permit holder agrees to hold the City of Chicago harmless for any damage, relocation or replacement costs associated with damage, relocation or removal of private property caused by the City performing work in the public way.

Authority herein given and granted for a period of five (5) years from and after Date of Passage.

Alderman

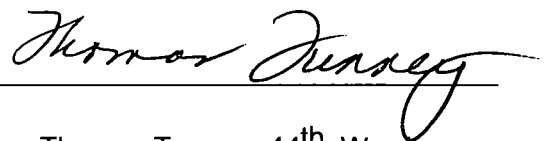

Thomas Tunney 44th Ward



4'x 25' SINGLE FACE SIGN

3'-7" x 7' NEON AND VINYL GRAPHIC
 9" DOUBLE TUBE RED NEON LETTERS
 WHITE NEON OUTLINE

7"/11.5" SINGLE TUBE
 PINK NEON TEXT

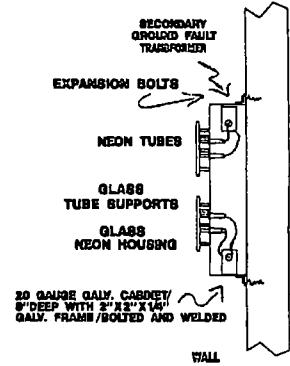
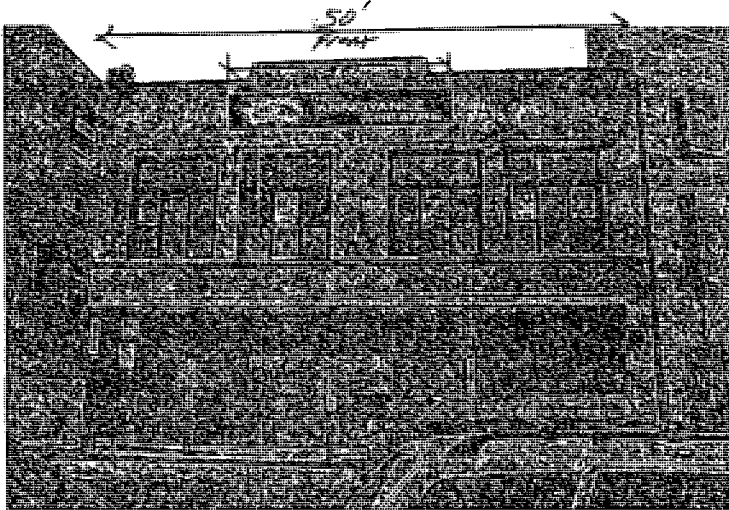

| | |
|--------------------------------|--------------|
| Best Neon Sign | |
| SCALE 3/8"=1'0" SK NO. ANNOY2 | |
| CUSTOMER THE ANNOYANCE THEATRE | |
| JOB ADDRESS | |
| CITY CHICAGO | STATE IL |
| ARTIST TS | DATE 1/22/14 |
| SALES APPROVED | DATE |
| CUSTOMER APPROVAL: | |

By signing the approval box on this sketch, I understand that I am accepting all aspects of this drawing. This includes artwork, specifications, dimensions, spelling and any other representations herein. I also understand that when reproductions on this sketch are appropriate, and they will match manufactured product exactly.



City of Chicago



O2014-4814

Office of the City Clerk

Document Tracking Sheet

| | |
|---------------------------------|--|
| Meeting Date: | 5/28/2014 |
| Sponsor(s): | Tunney (44) |
| Type: | Ordinance |
| Title: | Grant(s) of privilege in public way for Bel-Port Food & Liquor, Inc. |
| Committee(s) Assignment: | Committee on Transportation and Public Way |

ORDINANCE
BEL-PORT FOOD & LIQUOR INC
Acct. No. 28249 - 1
Permit No. 1113010

Be It Ordained by the City Council of the City of Chicago:

SECTION 1. Permission and authority are hereby given and granted to BEL-PORT FOOD & LIQUOR INC, upon the terms and subject to the conditions of this ordinance to maintain and use two (2) sign(s) projecting over the public right-of-way attached to its premises known as 1362 W. Belmont Ave..

Said sign structure(s) measures as follows; along W. BELMONT:
One (1) at two (2) feet in length, six (6) feet in height and nine (9) feet above grade level.

Said sign structure(s) measures as follows; along N. SOUTHPORT:
One (1) at four (4) feet in length, four point three three (4.33) feet in height and nine (9) feet above grade level.

The location of said privilege shall be as shown on prints kept on file with the Department of Business Affairs and Consumer Protection and the Office of the City Clerk.

Said privilege shall be constructed in accordance with plans and specifications approved by the Department of Transportation (Division of Project Development) and Zoning Department - Signs.

This grant of privilege in the public way shall be subject to the provisions of Section 10-28-015 and all other required provisions of the Municipal Code of Chicago.

The grantee shall pay to the City of Chicago as compensation for the privilege #1113010 herein granted the sum of one hundred seventy-five (\$175.00) per annum in advance.

A 25% penalty will be added for payments received after due date.

The permit holder agrees to hold the City of Chicago harmless for any damage, relocation or replacement costs associated with damage, relocation or removal of private property caused by the City performing work in the public way.

Authority herein given and granted for a period of five (5) years from and after 05/13/2014.

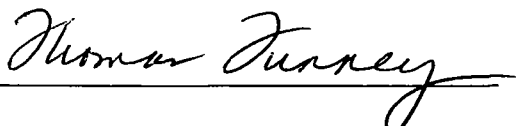
Alderman 
Thomas Tunney 44th Ward

Date

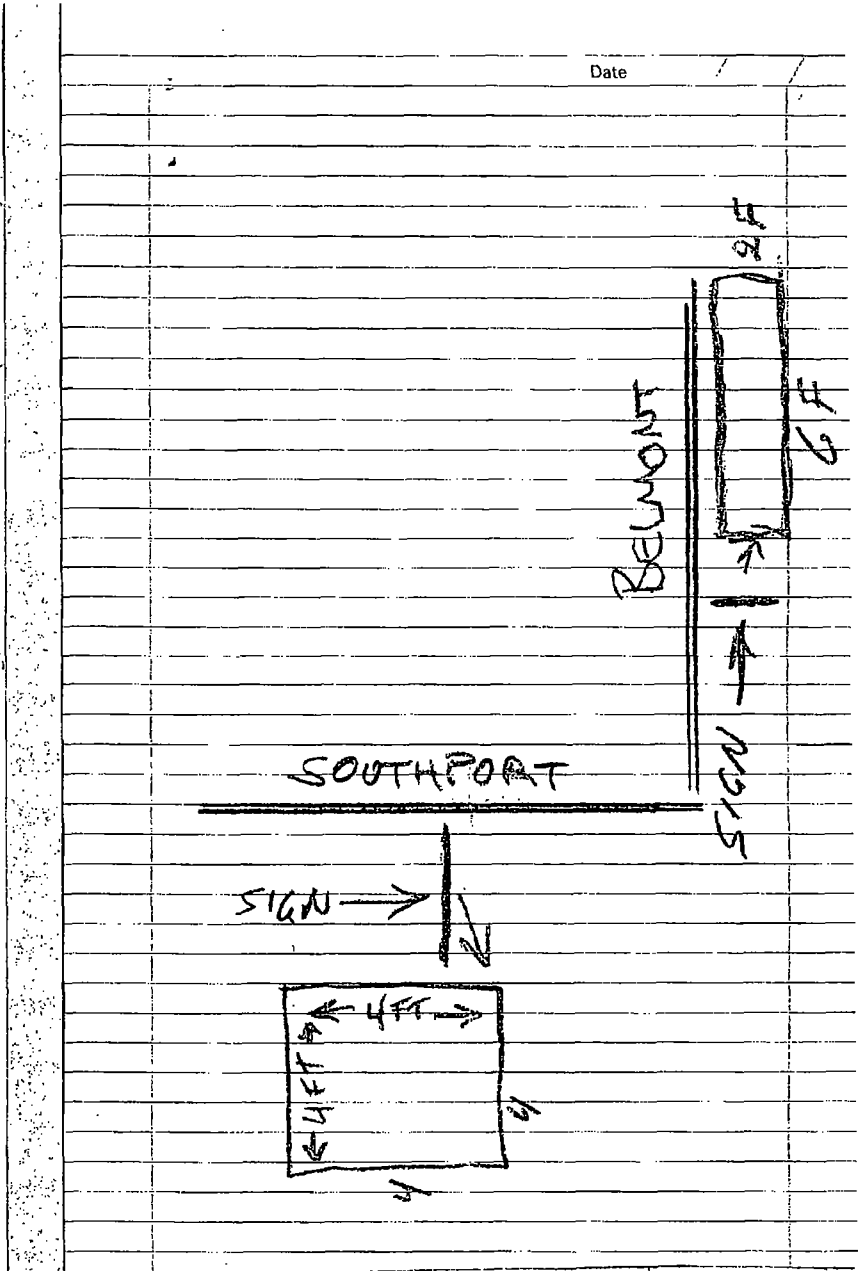



City of Chicago



O2014-4816

Office of the City Clerk

Document Tracking Sheet

| | |
|---------------------------------|---|
| Meeting Date: | 5/28/2014 |
| Sponsor(s): | Tunney (44) |
| Type: | Ordinance |
| Title: | Grant(s) of privilege in public way for Lakeview Ace Hardware, Inc. |
| Committee(s) Assignment: | Committee on Transportation and Public Way |

ORDINANCE
LAKEVIEW ACE HARDWARE, INC.
Acct. No. 63068 - 1
Permit No. 1098735

Be It Ordained by the City Council of the City of Chicago:

SECTION 1. Permission and authority are hereby given and granted to LAKEVIEW ACE HARDWARE, INC., upon the terms and subject to the conditions of this ordinance to maintain and use two (2) sign(s) projecting over the public right-of-way attached to its premises known as 3921 N. Sheridan Rd..

Said sign structure(s) measures as follows; along S. Sheridan Rd:
One (1) at fifteen (15) feet in length, three (3) feet in height and fourteen (14) feet above grade level.
One (1) at six (6) feet in length, four (4) feet in height and ten (10) feet above grade level.

The location of said privilege shall be as shown on prints kept on file with the Department of Business Affairs and Consumer Protection and the Office of the City Clerk.

Said privilege shall be constructed in accordance with plans and specifications approved by the Department of Transportation (Division of Project Development) and Zoning Department - Signs.

This grant of privilege in the public way shall be subject to the provisions of Section 10-28-015 and all other required provisions of the Municipal Code of Chicago.

The grantee shall pay to the City of Chicago as compensation for the privilege #1098735 herein granted the sum of four hundred (\$400.00) per annum in advance.

A 25% penalty will be added for payments received after due date.

The permit holder agrees to hold the City of Chicago harmless for any damage, relocation or replacement costs associated with damage, relocation or removal of private property caused by the City performing work in the public way.

Authority herein given and granted for a period of five (5) years from and after Date of Passage.

Alderman 

Thomas Tunney 44th Ward

APPLICATION TO USE THE PUBLIC RIGHT OF WAY

Sign Drawing #1

LAKEVIEW ACE HARDWARE, INC Acct 63068
3921 N STEPHEN ROAD

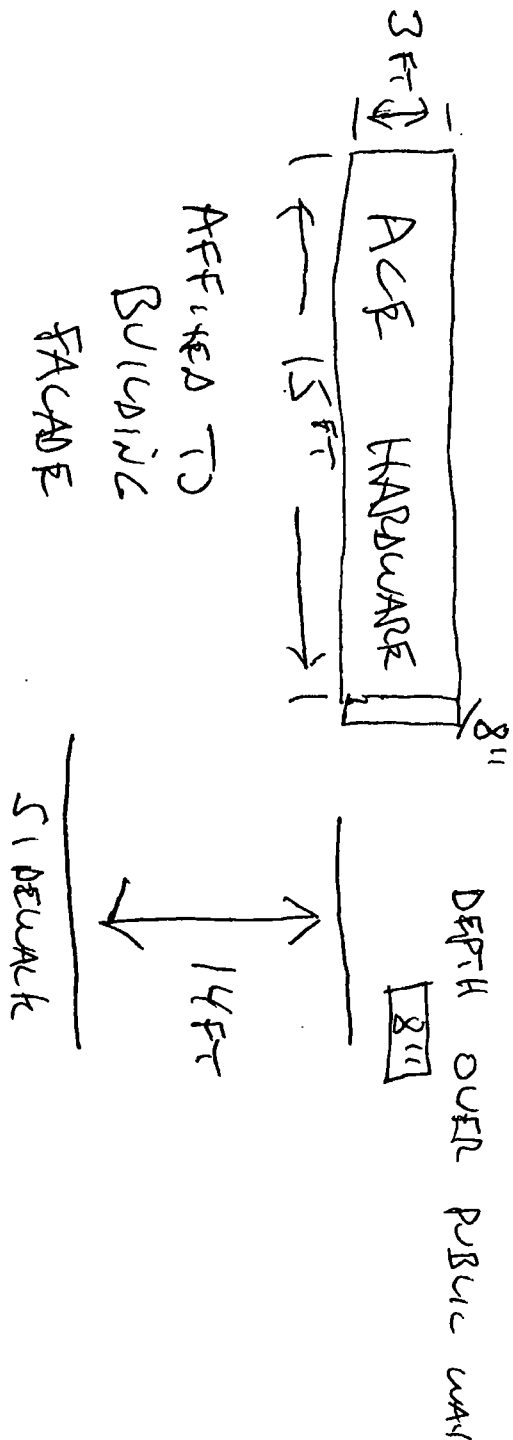



City of Chicago



O2014-4820

Office of the City Clerk

Document Tracking Sheet

| | |
|---------------------------------|---|
| Meeting Date: | 5/28/2014 |
| Sponsor(s): | Tunney (44) |
| Type: | Ordinance |
| Title: | Grant(s) of privilege in public way for O'Malley's Liquor Kitchen |
| Committee(s) Assignment: | Committee on Transportation and Public Way |

ORDINANCE
OMALLEY'S LIQUOR KITCHEN
Acct. No. 8109 - 1
Permit No. 1113116

Be It Ordained by the City Council of the City of Chicago:

SECTION 1. Permission and authority are hereby given and granted to OMALLEY'S LIQUOR KITCHEN, upon the terms and subject to the conditions of this ordinance to maintain and use two (2) sign(s) projecting over the public right-of-way attached to its premises known as 3551 N. Sheffield Ave..

Said sign structure(s) measures as follows; along N. SHEFFIELD:
One (1) at ten (10) feet in length, eight point three three (8.33) feet in height and nine (9) feet above grade level.

Said sign structure(s) measures as follows; along N. SHEFFIELD:
One (1) at eight (8) feet in length, six (6) feet in height and nine (9) feet above grade level.

The location of said privilege shall be as shown on prints kept on file with the Department of Business Affairs and Consumer Protection and the Office of the City Clerk.

Said privilege shall be constructed in accordance with plans and specifications approved by the Department of Transportation (Division of Project Development) and Zoning Department - Signs.

This grant of privilege in the public way shall be subject to the provisions of Section 10-28-015 and all other required provisions of the Municipal Code of Chicago.

The grantee shall pay to the City of Chicago as compensation for the privilege #1113116 herein granted the sum of six hundred (\$600.00) per annum in advance.

A 25% penalty will be added for payments received after due date.

The permit holder agrees to hold the City of Chicago harmless for any damage, relocation or replacement costs associated with damage, relocation or removal of private property caused by the City performing work in the public way.

Authority herein given and granted for a period of five (5) years from and after 07/09/2013.

Alderman 
Thomas Tunney 44th Ward

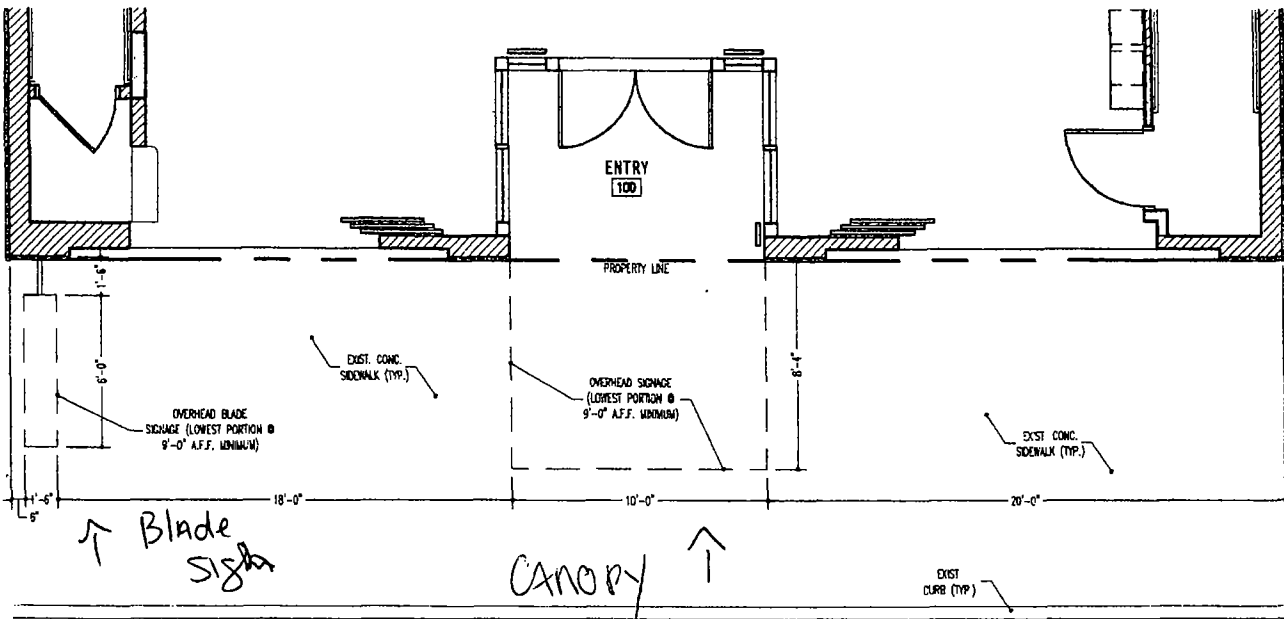

N. SHEFFIELD AVENUE



ASK501 EXISTING SITE PLAN

SCALE:

3/16"=1'-0"

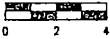

| | |
|---|-----------------------|
| PROJECT NUMBER | ASK501 |
| DATE | 12-15-10 |
| DESIGNED BY | ARCHITECTURE + DESIGN |
| DRAWN BY | ARCHITECTURE + DESIGN |
| CHECKED BY | ARCHITECTURE + DESIGN |
| DATE | 12-15-10 |
| berk / nestor + ARCHITECTURE + DESIGN 415 WENTZELL AVE. SUITE 1, BOSTON, MA 02118 TEL: 617-734-1882 FAX: 617-734-1877 | |
| RESTAURANT & BAR RENOVATIONS 3551 N. SHEFFIELD AVE. CHICAGO, ILLINOIS 60647 | |
| ASK5 | |



City of Chicago



O2014-4821

Office of the City Clerk

Document Tracking Sheet

| | |
|---------------------------------|---|
| Meeting Date: | 5/28/2014 |
| Sponsor(s): | Tunney (44) |
| Type: | Ordinance |
| Title: | Grant(s) of privilege in public way for Secrets |
| Committee(s) Assignment: | Committee on Transportation and Public Way |

ORDINANCE
SECRETS
Acct. No. 43951 - 1
Permit No. 1112965

Be It Ordained by the City Council of the City of Chicago:

SECTION 1. Permission and authority are hereby given and granted to SECRETS, upon the terms and subject to the conditions of this ordinance to maintain and use one (1) sign(s) projecting over the public right-of-way attached to its premises known as 3229 N. Clark St..

Said sign structure(s) measures as follows; along N CLARK ST:
One (1) at twenty-one (21) feet in length, three (3) feet in height and twelve (12) feet above grade level.

The location of said privilege shall be as shown on prints kept on file with the Department of Business Affairs and Consumer Protection and the Office of the City Clerk.

Said privilege shall be constructed in accordance with plans and specifications approved by the Department of Transportation (Division of Project Development) and Zoning Department - Signs.

This grant of privilege in the public way shall be subject to the provisions of Section 10-28-015 and all other required provisions of the Municipal Code of Chicago.

The grantee shall pay to the City of Chicago as compensation for the privilege #1112965 herein granted the sum of three hundred (\$300.00) per annum in advance.

A 25% penalty will be added for payments received after due date.

The permit holder agrees to hold the City of Chicago harmless for any damage, relocation or replacement costs associated with damage, relocation or removal of private property caused by the City performing work in the public way.

Authority herein given and granted for a period of five (5) years from and after 05/13/2014.

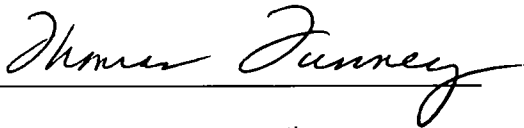
Alderman 
Thomas Tunney 44th Ward

11 Inches Depth →

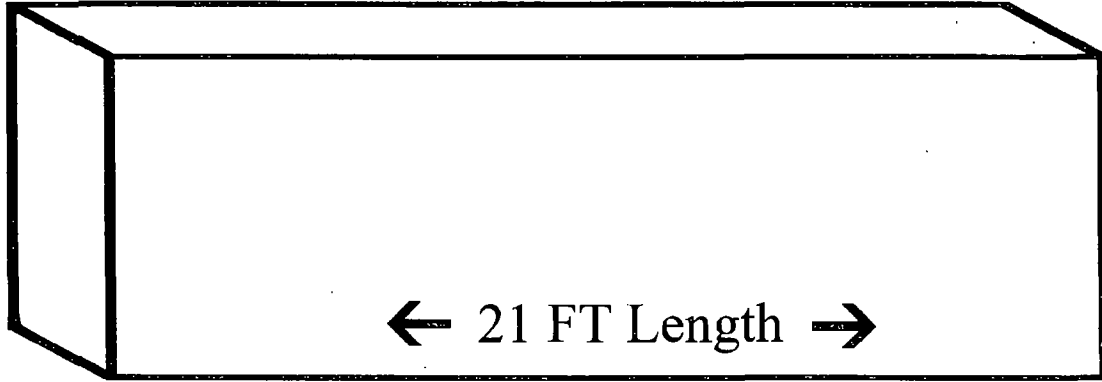

← 21 FT Length →

↑
3 FT
Height
↓

↑
12 FT
Above Grade
↓



City of Chicago



O2014-4823

Office of the City Clerk

Document Tracking Sheet

| | |
|---------------------------------|---|
| Meeting Date: | 5/28/2014 |
| Sponsor(s): | Tunney (44) |
| Type: | Ordinance |
| Title: | Grant(s) of privilege in public way for Standard Bank & Trust Company |
| Committee(s) Assignment: | Committee on Transportation and Public Way |

ORDINANCE
STANDARD BANK & TRUST COMPANY
Acct. No. 274791 - 7
Permit No. 1113071

Be It Ordained by the City Council of the City of Chicago:

SECTION 1. Permission and authority are hereby given and granted to STANDARD BANK & TRUST COMPANY, upon the terms and subject to the conditions of this ordinance to maintain and use two (2) sign(s) projecting over the public right-of-way attached to its premises known as 3920 N. Sheridan Rd..

Said sign structure(s) measures as follows; along N. SHERIDAN RD.:
Two (2) at thirty (30) feet in length, two point zero eight (2.08) feet in height and twelve (12) feet above grade level.

The location of said privilege shall be as shown on prints kept on file with the Department of Business Affairs and Consumer Protection and the Office of the City Clerk.

Said privilege shall be constructed in accordance with plans and specifications approved by the Department of Transportation (Division of Project Development) and Zoning Department - Signs.

This grant of privilege in the public way shall be subject to the provisions of Section 10-28-015 and all other required provisions of the Municipal Code of Chicago.

The grantee shall pay to the City of Chicago as compensation for the privilege #1113071 herein granted the sum of six hundred (\$600.00) per annum in advance.

A 25% penalty will be added for payments received after due date.

The permit holder agrees to hold the City of Chicago harmless for any damage, relocation or replacement costs associated with damage, relocation or removal of private property caused by the City performing work in the public way.

Authority herein given and granted for a period of five (5) years from and after 05/13/2014.

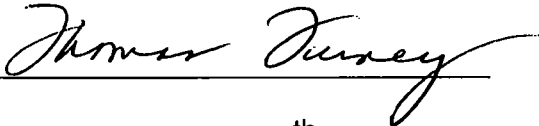
Alderman 
Thomas Tunney 44th Ward





City of Chicago



O2014-4785

Office of the City Clerk

Document Tracking Sheet

| | |
|---------------------------------|--|
| Meeting Date: | 5/28/2014 |
| Sponsor(s): | Arena (45) |
| Type: | Ordinance |
| Title: | Grant(s) of privilege in public way for Accelerated Rehabilitation Centers |
| Committee(s) Assignment: | Committee on Transportation and Public Way |

ORDINANCE
accelerated rehabilitation centers
Acct. No. 69020 - 1
Permit No. 1112957

Be It Ordained by the City Council of the City of Chicago:

SECTION 1. Permission and authority are hereby given and granted to accelerated rehabilitation centers, upon the terms and subject to the conditions of this ordinance to maintain and use one (1) sign(s) projecting over the public right-of-way attached to its premises known as 4008 N. Cicero Ave..

Said sign structure(s) measures as follows; along N. CICERO AVE:
One (1) at twenty-six point five (26.5) feet in length, two (2) feet in height and eleven (11) feet above grade level.

The location of said privilege shall be as shown on prints kept on file with the Department of Business Affairs and Consumer Protection and the Office of the City Clerk.

Said privilege shall be constructed in accordance with plans and specifications approved by the Department of Transportation (Division of Project Development) and Zoning Department - Signs.

This grant of privilege in the public way shall be subject to the provisions of Section 10-28-015 and all other required provisions of the Municipal Code of Chicago.

The grantee shall pay to the City of Chicago as compensation for the privilege #1112957 herein granted the sum of three hundred (\$300.00) per annum in advance.

A 25% penalty will be added for payments received after due date.

The permit holder agrees to hold the City of Chicago harmless for any damage, relocation or replacement costs associated with damage, relocation or removal of private property caused by the City performing work in the public way.

Authority herein given and granted for a period of five (5) years from and after 01/13/2014.

Alderman

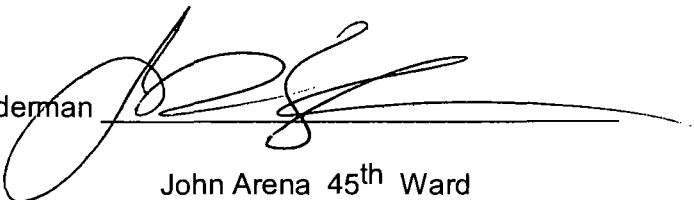
A handwritten signature in black ink, appearing to read 'John Arena', written over a horizontal line. The signature is stylized and cursive.

John Arena 45th Ward

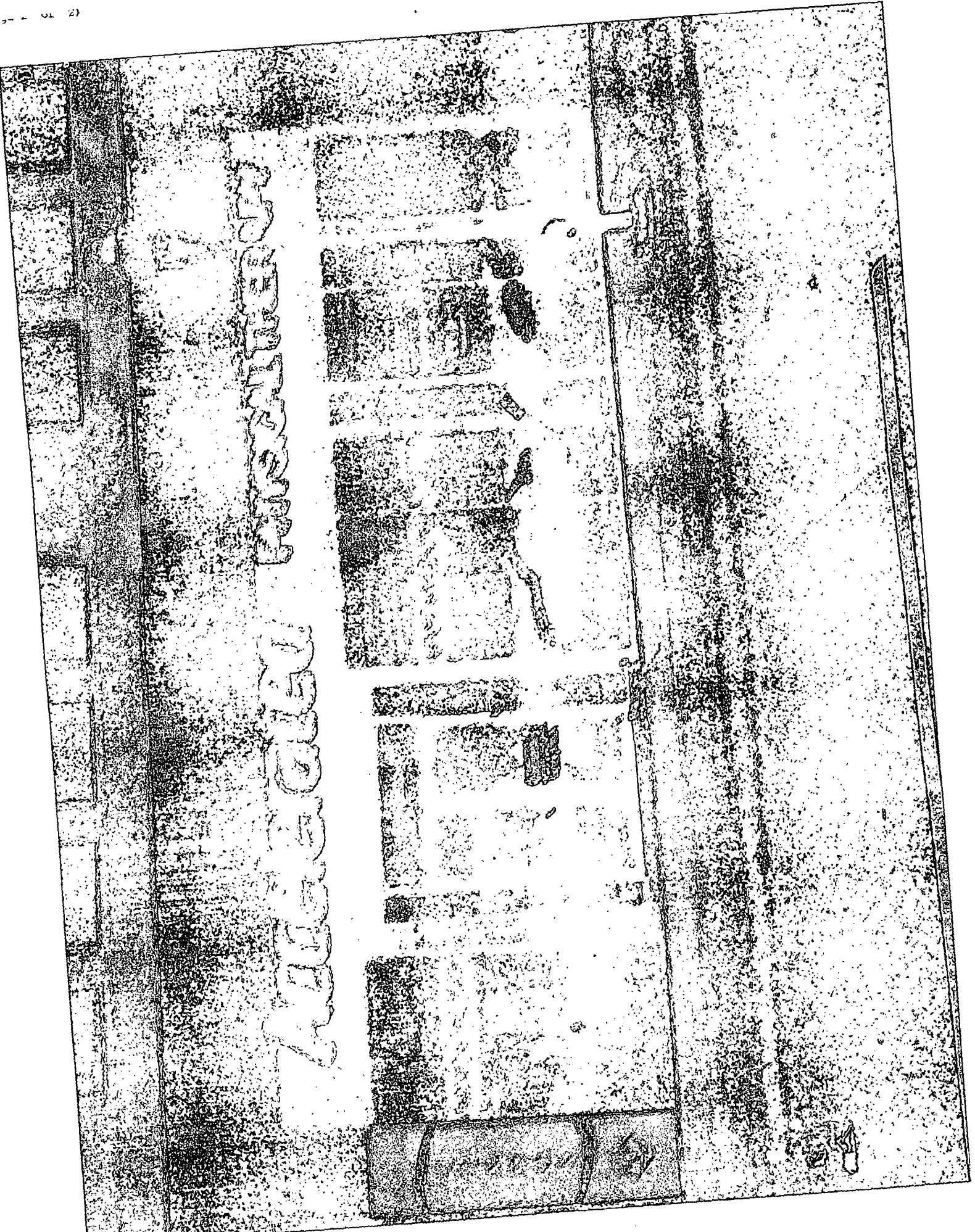



Department of Business Affairs and Consumer Protection
Small Business Center - Public Way Use Unit
City Hall - 121 N. LaSalle Street, Room 800 • Chicago, IL 60602
(312)-74-GOBIZ (312-744-6249) • (312) 744-1944 (TTY)
<http://www.cityofchicago.org/bacp>

05/28/2014

Alderman **John Arena**
Ward # **45**
City of Chicago
City Hall, Room **305**
121 North LaSalle Street
Chicago, Illinois 60602

Re: An ordinance to use and maintain a portion of the public right-of-way for **one (1) sign(s)** for **accelerated rehabilitation centers**, adjacent to the premises known as **4008 N. Cicero Ave.**.

Dear Alderman **John Arena**:

The applicant referenced above has requested the use of the public right-of-way for a **sign(s)**. An ordinance has been prepared by the Department of Business Affairs and Consumer Protection – Small Business Center - Public Way Use Unit for presentation to the City Council. Because this request was made for properties located in your ward, as approved by you as per the attached, I respectfully request that you introduce the attached ordinance at the next City Council meeting.

If you have any questions regarding this ordinance, please contact Anthony Bertuca at (312) 744-5506.

Department of Business Affairs and Consumer Protection



City of Chicago



O2014-4787

Office of the City Clerk

Document Tracking Sheet

| | |
|---------------------------------|--|
| Meeting Date: | 5/28/2014 |
| Sponsor(s): | Arena (45) |
| Type: | Ordinance |
| Title: | Grant(s) of privilege in public way for Central Milwaukee Currency Exchange, Inc. |
| Committee(s) Assignment: | Committee on Transportation and Public Way |

ORDINANCE
CENTRAL MILWAUKEE CURRENCY EXCHANGE, INC.
Acct. No. 346392 - 1
Permit No. 1113149

Be It Ordained by the City Council of the City of Chicago:

SECTION 1. Permission and authority are hereby given and granted to CENTRAL MILWAUKEE CURRENCY EXCHANGE, INC., upon the terms and subject to the conditions of this ordinance to maintain and use one (1) sign(s) projecting over the public right-of-way attached to its premises known as 5306 N. Milwaukee Ave..

Said sign structure(s) measures as follows; along N. Milwaukee Avenue:
One (1) at ten (10) feet in length, ten (10) feet in height and ten (10) feet above grade level.

The location of said privilege shall be as shown on prints kept on file with the Department of Business Affairs and Consumer Protection and the Office of the City Clerk.

Said privilege shall be constructed in accordance with plans and specifications approved by the Department of Transportation (Division of Project Development) and Zoning Department - Signs.

This grant of privilege in the public way shall be subject to the provisions of Section 10-28-015 and all other required provisions of the Municipal Code of Chicago.

The grantee shall pay to the City of Chicago as compensation for the privilege #1113149 herein granted the sum of three hundred (\$300.00) per annum in advance.

A 25% penalty will be added for payments received after due date.

The permit holder agrees to hold the City of Chicago harmless for any damage, relocation or replacement costs associated with damage, relocation or removal of private property caused by the City performing work in the public way.

Authority herein given and granted for a period of five (5) years from and after 01/13/2014.

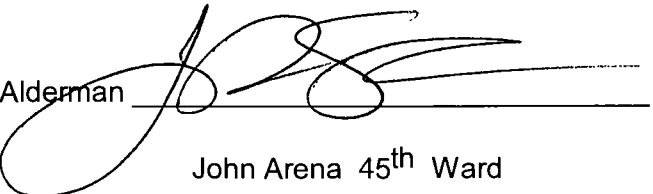
Alderman 
John Arena 45th Ward

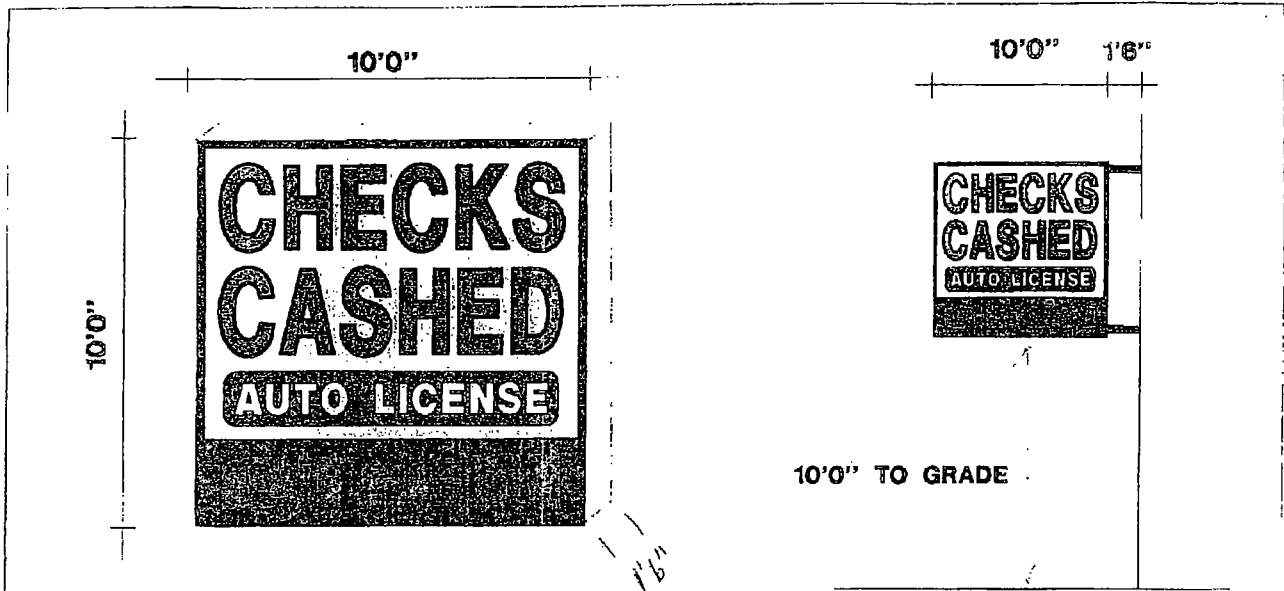

10'0" x 10'0" PROJECTING SIGN

| | |
|--|----------------|
| BEST NEON SIGN CO. | |
| SCALE NO SCALE | PK. NO. PUBVIO |
| CUSTOMER <i>Central & Milwaukee Co. E.</i> | |
| JOB ADDRESS 5306 N. MILWAUKEE | |
| CITY CHICAGO | STATE IL. |
| ARTIST | DATE |
| SALES APPROVED | DATE |
| CUSTOMER APPROVAL: | |

By signing the approval box on this sketch, I understand that I am accepting all aspects of this drawing. This includes artwork, specifications, dimensions, spelling and any other representations herein. I also understand that color reproductions on this sketch are approximate, and may not match manufactured product exactly.



05/28/2014

Alderman **John Arena**
Ward # **45**
City of Chicago
City Hall, Room **305**
121 North LaSalle Street
Chicago, Illinois 60602

Re: An ordinance to use and maintain a portion of the public right-of-way for **one (1) sign(s)** for
CENTRAL MILWAUKEE CURRENCY EXCHANGE, INC., adjacent to the premises known as
5306 N. Milwaukee Ave..

Dear Alderman **John Arena**:

The applicant referenced above has requested the use of the public right-of-way for a **sign(s)**. An ordinance has been prepared by the Department of Business Affairs and Consumer Protection – Small Business Center - Public Way Use Unit for presentation to the City Council. Because this request was made for properties located in your ward, as approved by you as per the attached, I respectfully request that you introduce the attached ordinance at the next City Council meeting.

If you have any questions regarding this ordinance, please contact Anthony Bertuca at (312) 744-5506.

Department of Business Affairs and Consumer Protection



City of Chicago



O2014-4790

Office of the City Clerk

Document Tracking Sheet

| | |
|---------------------------------|--|
| Meeting Date: | 5/28/2014 |
| Sponsor(s): | Arena (45) |
| Type: | Ordinance |
| Title: | Grant(s) of privilege in public way for Foremost Liquor Center |
| Committee(s) Assignment: | Committee on Transportation and Public Way |

ORDINANCE
FOREMOST LIQUOR CENTER
Acct. No. 31031 - 1
Permit No. 1113048

Be It Ordained by the City Council of the City of Chicago:

SECTION 1. Permission and authority are hereby given and granted to FOREMOST LIQUOR CENTER, upon the terms and subject to the conditions of this ordinance to maintain and use two (2) sign(s) projecting over the public right-of-way attached to its premises known as 5301 N. Milwaukee Ave..

Said sign structure(s) measures as follows; along N MILWAUKEE AVE:

One (1) at twelve point five eight (12.58) feet in length, six point five eight (6.58) feet in height and thirteen point five eight (13.58) feet above grade level.

Said sign structure(s) measures as follows; along MILWAUKEE & CENTRAL:

One (1) at ten (10) feet in length, seven point five eight (7.58) feet in height and eleven point two five (11.25) feet above grade level.

The location of said privilege shall be as shown on prints kept on file with the Department of Business Affairs and Consumer Protection and the Office of the City Clerk.

Said privilege shall be constructed in accordance with plans and specifications approved by the Department of Transportation (Division of Project Development) and Zoning Department - Signs.

This grant of privilege in the public way shall be subject to the provisions of Section 10-28-015 and all other required provisions of the Municipal Code of Chicago.

The grantee shall pay to the City of Chicago as compensation for the privilege #1113048 herein granted the sum of six hundred (\$600.00) per annum in advance.

A 25% penalty will be added for payments received after due date.

The permit holder agrees to hold the City of Chicago harmless for any damage, relocation or replacement costs associated with damage, relocation or removal of private property caused by the City performing work in the public way.

Authority herein given and granted for a period of five (5) years from and after 04/22/2014.

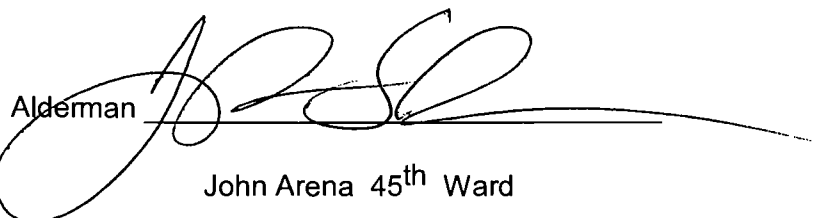
Alderman 
John Arena 45th Ward

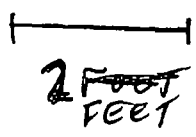
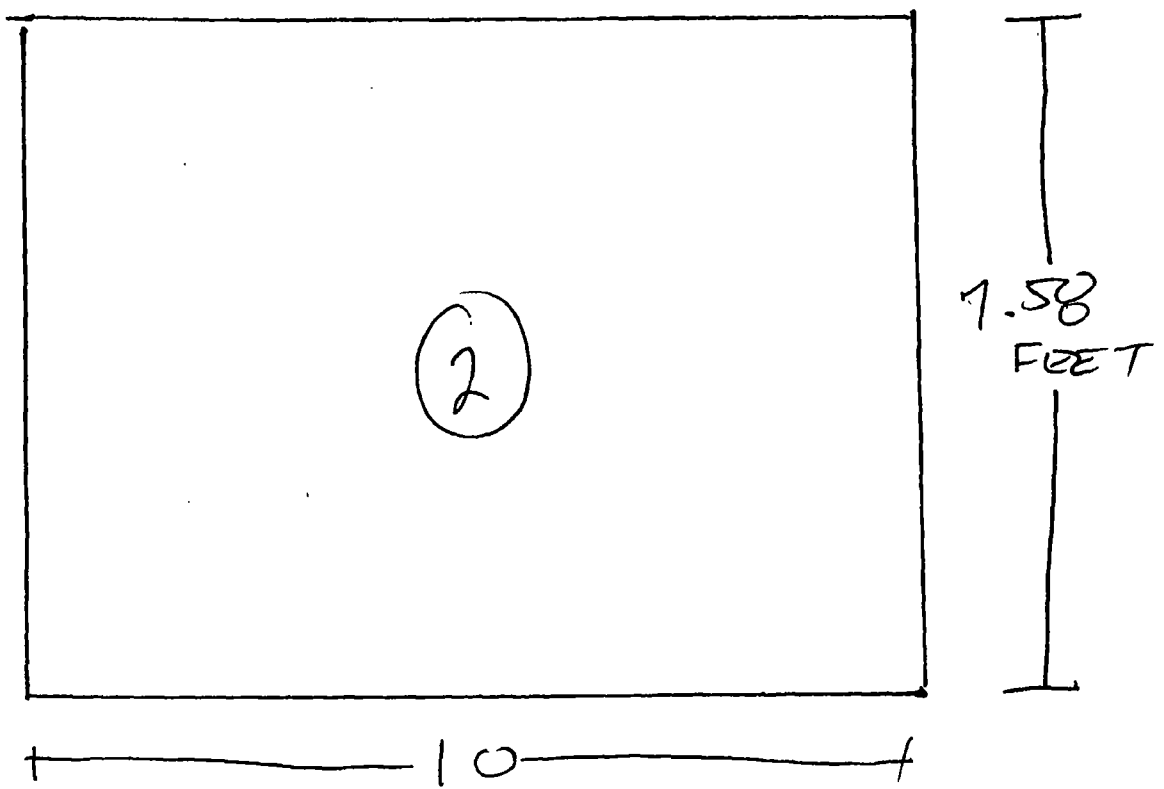
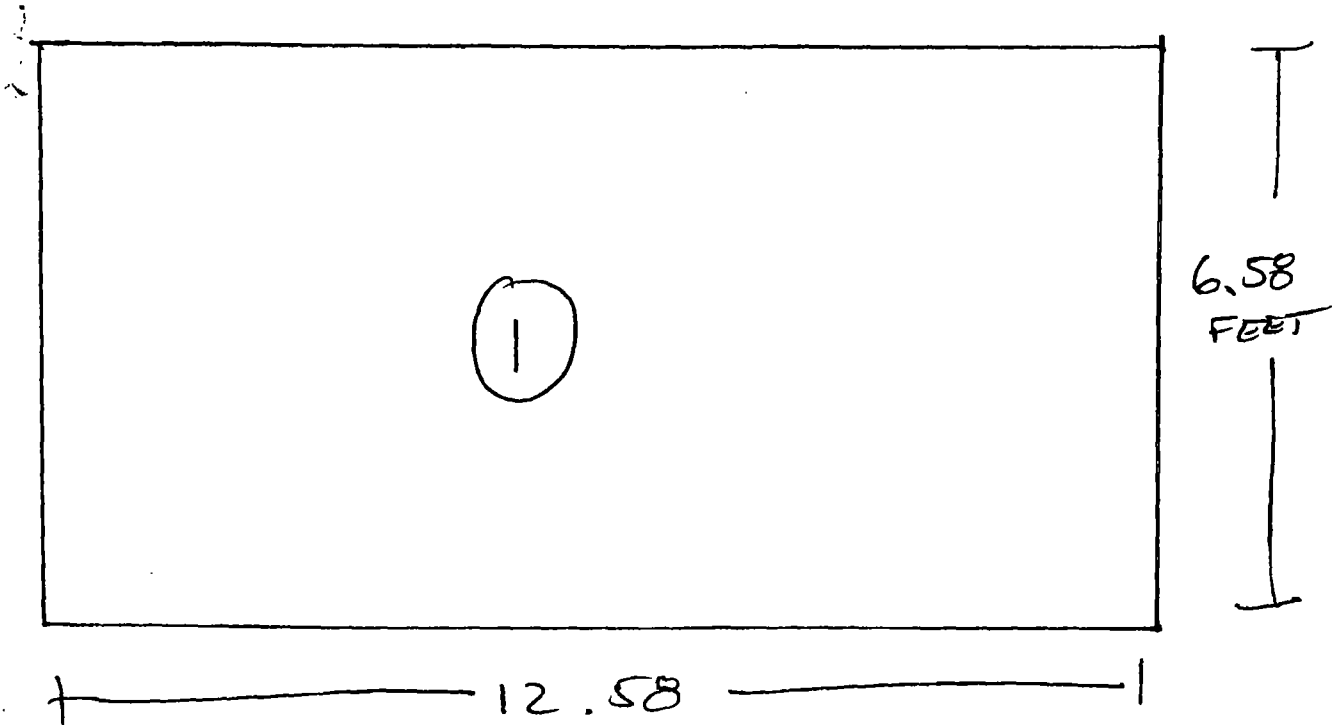



Department of Business Affairs and Consumer Protection
Small Business Center - Public Way Use Unit
City Hall - 121 N. LaSalle Street, Room 800 • Chicago, IL 60602
(312)-74-GOBIZ (312-744-6249) • (312) 744-1944 (TTY)
<http://www.cityofchicago.org/bacp>

05/28/2014

Alderman **John Arena**
Ward # **45**
City of Chicago
City Hall, Room **305**
121 North LaSalle Street
Chicago, Illinois 60602

Re: An ordinance to use and maintain a portion of the public right-of-way for **two (2) sign(s)** for
FOREMOST LIQUOR CENTER, adjacent to the premises known as **5301 N. Milwaukee Ave.**.

Dear Alderman **John Arena**:

The applicant referenced above has requested the use of the public right-of-way for a **sign(s)**. An ordinance has been prepared by the Department of Business Affairs and Consumer Protection – Small Business Center - Public Way Use Unit for presentation to the City Council. Because this request was made for properties located in your ward, as approved by you as per the attached, I respectfully request that you introduce the attached ordinance at the next City Council meeting.

If you have any questions regarding this ordinance, please contact Anthony Bertuca at (312) 744-5506.

Department of Business Affairs and Consumer Protection



City of Chicago



O2014-4792

Office of the City Clerk

Document Tracking Sheet

| | |
|---------------------------------|---|
| Meeting Date: | 5/28/2014 |
| Sponsor(s): | Arena (45) |
| Type: | Ordinance |
| Title: | Grant(s) of privilege in public way for Irving-Cicero Currency Exchange, Inc. |
| Committee(s) Assignment: | Committee on Transportation and Public Way |

ORDINANCE
IRVING-CICERO CURRENCY EXCHANGE INC.
Acct. No. 47636 - 1
Permit No. 1112941

Be It Ordained by the City Council of the City of Chicago:

SECTION 1. Permission and authority are hereby given and granted to IRVING-CICERO CURRENCY EXCHANGE INC., upon the terms and subject to the conditions of this ordinance to maintain and use two (2) sign(s) projecting over the public right-of-way attached to its premises known as 4814 W. Irving Park Rd..

Said sign structure(s) measures as follows; along W. Irving Park Road:
One (1) at eight (8) feet in length, ten (10) feet in height and nine point six (9.6) feet above grade level.

Said sign structure(s) measures as follows; along N. Milwaukee:
One (1) at eight (8) feet in length, ten (10) feet in height and nine point six (9.6) feet above grade level.

The location of said privilege shall be as shown on prints kept on file with the Department of Business Affairs and Consumer Protection and the Office of the City Clerk.

Said privilege shall be constructed in accordance with plans and specifications approved by the Department of Transportation (Division of Project Development) and Zoning Department - Signs.

This grant of privilege in the public way shall be subject to the provisions of Section 10-28-015 and all other required provisions of the Municipal Code of Chicago.

The grantee shall pay to the City of Chicago as compensation for the privilege #1112941 herein granted the sum of six hundred (\$600.00) per annum in advance.

A 25% penalty will be added for payments received after due date.

The permit holder agrees to hold the City of Chicago harmless for any damage, relocation or replacement costs associated with damage, relocation or removal of private property caused by the City performing work in the public way.

Authority herein given and granted for a period of five (5) years from and after 11/19/2013.

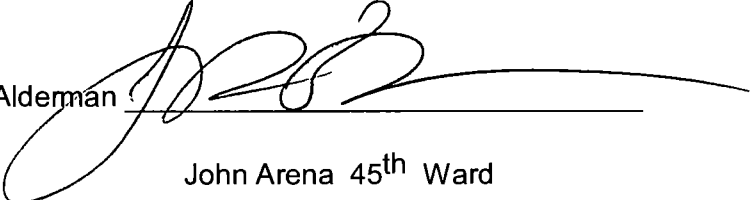
Alderman 
John Arena 45th Ward

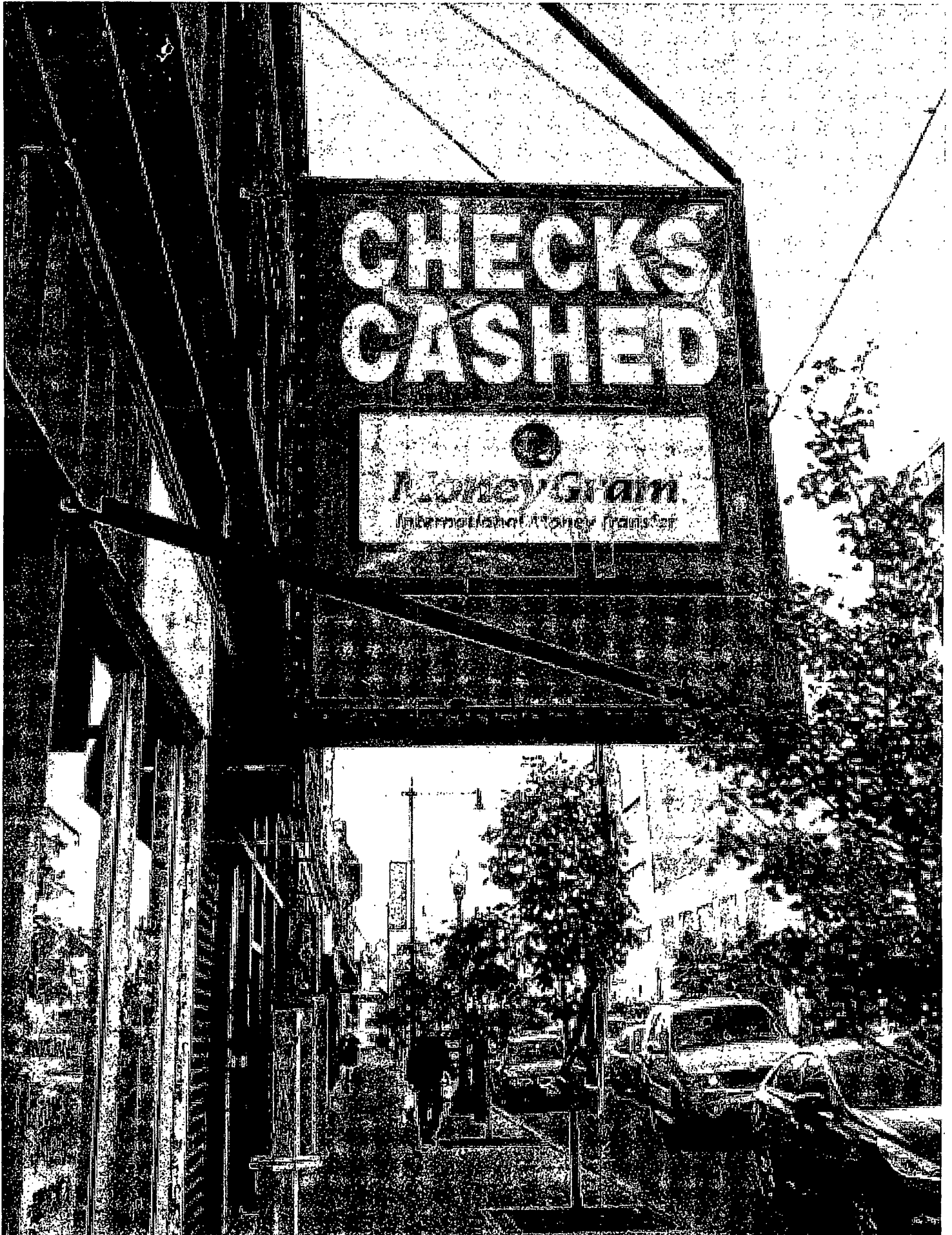



Department of Business Affairs and Consumer Protection
Small Business Center - Public Way Use Unit
City Hall - 121 N. LaSalle Street, Room 800 • Chicago, IL 60602
(312)-74-GOBIZ (312-744-6249) • (312) 744-1944 (TTY)
<http://www.cityofchicago.org/bacp>

05/28/2014

Alderman **John Arena**
Ward # **45**
City of Chicago
City Hall, Room **305**
121 North LaSalle Street
Chicago, Illinois 60602

Re: An ordinance to use and maintain a portion of the public right-of-way for **two (2) sign(s)** for **IRVING-CICERO CURRENCY EXCHANGE INC.**, adjacent to the premises known as **4814 W. Irving Park Rd.**.

Dear Alderman **John Arena**:

The applicant referenced above has requested the use of the public right-of-way for a **sign(s)**. An ordinance has been prepared by the Department of Business Affairs and Consumer Protection – Small Business Center - Public Way Use Unit for presentation to the City Council. Because this request was made for properties located in your ward, as approved by you as per the attached, I respectfully request that you introduce the attached ordinance at the next City Council meeting.

If you have any questions regarding this ordinance, please contact Anthony Bertuca at (312) 744-5506.

Department of Business Affairs and Consumer Protection



City of Chicago



O2014-4794

Office of the City Clerk

Document Tracking Sheet

| | |
|---------------------------------|---|
| Meeting Date: | 5/28/2014 |
| Sponsor(s): | Arena (45) |
| Type: | Ordinance |
| Title: | Grant(s) of privilege in public way for Kingston Reflexology LLC |
| Committee(s) Assignment: | Committee on Transportation and Public Way |

ORDINANCE
KINGSTON REFLEXOLOGY LLC
Acct. No. 385617 - 1
Permit No. 1111945

Be It Ordained by the City Council of the City of Chicago:

SECTION 1. Permission and authority are hereby given and granted to KINGSTON REFLEXOLOGY LLC, upon the terms and subject to the conditions of this ordinance to maintain and use one (1) sign(s) projecting over the public right-of-way attached to its premises known as 4034 N. Milwaukee Ave..

Said sign structure(s) measures as follows; along N. Milwaukee Avenue:
One (1) at thirteen (13) feet in length, two (2) feet in height and eleven (11) feet above grade level.

The location of said privilege shall be as shown on prints kept on file with the Department of Business Affairs and Consumer Protection and the Office of the City Clerk.

Said privilege shall be constructed in accordance with plans and specifications approved by the Department of Transportation (Division of Project Development) and Zoning Department - Signs.

This grant of privilege in the public way shall be subject to the provisions of Section 10-28-015 and all other required provisions of the Municipal Code of Chicago.

The grantee shall pay to the City of Chicago as compensation for the privilege #1111945 herein granted the sum of three hundred (\$300.00) per annum in advance.

A 25% penalty will be added for payments received after due date.

The permit holder agrees to hold the City of Chicago harmless for any damage, relocation or replacement costs associated with damage, relocation or removal of private property caused by the City performing work in the public way.

Authority herein given and granted for a period of five (5) years from and after Date of Passage.

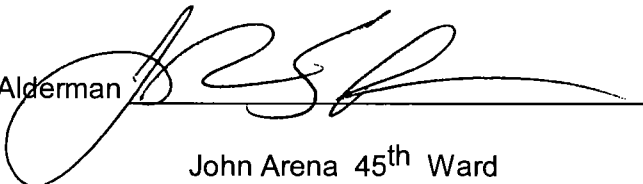
Alderman 
John Arena 45th Ward



Athena Design Group

1882 S. Normal Avenue, Chicago, IL 60616 | Tel: 312-733-2828 | Fax: 312-733-2822 | E-mail: adg@3228.com

14'

2'



8"



8" thick illuminated aluminum box screwed into brick wall using 1.5" long masonry screws. Screws are 12" apart from each other.

Sign permit, bond, and special insurance required by the city are extra.

Client: Li Hing Inc.

Date: 3/7/2014

All sign designs and concepts shown here are confidential and are the property of ADG. They are not to be distributed, exhibited, copied, or otherwise used without our written permission. Computer generated colors are not a true match to any PMS, VINYL, or PAINT.

Site Address: 5754 W. Belmont Ave., Chicago, IL 60634

Sign Type: light box



05/28/2014

Alderman **John Arena**
Ward # **45**
City of Chicago
City Hall, Room **305**
121 North LaSalle Street
Chicago, Illinois 60602

Re: An ordinance to use and maintain a portion of the public right-of-way for **one (1) sign(s)** for **KINGSTON REFLEXOLOGY LLC**, adjacent to the premises known as **4034 N. Milwaukee Ave.**.

Dear Alderman **John Arena**:

The applicant referenced above has requested the use of the public right-of-way for a **sign(s)**. An ordinance has been prepared by the Department of Business Affairs and Consumer Protection – Small Business Center - Public Way Use Unit for presentation to the City Council. Because this request was made for properties located in your ward, as approved by you as per the attached, I respectfully request that you introduce the attached ordinance at the next City Council meeting.

If you have any questions regarding this ordinance, please contact Anthony Bertuca at (312) 744-5506.

Department of Business Affairs and Consumer Protection



City of Chicago



O2014-4798

Office of the City Clerk

Document Tracking Sheet

| | |
|---------------------------------|---|
| Meeting Date: | 5/28/2014 |
| Sponsor(s): | Arena (45) |
| Type: | Ordinance |
| Title: | Grant(s) of privilege in public way for Unique Travel |
| Committee(s) Assignment: | Committee on Transportation and Public Way |

ORDINANCE
UNIQUE TRAVEL
Acct. No. 27812 - 2
Permit No. 1113028

Be It Ordained by the City Council of the City of Chicago:

SECTION 1. Permission and authority are hereby given and granted to UNIQUE TRAVEL, upon the terms and subject to the conditions of this ordinance to maintain and use one (1) sign(s) projecting over the public right-of-way attached to its premises known as 5479 N. Milwaukee Ave..

Said sign structure(s) measures as follows; along N. Milwaukee Avenue:
One (1) at eight (8) feet in length, eight (8) feet in height and fourteen (14) feet above grade level.

The location of said privilege shall be as shown on prints kept on file with the Department of Business Affairs and Consumer Protection and the Office of the City Clerk.

Said privilege shall be constructed in accordance with plans and specifications approved by the Department of Transportation (Division of Project Development) and Zoning Department - Signs.

This grant of privilege in the public way shall be subject to the provisions of Section 10-28-015 and all other required provisions of the Municipal Code of Chicago.

The grantee shall pay to the City of Chicago as compensation for the privilege #1113028 herein granted the sum of three hundred (\$300.00) per annum in advance.

A 25% penalty will be added for payments received after due date.

The permit holder agrees to hold the City of Chicago harmless for any damage, relocation or replacement costs associated with damage, relocation or removal of private property caused by the City performing work in the public way.

Authority herein given and granted for a period of five (5) years from and after 04/22/2014.

Alderman

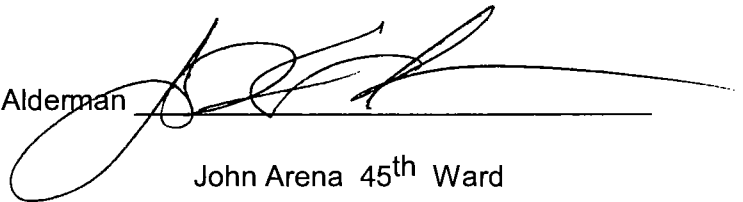
A handwritten signature in black ink, appearing to read 'John Arena', is written over a horizontal line. The signature is stylized and extends to the right of the line.

John Arena 45th Ward

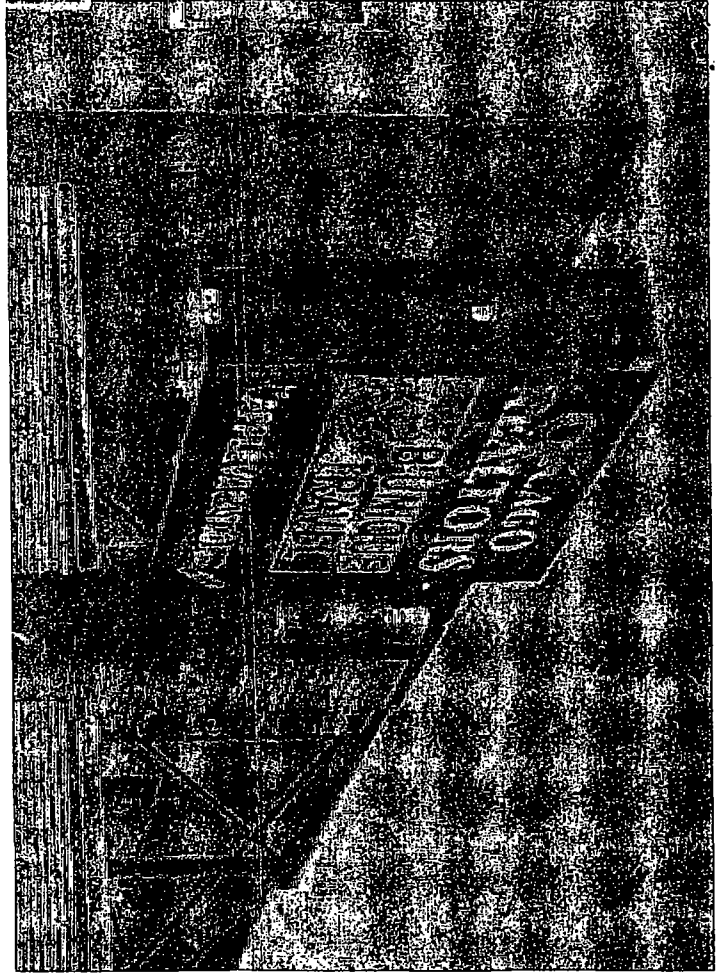



Department of Business Affairs and Consumer Protection
Small Business Center - Public Way Use Unit
City Hall - 121 N. LaSalle Street, Room 800 • Chicago, IL 60602
(312)-74-GOBIZ (312-744-6249) • (312) 744-1944 (TTY)
<http://www.cityofchicago.org/bacp>

05/28/2014

Alderman John Arena
Ward # 45
City of Chicago
City Hall, Room 305
121 North LaSalle Street
Chicago, Illinois 60602

Re: An ordinance to use and maintain a portion of the public right-of-way for **one (1) sign(s)** for **UNIQUE TRAVEL**, adjacent to the premises known as **5479 N. Milwaukee Ave.**

Dear Alderman **John Arena**:

The applicant referenced above has requested the use of the public right-of-way for a **sign(s)**. An ordinance has been prepared by the Department of Business Affairs and Consumer Protection – Small Business Center - Public Way Use Unit for presentation to the City Council. Because this request was made for properties located in your ward, as approved by you as per the attached, I respectfully request that you introduce the attached ordinance at the next City Council meeting.

If you have any questions regarding this ordinance, please contact Anthony Bertuca at (312) 744-5506.

Department of Business Affairs and Consumer Protection



City of Chicago



O2014-4800

Office of the City Clerk

Document Tracking Sheet

| | |
|---------------------------------|--|
| Meeting Date: | 5/28/2014 |
| Sponsor(s): | Arena (45) |
| Type: | Ordinance |
| Title: | Grant(s) of privilege in public way for Valbona's Beauty Salon |
| Committee(s) Assignment: | Committee on Transportation and Public Way |

ORDINANCE
VALBONA'S BEAUTY SALON
Acct. No. 282903 - 2
Permit No. 1113037

Be It Ordained by the City Council of the City of Chicago:

SECTION 1. Permission and authority are hereby given and granted to VALBONA'S BEAUTY SALON, upon the terms and subject to the conditions of this ordinance to maintain and use one (1) sign(s) projecting over the public right-of-way attached to its premises known as 4939 W. Foster Ave..

Said sign structure(s) measures as follows; along 4939 W. FOSTER:
One (1) at eight (8) feet in length, four (4) feet in height and eleven (11) feet above grade level.

The location of said privilege shall be as shown on prints kept on file with the Department of Business Affairs and Consumer Protection and the Office of the City Clerk.

Said privilege shall be constructed in accordance with plans and specifications approved by the Department of Transportation (Division of Project Development) and Zoning Department - Signs.

This grant of privilege in the public way shall be subject to the provisions of Section 10-28-015 and all other required provisions of the Municipal Code of Chicago.

The grantee shall pay to the City of Chicago as compensation for the privilege #1113037 herein granted the sum of three hundred (\$300.00) per annum in advance.

A 25% penalty will be added for payments received after due date.

The permit holder agrees to hold the City of Chicago harmless for any damage, relocation or replacement costs associated with damage, relocation or removal of private property caused by the City performing work in the public way.

Authority herein given and granted for a period of five (5) years from and after 05/13/2014.

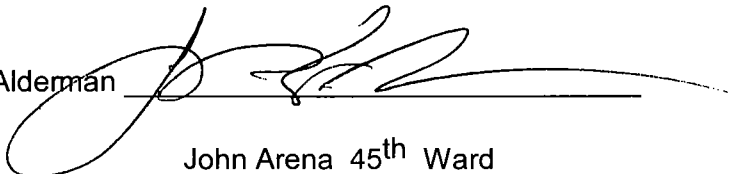
Alderman 
John Arena 45th Ward

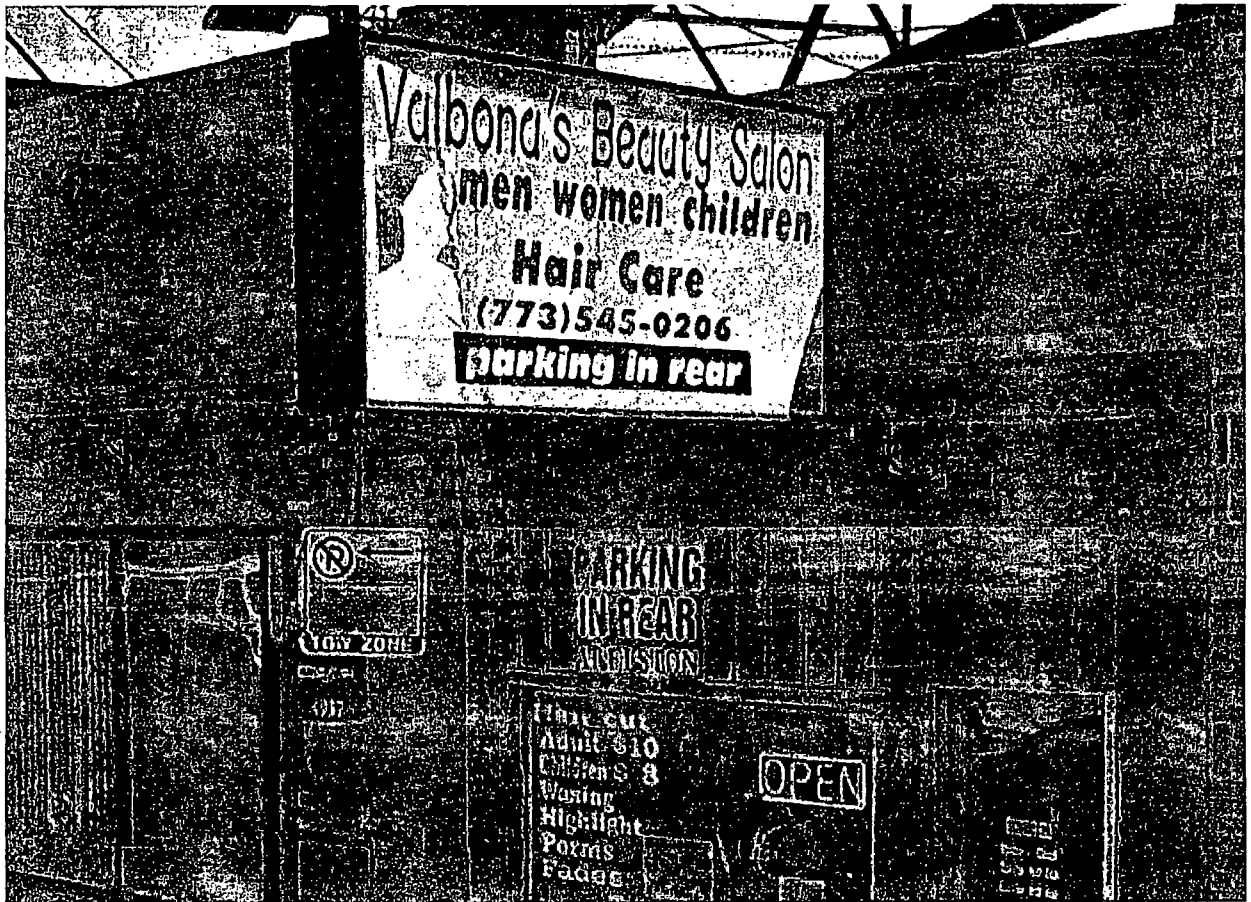



05/28/2014

Alderman **John Arena**
Ward # **45**
City of Chicago
City Hall, Room **305**
121 North LaSalle Street
Chicago, Illinois 60602

Re: An ordinance to use and maintain a portion of the public right-of-way for **one (1) sign(s)** for
VALBONA'S BEAUTY SALON, adjacent to the premises known as **4939 W. Foster Ave.**.

Dear Alderman **John Arena**:

The applicant referenced above has requested the use of the public right-of-way for a **sign(s)**. An ordinance has been prepared by the Department of Business Affairs and Consumer Protection – Small Business Center - Public Way Use Unit for presentation to the City Council. Because this request was made for properties located in your ward, as approved by you as per the attached, I respectfully request that you introduce the attached ordinance at the next City Council meeting.

If you have any questions regarding this ordinance, please contact Anthony Bertuca at (312) 744-5506.

Department of Business Affairs and Consumer Protection



City of Chicago



O2014-4802

Office of the City Clerk

Document Tracking Sheet

| | |
|---------------------------------|---|
| Meeting Date: | 5/28/2014 |
| Sponsor(s): | Cappleman (46) |
| Type: | Ordinance |
| Title: | Grant(s) of privilege in public way for Boost Mobile - banner |
| Committee(s) Assignment: | Committee on Transportation and Public Way |

ORDINANCE
BOOST MOBILE
Acct. No. 377244 - 1
Permit No. 1110764

Be It Ordained by the City Council of the City of Chicago:

SECTION 1. Permission and authority are hereby given and granted to BOOST MOBILE, upon the terms and subject to the conditions of this ordinance to construct, install, maintain and use one (1) Banner(s) projecting over the public right-of-way adjacent to its premises known as 4403 N. Broadway .

Said Banner(s) at N. Broadway measure(s):

One (1) at two point five (2.5) feet in length, and fourteen (14) feet in width for a total of thirty-five (35) square feet. Said banner shall be approximately nine (9) feet above grade level.

The location of said privilege shall be as shown on prints kept on file with the Department of Business Affairs and Consumer Protection and the Office of the City Clerk.

Said privilege shall be constructed in accordance with plans and specifications approved by the Zoning Department - Signs.

This grant of privilege in the public way shall be subject to the provisions of Section 10-28-015 and all other required provisions of the Municipal Code of Chicago.

The grantee shall pay to the City of Chicago as compensation for the privilege #1110764 herein granted the sum of seventy-five (\$75.00) per annum in advance.

A 25% penalty will be added for payments received after due date.

The permit holder agrees to hold the City of Chicago harmless for any damage, relocation or replacement costs associated with damage, relocation or removal of private property caused by the City performing work in the public way.

Authority herein given and granted for a period of five (5) years from and after Date of Passage.

Alderman _____

James Cappleman 46th Ward

BANNER

CROSS SECTION DETAIL

Installation Detail

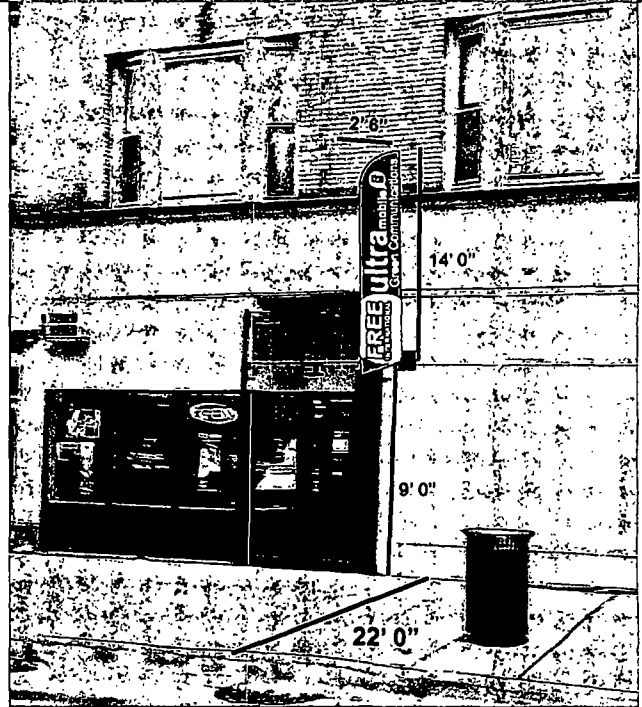
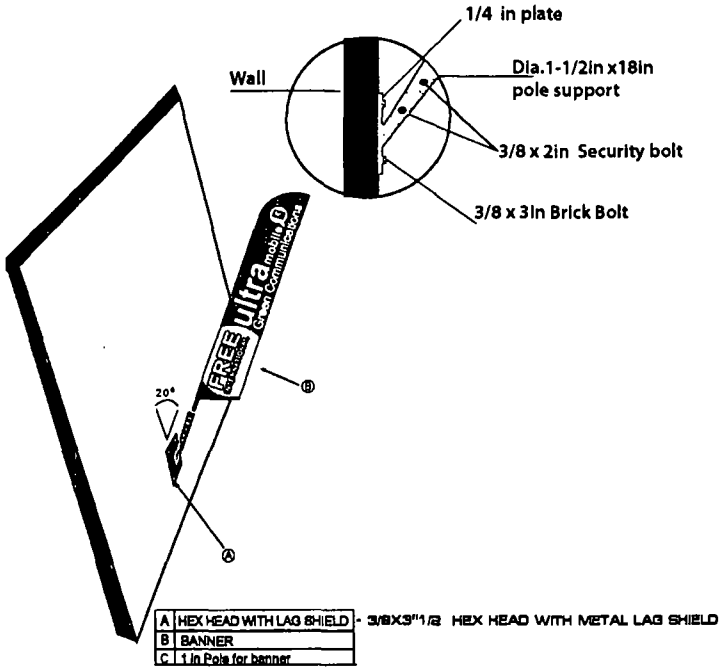

NOTE: Photo for representational purposes only. Signs are not to scale and may appear larger or smaller than shown.

Sign Erector:
PRO IMAGE
 2008 W. Chicago, Ave.
 Chicago, IL 60622
 Tel. 773 282 1111
 Fax. 773 282 1113

Location
 4403 N. Broadway
 Chicago, IL 60640

Client
Green Star
Communications

Description

- DOUBLE SIDED BANNER
- PRINT LETTERING WHITE, ORANGE & PURPLE
- 13 oz. NYLON BANNER
- WALL MOUNTED
- READS: FREE INTERNATIONAL , ULTRA MOBILE , Green Comm



05/28/2014

Alderman James Cappleman
Ward # 46
City of Chicago
City Hall, Room 300
121 North LaSalle Street
Chicago, Illinois 60602

Re: An ordinance to use and maintain a portion of the public right-of-way for **one (1) banner(s)** for **BOOST MOBILE**, adjacent to the premises known as **4403 N. Broadway**.

Dear Alderman **James Cappleman**:

The applicant referenced above has requested the use of the public right-of-way for a **banner(s)**. An ordinance has been prepared by the Department of Business Affairs and Consumer Protection – Small Business Center - Public Way Use Unit for presentation to the City Council. Because this request was made for properties located in your ward, as approved by you as per the attached, I respectfully request that you introduce the attached ordinance at the next City Council meeting.

If you have any questions regarding this ordinance, please contact Anthony Bertuca at (312) 744-5506.

Department of Business Affairs and Consumer Protection



City of Chicago



O2014-4804

Office of the City Clerk

Document Tracking Sheet

| | |
|---------------------------------|---|
| Meeting Date: | 5/28/2014 |
| Sponsor(s): | Cappleman (46) |
| Type: | Ordinance |
| Title: | Grant(s) of privilege in public way for Boost Mobile - sign |
| Committee(s) Assignment: | Committee on Transportation and Public Way |

ORDINANCE
BOOST MOBILE
Acct. No. 377244 - 1
Permit No. 1110765

Be It Ordained by the City Council of the City of Chicago:

SECTION 1. Permission and authority are hereby given and granted to BOOST MOBILE, upon the terms and subject to the conditions of this ordinance to maintain and use one (1) sign(s) projecting over the public right-of-way attached to its premises known as 4403 N. Broadway .

Said sign structure(s) measures as follows; along N. Broadway:
One (1) at eight (8) feet in length, five (5) feet in height and nine (9) feet above grade level.

The location of said privilege shall be as shown on prints kept on file with the Department of Business Affairs and Consumer Protection and the Office of the City Clerk.

Said privilege shall be constructed in accordance with plans and specifications approved by the Department of Transportation (Division of Project Development) and Zoning Department - Signs.

This grant of privilege in the public way shall be subject to the provisions of Section 10-28-015 and all other required provisions of the Municipal Code of Chicago.

The grantee shall pay to the City of Chicago as compensation for the privilege #1110765 herein granted the sum of three hundred (\$300.00) per annum in advance.

A 25% penalty will be added for payments received after due date.

The permit holder agrees to hold the City of Chicago harmless for any damage, relocation or replacement costs associated with damage, relocation or removal of private property caused by the City performing work in the public way.

Authority herein given and granted for a period of five (5) years from and after Date of Passage.

Alderman _____

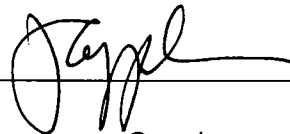

James Cappleman 46th Ward

Internally Illuminate Box Sign

CROSS SECTION DETAIL

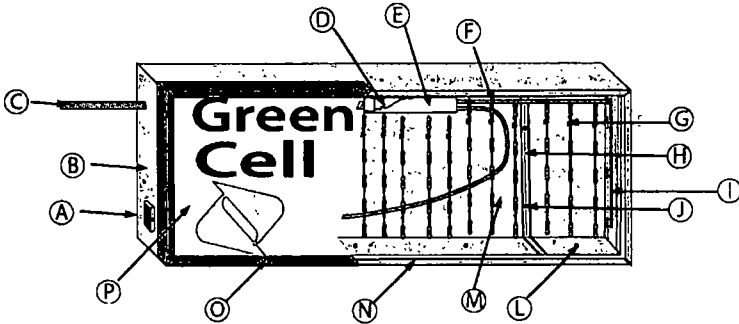

| | |
|---|---|
| A | listed disconnect switch |
| B | Aluminum side |
| C | primary electrical source |
| D | UL Listed Class 2, low voltage power supply |
| E | Power box |
| F | 1/2" greenfield |
| G | UL Listed Low Volt. Electronic L.E.D. lighting system |
| H | 1 1/2" x 1 1/2" x 3/8" "U" Steel Angle |
| I | Wire way box |
| J | Installation Holes |
| K | |
| L | Weep Holes |
| M | .080 Sheet Metal Back |
| N | 1 1/2" x 1 1/2" x 1/8" Steel Angle |
| O | 2" x 2" Aluminum Retainers |
| P | 3/16" White Lexon |

All electrical to be UL Listed

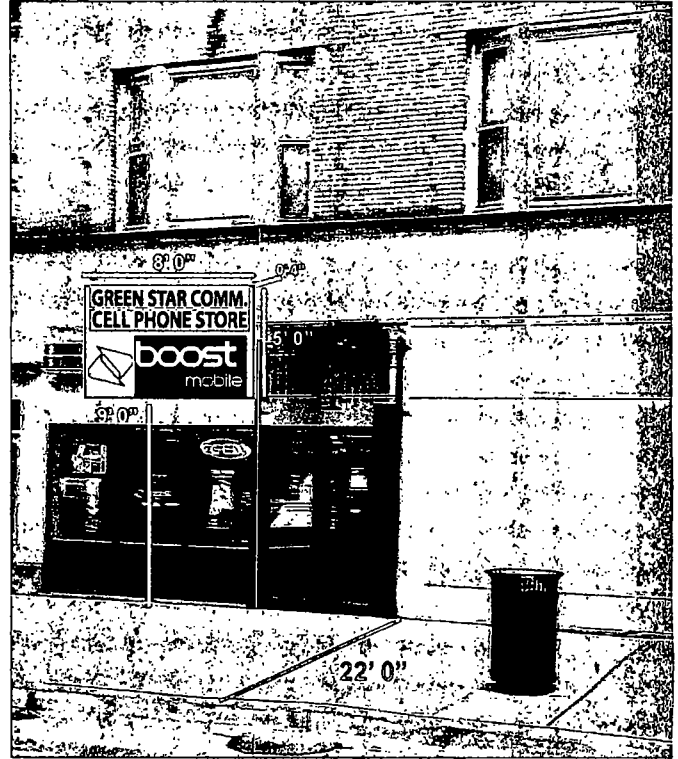

Sign Erector:

PRO IMAGE
 2006 W. Chicago, Ave.
 Chicago, IL 60622
 Tel. 773 292 1111
 Fax. 773 292 1113

Location

4403 N. Broadway
Chicago, IL. 60640

Client

Green Star
Communications

Description

- PRE- EXISTING FLAT/BOX ILLUMINATE SIGN
- WALL MOUNTED.
- VINYL LETTERING BLACK, WHITE & ORANGE
- 3/16 WHITE LEXON.
- INTERNALLY ILLUMINATE WITH WHITE LED
- READS: GREEN STAR COMM. CELL PHONE STORE BOOST MOBIL



05/28/2014

Alderman **James Cappleman**
Ward # **46**
City of Chicago
City Hall, Room **300**
121 North LaSalle Street
Chicago, Illinois 60602

Re: An ordinance to use and maintain a portion of the public right-of-way for **one (1) sign(s)** for **BOOST MOBILE**, adjacent to the premises known as **4403 N. Broadway** .

Dear Alderman **James Cappleman**:

The applicant referenced above has requested the use of the public right-of-way for a **sign(s)**. An ordinance has been prepared by the Department of Business Affairs and Consumer Protection – Small Business Center - Public Way Use Unit for presentation to the City Council. Because this request was made for properties located in your ward, as approved by you as per the attached, I respectfully request that you introduce the attached ordinance at the next City Council meeting.

If you have any questions regarding this ordinance, please contact Anthony Bertuca at (312) 744-5506.

Department of Business Affairs and Consumer Protection



City of Chicago



O2014-4805

Office of the City Clerk

Document Tracking Sheet

| | |
|---------------------------------|--|
| Meeting Date: | 5/28/2014 |
| Sponsor(s): | Cappleman (46) |
| Type: | Ordinance |
| Title: | Grant(s) of privilege in public way for Dearborn Food Mart |
| Committee(s) Assignment: | Committee on Transportation and Public Way |

ORDINANCE
Dearborn Food Mart
Acct. No. 257360 - 1
Permit No. 1112820

Be It Ordained by the City Council of the City of Chicago:

SECTION 1. Permission and authority are hereby given and granted to Dearborn Food Mart, upon the terms and subject to the conditions of this ordinance to maintain and use one (1) sign(s) projecting over the public right-of-way attached to its premises known as 3509 N. Halsted St..

Said sign structure(s) measures as follows; along N. Halsted Street:

One (1) at eight point five (8.5) feet in length, three (3) feet in height and eight (8) feet above grade level.

The location of said privilege shall be as shown on prints kept on file with the Department of Business Affairs and Consumer Protection and the Office of the City Clerk.

Said privilege shall be constructed in accordance with plans and specifications approved by the Department of Transportation (Division of Project Development) and Zoning Department - Signs.

This grant of privilege in the public way shall be subject to the provisions of Section 10-28-015 and all other required provisions of the Municipal Code of Chicago.

The grantee shall pay to the City of Chicago as compensation for the privilege #1112820 herein granted the sum of three hundred (\$300.00) per annum in advance.

A 25% penalty will be added for payments received after due date.

The permit holder agrees to hold the City of Chicago harmless for any damage, relocation or replacement costs associated with damage, relocation or removal of private property caused by the City performing work in the public way.

Authority herein given and granted for a period of five (5) years from and after 02/11/2014.

Alderman

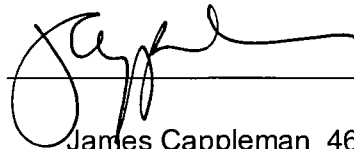

James Cappleman 46th Ward

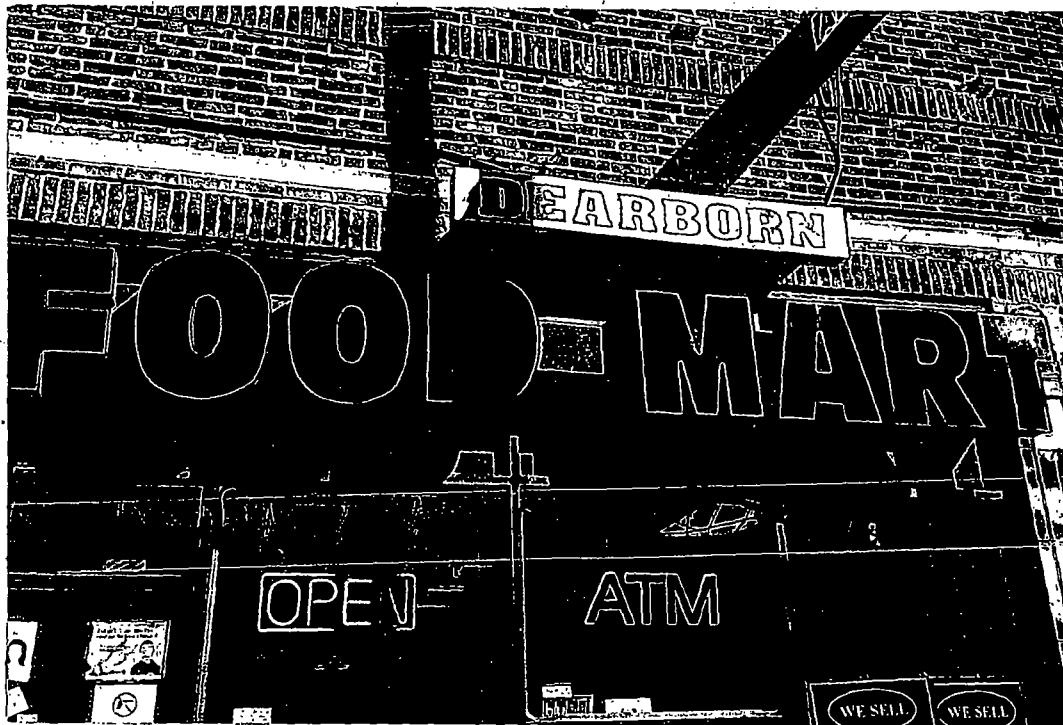



05/28/2014

Alderman **James Cappleman**
Ward # **46**
City of Chicago
City Hall, Room **300**
121 North LaSalle Street
Chicago, Illinois 60602

Re: An ordinance to use and maintain a portion of the public right-of-way for **one (1) sign(s)** for
Dearborn Food Mart, adjacent to the premises known as **3509 N. Halsted St.**

Dear Alderman **James Cappleman**:

The applicant referenced above has requested the use of the public right-of-way for a **sign(s)**. An ordinance has been prepared by the Department of Business Affairs and Consumer Protection – Small Business Center - Public Way Use Unit for presentation to the City Council. Because this request was made for properties located in your ward, as approved by you as per the attached, I respectfully request that you introduce the attached ordinance at the next City Council meeting.

If you have any questions regarding this ordinance, please contact Anthony Bertuca at (312) 744-5506.

Department of Business Affairs and Consumer Protection



City of Chicago



O2014-4806

Office of the City Clerk

Document Tracking Sheet

| | |
|---------------------------------|--|
| Meeting Date: | 5/28/2014 |
| Sponsor(s): | Cappleman (46) |
| Type: | Ordinance |
| Title: | Grant(s) of privilege in public way for Fifth Third Bank |
| Committee(s) Assignment: | Committee on Transportation and Public Way |

ORDINANCE
FIFTH THIRD BANK
Acct. No. 68597 - 17
Permit No. 1112939

Be It Ordained by the City Council of the City of Chicago:

SECTION 1. Permission and authority are hereby given and granted to FIFTH THIRD BANK, upon the terms and subject to the conditions of this ordinance to maintain and use one (1) sign(s) projecting over the public right-of-way attached to its premises known as 3601 N. Broadway .

Said sign structure(s) measures as follows; along N BROADWAY:

One (1) at five point zero eight (5.08) feet in length, five point one seven (5.17) feet in height and nine (9) feet above grade level.

The location of said privilege shall be as shown on prints kept on file with the Department of Business Affairs and Consumer Protection and the Office of the City Clerk.

Said privilege shall be constructed in accordance with plans and specifications approved by the Department of Transportation (Division of Project Development) and Zoning Department - Signs.

This grant of privilege in the public way shall be subject to the provisions of Section 10-28-015 and all other required provisions of the Municipal Code of Chicago.

The grantee shall pay to the City of Chicago as compensation for the privilege #1112939 herein granted the sum of three hundred (\$300.00) per annum in advance.

A 25% penalty will be added for payments received after due date.

The permit holder agrees to hold the City of Chicago harmless for any damage, relocation or replacement costs associated with damage, relocation or removal of private property caused by the City performing work in the public way.

Authority herein given and granted for a period of five (5) years from and after 05/13/2014.

Alderman

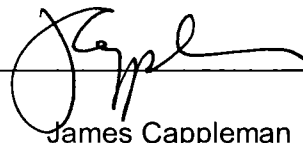
A handwritten signature in black ink, appearing to read 'James Cappleman', written over a horizontal line.

James Cappleman 46th Ward

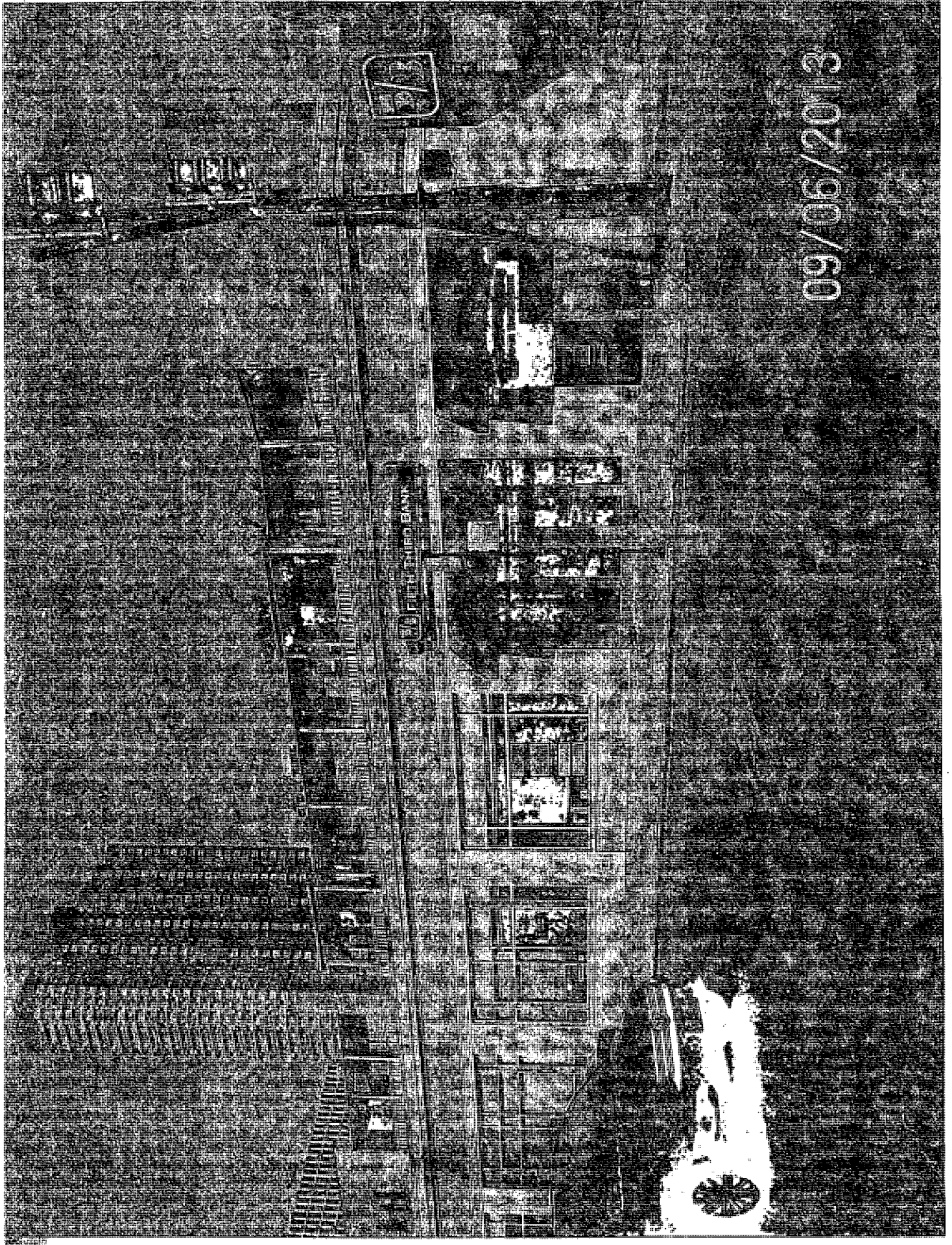



05/28/2014

Alderman **James Cappleman**
Ward # **46**
City of Chicago
City Hall, Room **300**
121 North LaSalle Street
Chicago, Illinois 60602

Re: An ordinance to use and maintain a portion of the public right-of-way for **one (1) sign(s)** for **FIFTH THIRD BANK**, adjacent to the premises known as **3601 N. Broadway** .

Dear Alderman **James Cappleman**:

The applicant referenced above has requested the use of the public right-of-way for a **sign(s)**. An ordinance has been prepared by the Department of Business Affairs and Consumer Protection – Small Business Center - Public Way Use Unit for presentation to the City Council. Because this request was made for properties located in your ward, as approved by you as per the attached, I respectfully request that you introduce the attached ordinance at the next City Council meeting.

If you have any questions regarding this ordinance, please contact Anthony Bertuca at (312) 744-5506.

Department of Business Affairs and Consumer Protection



City of Chicago



O2014-4808

Office of the City Clerk

Document Tracking Sheet

| | |
|---------------------------------|--|
| Meeting Date: | 5/28/2014 |
| Sponsor(s): | Cappleman (46) |
| Type: | Ordinance |
| Title: | Grant(s) of privilege in public way for Language Stars LLC |
| Committee(s) Assignment: | Committee on Transportation and Public Way |

ORDINANCE
LANGUAGE STARS LLC
Acct. No. 48132 - 10
Permit No. 1111621

Be It Ordained by the City Council of the City of Chicago:

SECTION 1. Permission and authority are hereby given and granted to LANGUAGE STARS LLC, upon the terms and subject to the conditions of this ordinance to maintain and use one (1) sign(s) projecting over the public right-of-way attached to its premises known as 4846 N. Clark St..

Said sign structure(s) measures as follows; along Clark:

One (1) at eight (8) feet in length, one point one seven (1.17) feet in height and thirteen point one seven (13.17) feet above grade level.

The location of said privilege shall be as shown on prints kept on file with the Department of Business Affairs and Consumer Protection and the Office of the City Clerk.

Said privilege shall be constructed in accordance with plans and specifications approved by the Department of Transportation (Division of Project Development) and Zoning Department - Signs.

This grant of privilege in the public way shall be subject to the provisions of Section 10-28-015 and all other required provisions of the Municipal Code of Chicago.

The grantee shall pay to the City of Chicago as compensation for the privilege #1111621 herein granted the sum of one hundred (\$100.00) per annum in advance.

A 25% penalty will be added for payments received after due date.

The permit holder agrees to hold the City of Chicago harmless for any damage, relocation or replacement costs associated with damage, relocation or removal of private property caused by the City performing work in the public way.

Authority herein given and granted for a period of five (5) years from and after Date of Passage.

Alderman  _____
James Cappleman 46th Ward

4846 N. Clark St.

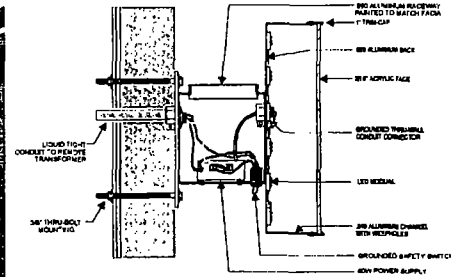

Typical U.L. Channel Letters with LEDs Mounted on Raceway
Not to scale

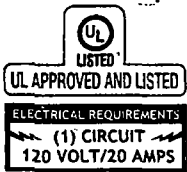
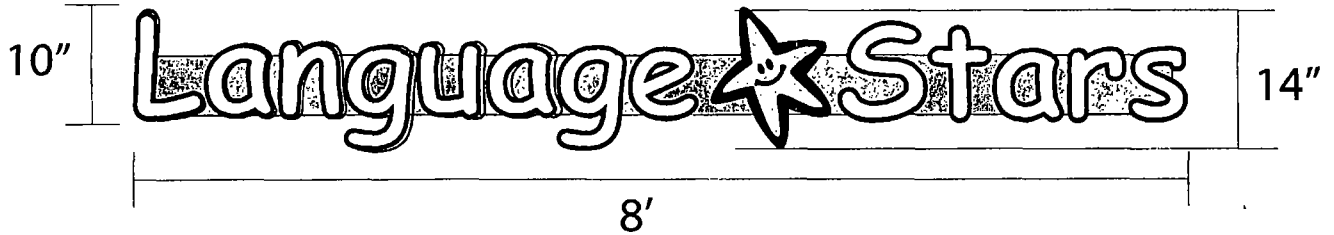

Sign: 9.33 Sq.Ft

RealNeon
Sbc Global INNOVATIONS
113 WEST OFFICIAL RD. ADDISON, IL 60101
PHONE: (630)543-0995 FAX: (630)543-9776
realneon@sbcglobal.net



05/28/2014

Alderman **James Cappleman**
Ward # **46**
City of Chicago
City Hall, Room **300**
121 North LaSalle Street
Chicago, Illinois 60602

Re: An ordinance to use and maintain a portion of the public right-of-way for **one (1) sign(s)** for
LANGUAGE STARS LLC, adjacent to the premises known as **4846 N. Clark St.**

Dear Alderman **James Cappleman**:

The applicant referenced above has requested the use of the public right-of-way for a **sign(s)**. An ordinance has been prepared by the Department of Business Affairs and Consumer Protection – Small Business Center - Public Way Use Unit for presentation to the City Council. Because this request was made for properties located in your ward, as approved by you as per the attached, I respectfully request that you introduce the attached ordinance at the next City Council meeting.

If you have any questions regarding this ordinance, please contact Anthony Bertuca at (312) 744-5506.

Department of Business Affairs and Consumer Protection



City of Chicago



O2014-4810

Office of the City Clerk

Document Tracking Sheet

| | |
|---------------------------------|--|
| Meeting Date: | 5/28/2014 |
| Sponsor(s): | Cappleman (46) |
| Type: | Ordinance |
| Title: | Grant(s) of privilege in public way for US Wireless Communications |
| Committee(s) Assignment: | Committee on Transportation and Public Way |

ORDINANCE
US WIRELESS COMMUNICATIONS
Acct. No. 377247 - 1
Permit No. 1110766

Be It Ordained by the City Council of the City of Chicago:

SECTION 1. Permission and authority are hereby given and granted to US WIRELESS COMMUNICATIONS, upon the terms and subject to the conditions of this ordinance to construct, install, maintain and use one (1) Banner(s) projecting over the public right-of-way adjacent to its premises known as 4404 N. Sheridan Rd..

Said Banner(s) at N. Sheridan Road measure(s):

One (1) at two point five (2.5) feet in length, and fourteen (14) feet in width for a total of thirty-five (35) square feet. Said banner is approximately nine (9) feet above grade level.

The location of said privilege shall be as shown on prints kept on file with the Department of Business Affairs and Consumer Protection and the Office of the City Clerk.

Said privilege shall be constructed in accordance with plans and specifications approved by the Zoning Department - Signs.

This grant of privilege in the public way shall be subject to the provisions of Section 10-28-015 and all other required provisions of the Municipal Code of Chicago.

The grantee shall pay to the City of Chicago as compensation for the privilege #1110766 herein granted the sum of seventy-five (\$75.00) per annum in advance.

A 25% penalty will be added for payments received after due date.

The permit holder agrees to hold the City of Chicago harmless for any damage, relocation or replacement costs associated with damage, relocation or removal of private property caused by the City performing work in the public way.

Authority herein given and granted for a period of five (5) years from and after Date of Passage.

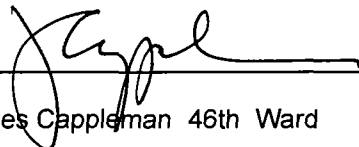
Alderman 
James Cappelman 46th Ward

BANNER

CROSS SECTION DETAIL

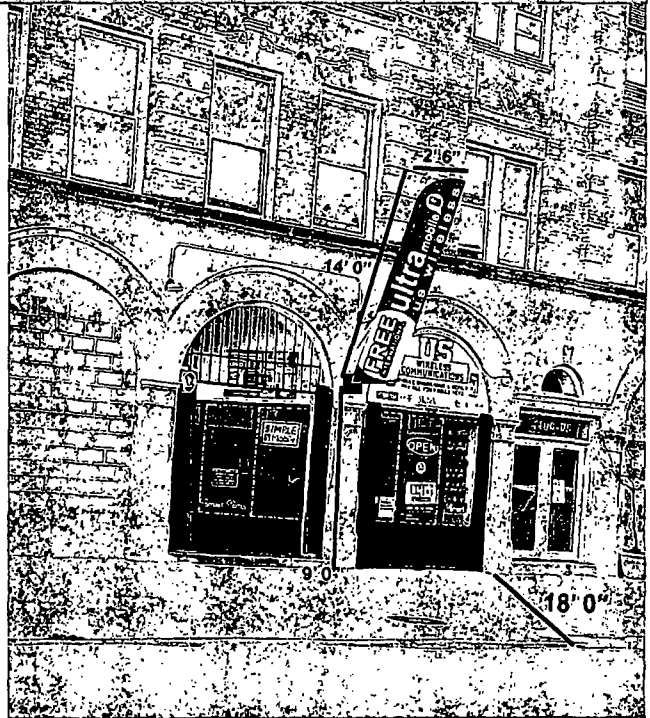
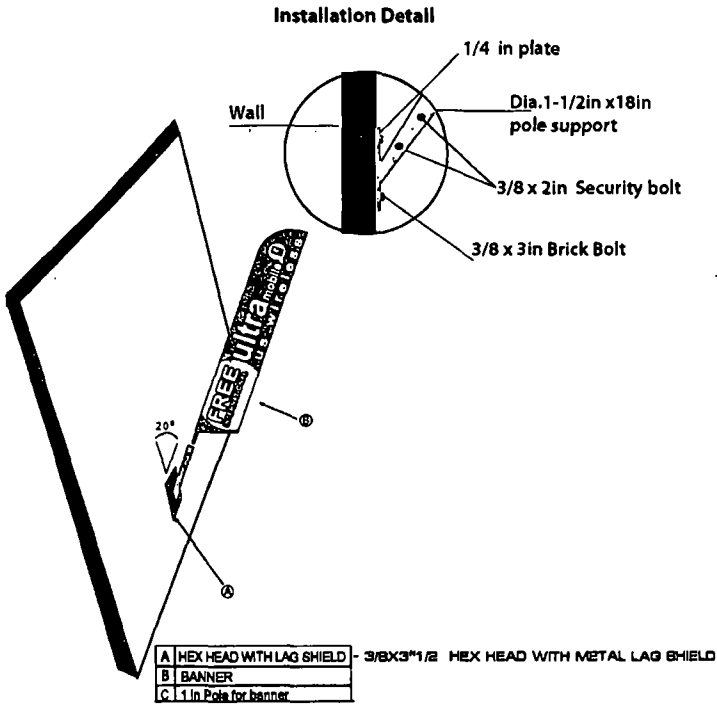

NOTE: Photo for representational purposes only.
Signs are not to scale and may appear larger or smaller than shown.

Sign Erector:
PRO IMAGE
 2008 W. Chicago, Ave.
 Chicago, IL 60622
 Tel. 773 292 1111
 Fax. 773 292 1113

Location
 4404 N. Sheridan rd
 Chicago, IL 60640

Client
 US WIRELESS COMMUNICATIONS

Description

- DOUBLE SIDED BANNER
- PRINT LETTERING WHITE, ORANGE & PURPLE
- 13 oz. NYLON BANNER
- WALL MOUNTED
- READS: FREE INTERNATIONAL , ULTRA MOBILE , US WIRELESS



05/28/2014

Alderman **James Cappleman**
Ward # **46**
City of Chicago
City Hall, Room **300**
121 North LaSalle Street
Chicago, Illinois 60602

Re: An ordinance to use and maintain a portion of the public right-of-way for **one (1) banner(s)** for **US WIRELESS COMMUNICATIONS**, adjacent to the premises known as **4404 N. Sheridan Rd.**

Dear Alderman **James Cappleman**:

The applicant referenced above has requested the use of the public right-of-way for a **banner(s)**. An ordinance has been prepared by the Department of Business Affairs and Consumer Protection – Small Business Center - Public Way Use Unit for presentation to the City Council. Because this request was made for properties located in your ward, as approved by you as per the attached, I respectfully request that you introduce the attached ordinance at the next City Council meeting.

If you have any questions regarding this ordinance, please contact Anthony Bertuca at (312) 744-5506.

Department of Business Affairs and Consumer Protection



City of Chicago



O2014-4764

Office of the City Clerk
Document Tracking Sheet

| | |
|---------------------------------|--|
| Meeting Date: | 5/28/2014 |
| Sponsor(s): | Pawar (47) |
| Type: | Ordinance |
| Title: | Grant(s) of privilege in public way for ATI Physical Therapy |
| Committee(s) Assignment: | Committee on Transportation and Public Way |

ORDINANCE
ATI Physical Therapy
Acct. No. 285488 - 9
Permit No. 1112321

Be It Ordained by the City Council of the City of Chicago:

SECTION 1. Permission and authority are hereby given and granted to ATI Physical Therapy, upon the terms and subject to the conditions of this ordinance to maintain and use one (1) sign(s) projecting over the public right-of-way attached to its premises known as 4620 N. Clark St..

Said sign structure(s) measures as follows; along Clark:
One (1) at twenty-three (23) feet in length, two point five eight (2.58) feet in height and eleven (11) feet above grade level.

The location of said privilege shall be as shown on prints kept on file with the Department of Business Affairs and Consumer Protection and the Office of the City Clerk.

Said privilege shall be constructed in accordance with plans and specifications approved by the Department of Transportation (Division of Project Development) and Zoning Department - Signs.

This grant of privilege in the public way shall be subject to the provisions of Section 10-28-015 and all other required provisions of the Municipal Code of Chicago.

The grantee shall pay to the City of Chicago as compensation for the privilege #1112321 herein granted the sum of three hundred (\$300.00) per annum in advance.

A 25% penalty will be added for payments received after due date.

The permit holder agrees to hold the City of Chicago harmless for any damage, relocation or replacement costs associated with damage, relocation or removal of private property caused by the City performing work in the public way.

Authority herein given and granted for a period of five (5) years from and after Date of Passage.

Alderman 
Ameya Pawar 47th Ward

© Aurora Sign Co, Inc 2014

AURORA SIGN CO.

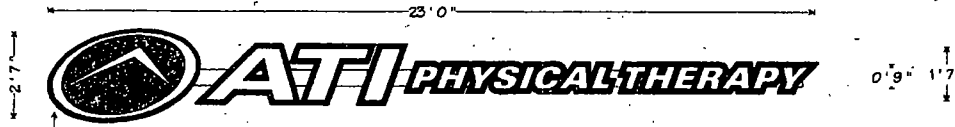

ELECTRICAL DISCONNECT

INDIVIDUAL ILLUMINATED LETTERS WITH BACKER ON RACEWAY - 2 REQUIRED

FABRICATE AND INSTALL LETTERS OF ALUMINUM AND ACRYLIC.
 FACES TO BE WHITE ACRYLIC. LOGO TO HAVE COPY APPLIED FIRST SURFACE.
 TRIMCAP TO BE BLACK. RETURNS TO BE BLACK.
 BACKER TO BE BLACK.
 RACEWAY TO BE PAINTED TO MATCH WALL.
 ALL EXPOSED METAL SURFACES TO BE COATED WITH ACRYLIC POLYURETHANE.
 INTERNAL ILLUMINATION TO BE WHITE LEDS.
 SCALE - 3/8" = 1"

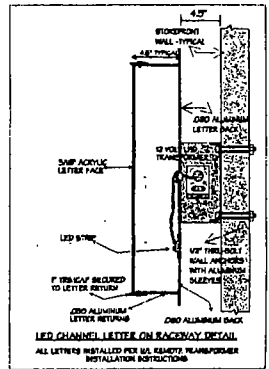

INSTALLATION INSTRUCTIONS

REMOVE EXISTING SIGNS AND DISPOSE
 INSTALL IN SAME AREAS AS SHOWN
 CONNECT TO ELECTRICAL SERVICE
 TO BE PROVIDED BY OTHERS
 PRIOR TO INSTALL.

SIGN TO BE UL LISTED

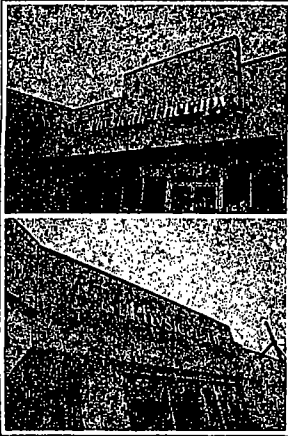

Private Property

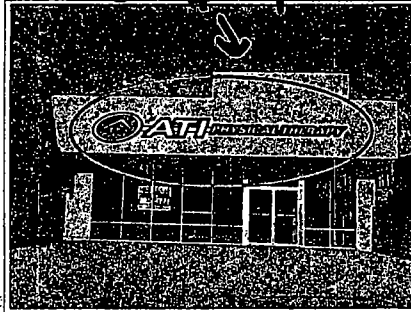

Public Way

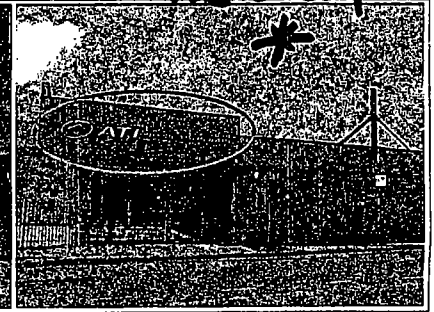

| | | | | | | | |
|--|--|------------------------------------|------------------------|--------------------|--------------------------------|--------|------------|
| 1100 Route 34 Aurora, Illinois 60504 630 898 5900 office 630 898 6021 fax | Prepared For: ATI PHYSICAL THERAPY | Address: 4620 N CLARK ST | Draw: 214049 | Sheet: 1 | Design Date: 2/11/14 | Rev 3: | Submitted: |
| | Location Name: ANDERSONVILLE | City/State: CHICAGO, IL | Rev 1: | | Rev 4: | | Color: |
| | | | Rev 2: | | Rev 5: | | Notes: |

NOTE: THIS DRAWING IS THE PROPERTY OF AURORA SIGN CO. IT IS NOT TO BE REPRODUCED, COPIED, OR EXHIBITED IN ANY FASHION WITHOUT WRITTEN CONSENT FROM AURORA SIGN CO. CHARGES OF UP TO \$2000.00 WILL BE ASSESSED FOR ANY MIS-USE OF THESE DRAWINGS.



05/28/2014

Alderman **Ameya Pawar**
Ward # **47**
City of Chicago
City Hall, Room **300**
121 North LaSalle Street
Chicago, Illinois 60602

Re: An ordinance to use and maintain a portion of the public right-of-way for **one (1) sign(s)** for **ATI Physical Therapy**, adjacent to the premises known as **4620 N. Clark St.**

Dear Alderman **Ameya Pawar**:

The applicant referenced above has requested the use of the public right-of-way for a **sign(s)**. An ordinance has been prepared by the Department of Business Affairs and Consumer Protection – Small Business Center - Public Way Use Unit for presentation to the City Council. Because this request was made for properties located in your ward, as approved by you as per the attached, I respectfully request that you introduce the attached ordinance at the next City Council meeting.

If you have any questions regarding this ordinance, please contact Anthony Bertuca at (312) 744-5506.

Department of Business Affairs and Consumer Protection



City of Chicago



O2014-4765

Office of the City Clerk

Document Tracking Sheet

| | |
|---------------------------------|---|
| Meeting Date: | 5/28/2014 |
| Sponsor(s): | Pawar (47) |
| Type: | Ordinance |
| Title: | Grant(s) of privilege in public way for Domestic Linen Supply Co., Inc. |
| Committee(s) Assignment: | Committee on Transportation and Public Way |

ORDINANCE
DOMESTIC LINEN SUPPLY CO,INC
Acct. No. 3374 - 1
Permit No. 1113109

Be It Ordained by the City Council of the City of Chicago:

SECTION 1. Permission and authority are hereby given and granted to DOMESTIC LINEN SUPPLY CO,INC, upon the terms and subject to the conditions of this ordinance to maintain and use one (1) sign(s) projecting over the public right-of-way attached to its premises known as 4131 N. Ravenswood Ave..

Said sign structure(s) measures as follows; along N. RAVENSWOOD:
One (1) at five (5) feet in length, three (3) feet in height and twenty (20) feet above grade level.

The location of said privilege shall be as shown on prints kept on file with the Department of Business Affairs and Consumer Protection and the Office of the City Clerk.

Said privilege shall be constructed in accordance with plans and specifications approved by the Department of Transportation (Division of Project Development) and Zoning Department - Signs.

This grant of privilege in the public way shall be subject to the provisions of Section 10-28-015 and all other required provisions of the Municipal Code of Chicago.

The grantee shall pay to the City of Chicago as compensation for the privilege #1113109 herein granted the sum of one hundred (\$100.00) per annum in advance.

A 25% penalty will be added for payments received after due date.

The permit holder agrees to hold the City of Chicago harmless for any damage, relocation or replacement costs associated with damage, relocation or removal of private property caused by the City performing work in the public way.

Authority herein given and granted for a period of five (5) years from and after 05/13/2014.

Alderman 
Ameya Pawar 47th Ward

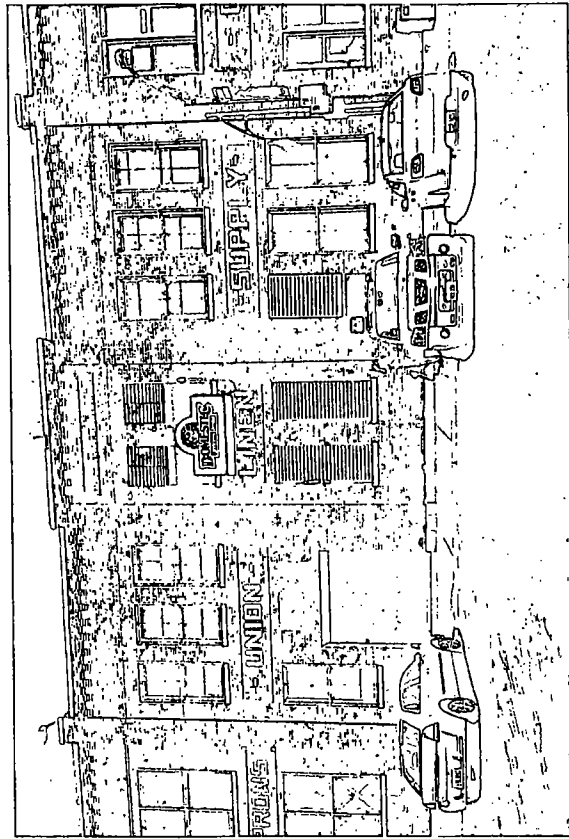



05/28/2014

Alderman **Ameya Pawar**
Ward # 47
City of Chicago
City Hall, Room 300
121 North LaSalle Street
Chicago, Illinois 60602

Re: An ordinance to use and maintain a portion of the public right-of-way for **one (1) sign(s)** for **DOMESTIC LINEN SUPPLY CO,INC**, adjacent to the premises known as **4131 N. Ravenswood Ave.**.

Dear Alderman **Ameya Pawar**:

The applicant referenced above has requested the use of the public right-of-way for a **sign(s)**. An ordinance has been prepared by the Department of Business Affairs and Consumer Protection – Small Business Center - Public Way Use Unit for presentation to the City Council. Because this request was made for properties located in your ward, as approved by you as per the attached, I respectfully request that you introduce the attached ordinance at the next City Council meeting.

If you have any questions regarding this ordinance, please contact Anthony Bertuca at (312) 744-5506.

Department of Business Affairs and Consumer Protection



City of Chicago



O2014-4767

Office of the City Clerk

Document Tracking Sheet

| | |
|---------------------------------|--|
| Meeting Date: | 5/28/2014 |
| Sponsor(s): | Pawar (47) |
| Type: | Ordinance |
| Title: | Grant(s) of privilege in public way for Half Acre Beer Company |
| Committee(s) Assignment: | Committee on Transportation and Public Way |

ORDINANCE
HALF ACRE BEER COMPANY
Acct. No. 339641 - 1
Permit No. 1112920

Be It Ordained by the City Council of the City of Chicago:

SECTION 1. Permission and authority are hereby given and granted to HALF ACRE BEER COMPANY, upon the terms and subject to the conditions of this ordinance to maintain and use two (2) sign(s) projecting over the public right-of-way attached to its premises known as 4257 N. Lincoln Ave..

Said sign structure(s) measures as follows; along N LINCOLN AVE:

One (1) at twenty-three point six seven (23.67) feet in length, four point six seven (4.67) feet in height and ten (10) feet above grade level.

Said sign structure(s) measures as follows; along N LINCOLN AVE:

One (1) at four (4) feet in length, four (4) feet in height and twenty-two (22) feet above grade level.

The location of said privilege shall be as shown on prints kept on file with the Department of Business Affairs and Consumer Protection and the Office of the City Clerk.

Said privilege shall be constructed in accordance with plans and specifications approved by the Department of Transportation (Division of Project Development) and Zoning Department - Signs.

This grant of privilege in the public way shall be subject to the provisions of Section 10-28-015 and all other required provisions of the Municipal Code of Chicago.

The grantee shall pay to the City of Chicago as compensation for the privilege #1112920 herein granted the sum of four hundred (\$400.00) per annum in advance.

A 25% penalty will be added for payments received after due date.

The permit holder agrees to hold the City of Chicago harmless for any damage, relocation or replacement costs associated with damage, relocation or removal of private property caused by the City performing work in the public way.

Authority herein given and granted for a period of five (5) years from and after 05/13/2014.

Alderman



Ameya Pawar 47th Ward





05/28/2014

Alderman Ameya Pawar
Ward # 47
City of Chicago
City Hall, Room 300
121 North LaSalle Street
Chicago, Illinois 60602

Re: An ordinance to use and maintain a portion of the public right-of-way for **two (2) sign(s)** for **HALF ACRE BEER COMPANY**, adjacent to the premises known as **4257 N. Lincoln Ave.**.

Dear Alderman **Ameya Pawar**:

The applicant referenced above has requested the use of the public right-of-way for a **sign(s)**. An ordinance has been prepared by the Department of Business Affairs and Consumer Protection – Small Business Center - Public Way Use Unit for presentation to the City Council. Because this request was made for properties located in your ward, as approved by you as per the attached, I respectfully request that you introduce the attached ordinance at the next City Council meeting.

If you have any questions regarding this ordinance, please contact Anthony Bertuca at (312) 744-5506.

Department of Business Affairs and Consumer Protection



City of Chicago



O2014-4768

Office of the City Clerk

Document Tracking Sheet

| | |
|---------------------------------|--|
| Meeting Date: | 5/28/2014 |
| Sponsor(s): | Pawar (47) |
| Type: | Ordinance |
| Title: | Grant(s) of privilege in public way for Julius Meini |
| Committee(s) Assignment: | Committee on Transportation and Public Way |

ORDINANCE
JULIUS MEINL
Acct. No. 254059 - 3
Permit No. 1112821

Be It Ordained by the City Council of the City of Chicago:

SECTION 1. Permission and authority are hereby given and granted to JULIUS MEINL, upon the terms and subject to the conditions of this ordinance to maintain and use two (2) sign(s) projecting over the public right-of-way attached to its premises known as 4363 N. Lincoln Ave..

Said sign structure(s) measures as follows; along N. Lincoln:

One (1) at sixteen (16) feet in length, point six six (.66) feet in height and nine (9) feet above grade level.

Said sign structure(s) measures as follows; along W. Montrose:

One (1) at sixteen (16) feet in length, point six six (.66) feet in height and nine (9) feet above grade level.

The location of said privilege shall be as shown on prints kept on file with the Department of Business Affairs and Consumer Protection and the Office of the City Clerk.

Said privilege shall be constructed in accordance with plans and specifications approved by the Department of Transportation (Division of Project Development) and Zoning Department - Signs.

This grant of privilege in the public way shall be subject to the provisions of Section 10-28-015 and all other required provisions of the Municipal Code of Chicago.

The grantee shall pay to the City of Chicago as compensation for the privilege #1112821 herein granted the sum of one hundred seventy-five (\$175.00) per annum in advance.

A 25% penalty will be added for payments received after due date.

The permit holder agrees to hold the City of Chicago harmless for any damage, relocation or replacement costs associated with damage, relocation or removal of private property caused by the City performing work in the public way.

Authority herein given and granted for a period of five (5) years from and after 04/22/2014.

Alderman 
Ameya Pawar 47th Ward

**Julius Meini
4363 N. Lincoln Ave
Chicago, IL 60618**

**Montrose St
side**

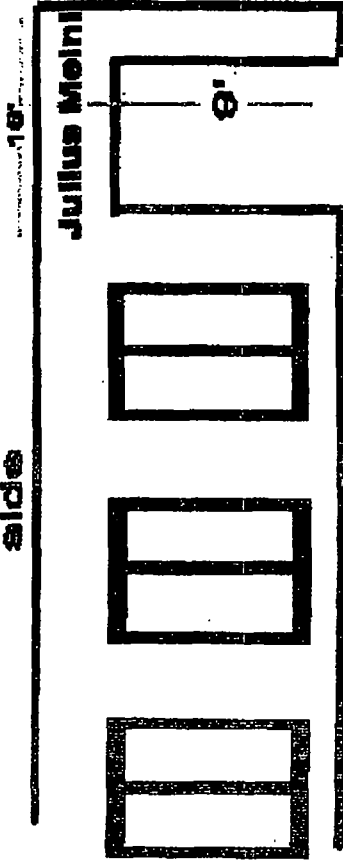

sidewalk

**Lincoln Ave
side**

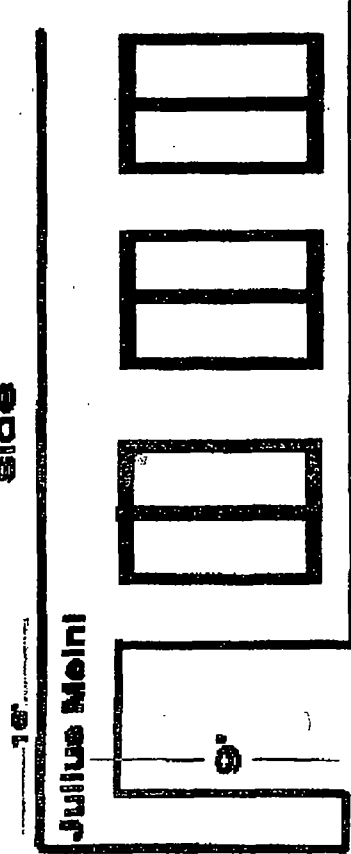

sidewalk

**Julius Meini
Side View
of Signs**

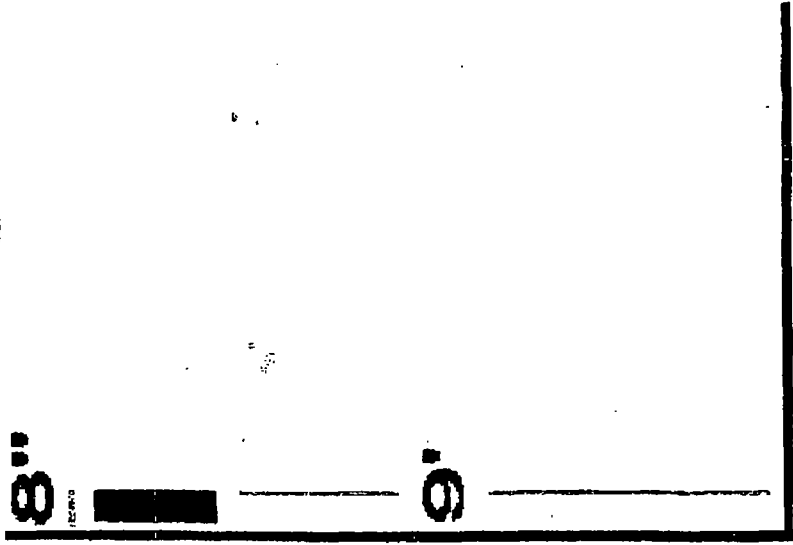

sidewalk



05/28/2014

Alderman **Ameya Pawar**
Ward # **47**
City of Chicago
City Hall, Room **300**
121 North LaSalle Street
Chicago, Illinois 60602

Re: An ordinance to use and maintain a portion of the public right-of-way for **two (2) sign(s)** for **JULIUS MEINL**, adjacent to the premises known as **4363 N. Lincoln Ave.**.

Dear Alderman **Ameya Pawar**:

The applicant referenced above has requested the use of the public right-of-way for a **sign(s)**. An ordinance has been prepared by the Department of Business Affairs and Consumer Protection – Small Business Center - Public Way Use Unit for presentation to the City Council. Because this request was made for properties located in your ward, as approved by you as per the attached, I respectfully request that you introduce the attached ordinance at the next City Council meeting.

If you have any questions regarding this ordinance, please contact Anthony Bertuca at (312) 744-5506.

Department of Business Affairs and Consumer Protection



City of Chicago



O2014-4770

Office of the City Clerk

Document Tracking Sheet

| | |
|---------------------------------|--|
| Meeting Date: | 5/28/2014 |
| Sponsor(s): | Pawar (47) |
| Type: | Ordinance |
| Title: | Grant(s) of privilege in public way for Mrs Murphys and Sons Irish Bistro |
| Committee(s) Assignment: | Committee on Transportation and Public Way |

ORDINANCE
MRS MURPHYS AND SONS IRISH BISTRO
Acct. No. 274122 - 1
Permit No. 1113112

Be It Ordained by the City Council of the City of Chicago:

SECTION 1. Permission and authority are hereby given and granted to MRS MURPHYS AND SONS IRISH BISTRO, upon the terms and subject to the conditions of this ordinance to maintain and use one (1) sign(s) projecting over the public right-of-way attached to its premises known as 3905 N. Lincoln Ave..

Said sign structure(s) measures as follows; along N. LINCOLN:
One (1) at six point six seven (6.67) feet in length, three (3) feet in height and ten (10) feet above grade level.

The location of said privilege shall be as shown on prints kept on file with the Department of Business Affairs and Consumer Protection and the Office of the City Clerk.

Said privilege shall be constructed in accordance with plans and specifications approved by the Department of Transportation (Division of Project Development) and Zoning Department - Signs.

This grant of privilege in the public way shall be subject to the provisions of Section 10-28-015 and all other required provisions of the Municipal Code of Chicago.

The grantee shall pay to the City of Chicago as compensation for the privilege #1113112 herein granted the sum of one hundred (\$100.00) per annum in advance.

A 25% penalty will be added for payments received after due date.

The permit holder agrees to hold the City of Chicago harmless for any damage, relocation or replacement costs associated with damage, relocation or removal of private property caused by the City performing work in the public way.

Authority herein given and granted for a period of five (5) years from and after 05/13/2014.

Alderman  _____

Ameya Pawar 47th Ward

3905 N LINCOLN AVE.
SIGN

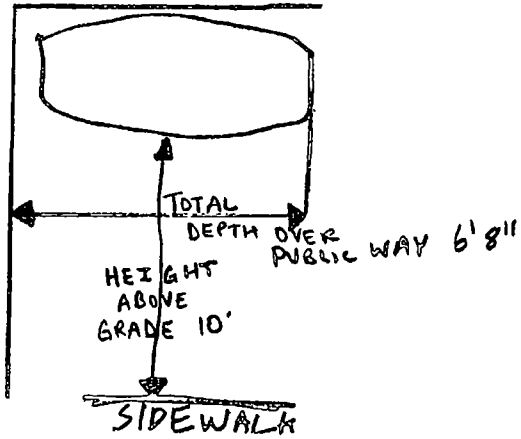
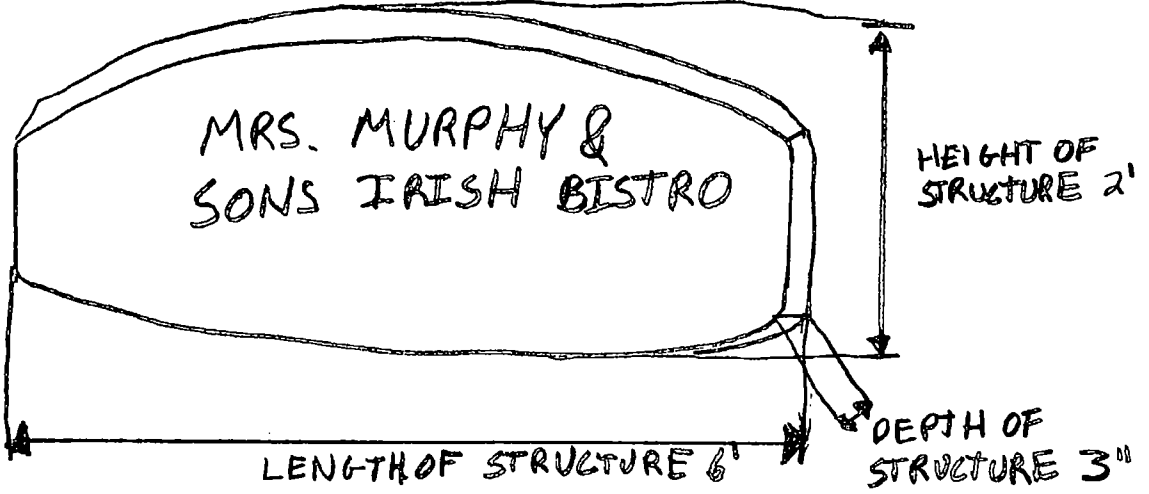



05/28/2014

Alderman **Ameya Pawar**
Ward # **47**
City of Chicago
City Hall, Room **300**
121 North LaSalle Street
Chicago, Illinois 60602

Re: An ordinance to use and maintain a portion of the public right-of-way for **one (1) sign(s)** for **MRS MURPHYS AND SONS IRISH BISTRO**, adjacent to the premises known as **3905 N. Lincoln Ave.**.

Dear Alderman **Ameya Pawar**:

The applicant referenced above has requested the use of the public right-of-way for a **sign(s)**. An ordinance has been prepared by the Department of Business Affairs and Consumer Protection – Small Business Center - Public Way Use Unit for presentation to the City Council. Because this request was made for properties located in your ward, as approved by you as per the attached, I respectfully request that you introduce the attached ordinance at the next City Council meeting.

If you have any questions regarding this ordinance, please contact Anthony Bertuca at (312) 744-5506.

Department of Business Affairs and Consumer Protection



City of Chicago



O2014-4771

Office of the City Clerk

Document Tracking Sheet

| | |
|---------------------------------|--|
| Meeting Date: | 5/28/2014 |
| Sponsor(s): | Pawar (47) |
| Type: | Ordinance |
| Title: | Grant(s) of privilege in public way for State Farm Insurance |
| Committee(s) Assignment: | Committee on Transportation and Public Way |

ORDINANCE
STATE FARM INSURENCE
Acct. No. 306800 - 1
Permit No. 1113079

Be It Ordained by the City Council of the City of Chicago:

SECTION 1. Permission and authority are hereby given and granted to STATE FARM INSURENCE, upon the terms and subject to the conditions of this ordinance to maintain and use one (1) sign(s) projecting over the public right-of-way attached to its premises known as 1428 W. Irving Park Rd..

Said sign structure(s) measures as follows; along W IRVING PARK RD:
One (1) at ten (10) feet in length, one point five (1.5) feet in height and eleven (11) feet above grade level.

The location of said privilege shall be as shown on prints kept on file with the Department of Business Affairs and Consumer Protection and the Office of the City Clerk.

Said privilege shall be constructed in accordance with plans and specifications approved by the Department of Transportation (Division of Project Development) and Zoning Department - Signs.

This grant of privilege in the public way shall be subject to the provisions of Section 10-28-015 and all other required provisions of the Municipal Code of Chicago.

The grantee shall pay to the City of Chicago as compensation for the privilege #1113079 herein granted the sum of one hundred (\$100.00) per annum in advance.

A 25% penalty will be added for payments received after due date.

The permit holder agrees to hold the City of Chicago harmless for any damage, relocation or replacement costs associated with damage, relocation or removal of private property caused by the City performing work in the public way.

Authority herein given and granted for a period of five (5) years from and after 04/22/2014.

Alderman



Ameya Pawar 47th Ward

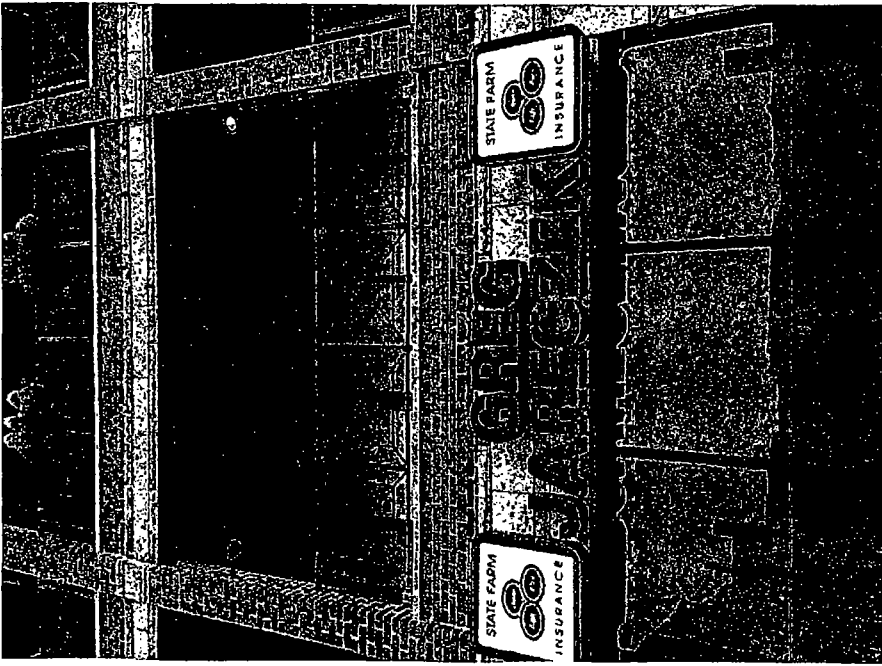

1428 W. Irving Park Rd.

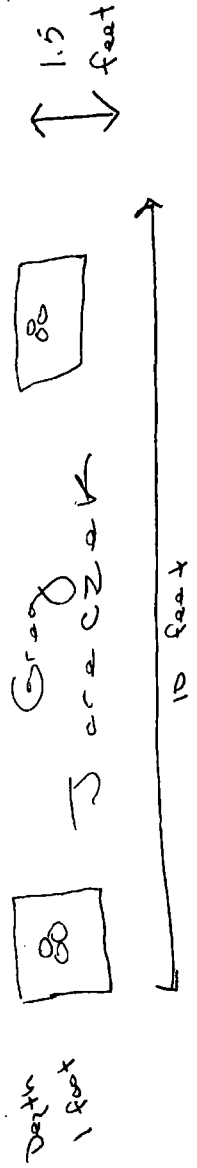

Depth 1 foot

Height above grade = 11 feet
 Sidewalk width = 7 feet, 2 inches



05/28/2014

Alderman **Ameya Pawar**
Ward # 47
City of Chicago
City Hall, Room 300
121 North LaSalle Street
Chicago, Illinois 60602

Re: An ordinance to use and maintain a portion of the public right-of-way for **one (1) sign(s)** for **STATE FARM INSURENCE**, adjacent to the premises known as **1428 W. Irving Park Rd.**

Dear Alderman **Ameya Pawar**:

The applicant referenced above has requested the use of the public right-of-way for a **sign(s)**. An ordinance has been prepared by the Department of Business Affairs and Consumer Protection – Small Business Center - Public Way Use Unit for presentation to the City Council. Because this request was made for properties located in your ward, as approved by you as per the attached, I respectfully request that you introduce the attached ordinance at the next City Council meeting.

If you have any questions regarding this ordinance, please contact Anthony Bertuca at (312) 744-5506.

Department of Business Affairs and Consumer Protection



City of Chicago



O2014-4773

Office of the City Clerk

Document Tracking Sheet

| | |
|---------------------------------|---|
| Meeting Date: | 5/28/2014 |
| Sponsor(s): | Pawar (47) |
| Type: | Ordinance |
| Title: | Grant(s) of privilege in public way for Strongbox |
| Committee(s) Assignment: | Committee on Transportation and Public Way |

ORDINANCE
STRONGBOX
Acct. No. 53277 - 1
Permit No. 1113035

Be It Ordained by the City Council of the City of Chicago:

SECTION 1. Permission and authority are hereby given and granted to STRONGBOX, upon the terms and subject to the conditions of this ordinance to maintain and use two (2) sign(s) projecting over the public right-of-way attached to its premises known as 1650 W. Irving Park Rd..

Said sign structure(s) measures as follows; along W IRVING PARK RD:

One (1) at twelve (12) feet in length, eight point two five (8.25) feet in height and seventeen point six seven (17.67) feet above grade level.

Said sign structure(s) measures as follows; along N PAULINA:

One (1) at eight (8) feet in length, four point two five (4.25) feet in height and thirteen point one seven (13.17) feet above grade level.

The location of said privilege shall be as shown on prints kept on file with the Department of Business Affairs and Consumer Protection and the Office of the City Clerk.

Said privilege shall be constructed in accordance with plans and specifications approved by the Department of Transportation (Division of Project Development) and Zoning Department - Signs.

This grant of privilege in the public way shall be subject to the provisions of Section 10-28-015 and all other required provisions of the Municipal Code of Chicago.

The grantee shall pay to the City of Chicago as compensation for the privilege #1113035 herein granted the sum of six hundred (\$600.00) per annum in advance.

A 25% penalty will be added for payments received after due date.

The permit holder agrees to hold the City of Chicago harmless for any damage, relocation or replacement costs associated with damage, relocation or removal of private property caused by the City performing work in the public way.

Authority herein given and granted for a period of five (5) years from and after 05/13/2014.

Alderman



Ameya Pawar 47th Ward

Strongbox Storage
1650 West Irving Park Road
Chicago, IL

IRVING

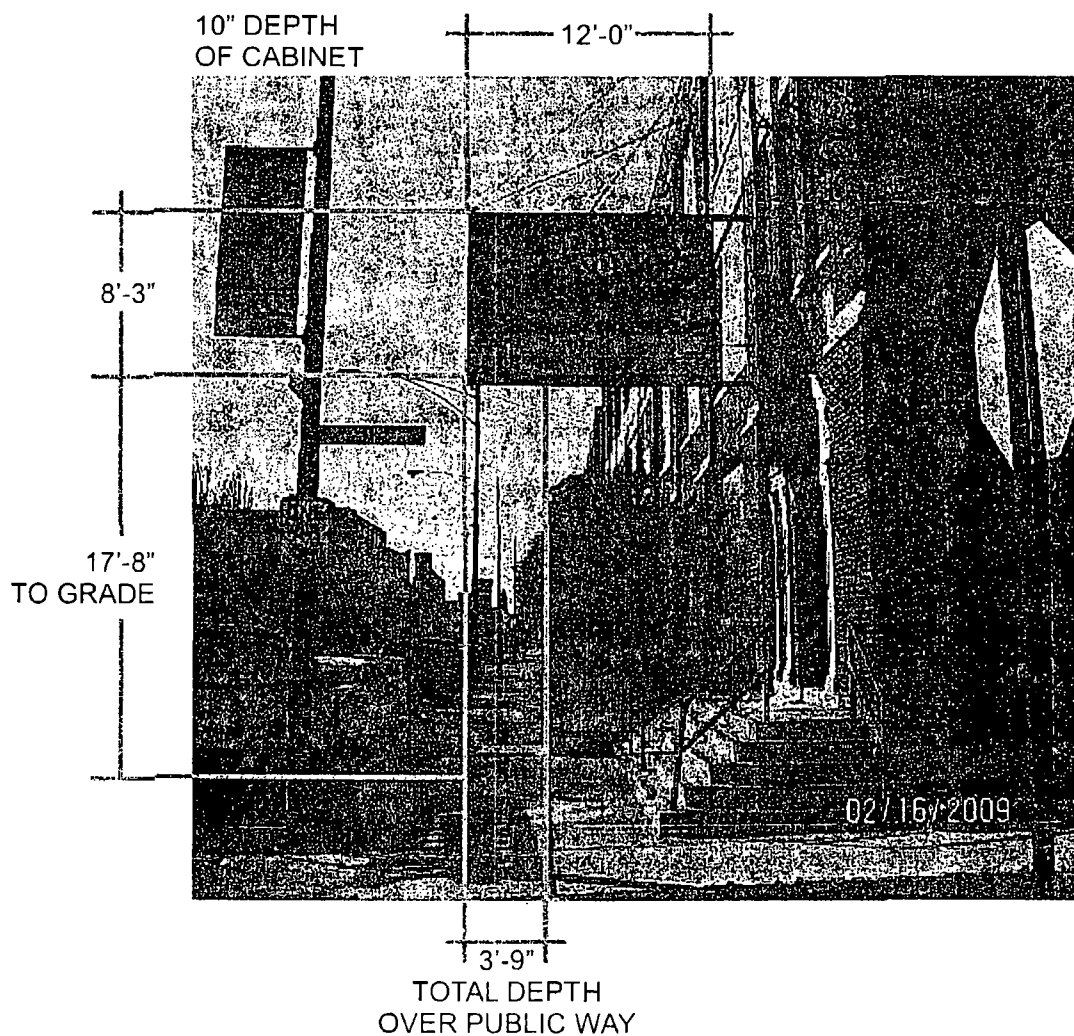



05/28/2014

Alderman Ameya Pawar
Ward # **47**
City of Chicago
City Hall, Room **300**
121 North LaSalle Street
Chicago, Illinois 60602

Re: An ordinance to use and maintain a portion of the public right-of-way for **two (2) sign(s)** for **STRONGBOX**, adjacent to the premises known as **1650 W. Irving Park Rd.**

Dear Alderman **Ameya Pawar**:

The applicant referenced above has requested the use of the public right-of-way for a **sign(s)**. An ordinance has been prepared by the Department of Business Affairs and Consumer Protection – Small Business Center - Public Way Use Unit for presentation to the City Council. Because this request was made for properties located in your ward, as approved by you as per the attached, I respectfully request that you introduce the attached ordinance at the next City Council meeting.

If you have any questions regarding this ordinance, please contact Anthony Bertuca at (312) 744-5506.

Department of Business Affairs and Consumer Protection



City of Chicago



O2014-4775

Office of the City Clerk

Document Tracking Sheet

| | |
|---------------------------------|--|
| Meeting Date: | 5/28/2014 |
| Sponsor(s): | Pawar (47) |
| Type: | Ordinance |
| Title: | Grant(s) of privilege in public way for Thai Oscar |
| Committee(s) Assignment: | Committee on Transportation and Public Way |

ORDINANCE
THAI OSCAR
Acct. No. 323729 - 1
Permit No. 1112848

Be It Ordained by the City Council of the City of Chicago:

SECTION 1. Permission and authority are hereby given and granted to THAI OSCAR, upon the terms and subject to the conditions of this ordinance to maintain and use one (1) sign(s) projecting over the public right-of-way attached to its premises known as 4638 N. Western Ave..

Said sign structure(s) measures as follows; along N. Western Avenue:

One (1) at two point five (2.5) feet in length, two point five (2.5) feet in height and eleven (11) feet above grade level.

The location of said privilege shall be as shown on prints kept on file with the Department of Business Affairs and Consumer Protection and the Office of the City Clerk.

Said privilege shall be constructed in accordance with plans and specifications approved by the Department of Transportation (Division of Project Development) and Zoning Department - Signs.

This grant of privilege in the public way shall be subject to the provisions of Section 10-28-015 and all other required provisions of the Municipal Code of Chicago.

The grantee shall pay to the City of Chicago as compensation for the privilege #1112848 herein granted the sum of one hundred (\$100.00) per annum in advance.

A 25% penalty will be added for payments received after due date.

The permit holder agrees to hold the City of Chicago harmless for any damage, relocation or replacement costs associated with damage, relocation or removal of private property caused by the City performing work in the public way.

Authority herein given and granted for a period of five (5) years from and after 01/13/2014.

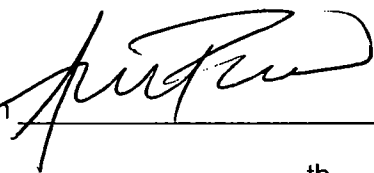
Alderman 
Ameya Pawar 47th Ward

323729 DREV

1/15/2014 Date

1082314 Permit #

That Oscar Restaurant
4638 N. Western Ave
Chicago IL 60625

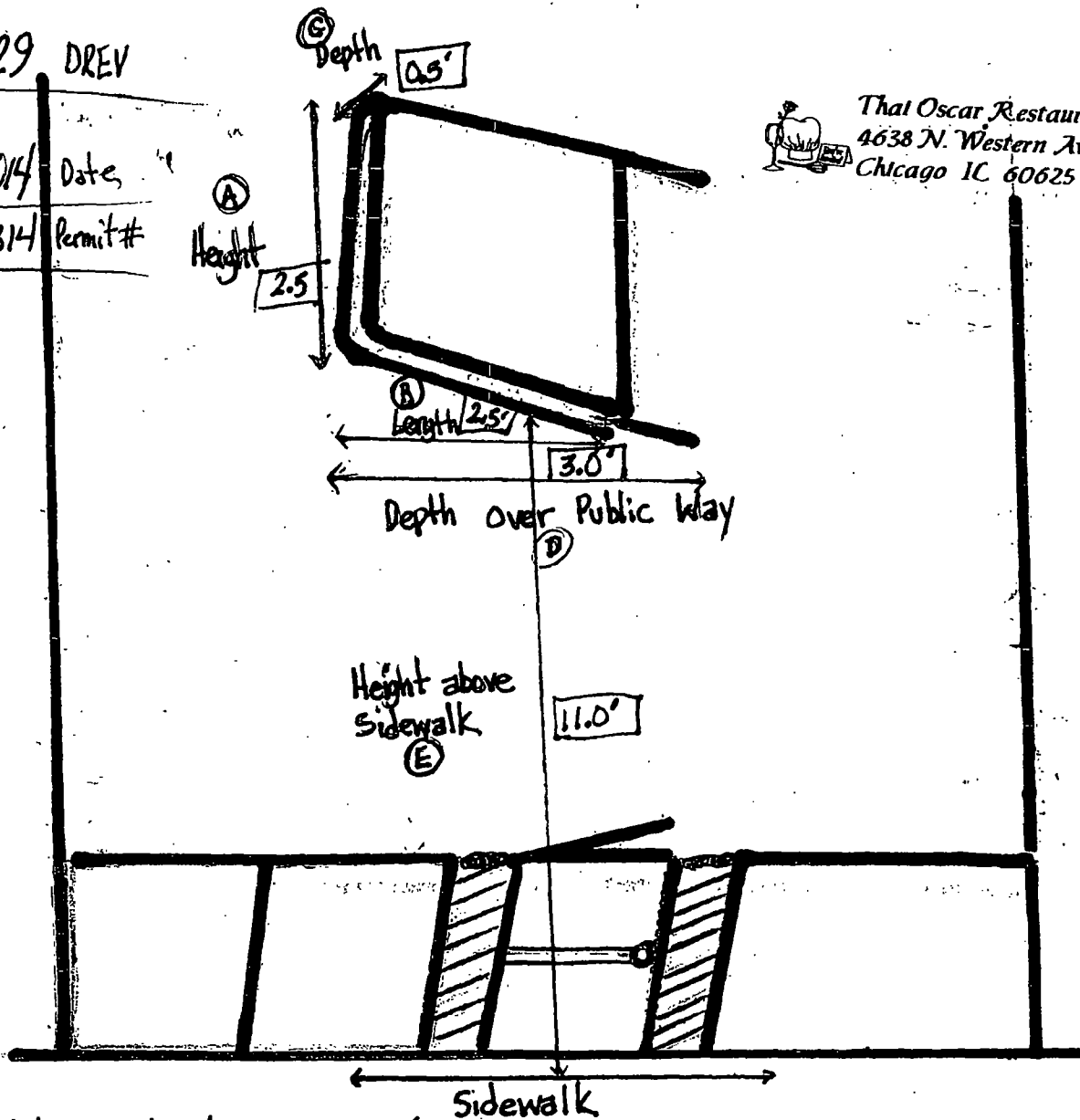

- (A) Height of Structure 2.5'
- (B) Length of Structure 2.5'
- (C) Depth of Structure 0.5'
- (D) Total Depth over public way 3.0'
- (E) Height above sidewalk 11.0'

Western Avenue



05/28/2014

Alderman Ameya Pawar
Ward # **47**
City of Chicago
City Hall, Room **300**
121 North LaSalle Street
Chicago, Illinois 60602

Re: An ordinance to use and maintain a portion of the public right-of-way for **one (1) sign(s)** for **THAI OSCAR**, adjacent to the premises known as **4638 N. Western Ave.**.

Dear Alderman **Ameya Pawar**:

The applicant referenced above has requested the use of the public right-of-way for a **sign(s)**. An ordinance has been prepared by the Department of Business Affairs and Consumer Protection – Small Business Center - Public Way Use Unit for presentation to the City Council. Because this request was made for properties located in your ward, as approved by you as per the attached, I respectfully request that you introduce the attached ordinance at the next City Council meeting.

If you have any questions regarding this ordinance, please contact Anthony Bertuca at (312) 744-5506.

Department of Business Affairs and Consumer Protection



City of Chicago



O2014-4777

Office of the City Clerk

Document Tracking Sheet

| | |
|---------------------------------|--|
| Meeting Date: | 5/28/2014 |
| Sponsor(s): | Osterman (48) |
| Type: | Ordinance |
| Title: | Grant(s) of privilege in public way for Bryn Mawr Belle Shore L.P. |
| Committee(s) Assignment: | Committee on Transportation and Public Way |

ORDINANCE
BRYN MAWR BELLE SHORE LMTD. PARTNERSHIP
Acct. No. 88243 - 1
Permit No. 1112874

Be It Ordained by the City Council of the City of Chicago:

SECTION 1. Permission and authority are hereby given and granted to BRYN MAWR BELLE SHORE LMTD. PARTNERSHIP, upon the terms and subject to the conditions of this ordinance to maintain and use, as now constructed, one (1) Grease Trap(s) under the public right-of-way adjacent to its premises known as 1062 W. Bryn Mawr Ave..

Said Grease Trap(s) at W. BRYN MAWR AVE. measure(s):
One (1) at ten (10) feet in length, and five (5) feet in width for a total of fifty (50) square feet.

The location of said privilege shall be as shown on prints kept on file with the Department of Business Affairs and Consumer Protection and the Office of the City Clerk.

Said privilege shall be constructed in accordance with plans and specifications approved by the Department of Transportation (Office of Underground Coordination) and Department of Water Management.

This grant of privilege in the public way shall be subject to the provisions of Section 10-28-015 and all other required provisions of the Municipal Code of Chicago.

The grantee shall pay to the City of Chicago as compensation for the privilege #1112874 herein granted the sum of four hundred (\$400.00) per annum in advance.

A 25% penalty will be added for payments received after due date.

The permit holder agrees to hold the City of Chicago harmless for any damage, relocation or replacement costs associated with damage, relocation or removal of private property caused by the City performing work in the public way.

Authority herein given and granted for a period of five (5) years from and after 11/20/2006.

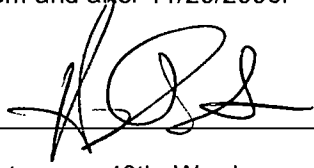
Alderman  _____
Harry Osterman 48th Ward



05/28/2014

Alderman **Harry Osterman**
Ward # 48
City of Chicago
City Hall, Room 300
121 North LaSalle Street
Chicago, Illinois 60602

Re: An ordinance to use and maintain a portion of the public right-of-way for **one (1) grease trap(s)** for **BRYN MAWR BELLE SHORE LMTD. PARTNERSHIP**, adjacent to the premises known as **1062 W. Bryn Mawr Ave.**

Dear Alderman **Harry Osterman**:

The applicant referenced above has requested the use of the public right-of-way for a **grease trap(s)**. An ordinance has been prepared by the Department of Business Affairs and Consumer Protection – Small Business Center - Public Way Use Unit for presentation to the City Council. Because this request was made for properties located in your ward, as approved by you as per the attached, I respectfully request that you introduce the attached ordinance at the next City Council meeting.

If you have any questions regarding this ordinance, please contact Anthony Bertuca at (312) 744-5506.

Department of Business Affairs and Consumer Protection



City of Chicago



O2014-4779

Office of the City Clerk

Document Tracking Sheet

| | |
|---------------------------------|--|
| Meeting Date: | 5/28/2014 |
| Sponsor(s): | Osterman (48) |
| Type: | Ordinance |
| Title: | Grant(s) of privilege in public way for Bryn Mawr Sheridan |
| Committee(s) Assignment: | Committee on Transportation and Public Way |

ORDINANCE
BRYN MAWR SHERIDAN
Acct. No. 274023 - 1
Permit No. 1112270

Be It Ordained by the City Council of the City of Chicago:

SECTION 1. Permission and authority are hereby given and granted to BRYN MAWR SHERIDAN, upon the terms and subject to the conditions of this ordinance to maintain and use, as now constructed, six (6) Roof Eave(s) projecting over the public right-of-way adjacent to its premises known as 5556 N. Sheridan Rd..

Said Roof Eave(s) at W. Bryn Mawr measure(s):

One (1) at nineteen (19) feet in length, and one point three three (1.33) foot in width for a total of twenty-five point two seven (25.27) square feet. Existing roof eave is approximately sixty-six (66) feet above grade level.

One (1) at thirty-nine point two five (39.25) feet in length, and one point three three (1.33) foot in width for a total of fifty-two point two (52.2) square feet. Existing roof eave is approximately sixty-six (66) Feet above grade level.

One (1) at eighteen point four one (18.41) feet in length, and one point zero eight (1.08) foot in width for a total of nineteen point eight eight (19.88) square feet. Existing roof eave is approximately sixty-six (66) feet above grade level.

Said Roof Eave(s) at N. Sheridan Rd measure(s):

One (1) at twelve point seven five (12.75) feet in length, and one point five (1.5) foot in width for a total of nineteen point one three (19.13) square feet. Existing roof eave is approximately sixty-six (66) feet above grade level.

One (1) at eighteen (18) feet in length, and one (1) foot in width for a total of eighteen (18) square feet. Existing roof eave is approximately sixty-six (66) feet above grade level.

One (1) at thirty-nine point two five (39.25) feet in length, and one (1) foot in width for a total of thirty-nine point two five (39.25) square feet. Existing roof eave is approximately sixty-six (66) feet above grade level.

The location of said privilege shall be as shown on prints kept on file with the Department of Business Affairs and Consumer Protection and the Office of the City Clerk.

Said privilege shall be constructed in accordance with plans and specifications approved by the Department of Transportation (Division of Project Development).

This grant of privilege in the public way shall be subject to the provisions of Section 10-28-015 and all other required provisions of the Municipal Code of Chicago.

The grantee shall pay to the City of Chicago as compensation for the privilege #1112270 herein granted the sum of two thousand four hundred (\$2,400.00) per annum in advance.

A 25% penalty will be added for payments received after due date.

The permit holder agrees to hold the City of Chicago harmless for any damage, relocation or replacement costs associated with damage, relocation or removal of private property caused by the City performing work in the public way.

Authority herein given and granted for a period of five (5) years from and after 03/31/2014.

Alderman _____

Harry Osterman 48th Ward

WEST BRYN MAWR AVENUE

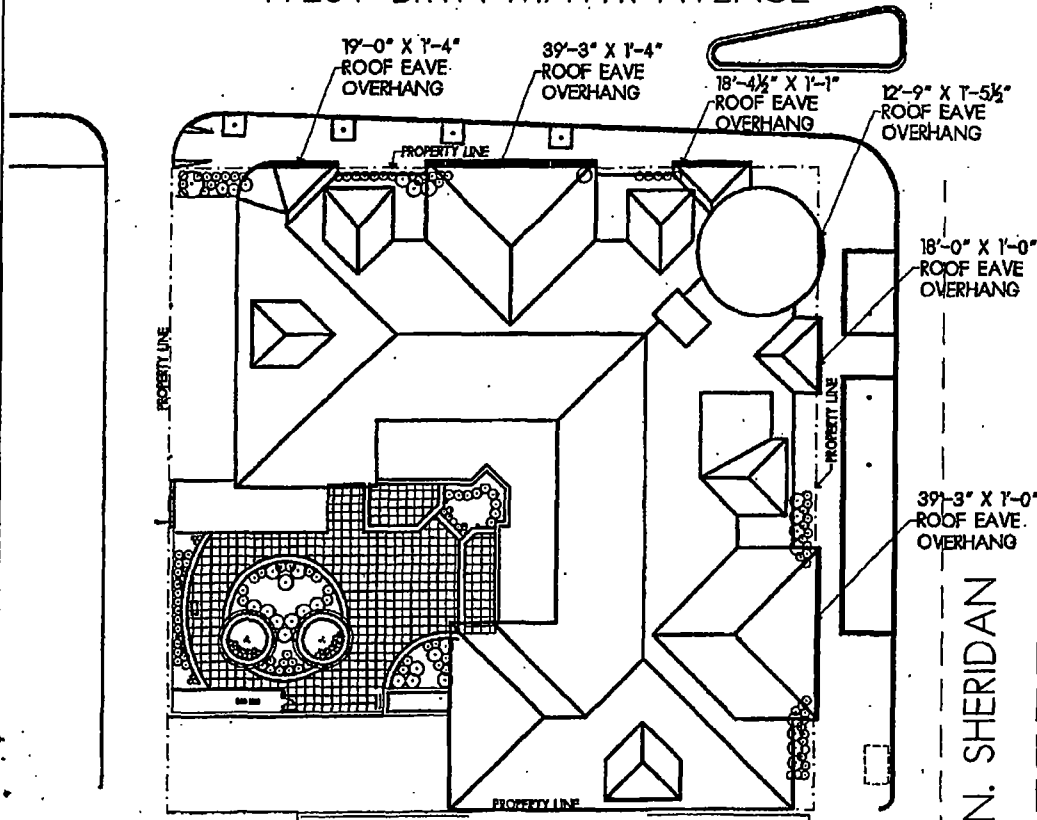

NOV. 3, 2003

THE ATELIER
BRYN MAWR & SHERIDAN CONDOMINIUMS
6556 N. SHERIDAN ROAD CHICAGO, ILLINOIS

ROOF EAVE OVERHANG ABOVE THE PUBLIC WAY

N. SHERIDAN



05/28/2014

Alderman Harry Osterman
Ward # 48
City of Chicago
City Hall, Room 300
121 North LaSalle Street
Chicago, Illinois 60602

Re: An ordinance to use and maintain a portion of the public right-of-way for **six (6) roof eave(s)** for **BRYN MAWR SHERIDAN**, adjacent to the premises known as **5556 N. Sheridan Rd.**

Dear Alderman **Harry Osterman**:

The applicant referenced above has requested the use of the public right-of-way for **roof eave(s)**. An ordinance has been prepared by the Department of Business Affairs and Consumer Protection – Small Business Center - Public Way Use Unit for presentation to the City Council. Because this request was made for properties located in your ward, as approved by you as per the attached, I respectfully request that you introduce the attached ordinance at the next City Council meeting.

If you have any questions regarding this ordinance, please contact Anthony Bertuca at (312) 744-5506.

Department of Business Affairs and Consumer Protection



City of Chicago



O2014-4780

Office of the City Clerk

Document Tracking Sheet

| | |
|---------------------------------|--|
| Meeting Date: | 5/28/2014 |
| Sponsor(s): | Osterman (48) |
| Type: | Ordinance |
| Title: | Grant(s) of privilege in public way for Indie Cafe |
| Committee(s) Assignment: | Committee on Transportation and Public Way |

ORDINANCE
INDIE CAFE
Acct. No. 283535 - 2
Permit No. 1113156

Be It Ordained by the City Council of the City of Chicago:

SECTION 1. Permission and authority are hereby given and granted to INDIE CAFE, upon the terms and subject to the conditions of this ordinance to construct, install, maintain and use two (2) Light Fixture(s) projecting over the public right-of-way adjacent to its premises known as 5951-53 N. Broadway .

Said Light Fixture(s) at N Broadway St measure(s):

Two (2) at one point five (1.5) foot in length, one point five (1.5) foot in width and ten point eight three (10.83) feet above grade level.

The location of said privilege shall be as shown on prints kept on file with the Department of Business Affairs and Consumer Protection and the Office of the City Clerk.

Said privilege shall be constructed in accordance with plans and specifications approved by the Department of Transportation (Division of Project Development).

This grant of privilege in the public way shall be subject to the provisions of Section 10-28-015 and all other required provisions of the Municipal Code of Chicago.

The grantee shall pay to the City of Chicago as compensation for the privilege #1113156 herein granted the sum of eighty (\$80.00) per annum in advance.

A 25% penalty will be added for payments received after due date.

The permit holder agrees to hold the City of Chicago harmless for any damage, relocation or replacement costs associated with damage, relocation or removal of private property caused by the City performing work in the public way.

Authority herein given and granted for a period of five (5) years from and after Date of Passage.

Alderman _____

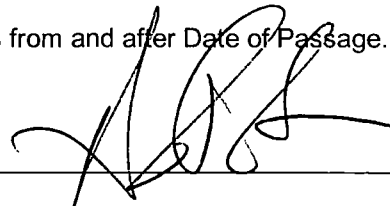

Harry Osterman 48th Ward



4 EXISTING VIEW FROM WEST
From SITE

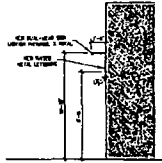

3 LIGHTING / SIGN SECTION
From SITE

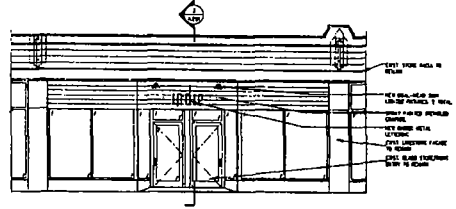

2 WEST ELEVATION
From SITE

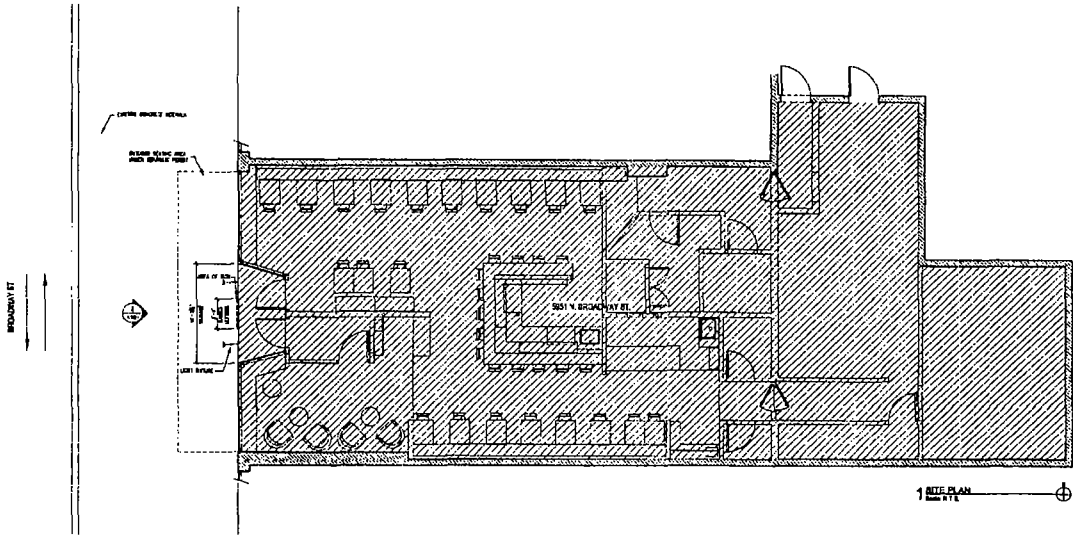

1 SITE PLAN
From SITE

| |
|--|
| STUDIO MENDO |
| ARCHITECTURE |
| 5501 N. BRUNSWAY ST CHICAGO, IL 60640 |
| INDIE CAFE |
| 5501 N. BRUNSWAY ST CHICAGO, IL 60640 |
| PUBLIC REVIEW |
| DATE: 10/15/11 |
| SCALE: 1/8" = 1'-0" |
| PROJECT NO: 11-001 |

A101



05/28/2014

Alderman **Harry Osterman**
Ward # **48**
City of Chicago
City Hall, Room **300**
121 North LaSalle Street
Chicago, Illinois 60602

Re: An ordinance to use and maintain a portion of the public right-of-way for **two (2) light fixture(s)** for **INDIE CAFE**, adjacent to the premises known as **5951-53 N. Broadway**.

Dear Alderman **Harry Osterman**:

The applicant referenced above has requested the use of the public right-of-way for a **light fixture(s)**. An ordinance has been prepared by the Department of Business Affairs and Consumer Protection – Small Business Center - Public Way Use Unit for presentation to the City Council. Because this request was made for properties located in your ward, as approved by you as per the attached, I respectfully request that you introduce the attached ordinance at the next City Council meeting.

If you have any questions regarding this ordinance, please contact Anthony Bertuca at (312) 744-5506.

Department of Business Affairs and Consumer Protection



City of Chicago



O2014-4782

Office of the City Clerk

Document Tracking Sheet

| | |
|---------------------------------|--|
| Meeting Date: | 5/28/2014 |
| Sponsor(s): | Osterman (48) |
| Type: | Ordinance |
| Title: | Grant(s) of privilege in public way for Mariano's No. 8522 |
| Committee(s) Assignment: | Committee on Transportation and Public Way |

ORDINANCE
MARIANO'S #8522
Acct. No. 360006 - 8
Permit No. 1111012

Be It Ordained by the City Council of the City of Chicago:

SECTION 1. Permission and authority are hereby given and granted to MARIANO'S #8522, upon the terms and subject to the conditions of this ordinance to maintain and use four (4) sign(s) projecting over the public right-of-way attached to its premises known as 5201 N. Sheridan Rd..

Said sign structure(s) measures as follows; along N. Sheridan Road:

Two (2) at fifteen (15) feet in length, six point five eight (6.58) feet in height and twenty-five (25) feet above grade level.

Said sign structure(s) measures as follows; along W. Foster Avenue:

One (1) at fifteen (15) feet in length, six point five eight (6.58) feet in height and twenty-five (25) feet above grade level.

Said sign structure(s) measures as follows; along N. Sheridan Road:

One (1) at fifteen (15) feet in length, one point two five (1.25) feet in height and twenty (20) feet above grade level.

The location of said privilege shall be as shown on prints kept on file with the Department of Business Affairs and Consumer Protection and the Office of the City Clerk.

Said privilege shall be constructed in accordance with plans and specifications approved by the Department of Transportation (Division of Project Development) and Zoning Department - Signs.

This grant of privilege in the public way shall be subject to the provisions of Section 10-28-015 and all other required provisions of the Municipal Code of Chicago.

The grantee shall pay to the City of Chicago as compensation for the privilege #1111012 herein granted the sum of one thousand (\$1,000.00) per annum in advance.

A 25% penalty will be added for payments received after due date.

The permit holder agrees to hold the City of Chicago harmless for any damage, relocation or replacement costs associated with damage, relocation or removal of private property caused by the City performing work in the public way.

Authority herein given and granted for a period of five (5) years from and after Date of Passage.

Alderman _____

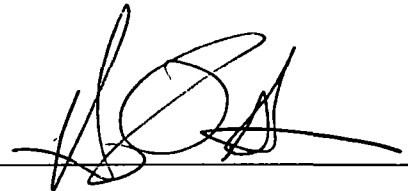

Harry Osterman 48th Ward

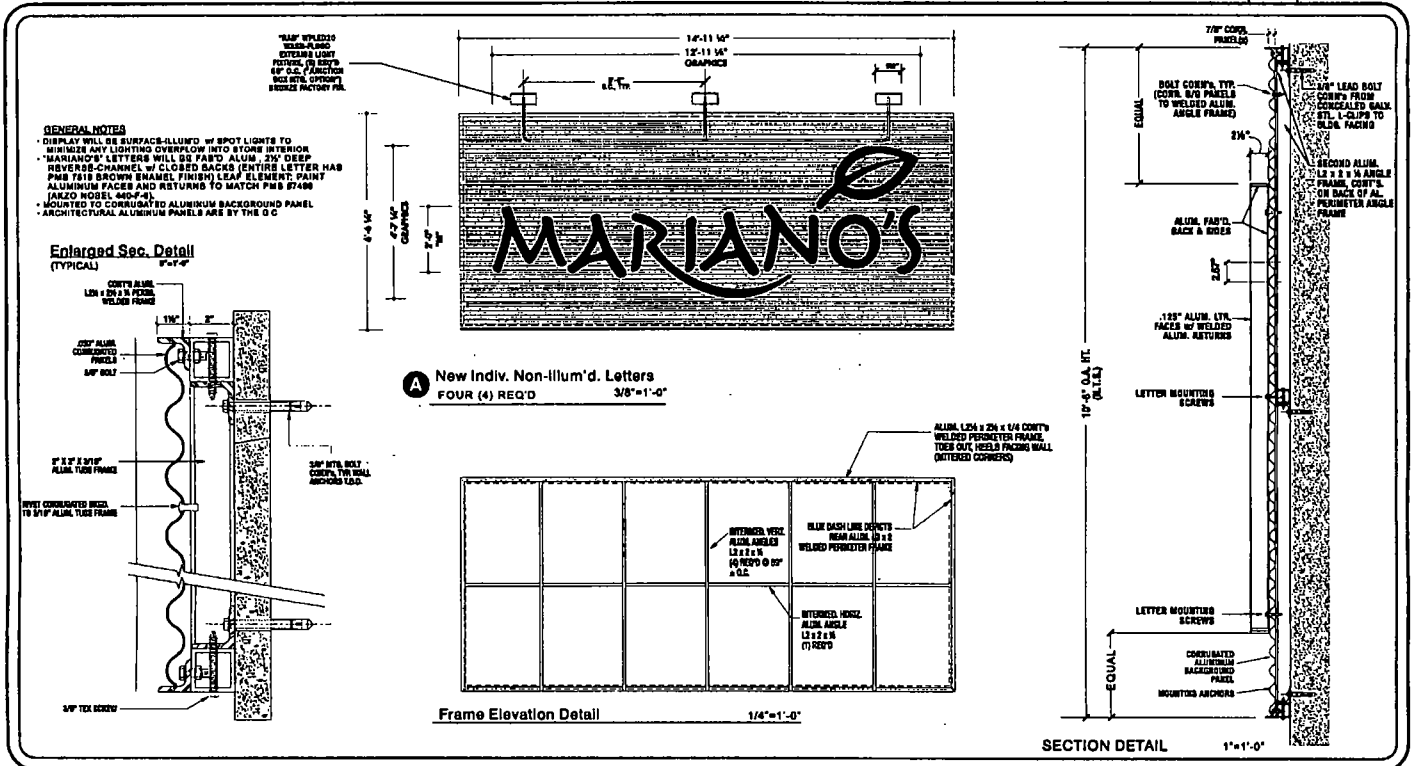

| DATE | REVISION |
|------|----------|
| | |
| | |
| | |

CUSTOMER APPROVAL **DATE**

This design is the original and unpublished work of DOYLE SIGNS, INC. and may not be reproduced, copied or embodied in any fashion without the expressed written consent from an authorized officer of The Company. The rights in this design may be purchased.

CLIENT MARIANO'S FRESH MARKET
ADDRESS 2201 N. SHEDDEN ROAD
CITY CHICAGO **STATE** IL **DESIGNER AT** **SALESPERSON** TD
ENTRVL. NO. 13784 **SCALE** NOTED **DATE** 12.13.13 **SHEET NO.** 2 of 8



05/28/2014

Alderman **Harry Osterman**
Ward # **48**
City of Chicago
City Hall, Room **300**
121 North LaSalle Street
Chicago, Illinois 60602

Re: An ordinance to use and maintain a portion of the public right-of-way for **four (4) sign(s)** for **MARIANO'S #8522**, adjacent to the premises known as **5201 N. Sheridan Rd.**

Dear Alderman **Harry Osterman**:

The applicant referenced above has requested the use of the public right-of-way for a **sign(s)**. An ordinance has been prepared by the Department of Business Affairs and Consumer Protection – Small Business Center - Public Way Use Unit for presentation to the City Council. Because this request was made for properties located in your ward, as approved by you as per the attached, I respectfully request that you introduce the attached ordinance at the next City Council meeting.

If you have any questions regarding this ordinance, please contact Anthony Bertuca at (312) 744-5506.

Department of Business Affairs and Consumer Protection



City of Chicago



O2014-4755

Office of the City Clerk

Document Tracking Sheet

| | |
|---------------------------------|--|
| Meeting Date: | 5/28/2014 |
| Sponsor(s): | Moore (49) |
| Type: | Ordinance |
| Title: | Grant(s) of privilege in public way for Morland Coin Laundry |
| Committee(s) Assignment: | Committee on Transportation and Public Way |

ORDINANCE
MORLAND COIN LAUNDRY
Acct. No. 271461 - 1
Permit No. 1103722

Be It Ordained by the City Council of the City of Chicago:

SECTION 1. Permission and authority are hereby given and granted to MORLAND COIN LAUNDRY, upon the terms and subject to the conditions of this ordinance to maintain and use one (1) sign(s) projecting over the public right-of-way attached to its premises known as 1522 W. Morse Ave..

Said sign structure(s) measures as follows; along W Morse Ave:
One (1) at twenty-three (23) feet in length, two (2) feet in height and fourteen (14) feet above grade level.

The location of said privilege shall be as shown on prints kept on file with the Department of Business Affairs and Consumer Protection and the Office of the City Clerk.

Said privilege shall be constructed in accordance with plans and specifications approved by the Department of Transportation (Division of Project Development) and Zoning Department - Signs.

This grant of privilege in the public way shall be subject to the provisions of Section 10-28-015 and all other required provisions of the Municipal Code of Chicago.

The grantee shall pay to the City of Chicago as compensation for the privilege #1103722 herein granted the sum of three hundred (\$300.00) per annum in advance.

A 25% penalty will be added for payments received after due date.

The permit holder agrees to hold the City of Chicago harmless for any damage, relocation or replacement costs associated with damage, relocation or removal of private property caused by the City performing work in the public way.

Authority herein given and granted for a period of five (5) years from and after Date of Passage.

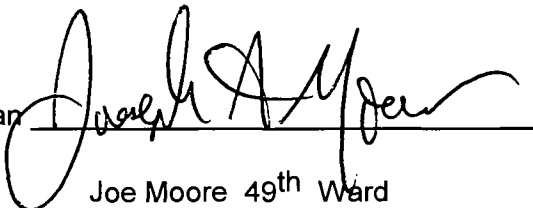
Alderman 
Joe Moore 49th Ward



2nd ATTEMPT AT INTRODUCTION

05/28/2014

Alderman **Joe Moore**
Ward # **49**
City of Chicago
City Hall, Room **300**
121 North LaSalle Street
Chicago, Illinois 60602

Re: An ordinance to use and maintain a portion of the public right-of-way for **one (1) sign(s)** for **MORLAND COIN LAUNDRY**, adjacent to the premises known as **1522 W. Morse Ave.**.

Dear Alderman **Joe Moore**:

The applicant referenced above has requested the use of the public right-of-way for a **sign(s)**. An ordinance has been prepared by the Department of Business Affairs and Consumer Protection – Small Business Center - Public Way Use Unit for presentation to the City Council. Because this request was made for properties located in your ward, as approved by you as per the attached, I respectfully request that you introduce the attached ordinance at the next City Council meeting.

If you have any questions regarding this ordinance, please contact Anthony Bertuca at (312) 744-5506.

Department of Business Affairs and Consumer Protection



City of Chicago



O2014-4757

Office of the City Clerk

Document Tracking Sheet

| | |
|---------------------------------|---|
| Meeting Date: | 5/28/2014 |
| Sponsor(s): | Silverstein (50) |
| Type: | Ordinance |
| Title: | Grant(s) of privilege in public way for Autozone No. 5247 |
| Committee(s) Assignment: | Committee on Transportation and Public Way |

ORDINANCE
AUTOZONE # 5247
Acct. No. 280502 - 21
Permit No. 1113106

Be It Ordained by the City Council of the City of Chicago:

SECTION 1. Permission and authority are hereby given and granted to AUTOZONE # 5247, upon the terms and subject to the conditions of this ordinance to maintain and use two (2) sign(s) projecting over the public right-of-way attached to its premises known as 2555 W. Touhy Ave..

Said sign structure(s) measures as follows; along W TOUHY AVE:

One (1) at eighteen (18) feet in length, four (4) feet in height and twenty-four (24) feet above grade level.

One (1) at thirty-three (33) feet in length, two point five (2.5) feet in height and eighteen (18) feet above grade level.

The location of said privilege shall be as shown on prints kept on file with the Department of Business Affairs and Consumer Protection and the Office of the City Clerk.

Said privilege shall be constructed in accordance with plans and specifications approved by the Department of Transportation (Division of Project Development) and Zoning Department - Signs.

This grant of privilege in the public way shall be subject to the provisions of Section 10-28-015 and all other required provisions of the Municipal Code of Chicago.

The grantee shall pay to the City of Chicago as compensation for the privilege #1113106 herein granted the sum of six hundred (\$600.00) per annum in advance.

A 25% penalty will be added for payments received after due date.

The permit holder agrees to hold the City of Chicago harmless for any damage, relocation or replacement costs associated with damage, relocation or removal of private property caused by the City performing work in the public way.

Authority herein given and granted for a period of five (5) years from and after 04/22/2014.

Alderman 
Debra L. Silverstein 50th Ward

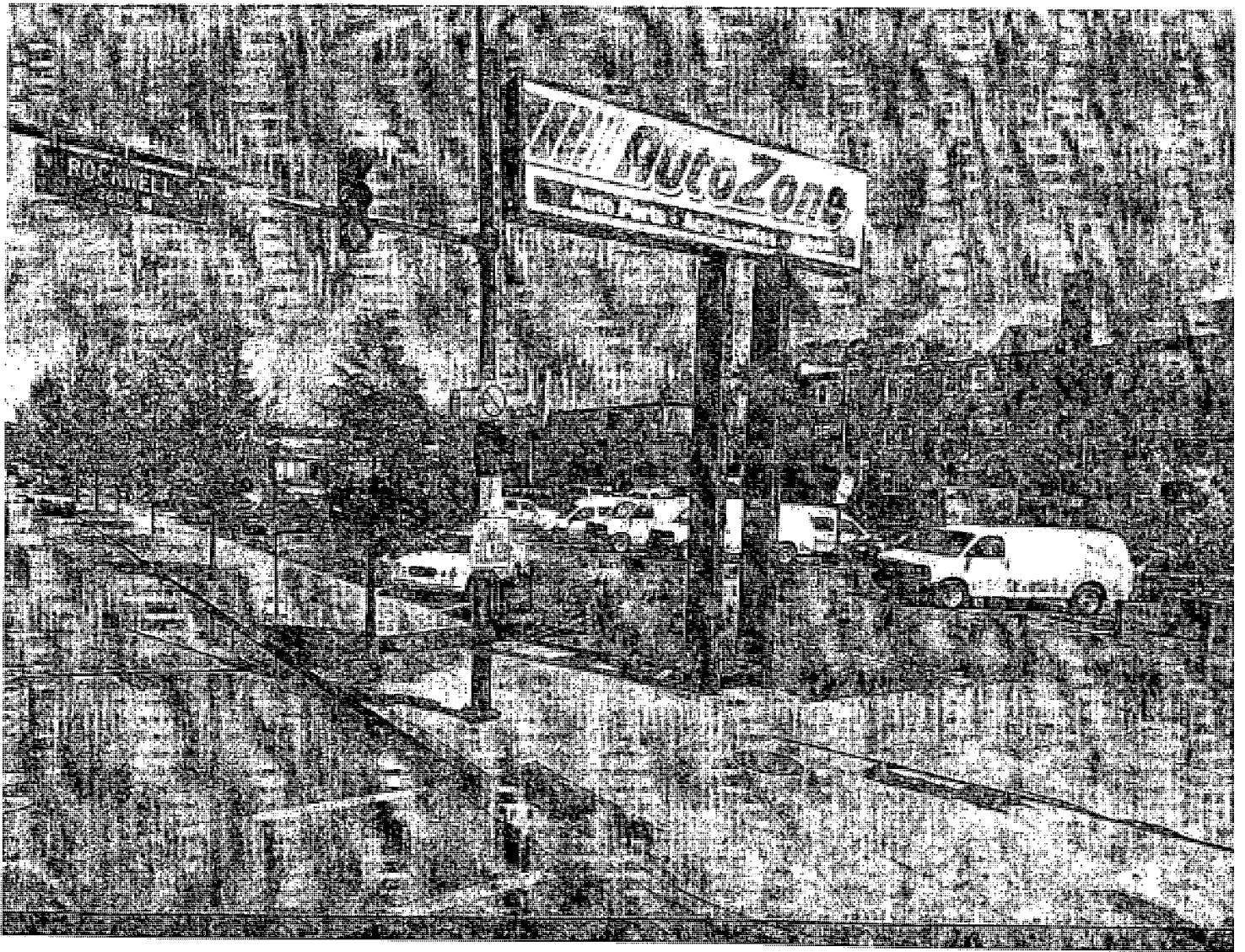



City of Chicago



O2014-4760

Office of the City Clerk

Document Tracking Sheet

| | |
|---------------------------------|--|
| Meeting Date: | 5/28/2014 |
| Sponsor(s): | Silverstein (50) |
| Type: | Ordinance |
| Title: | Grant(s) of privilege in public way for K.R.K. International Corporation |
| Committee(s) Assignment: | Committee on Transportation and Public Way |

ORDINANCE
K.R.K. INTERNATIONAL CORPORATION
Acct. No. 212634 - 4
Permit No. 1110834

Be It Ordained by the City Council of the City of Chicago:

SECTION 1. Permission and authority are hereby given and granted to K.R.K. INTERNATIONAL CORPORATION, upon the terms and subject to the conditions of this ordinance to maintain and use one (1) sign(s) projecting over the public right-of-way attached to its premises known as 6401 N. Campbell Ave..

Said sign structure(s) measures as follows; along N. Campbell:
One (1) at five (5) feet in length, six (6) feet in height and twelve (12) feet above grade level.

The location of said privilege shall be as shown on prints kept on file with the Department of Business Affairs and Consumer Protection and the Office of the City Clerk.

Said privilege shall be constructed in accordance with plans and specifications approved by the Department of Transportation (Division of Project Development) and Zoning Department - Signs.

This grant of privilege in the public way shall be subject to the provisions of Section 10-28-015 and all other required provisions of the Municipal Code of Chicago.

The grantee shall pay to the City of Chicago as compensation for the privilege #1110834 herein granted the sum of three hundred (\$300.00) per annum in advance.

A 25% penalty will be added for payments received after due date.

The permit holder agrees to hold the City of Chicago harmless for any damage, relocation or replacement costs associated with damage, relocation or removal of private property caused by the City performing work in the public way.

Authority herein given and granted for a period of five (5) years from and after 01/13/2014.

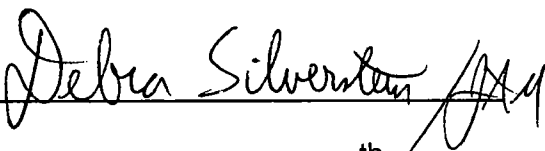
Alderman 
Debra L. Silverstein 50th Ward

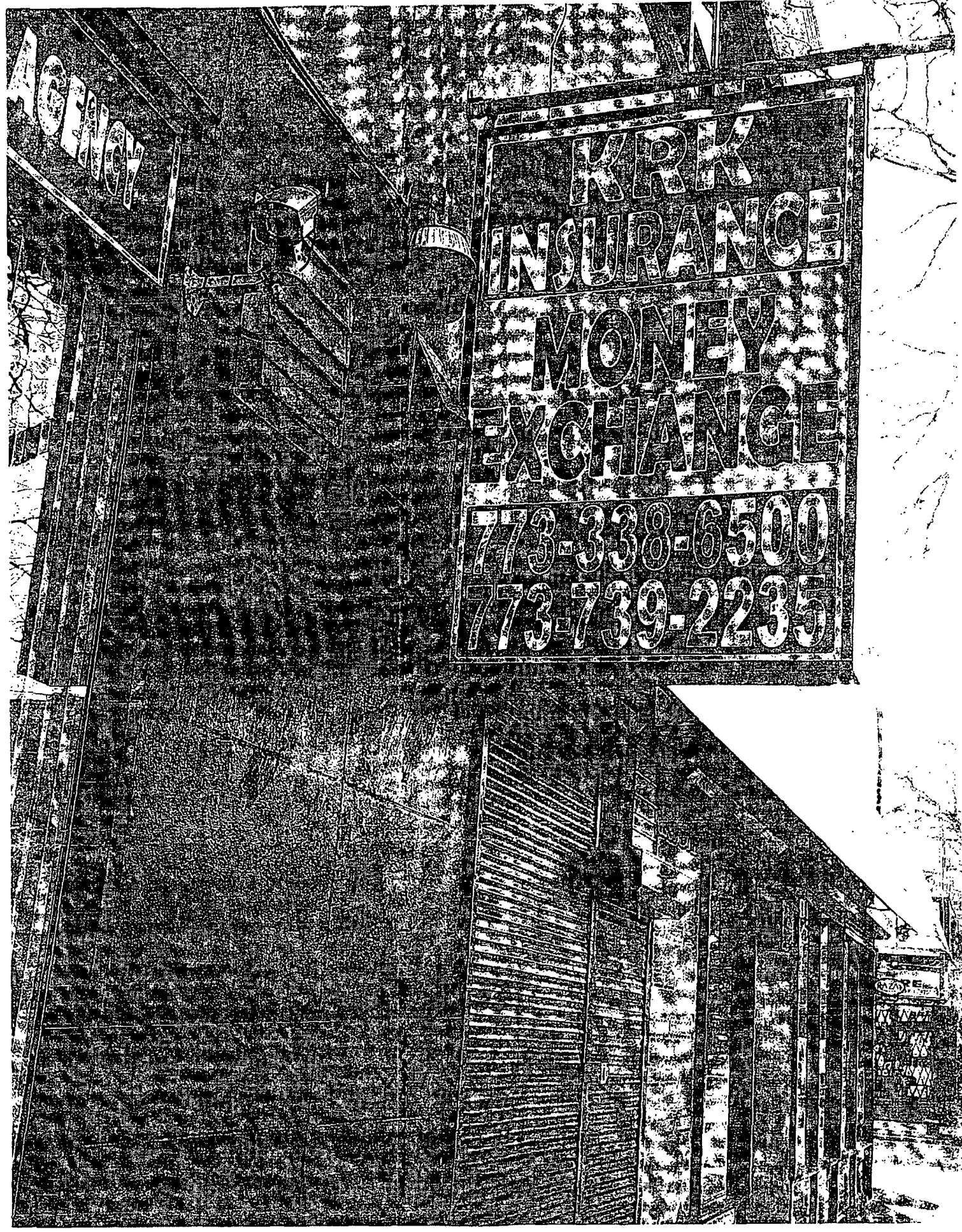

AGENCY

KRK
INSURANCE

MONEY
EXCHANGE

773-338-6500

773-739-2235



City of Chicago



O2014-4762

Office of the City Clerk

Document Tracking Sheet

| | |
|---------------------------------|---|
| Meeting Date: | 5/28/2014 |
| Sponsor(s): | Silverstein (50) |
| Type: | Ordinance |
| Title: | Grant(s) of privilege in public way for New Devon Video |
| Committee(s) Assignment: | Committee on Transportation and Public Way |

ORDINANCE
NEW DEVON VIDEO
Acct. No. 329675 - 1
Permit No. 1111894

Be It Ordained by the City Council of the City of Chicago:

SECTION 1. Permission and authority are hereby given and granted to NEW DEVON VIDEO, upon the terms and subject to the conditions of this ordinance to maintain and use one (1) sign(s) projecting over the public right-of-way attached to its premises known as 6405 N. Oakley Ave..

Said sign structure(s) measures as follows; along N. Oakley Avenue:
One (1) at four (4) feet in length, four (4) feet in height and twelve (12) feet above grade level.

The location of said privilege shall be as shown on prints kept on file with the Department of Business Affairs and Consumer Protection and the Office of the City Clerk.

Said privilege shall be constructed in accordance with plans and specifications approved by the Department of Transportation (Division of Project Development) and Zoning Department - Signs.

This grant of privilege in the public way shall be subject to the provisions of Section 10-28-015 and all other required provisions of the Municipal Code of Chicago.

The grantee shall pay to the City of Chicago as compensation for the privilege #1111894 herein granted the sum of one hundred (\$100.00) per annum in advance.

A 25% penalty will be added for payments received after due date.

The permit holder agrees to hold the City of Chicago harmless for any damage, relocation or replacement costs associated with damage, relocation or removal of private property caused by the City performing work in the public way.

Authority herein given and granted for a period of five (5) years from and after 07/30/2013.

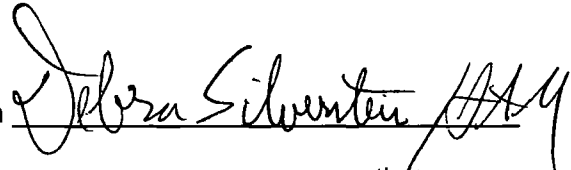
Alderman 
Debra L. Silverstein 50th Ward





City of Chicago



O2014-4763

Office of the City Clerk

Document Tracking Sheet

| | |
|---------------------------------|--|
| Meeting Date: | 5/28/2014 |
| Sponsor(s): | Silverstein (50) |
| Type: | Ordinance |
| Title: | Grant(s) of privilege in public way for Pride Sushi and Thai |
| Committee(s) Assignment: | Committee on Transportation and Public Way |

ORDINANCE
PRIDE SUSHI AND THAI
Acct. No. 388405 - 1
Permit No. 1111274

Be It Ordained by the City Council of the City of Chicago:

SECTION 1. Permission and authority are hereby given and granted to PRIDE SUSHI AND THAI, upon the terms and subject to the conditions of this ordinance to maintain and use one (1) sign(s) projecting over the public right-of-way attached to its premises known as 2706 W. Peterson Ave..

Said sign structure(s) measures as follows; along W. Peterson Avenue:
One (1) at seventeen point four two (17.42) feet in length, four (4) feet in height and nine (9) feet above grade level.

The location of said privilege shall be as shown on prints kept on file with the Department of Business Affairs and Consumer Protection and the Office of the City Clerk.

Said privilege shall be constructed in accordance with plans and specifications approved by the Department of Transportation (Division of Project Development) and Zoning Department - Signs.

This grant of privilege in the public way shall be subject to the provisions of Section 10-28-015 and all other required provisions of the Municipal Code of Chicago.

The grantee shall pay to the City of Chicago as compensation for the privilege #1111274 herein granted the sum of three hundred (\$300.00) per annum in advance.

A 25% penalty will be added for payments received after due date.

The permit holder agrees to hold the City of Chicago harmless for any damage, relocation or replacement costs associated with damage, relocation or removal of private property caused by the City performing work in the public way.

Authority herein given and granted for a period of five (5) years from and after Date of Passage.

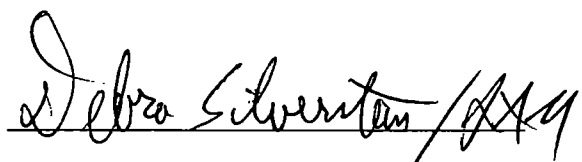
Alderman 
Debra L. Silverstein 50th Ward

Sign 1 ILLUMINTAED METAL LETTER SIGN

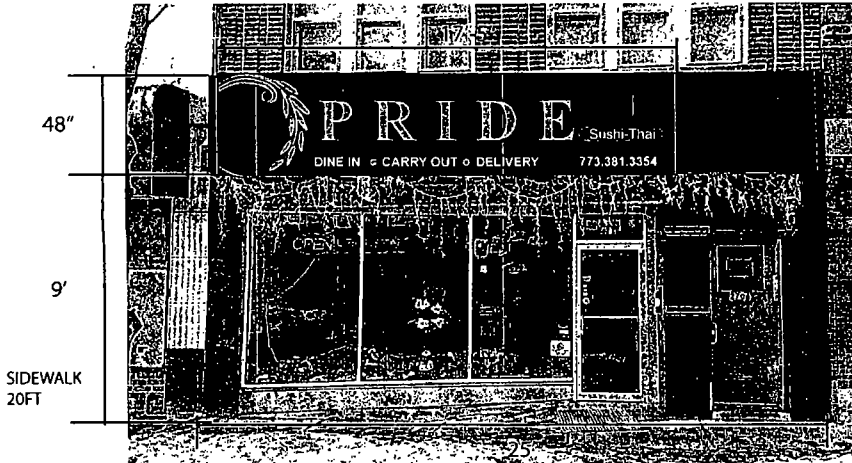

EXITING SIGN



SIDE VIEW



SPECIFICATIONS

QUANTITY: ONE (1)
Overall Height: 4'
Overall Length: 17'-05"
Total Sq.Ft.: 70 ft²
Face/Returns: Brush Aluminum
Illumination: Yellow, Blue & Red LED

NOTES:
 • Individually Mounted

COLOR SCHEDULE

CHANNEL LETTER - TYPICAL SECTION - REVERSE-LIT

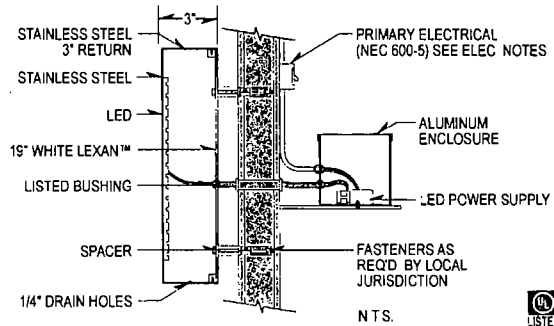

ELECTRICAL NOTES

Sign Company DOES NOT provide primary electrical to sign.
 Power to the sign must be done by a licensed electrical contractor or licensed electrician.
 Each sign must have:

1. A minimum of one dedicated 120V 20A circuit
2. Junction box installed within 6 feet of sign
3. Three wires: Line, Ground, Neutral



(Bridgeway)
 Chicago, IL

3401 S. Halsted St.
 Chicago, IL 60608
 773-847-2828
 Fax 773-847-0088

SIGN ELEVATION EXHIBIT

Address: 2706 W Peterson

City: Chicago, IL

Account Rep: K. WONG

APPROVALS
 CLIENT: _____
 DESIGN: _____
 PROD: _____

Designer: K. WONG

Design No: _____

DATE: 01-03-12

Rev Date: _____

3:4

The purchaser agrees to hold the seller harmless against any cause for action for damage which may occur as a result of drilling for signs and hardware, including but not limited to, signs, cables or any other equipment or materials which the purchaser or others may deem valuable.



City of Chicago



O2014-4476

Office of the City Clerk Document Tracking Sheet

| | |
|---------------------------------|---|
| Meeting Date: | 5/28/2014 |
| Sponsor(s): | Burnett (27) |
| Type: | Ordinance |
| Title: | Amendment of grant(s) of privilege in public way to Belly Q/Urban Belly II |
| Committee(s) Assignment: | Committee on Transportation and Public Way |

ORDINANCE AMENDMENT

Acct. No. 19446 - 1

Permit No. 1111595

BE IT ORDAINED BY THE CITY COUNCIL OF THE CITY OF CHICAGO:

Section 1:

The ordinance passed by the City Council of the City of Chicago for **BELLY Q / URBAN BELLY II** on **04/02/2014**, and printed upon page **77892** of the Journal of Proceedings of the City of Chicago is here by Amended by deleting the words "Hours of Operation: Sunday 3:00 p.m." and inserting in their place the words "Hours of Operation: Sunday 11:00 a.m."

Section 2:

This ordinance Amendment shall be in effect upon its passage.

ALDERMAN:

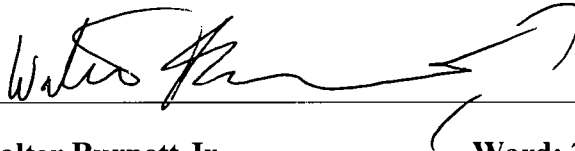

Walter Burnett Jr.

Ward: 27

05-28-14

Date:



City of Chicago



O2014-4304

Office of the City Clerk
Document Tracking Sheet

Meeting Date: 5/28/2014
Sponsor(s): Reilly (42)
Type: Ordinance
Title: Amendment of grant(s) of privilege in public way to NM Project Company LLC - six columns
Committee(s) Assignment: Committee on Transportation and Public Way

ORDINANCE AMENDMENT

Acct. No. 389577 - 1

Permit No. 1094343

BE IT ORDAINED BY THE CITY COUNCIL OF THE CITY OF CHICAGO:

Section 1:

The ordinance passed by the City Council of the City of Chicago for NM PROJECT COMPANY, LLC on 11/02/2011, and printed upon page 12020 of the Journal of Proceedings of the City of Chicago is here by Amended by deleting the words "NM PROJECT COMPANY, LLC" and inserting in their place the words "THE RESIDENCES CONDOMINIUM ON THE MAGNIFICENT MILE CONDOMINIUM ASSOCIATION"

Section 2:

This ordinance Amendment shall be in effect upon its passage.

ALDERMAN: _____

Brendan Reilly

Ward: 42

Date

5. 9



04/30/2014

Alderman **Brendan Reilly**
Ward # **42**
City of Chicago
City Hall, Room **306**
121 North LaSalle Street
Chicago, Illinois 60602

Re: An amended ordinance to use and maintain a portion of the public right-of-way for **six (6) column(s)** for **THE RESIDENCES CONDOMINIUM ON THE MAGNIFICENT MILE CONDOMINIUM ASSOCIATION**, adjacent to the premises known as **118 E. Erie St.**

Dear Alderman **Brendan Reilly**:

The applicant referenced above has requested the use of the public right-of-way for a **column(s)**. An ordinance has been prepared by the Department of Business Affairs and Consumer Protection – Small Business Center - Public Way Use Unit for presentation to the City Council. Because this request was made for properties located in your ward, as approved by you as per the attached, I respectfully request that you introduce the attached ordinance at the next City Council meeting.

If you have any questions regarding this ordinance, please contact Anthony Bertuca at (312) 744-5506.

Department of Business Affairs and Consumer Protection



City of Chicago



O2014-4372

Office of the City Clerk

Document Tracking Sheet

| | |
|---------------------------------|--|
| Meeting Date: | 5/28/2014 |
| Sponsor(s): | Reilly (42) |
| Type: | Ordinance |
| Title: | Amendment of grant(s) of privilege in public way to NM Project Company LLC - four archs |
| Committee(s) Assignment: | Committee on Transportation and Public Way |

ORDINANCE AMENDMENT

Acct. No. 389577 - 1

Permit No. 1094339

BE IT ORDAINED BY THE CITY COUNCIL OF THE CITY OF CHICAGO:

Section 1:

The ordinance passed by the City Council of the City of Chicago for on **11/02/2011**, and printed upon page **12020** of the Journal of Proceedings of the City of Chicago is here by Amended by deleting the words "NM PROJECT COMPANY, LLC" and inserting in their place the words "THE RESIDENCES CONDOMINIUM ON THE MAGNIFICENT MILE CONDOMINIUM ASSOCIATION"

Section 2:

This ordinance Amendment shall be in effect upon its passage.

ALDERMAN: _____



Brendan Reilly

Ward: 42

Date: _____

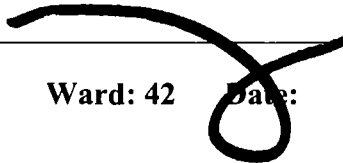

5. 2



04/30/2014

Alderman **Brendan Reilly**
Ward # **42**
City of Chicago
City Hall, Room **306**
121 North LaSalle Street
Chicago, Illinois 60602

Re: An amended ordinance to use and maintain a portion of the public right-of-way for **four (4) arch(s)** for **THE RESIDENCES CONDOMINIUM ON THE MAGNIFICENT MILE CONDOMINIUM ASSOCIATION**, adjacent to the premises known as **118 E. Erie St.**

Dear Alderman **Brendan Reilly**:

The applicant referenced above has requested the use of the public right-of-way for a **arch(s)**. An ordinance has been prepared by the Department of Business Affairs and Consumer Protection – Small Business Center - Public Way Use Unit for presentation to the City Council. Because this request was made for properties located in your ward, as approved by you as per the attached, I respectfully request that you introduce the attached ordinance at the next City Council meeting.

If you have any questions regarding this ordinance, please contact Anthony Bertuca at (312) 744-5506.

Department of Business Affairs and Consumer Protection



City of Chicago



O2014-4381

Office of the City Clerk

Document Tracking Sheet

| | |
|---------------------------------|--|
| Meeting Date: | 5/28/2014 |
| Sponsor(s): | Reilly (42) |
| Type: | Ordinance |
| Title: | Amendment of grant(s) of privilege in public way to NM Project Company LLC - nine stone copings |
| Committee(s) Assignment: | Committee on Transportation and Public Way |

ORDINANCE AMENDMENT

Acct. No. 389577 - 1

Permit No. 1094342

BE IT ORDAINED BY THE CITY COUNCIL OF THE CITY OF CHICAGO:

Section 1:

The ordinance passed by the City Council of the City of Chicago for NM PROJECT COMPANY, LLC on 11/02/2011, and printed upon page 12022 of the Journal of Proceedings of the City of Chicago is here by Amended by deleting the words "NM PROJECT COMPANY, LLC" and inserting in their place the words "THE RESIDENCES CONDOMINIUM ON THE MAGNIFICENT MILE CONDOMINIUM ASSOCIATION"

Section 2:

This ordinance Amendment shall be in effect upon its passage.

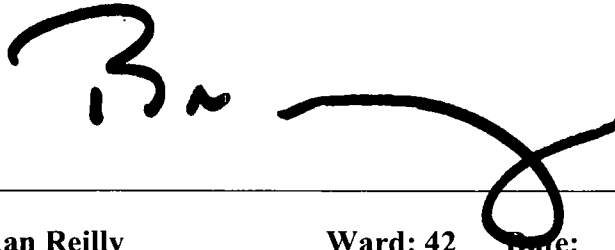
A handwritten signature in black ink, appearing to be "B. Reilly", written over a horizontal line.

ALDERMAN: _____

Brendan Reilly

Ward: 42

Date:

6-5



04/30/2014

Alderman **Brendan Reilly**
Ward # **42**
City of Chicago
City Hall, Room **306**
121 North LaSalle Street
Chicago, Illinois 60602

Re: An amended ordinance to use and maintain a portion of the public right-of-way for **nine (9) stone copings(s)** for **THE RESIDENCES CONDOMINIUM ON THE MAGNIFICENT MILE CONDOMINIUM ASSOCIATION**, adjacent to the premises known as **118 E. Eric St.**.

Dear Alderman **Brendan Reilly**:

The applicant referenced above has requested the use of the public right-of-way for a **stone copings(s)**. An ordinance has been prepared by the Department of Business Affairs and Consumer Protection – Small Business Center - Public Way Use Unit for presentation to the City Council. Because this request was made for properties located in your ward, as approved by you as per the attached, I respectfully request that you introduce the attached ordinance at the next City Council meeting.

If you have any questions regarding this ordinance, please contact Anthony Bertuca at (312) 744-5506.

Department of Business Affairs and Consumer Protection



City of Chicago



O2014-4386

Office of the City Clerk

Document Tracking Sheet

| | |
|---------------------------------|---|
| Meeting Date: | 5/28/2014 |
| Sponsor(s): | Reilly (42) |
| Type: | Ordinance |
| Title: | Amendment of grant(s) of privilege in public way to NM Project Company LLC - four sculptures |
| Committee(s) Assignment: | Committee on Transportation and Public Way |

ORDINANCE AMENDMENT

Acct. No. 389577 - 1

Permit No. 1094346

BE IT ORDAINED BY THE CITY COUNCIL OF THE CITY OF CHICAGO:

Section 1:

The ordinance passed by the City Council of the City of Chicago for NM PROJECT COMPANY, LLC on 11/02/2011, and printed upon page 12021 of the Journal of Proceedings of the City of Chicago is here by Amended by deleting the words "NM PROJECT COMPANY, LLC" and inserting in their place the words "THE RESIDENCES CONDOMINIUM ON THE MAGNIFICENT MILE CONDOMINIUM ASSOCIATION"

Section 2:

This ordinance Amendment shall be in effect upon its passage.

ALDERMAN: _____

Brendan Reilly

Ward: 42

Date: 

Handwritten signature or scribble.



04/30/2014

Alderman **Brendan Reilly**
Ward # **42**
City of Chicago
City Hall, Room **306**
121 North LaSalle Street
Chicago, Illinois 60602

Re: An amended ordinance to use and maintain a portion of the public right-of-way for **four (4) sculpture(s)** for **THE RESIDENCES CONDOMINIUM ON THE MAGNIFICENT MILE CONDOMINIUM ASSOCIATION**, adjacent to the premises known as **118 E. Erie St.**

Dear Alderman **Brendan Reilly**:

The applicant referenced above has requested the use of the public right-of-way for a **sculpture(s)**. An ordinance has been prepared by the Department of Business Affairs and Consumer Protection – Small Business Center - Public Way Use Unit for presentation to the City Council. Because this request was made for properties located in your ward, as approved by you as per the attached, I respectfully request that you introduce the attached ordinance at the next City Council meeting.

If you have any questions regarding this ordinance, please contact Anthony Bertuca at (312) 744-5506.

Department of Business Affairs and Consumer Protection



City of Chicago



O2014-4394

Office of the City Clerk

Document Tracking Sheet

| | |
|---------------------------------|---|
| Meeting Date: | 5/28/2014 |
| Sponsor(s): | Reilly (42) |
| Type: | Ordinance |
| Title: | Amendment of grant(s) of privilege in public way to NM Project Company LLC - 12 building projections |
| Committee(s) Assignment: | Committee on Transportation and Public Way |

ORDINANCE AMENDMENT

Acct. No. 389577 - 1

Permit No. 1094338

BE IT ORDAINED BY THE CITY COUNCIL OF THE CITY OF CHICAGO:

Section 1:

The ordinance passed by the City Council of the City of Chicago for NM PROJECT COMPANY, LLC on **01/13/2011**, and printed upon page **111113** of the Journal of Proceedings of the City of Chicago is here by Amended by deleting the words "NM PROJECT COMPANY, LLC" and inserting in their place the words "THE RESIDENCES CONDOMINIUM ON THE MAGNIFICENT MILE CONDOMINIUM ASSOCIATION"

Section 2:

This ordinance Amendment shall be in effect upon its passage.

ALDERMAN: _____

Brendan Reilly

Ward: 42

Date: 

Dr. J. S.



04/30/2014

Alderman **Brendan Reilly**
Ward # **42**
City of Chicago
City Hall, Room **306**
121 North LaSalle Street
Chicago, Illinois 60602

Re: An ordinance to use and maintain a portion of the public right-of-way for **twelve (12) building projection(s)** for **THE RESIDENCES CONDOMINIUM ON THE MAGNIFICENT MILE CONDOMINIUM ASSOCIATION**, adjacent to the premises known as **118 E. Erie St.**

Dear Alderman **Brendan Reilly**:

The applicant referenced above has requested the use of the public right-of-way for a **building projection(s)**. An ordinance has been prepared by the Department of Business Affairs and Consumer Protection – Small Business Center - Public Way Use Unit for presentation to the City Council. Because this request was made for properties located in your ward, as approved by you as per the attached, I respectfully request that you introduce the attached ordinance at the next City Council meeting.

If you have any questions regarding this ordinance, please contact Anthony Bertuca at (312) 744-5506.

Department of Business Affairs and Consumer Protection



City of Chicago



O2014-4402

Office of the City Clerk

Document Tracking Sheet

| | |
|---------------------------------|--|
| Meeting Date: | 5/28/2014 |
| Sponsor(s): | Reilly (42) |
| Type: | Ordinance |
| Title: | Amendment of grant(s) of privilege in public way to NM Project Company LLC - six cornices |
| Committee(s) Assignment: | Committee on Transportation and Public Way |

ORDINANCE AMENDMENT

Acct. No. 389577 - 1

Permit No. 1094344

BE IT ORDAINED BY THE CITY COUNCIL OF THE CITY OF CHICAGO:

Section 1:

The ordinance passed by the City Council of the City of Chicago for NM PROJECT COMPANY, LLC on **01/13/2011**, and printed upon page **111114** of the Journal of Proceedings of the City of Chicago is here by Amended by deleting the words "NM PROJECT COMPANY, LLC" and inserting in their place the words "THE RESIDENCES CONDOMINIUM ON THE MAGNIFICENT MILE CONDOMINIUM ASSOCIATION"

Section 2:

This ordinance Amendment shall be in effect upon its passage.

ALDERMAN: _____

Brendan Reilly

Ward: 42

Date:

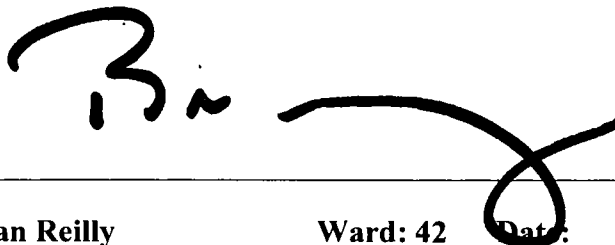
A large, stylized handwritten signature in black ink, appearing to read 'B. Reilly', is written over a horizontal line. The signature is positioned above the printed name 'Brendan Reilly' and the printed text 'Ward: 42' and 'Date:'. The signature is written in a cursive style with a large loop at the end.

5-9



04/30/2014

Alderman **Brendan Reilly**
Ward # **42**
City of Chicago
City Hall, Room **306**
121 North LaSalle Street
Chicago, Illinois 60602

Re: An amended ordinance to use and maintain a portion of the public right-of-way for **six (6) cornice(s)** for **THE RESIDENCES CONDOMINIUM ON THE MAGNIFICENT MILE CONDOMINIUM ASSOCIATION**, adjacent to the premises known as **118 E. Erie St.**

Dear Alderman **Brendan Reilly**:

The applicant referenced above has requested the use of the public right-of-way for a **cornice(s)**. An ordinance has been prepared by the Department of Business Affairs and Consumer Protection – Small Business Center - Public Way Use Unit for presentation to the City Council. Because this request was made for properties located in your ward, as approved by you as per the attached, I respectfully request that you introduce the attached ordinance at the next City Council meeting.

If you have any questions regarding this ordinance, please contact Anthony Bertuca at (312) 744-5506.

Department of Business Affairs and Consumer Protection



City of Chicago



O2014-4410

Office of the City Clerk

Document Tracking Sheet

| | |
|---------------------------------|--|
| Meeting Date: | 5/28/2014 |
| Sponsor(s): | Reilly (42) |
| Type: | Ordinance |
| Title: | Amendment of grant(s) of privilege in public way to NM Project Company LLC - 12 exterior mounts |
| Committee(s) Assignment: | Committee on Transportation and Public Way |

ORDINANCE AMENDMENT

Acct. No. 389577 - 1

Permit No. 1094340

BE IT ORDAINED BY THE CITY COUNCIL OF THE CITY OF CHICAGO:

Section 1:

The ordinance passed by the City Council of the City of Chicago for NM PROJECT COMPANY, LLC on **01/13/2011**, and printed upon page **111115** of the Journal of Proceedings of the City of Chicago is here by Amended by deleting the words "NM PROJECT COMPANY, LLC" and inserting in their place the words "THE RESIDENCES CONDOMINIUM ON THE MAGNIFICENT MILE CONDOMINIUM ASSOCIATION"

Section 2:

This ordinance Amendment shall be in effect upon its passage.

ALDERMAN: _____

Brendan Reilly

Ward: 42

Date:

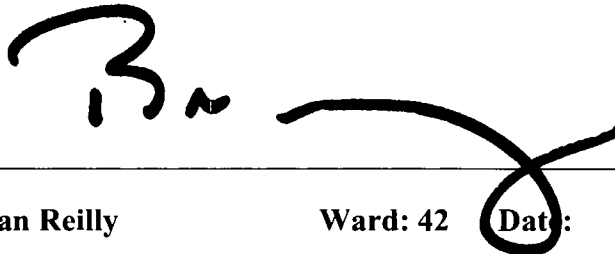
A large, stylized handwritten signature in black ink, appearing to read 'B. Reilly', is written over a horizontal line. The signature is positioned above the printed name 'Brendan Reilly' and the 'Date:' label.

Handwritten signature or scribble.



04/30/2014

Alderman **Brendan Reilly**
Ward # **42**
City of Chicago
City Hall, Room **306**
121 North LaSalle Street
Chicago, Illinois 60602

Re: An amended ordinance to use and maintain a portion of the public right-of-way for **twelve (12) exterior mount(s)** for **THE RESIDENCES CONDOMINIUM ON THE MAGNIFICENT MILE CONDOMINIUM ASSOCIATION**, adjacent to the premises known as **118 E. Erie St.**.

Dear Alderman **Brendan Reilly**:

The applicant referenced above has requested the use of the public right-of-way for a **exterior mount(s)**. An ordinance has been prepared by the Department of Business Affairs and Consumer Protection – Small Business Center - Public Way Use Unit for presentation to the City Council. Because this request was made for properties located in your ward, as approved by you as per the attached, I respectfully request that you introduce the attached ordinance at the next City Council meeting.

If you have any questions regarding this ordinance, please contact Anthony Bertuca at (312) 744-5506.

Department of Business Affairs and Consumer Protection



City of Chicago



O2014-4415

Office of the City Clerk

Document Tracking Sheet

| | |
|---------------------------------|--|
| Meeting Date: | 5/28/2014 |
| Sponsor(s): | Reilly (42) |
| Type: | Ordinance |
| Title: | Amendment of grant(s) of privilege in public way to NM Project Company LLC - four balconies |
| Committee(s) Assignment: | Committee on Transportation and Public Way |

ORDINANCE AMENDMENT

Acct. No. 389577 - 1

Permit No. 1094337

BE IT ORDAINED BY THE CITY COUNCIL OF THE CITY OF CHICAGO:

Section 1:

The ordinance passed by the City Council of the City of Chicago for NM PROJECT COMPANY, on 03/09/2011, and printed upon page 113834 of the Journal of Proceedings of the City of Chicago is here by Amended by deleting the words "NM PROJECT COMPANY, LLC" and inserting in their place the words "THE RESIDENCES CONDOMINIUM ON THE MAGNIFICENT MILE CONDOMINIUM ASSOCIATION"

Section 2:

This ordinance Amendment shall be in effect upon its passage.

ALDERMAN: _____

Brendan Reilly

Ward: 42

Date: 

55-9



04/30/2014

Alderman **Brendan Reilly**
Ward # **42**
City of Chicago
City Hall, Room **306**
121 North LaSalle Street
Chicago, Illinois 60602

Re: An amended ordinance to use and maintain a portion of the public right-of-way for **four (4) balcony(ies)** for **THE RESIDENCES CONDOMINIUM ON THE MAGNIFICENT MILE CONDOMINIUM ASSOCIATION**, adjacent to the premises known as **118 E. Erie St.**

Dear Alderman **Brendan Reilly**:

The applicant referenced above has requested the use of the public right-of-way for a **balcony(ies)**. An ordinance has been prepared by the Department of Business Affairs and Consumer Protection – Small Business Center - Public Way Use Unit for presentation to the City Council. Because this request was made for properties located in your ward, as approved by you as per the attached, I respectfully request that you introduce the attached ordinance at the next City Council meeting.

If you have any questions regarding this ordinance, please contact Anthony Bertuca at (312) 744-5506.

Department of Business Affairs and Consumer Protection



City of Chicago



O2014-4425

Office of the City Clerk

Document Tracking Sheet

| | |
|---------------------------------|--|
| Meeting Date: | 5/28/2014 |
| Sponsor(s): | Reilly (42) |
| Type: | Ordinance |
| Title: | Amendment of grant(s) of privilege in public way to NM Project Company LLC - four facades |
| Committee(s) Assignment: | Committee on Transportation and Public Way |

ORDINANCE AMENDMENT

Acct. No. 389577 - 1

Permit No. 1094345

BE IT ORDAINED BY THE CITY COUNCIL OF THE CITY OF CHICAGO:

Section 1:

The ordinance passed by the City Council of the City of Chicago for NM PROJECT COMPANY, LLC on **01/18/2012**, and printed upon page **19374** of the Journal of Proceedings of the City of Chicago is here by Amended by deleting the words "NM PROJECT COMPANY, LLC" and inserting in their place the words "THE RESIDENCES CONDOMINIUM ON THE MAGNIFICENT MILE CONDOMINIUM ASSOCIATION"

Section 2:

This ordinance Amendment shall be in effect upon its passage.

ALDERMAN: _____

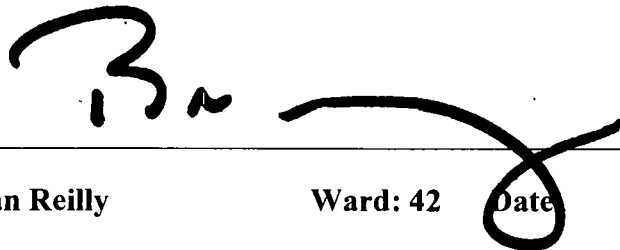
A large, stylized handwritten signature in black ink, appearing to read 'B. Reilly', is written over a horizontal line. The signature is written in a cursive style with a large initial 'B' and a long, sweeping underline.

Brendan Reilly

Ward: 42

Date

5-10



04/30/2014

Alderman **Brendan Reilly**
Ward # **42**
City of Chicago
City Hall, Room **306**
121 North LaSalle Street
Chicago, Illinois 60602

Re: An amended ordinance to use and maintain a portion of the public right-of-way for **four (4) facade(s)** for **THE RESIDENCES CONDOMINIUM ON THE MAGNIFICENT MILE CONDOMINIUM ASSOCIATION**, adjacent to the premises known as **118 E. Erie St.**

Dear Alderman **Brendan Reilly**:

The applicant referenced above has requested the use of the public right-of-way for a **facade(s)**. An ordinance has been prepared by the Department of Business Affairs and Consumer Protection – Small Business Center - Public Way Use Unit for presentation to the City Council. Because this request was made for properties located in your ward, as approved by you as per the attached, I respectfully request that you introduce the attached ordinance at the next City Council meeting.

If you have any questions regarding this ordinance, please contact Anthony Bertuca at (312) 744-5506.

Department of Business Affairs and Consumer Protection



City of Chicago



O2014-4441

Office of the City Clerk

Document Tracking Sheet

| | |
|---------------------------------|--|
| Meeting Date: | 5/28/2014 |
| Sponsor(s): | Reilly (42) |
| Type: | Ordinance |
| Title: | Amendment of grant(s) of privilege in public way to NM Project Company LLC - one sheeting |
| Committee(s) Assignment: | Committee on Transportation and Public Way |

ORDINANCE AMENDMENT

Acct. No. 389577 - 1

Permit No. 1098857

BE IT ORDAINED BY THE CITY COUNCIL OF THE CITY OF CHICAGO:

Section 1:

The ordinance passed by the City Council of the City of Chicago for NM PROJECT COMPANY, LLC on **02/15/2012**, and printed upon page **20766** of the Journal of Proceedings of the City of Chicago is here by Amended by deleting the words "NM PROJECT COMPANY, LLC" and inserting in their place the words "THE RESIDENCES CONDOMINIUM ON THE MAGNIFICENT MILE CONDOMINIUM ASSOCIATION"

Section 2:

This ordinance Amendment shall be in effect upon its passage.

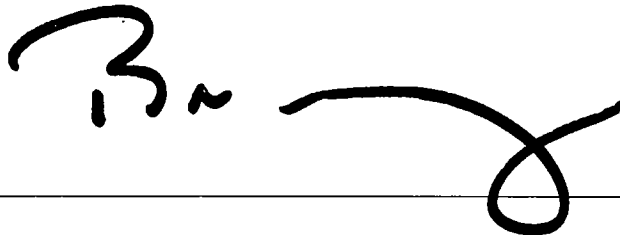
A handwritten signature in black ink, appearing to read 'B. Reilly', written over a horizontal line.

ALDERMAN: _____

Brendan Reilly

Ward: 42

Date:

Handwritten signature or scribble



04/30/2014

Alderman **Brendan Reilly**
Ward # **42**
City of Chicago
City Hall, Room **306**
121 North LaSalle Street
Chicago, Illinois 60602

Re: An amended ordinance to use and maintain a portion of the public right-of-way for **one (1) sheeting(s)** for **THE RESIDENCES CONDOMINIUM ON THE MAGNIFICENT MILE CONDOMINIUM ASSOCIATION**, adjacent to the premises known as **118 E. Erie St.**

Dear Alderman **Brendan Reilly**:

The applicant referenced above has requested the use of the public right-of-way for a **sheeting(s)**. An ordinance has been prepared by the Department of Business Affairs and Consumer Protection – Small Business Center - Public Way Use Unit for presentation to the City Council. Because this request was made for properties located in your ward, as approved by you as per the attached, I respectfully request that you introduce the attached ordinance at the next City Council meeting.

If you have any questions regarding this ordinance, please contact Anthony Bertuca at (312) 744-5506.

Department of Business Affairs and Consumer Protection



City of Chicago



O2014-4445

Office of the City Clerk

Document Tracking Sheet

| | |
|---------------------------------|--|
| Meeting Date: | 5/28/2014 |
| Sponsor(s): | Reilly (42) |
| Type: | Ordinance |
| Title: | Amendment of grant(s) of privilege in public way to NM Project Company LLC - one elevator |
| Committee(s) Assignment: | Committee on Transportation and Public Way |

ORDINANCE AMENDMENT

Acct. No. 389577 - 1

Permit No. 1098973

BE IT ORDAINED BY THE CITY COUNCIL OF THE CITY OF CHICAGO:

Section 1:

The ordinance passed by the City Council of the City of Chicago for NM PROJECT COMPANY, LLC on **02/15/2012**, and printed upon page **20766** of the Journal of Proceedings of the City of Chicago is here by Amended by deleting the words "NM PROJECT COMPANY, LLC" and inserting in their place the words "THE RESIDENCES CONDOMINIUM ON THE MAGNIFICENT MILE CONDOMINIUM ASSOCIATION"

Section 2:

This ordinance Amendment shall be in effect upon its passage.

ALDERMAN: _____

Brendan Reilly

Ward: 42

Date:

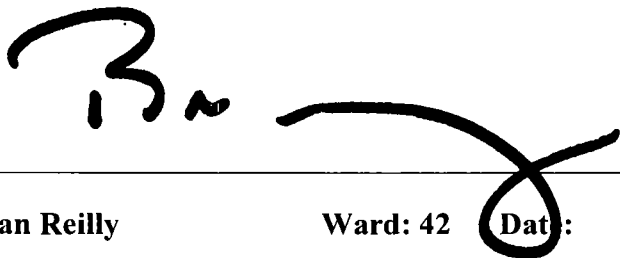
A large, stylized handwritten signature in black ink, appearing to read 'B. Reilly', is written over a horizontal line. The signature is positioned above the printed name 'Brendan Reilly' and the 'Date:' label.

5. 9



04/30/2014

Alderman **Brendan Reilly**
Ward # **42**
City of Chicago
City Hall, Room **306**
121 North LaSalle Street
Chicago, Illinois 60602

Re: An amended ordinance to use and maintain a portion of the public right-of-way for **one (1) elevator(s)** for **THE RESIDENCES CONDOMINIUM ON THE MAGNIFICENT MILE CONDOMINIUM ASSOCIATION**, adjacent to the premises known as **118 E. Erie St.**

Dear Alderman **Brendan Reilly**:

The applicant referenced above has requested the use of the public right-of-way for a **elevator(s)**. An ordinance has been prepared by the Department of Business Affairs and Consumer Protection – Small Business Center - Public Way Use Unit for presentation to the City Council. Because this request was made for properties located in your ward, as approved by you as per the attached, I respectfully request that you introduce the attached ordinance at the next City Council meeting.

If you have any questions regarding this ordinance, please contact Anthony Bertuca at (312) 744-5506.

Department of Business Affairs and Consumer Protection



City of Chicago



O2014-4470

Office of the City Clerk

Document Tracking Sheet

| | |
|---------------------------------|---|
| Meeting Date: | 5/28/2014 |
| Sponsor(s): | Reilly (42) |
| Type: | Ordinance |
| Title: | Amendment of grant(s) of privilege in public way to NM Project Company LLC - one vault |
| Committee(s) Assignment: | Committee on Transportation and Public Way |

ORDINANCE AMENDMENT

Acct. No. 389577 - 1

Permit No. 1098858

BE IT ORDAINED BY THE CITY COUNCIL OF THE CITY OF CHICAGO:

Section 1:

The ordinance passed by the City Council of the City of Chicago for NM PROJECT COMPANY, LLC on **02/15/2012**, and printed upon page **20767** of the Journal of Proceedings of the City of Chicago is here by Amended by deleting the words "NM PROJECT COMPANY, LLC" and inserting in their place the words "THE RESIDENCES CONDOMINIUM ON THE MAGNIFICENT MILE CONDOMINIUM ASSOCIATION"

Section 2:

This ordinance Amendment shall be in effect upon its passage.

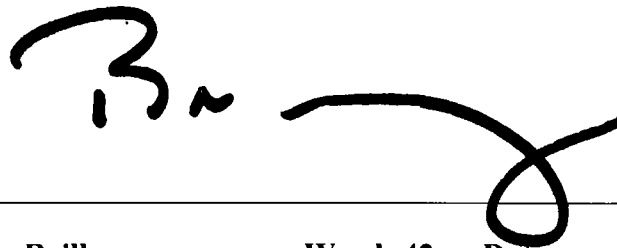
A handwritten signature in black ink, appearing to read "B. Reilly", written over a horizontal line.

ALDERMAN: _____

Brendan Reilly

Ward: 42

Date:

5. 2



04/30/2014

Alderman **Brendan Reilly**
Ward # **42**
City of Chicago
City Hall, Room **306**
121 North LaSalle Street
Chicago, Illinois 60602

Re: An amended ordinance to use and maintain a portion of the public right-of-way for **one (1) vault(s)** for **THE RESIDENCES CONDOMINIUM ON THE MAGNIFICENT MILE CONDOMINIUM ASSOCIATION**, adjacent to the premises known as **118 W. Erie St.**

Dear Alderman **Brendan Reilly**:

The applicant referenced above has requested the use of the public right-of-way for a **vault(s)**. An ordinance has been prepared by the Department of Business Affairs and Consumer Protection – Small Business Center - Public Way Use Unit for presentation to the City Council. Because this request was made for properties located in your ward, as approved by you as per the attached, I respectfully request that you introduce the attached ordinance at the next City Council meeting.

If you have any questions regarding this ordinance, please contact Anthony Bertuca at (312) 744-5506.

Department of Business Affairs and Consumer Protection



City of Chicago



O2014-4474

Office of the City Clerk

Document Tracking Sheet

| | |
|---------------------------------|---|
| Meeting Date: | 5/28/2014 |
| Sponsor(s): | Reilly (42) |
| Type: | Ordinance |
| Title: | Amendment of grant(s) of privilege in public way to Next Randolph & Wells Park |
| Committee(s) Assignment: | Committee on Transportation and Public Way |

ORDINANCE AMENDMENT

Acct. No. 63376 - 193

Permit No. 1108294

BE IT ORDAINED BY THE CITY COUNCIL OF THE CITY OF CHICAGO:

Section 1:

The ordinance passed by the City Council of the City of Chicago for NEXT RANDOLPH & WELLS PARK on **10/16/2013**, and printed upon page **62216** of the Journal of Proceedings of the City of Chicago is here by Amended by deleting the words "NEXT RANDOLPH & WELLS PARK" and inserting in their place the words "INTERPARK "

Section 2:

This ordinance Amendment shall be in effect upon its passage.

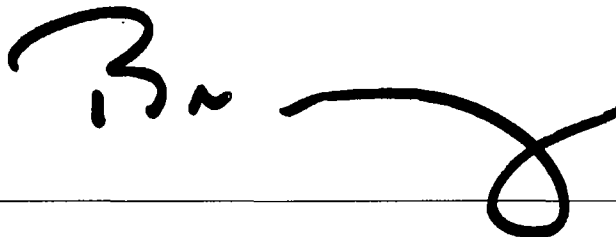

ALDERMAN: _____

Brendan Reilly

Ward: 42

Date:

Handwritten signature or scribble, possibly containing the characters "S" and "O".



City of Chicago



O2014-4295

Office of the City Clerk Document Tracking Sheet

| | |
|---------------------------------|--|
| Meeting Date: | 5/28/2014 |
| Sponsor(s): | Silverstein (50) |
| Type: | Ordinance |
| Title: | Amendment of grant(s) of privilege in public way to Alibis |
| Committee(s) Assignment: | Committee on Transportation and Public Way |

ORDINANCE AMENDMENT

Acct. No. 4068 - 1

Permit No. 1109279

BE IT ORDAINED BY THE CITY COUNCIL OF THE CITY OF CHICAGO:

Section 1:

The ordinance passed by the City Council of the City of Chicago for **ALIBIS** on **01/15/2014**, and printed upon page **73067** of the Journal of Proceedings of the City of Chicago is here by Amended by deleting the words

“one (100) feet in length”

and inserting in their place the words

“ten (10) feet in length”

Section 2:

This ordinance Amendment shall be in effect upon its passage.

ALDERMAN:

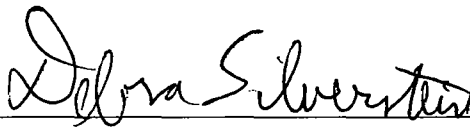

Debra L. Silverstein

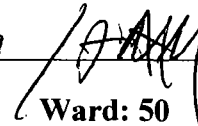

Ward: 50

Date:



City of Chicago



Or2014-251

Office of the City Clerk

Document Tracking Sheet

| | |
|---------------------------------|---|
| Meeting Date: | 5/28/2014 |
| Sponsor(s): | Smith (43) |
| Type: | Order |
| Title: | Historical landmark fee waiver for 518 W Fullerton Pkwy |
| Committee(s) Assignment: | Committee on Zoning, Landmarks and Building Standards |

ORDER

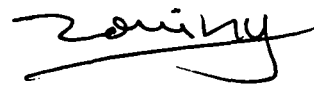

WHEREAS, Section 2-120-815 of the Municipal Code provides that the Chicago City Council may by passage of an appropriate order waive any fees charged by the City for any permit for which approval of the Commission on Chicago Landmarks (the "Commission") is required, in accordance with chapter 2-120 of the Municipal Code; and

WHEREAS, the permits identified below require Commission approval, in accordance with Section 2-120-740 of the Municipal Code; now, therefore,

BE IT ORDAINED BY THE CITY COUNCIL OF THE CITY OF CHICAGO:

SECTION 1. The foregoing recitals are hereby adopted as the findings of the City Council.

SECTION 2. The Commissioner of the Department of Buildings, the Commissioners of the Departments of Environment and Fire, the Director of the Department of Revenue, and the Zoning Administrator are hereby directed to issue those permits for which approval of the Commission on Chicago Landmarks is required pursuant to Chapter 2-120 of the Municipal Code free of charge, notwithstanding any other ordinances of the City Council to the contrary, for the property at:

Address: 518 West Fullerton Pkwy ("Property")
District/Building: Mid-North District

for work generally described as: Residential rehabilitation of an existing 3-flat property, to include the reconditioning of the basement to be used as livable space.

Owner: 518 Fullerton, LLC
Owner's Address: 3654 N. Lincoln
City, State, Zip: Chicago, Illinois 60613

SECTION 3. The fee waiver authorized by this Order shall be effective from February 1, 2014 through February 1, 2015, and shall not apply to **additional developer service fees, stop-work order fees or any fines.**

SECTION 4. This order shall be in force and effect upon its passage.

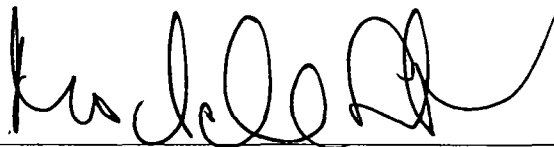

Michele Smith
Alderman, 43rd Ward

NOTE: This is NOT a permit nor does it constitute a Letter of Approval for the above described work. A permit application for the work must be approved by the appropriate City department(s) as well as the Commission on Chicago Landmarks for this permit fee waiver, subject to City Council approval, to be valid.

**CITY OF CHICAGO
ECONOMIC DISCLOSURE STATEMENT
AND AFFIDAVIT**

SECTION I -- GENERAL INFORMATION

A. Legal name of the Disclosing Party submitting this EDS. Include d/b/a/ if applicable:

518 FULLERTON, LLC

Check ONE of the following three boxes:

Indicate whether the Disclosing Party submitting this EDS is:

1. the Applicant

OR

2. a legal entity holding a direct or indirect interest in the Applicant. State the legal name of the Applicant in which the Disclosing Party holds an interest: _____

OR

3. a legal entity with a right of control (see Section II.B.1.) State the legal name of the entity in which the Disclosing Party holds a right of control: _____

B. Business address of the Disclosing Party:

3654 N. US COVE
CHICAGO, IL 60613

C. Telephone: 773-435-0447 Fax: 773-472-4738 Email: tiago.pappas@gmail.com

D. Name of contact person: TIAGO PAPPAS

E. Federal Employer Identification No. (if you have one): _____

F. Brief description of contract, transaction or other undertaking (referred to below as the "Matter") to which this EDS pertains. (Include project number and location of property, if applicable):

PERMIT FEE WAIVER AT 518 W. FULLERTON PKWY
BUREAU OF PLANNING AND ZONING

G. Which City agency or department is requesting this EDS? HISTORIC PRESERVATION DIVISION

If the Matter is a contract being handled by the City's Department of Procurement Services, please complete the following:

Specification # _____ and Contract # _____

SECTION II -- DISCLOSURE OF OWNERSHIP INTERESTS

A. NATURE OF THE DISCLOSING PARTY

1. Indicate the nature of the Disclosing Party:

- Person
- Publicly registered business corporation
- Privately held business corporation
- Sole proprietorship
- General partnership
- Limited partnership
- Trust
- Limited liability company
- Limited liability partnership
- Joint venture
- Not-for-profit corporation
(Is the not-for-profit corporation also a 501(c)(3))?
 Yes No
- Other (please specify)

2. For legal entities, the state (or foreign country) of incorporation or organization, if applicable:

ALASKA

3. For legal entities not organized in the State of Illinois: Has the organization registered to do business in the State of Illinois as a foreign entity?

- Yes No N/A

B. IF THE DISCLOSING PARTY IS A LEGAL ENTITY:

1. List below the full names and titles of all executive officers and all directors of the entity.

NOTE: For not-for-profit corporations, also list below all members, if any, which are legal entities. If there are no such members, write "no members." For trusts, estates or other similar entities, list below the legal titleholder(s).

If the entity is a general partnership, limited partnership, limited liability company, limited liability partnership or joint venture, list below the name and title of each general partner, managing member, manager or any other person or entity that controls the day-to-day management of the Disclosing Party.

NOTE: Each legal entity listed below must submit an EDS on its own behalf.

| Name | Title |
|-------------------------------|---------|
| CHICAGO APARTMENT PLACE, INC. | MANAGER |
| | |
| | |
| | |

2. Please provide the following information concerning each person or entity having a direct or indirect beneficial interest (including ownership) in excess of 7.5% of the Disclosing Party. Examples of such an interest include shares in a corporation, partnership interest in a partnership or joint venture,

interest of a member or manager in a limited liability company, or interest of a beneficiary of a trust, estate or other similar entity. If none, state "None." **NOTE:** Pursuant to Section 2-154-030 of the Municipal Code of Chicago ("Municipal Code"), the City may require any such additional information from any applicant which is reasonably intended to achieve full disclosure.

| Name | Business Address | Percentage Interest in the Disclosing Party |
|----------------------------|---------------------------------------|---|
| PHILIP PAPPAS | IRREVOCABLE GIFT TRUST DATED 12-20-12 | 50% |
| 3654 N. LINCOLN | CHICAGO, IL 60613 | |
| ANA LUCIA SANT'ANNA PAPPAS | IRREVOCABLE GIFT TRUST DATED 12-8-12 | 50% |
| 3654 N. LINCOLN | CHICAGO, IL 60613 | |

SECTION III -- BUSINESS RELATIONSHIPS WITH CITY ELECTED OFFICIALS

Has the Disclosing Party had a "business relationship," as defined in Chapter 2-156 of the Municipal Code, with any City elected official in the 12 months before the date this EDS is signed?

Yes No

If yes, please identify below the name(s) of such City elected official(s) and describe such relationship(s):

SECTION IV -- DISCLOSURE OF SUBCONTRACTORS AND OTHER RETAINED PARTIES

The Disclosing Party must disclose the name and business address of each subcontractor, attorney, lobbyist, accountant, consultant and any other person or entity whom the Disclosing Party has retained or expects to retain in connection with the Matter, as well as the nature of the relationship, and the total amount of the fees paid or estimated to be paid. The Disclosing Party is not required to disclose employees who are paid solely through the Disclosing Party's regular payroll.

"Lobbyist" means any person or entity who undertakes to influence any legislative or administrative action on behalf of any person or entity other than: (1) a not-for-profit entity, on an unpaid basis, or (2) himself. "Lobbyist" also means any person or entity any part of whose duties as an employee of another includes undertaking to influence any legislative or administrative action.

If the Disclosing Party is uncertain whether a disclosure is required under this Section, the Disclosing Party must either ask the City whether disclosure is required or make the disclosure.

| Name (indicate whether retained or anticipated to be retained) | Business Address | Relationship to Disclosing Party (subcontractor, attorney, lobbyist, etc.) | Fees (indicate whether paid or estimated.) NOTE: "hourly rate" or "t.b.d." is not an acceptable response. |
|--|------------------|--|---|
|--|------------------|--|---|

| | | | |
|--------------------------|----------------------------------|-----------|----------|
| JOEL BERMAN ARCHITECTURE | 5212 N. CLARK, CHICAGO, IL 60640 | ARCHITECT | \$21,000 |
|--------------------------|----------------------------------|-----------|----------|

| | | | |
|-------------------------------|------------------------------------|--------------------|--|
| CHICAGO APARTMENT FLARE, INC. | 3654 N. LINCOLN, CHICAGO, IL 60613 | GENERAL CONTRACTOR | |
|-------------------------------|------------------------------------|--------------------|--|

→ BOTH RETAINED \$988,900

(Add sheets if necessary)

Check here if the Disclosing Party has not retained, nor expects to retain, any such persons or entities.

SECTION V -- CERTIFICATIONS

A. COURT-ORDERED CHILD SUPPORT COMPLIANCE

Under Municipal Code Section 2-92-415, substantial owners of business entities that contract with the City must remain in compliance with their child support obligations throughout the contract's term.

Has any person who directly or indirectly owns 10% or more of the Disclosing Party been declared in arrearage on any child support obligations by any Illinois court of competent jurisdiction?

Yes No No person directly or indirectly owns 10% or more of the Disclosing Party.

If "Yes," has the person entered into a court-approved agreement for payment of all support owed and is the person in compliance with that agreement?

Yes No

B. FURTHER CERTIFICATIONS

1. Pursuant to Municipal Code Chapter 1-23, Article I ("Article I")(which the Applicant should consult for defined terms (e.g., "doing business") and legal requirements), if the Disclosing Party submitting this EDS is the Applicant and is doing business with the City, then the Disclosing Party certifies as follows: (i) neither the Applicant nor any controlling person is currently indicted or charged with, or has admitted guilt of, or has ever been convicted of, or placed under supervision for, any criminal offense involving actual, attempted, or conspiracy to commit bribery, theft, fraud, forgery, perjury, dishonesty or deceit against an officer or employee of the City or any sister agency; and (ii) the Applicant understands and acknowledges that compliance with Article I is a continuing requirement for doing business with the City. NOTE: If Article I applies to the Applicant, the permanent compliance timeframe in Article I supersedes some five-year compliance timeframes in certifications 2 and 3 below.

2. The Disclosing Party and, if the Disclosing Party is a legal entity, all of those persons or entities identified in Section II.B.1. of this EDS:

- a. are not presently debarred, suspended, proposed for debarment, declared ineligible or voluntarily excluded from any transactions by any federal, state or local unit of government;
- b. have not, within a five-year period preceding the date of this EDS, been convicted of a criminal offense, adjudged guilty, or had a civil judgment rendered against them in connection with: obtaining, attempting to obtain, or performing a public (federal, state or local) transaction or contract under a public transaction; a violation of federal or state antitrust statutes; fraud; embezzlement; theft; forgery; bribery; falsification or destruction of records; making false statements; or receiving stolen property;
- c. are not presently indicted for, or criminally or civilly charged by, a governmental entity (federal, state or local) with committing any of the offenses set forth in clause B.2.b. of this Section V;
- d. have not, within a five-year period preceding the date of this EDS, had one or more public transactions (federal, state or local) terminated for cause or default; and
- e. have not, within a five-year period preceding the date of this EDS, been convicted, adjudged guilty, or found liable in a civil proceeding, or in any criminal or civil action, including actions concerning environmental violations, instituted by the City or by the federal government, any state, or any other unit of local government.

3. The certifications in subparts 3, 4 and 5 concern:

- the Disclosing Party;
- any "Contractor" (meaning any contractor or subcontractor used by the Disclosing Party in connection with the Matter, including but not limited to all persons or legal entities disclosed under Section IV, "Disclosure of Subcontractors and Other Retained Parties");
- any "Affiliated Entity" (meaning a person or entity that, directly or indirectly: controls the Disclosing Party, is controlled by the Disclosing Party, or is, with the Disclosing Party, under common control of another person or entity. Indicia of control include, without limitation: interlocking management or ownership; identity of interests among family members, shared facilities and equipment; common use of employees; or organization of a business entity following the ineligibility of a business entity to do business with federal or state or local government, including the City, using substantially the same management, ownership, or principals as the ineligible entity); with respect to Contractors, the term Affiliated Entity means a person or entity that directly or indirectly controls the Contractor, is controlled by it, or, with the Contractor, is under common control of another person or entity;
- any responsible official of the Disclosing Party, any Contractor or any Affiliated Entity or any other official, agent or employee of the Disclosing Party, any Contractor or any Affiliated Entity, acting pursuant to the direction or authorization of a responsible official of the Disclosing Party, any Contractor or any Affiliated Entity (collectively "Agents").

Neither the Disclosing Party, nor any Contractor, nor any Affiliated Entity of either the Disclosing Party or any Contractor nor any Agents have, during the five years before the date this EDS is signed, or, with respect to a Contractor, an Affiliated Entity, or an Affiliated Entity of a Contractor during the five years before the date of such Contractor's or Affiliated Entity's contract or engagement in connection with the Matter:

- a. bribed or attempted to bribe, or been convicted or adjudged guilty of bribery or attempting to bribe, a public officer or employee of the City, the State of Illinois, or any agency of the federal government or of any state or local government in the United States of America, in that officer's or employee's official capacity;
- b. agreed or colluded with other bidders or prospective bidders, or been a party to any such agreement, or been convicted or adjudged guilty of agreement or collusion among bidders or prospective bidders, in restraint of freedom of competition by agreement to bid a fixed price or otherwise; or
- c. made an admission of such conduct described in a. or b. above that is a matter of record, but have not been prosecuted for such conduct; or
- d. violated the provisions of Municipal Code Section 2-92-610 (Living Wage Ordinance).

4. Neither the Disclosing Party, Affiliated Entity or Contractor, or any of their employees, officials, agents or partners, is barred from contracting with any unit of state or local government as a result of engaging in or being convicted of (1) bid-rigging in violation of 720 ILCS 5/33E-3; (2) bid-rotating in violation of 720 ILCS 5/33E-4; or (3) any similar offense of any state or of the United States of America that contains the same elements as the offense of bid-rigging or bid-rotating.

5. Neither the Disclosing Party nor any Affiliated Entity is listed on any of the following lists maintained by the Office of Foreign Assets Control of the U.S. Department of the Treasury or the Bureau of Industry and Security of the U.S. Department of Commerce or their successors: the Specially Designated Nationals List, the Denied Persons List, the Unverified List, the Entity List and the Debarred List.

6. The Disclosing Party understands and shall comply with the applicable requirements of Chapters 2-55 (Legislative Inspector General), 2-56 (Inspector General) and 2-156 (Governmental Ethics) of the Municipal Code.

7. If the Disclosing Party is unable to certify to any of the above statements in this Part B (Further Certifications), the Disclosing Party must explain below:

If the letters "NA," the word "None," or no response appears on the lines above, it will be conclusively presumed that the Disclosing Party certified to the above statements.

8. To the best of the Disclosing Party's knowledge after reasonable inquiry, the following is a complete list of all current employees of the Disclosing Party who were, at any time during the 12-month period preceding the execution date of this EDS, an employee, or elected or appointed official, of the City of Chicago (if none, indicate with "N/A" or "none").

— N/A

9. To the best of the Disclosing Party's knowledge after reasonable inquiry, the following is a complete list of all gifts that the Disclosing Party has given or caused to be given, at any time during the 12-month period preceding the execution date of this EDS, to an employee, or elected or appointed official, of the City of Chicago. For purposes of this statement, a "gift" does not include: (i) anything made generally available to City employees or to the general public, or (ii) food or drink provided in the course of official City business and having a retail value of less than \$20 per recipient (if none, indicate with "N/A" or "none"). As to any gift listed below, please also list the name of the City recipient.

— N/A

C. CERTIFICATION OF STATUS AS FINANCIAL INSTITUTION

1. The Disclosing Party certifies that the Disclosing Party (check one)

is is not

a "financial institution" as defined in Section 2-32-455(b) of the Municipal Code.

2. If the Disclosing Party IS a financial institution, then the Disclosing Party pledges:

"We are not and will not become a predatory lender as defined in Chapter 2-32 of the Municipal Code. We further pledge that none of our affiliates is, and none of them will become, a predatory lender as defined in Chapter 2-32 of the Municipal Code. We understand that becoming a predatory lender or becoming an affiliate of a predatory lender may result in the loss of the privilege of doing business with the City."

If the Disclosing Party is unable to make this pledge because it or any of its affiliates (as defined in Section 2-32-455(b) of the Municipal Code) is a predatory lender within the meaning of Chapter 2-32 of the Municipal Code, explain here (attach additional pages if necessary):

—

If the letters "NA," the word "None," or no response appears on the lines above, it will be conclusively presumed that the Disclosing Party certified to the above statements.

D. CERTIFICATION REGARDING INTEREST IN CITY BUSINESS

Any words or terms that are defined in Chapter 2-156 of the Municipal Code have the same meanings when used in this Part D.

1. In accordance with Section 2-156-110 of the Municipal Code: Does any official or employee of the City have a financial interest in his or her own name or in the name of any other person or entity in the Matter?

Yes No

NOTE: If you checked "Yes" to Item D.1., proceed to Items D.2. and D.3. If you checked "No" to Item D.1., proceed to Part E.

2. Unless sold pursuant to a process of competitive bidding, or otherwise permitted, no City elected official or employee shall have a financial interest in his or her own name or in the name of any other person or entity in the purchase of any property that (i) belongs to the City, or (ii) is sold for taxes or assessments, or (iii) is sold by virtue of legal process at the suit of the City (collectively, "City Property Sale"). Compensation for property taken pursuant to the City's eminent domain power does not constitute a financial interest within the meaning of this Part D.

Does the Matter involve a City Property Sale?

Yes No

3. If you checked "Yes" to Item D.1., provide the names and business addresses of the City officials or employees having such interest and identify the nature of such interest:

| Name | Business Address | Nature of Interest |
|------|------------------|--------------------|
| | | |
| | | |
| | | |

4. The Disclosing Party further certifies that no prohibited financial interest in the Matter will be acquired by any City official or employee.

E. CERTIFICATION REGARDING SLAVERY ERA BUSINESS

Please check either 1. or 2. below. If the Disclosing Party checks 2., the Disclosing Party must disclose below or in an attachment to this EDS all information required by paragraph 2. Failure to

comply with these disclosure requirements may make any contract entered into with the City in connection with the Matter voidable by the City.

✓ 1. The Disclosing Party verifies that the Disclosing Party has searched any and all records of the Disclosing Party and any and all predecessor entities regarding records of investments or profits from slavery or slaveholder insurance policies during the slavery era (including insurance policies issued to slaveholders that provided coverage for damage to or injury or death of their slaves), and the Disclosing Party has found no such records.

2. The Disclosing Party verifies that, as a result of conducting the search in step 1 above, the Disclosing Party has found records of investments or profits from slavery or slaveholder insurance policies. The Disclosing Party verifies that the following constitutes full disclosure of all such records, including the names of any and all slaves or slaveholders described in those records:

SECTION VI -- CERTIFICATIONS FOR FEDERALLY FUNDED MATTERS

NOTE: If the Matter is federally funded, complete this Section VI. **If the Matter is not federally funded**, proceed to Section VII. For purposes of this Section VI, tax credits allocated by the City and proceeds of debt obligations of the City are not federal funding.

A. CERTIFICATION REGARDING LOBBYING

1. List below the names of all persons or entities registered under the federal Lobbying Disclosure Act of 1995 who have made lobbying contacts on behalf of the Disclosing Party with respect to the Matter: (Add sheets if necessary):

(If no explanation appears or begins on the lines above, or if the letters "NA" or if the word "None" appear, it will be conclusively presumed that the Disclosing Party means that NO persons or entities registered under the Lobbying Disclosure Act of 1995 have made lobbying contacts on behalf of the Disclosing Party with respect to the Matter.)

2. The Disclosing Party has not spent and will not expend any federally appropriated funds to pay any person or entity listed in Paragraph A.1. above for his or her lobbying activities or to pay any person or entity to influence or attempt to influence an officer or employee of any agency, as defined by applicable federal law, a member of Congress, an officer or employee of Congress, or an employee of a member of Congress, in connection with the award of any federally funded contract, making any federally funded grant or loan, entering into any cooperative agreement, or to extend, continue, renew, amend, or modify any federally funded contract, grant, loan, or cooperative agreement.

3. The Disclosing Party will submit an updated certification at the end of each calendar quarter in which there occurs any event that materially affects the accuracy of the statements and information set forth in paragraphs A.1. and A.2. above.

4. The Disclosing Party certifies that either: (i) it is not an organization described in section 501(c)(4) of the Internal Revenue Code of 1986; or (ii) it is an organization described in section 501(c)(4) of the Internal Revenue Code of 1986 but has not engaged and will not engage in "Lobbying Activities".

5. If the Disclosing Party is the Applicant, the Disclosing Party must obtain certifications equal in form and substance to paragraphs A.1. through A.4. above from all subcontractors before it awards any subcontract and the Disclosing Party must maintain all such subcontractors' certifications for the duration of the Matter and must make such certifications promptly available to the City upon request.

B. CERTIFICATION REGARDING EQUAL EMPLOYMENT OPPORTUNITY

If the Matter is federally funded, federal regulations require the Applicant and all proposed subcontractors to submit the following information with their bids or in writing at the outset of negotiations.

Is the Disclosing Party the Applicant?

Yes No

If "Yes," answer the three questions below:

1. Have you developed and do you have on file affirmative action programs pursuant to applicable federal regulations? (See 41 CFR Part 60-2.)

Yes No

2. Have you filed with the Joint Reporting Committee, the Director of the Office of Federal Contract Compliance Programs, or the Equal Employment Opportunity Commission all reports due under the applicable filing requirements?

Yes No

3. Have you participated in any previous contracts or subcontracts subject to the equal opportunity clause?

Yes No

If you checked "No" to question 1. or 2. above, please provide an explanation:

SECTION VII -- ACKNOWLEDGMENTS, CONTRACT INCORPORATION, COMPLIANCE, PENALTIES, DISCLOSURE

The Disclosing Party understands and agrees that:

A. The certifications, disclosures, and acknowledgments contained in this EDS will become part of any contract or other agreement between the Applicant and the City in connection with the Matter, whether procurement, City assistance, or other City action, and are material inducements to the City's execution of any contract or taking other action with respect to the Matter. The Disclosing Party understands that it must comply with all statutes, ordinances, and regulations on which this EDS is based.

B. The City's Governmental Ethics and Campaign Financing Ordinances, Chapters 2-156 and 2-164 of the Municipal Code, impose certain duties and obligations on persons or entities seeking City contracts, work, business, or transactions. The full text of these ordinances and a training program is available on line at www.cityofchicago.org/Ethics, and may also be obtained from the City's Board of Ethics, 740 N.

Sedgwick St., Suite 500, Chicago, IL 60610, (312) 744-9660. The Disclosing Party must comply fully with the applicable ordinances.

C. If the City determines that any information provided in this EDS is false, incomplete or inaccurate, any contract or other agreement in connection with which it is submitted may be rescinded or be void or voidable, and the City may pursue any remedies under the contract or agreement (if not rescinded or void), at law, or in equity, including terminating the Disclosing Party's participation in the Matter and/or declining to allow the Disclosing Party to participate in other transactions with the City. Remedies at law for a false statement of material fact may include incarceration and an award to the City of treble damages.

D. It is the City's policy to make this document available to the public on its Internet site and/or upon request. Some or all of the information provided on this EDS and any attachments to this EDS may be made available to the public on the Internet, in response to a Freedom of Information Act request, or otherwise. By completing and signing this EDS, the Disclosing Party waives and releases any possible rights or claims which it may have against the City in connection with the public release of information contained in this EDS and also authorizes the City to verify the accuracy of any information submitted in this EDS.

E. The information provided in this EDS must be kept current. In the event of changes, the Disclosing Party must supplement this EDS up to the time the City takes action on the Matter. If the Matter is a contract being handled by the City's Department of Procurement Services, the Disclosing Party must update this EDS as the contract requires. **NOTE:** With respect to Matters subject to Article I of Chapter 1-23 of the Municipal Code (imposing **PERMANENT INELIGIBILITY** for certain specified offenses), the information provided herein regarding eligibility must be kept current for a longer period, as required by Chapter 1-23 and Section 2-154-020 of the Municipal Code.

The Disclosing Party represents and warrants that:

F.1. The Disclosing Party is not delinquent in the payment of any tax administered by the Illinois Department of Revenue, nor are the Disclosing Party or its Affiliated Entities delinquent in paying any fine, fee, tax or other charge owed to the City. This includes, but is not limited to, all water charges, sewer charges, license fees, parking tickets, property taxes or sales taxes.

F.2 If the Disclosing Party is the Applicant, the Disclosing Party and its Affiliated Entities will not use, nor permit their subcontractors to use, any facility listed by the U.S. E.P.A. on the federal Excluded Parties List System ("EPLS") maintained by the U. S. General Services Administration.

F.3 If the Disclosing Party is the Applicant, the Disclosing Party will obtain from any contractors/subcontractors hired or to be hired in connection with the Matter certifications equal in form and substance to those in F.1. and F.2. above and will not, without the prior written consent of the City, use any such contractor/subcontractor that does not provide such certifications or that the Disclosing Party has reason to believe has not provided or cannot provide truthful certifications.

NOTE: If the Disclosing Party cannot certify as to any of the items in F.1., F.2. or F.3. above, an explanatory statement must be attached to this EDS.

CERTIFICATION

Under penalty of perjury, the person signing below: (1) warrants that he/she is authorized to execute this EDS and Appendix A (if applicable) on behalf of the Disclosing Party, and (2) warrants that all certifications and statements contained in this EDS and Appendix A (if applicable) are true, accurate and complete as of the date furnished to the City.

518 FULLETON, LLC
(Print or type name of Disclosing Party)

By: [Signature]
(Sign here)

TRAGO PAPPAS
(Print or type name of person signing)

PRESIDENT OF LLC MANAGER
(Print or type title of person signing)

Signed and sworn to before me on (date) 3/25/2014,
at COOK County, IL (state).

Johanna M. Romero Notary Public.

Commission expires: 4/2/2016.

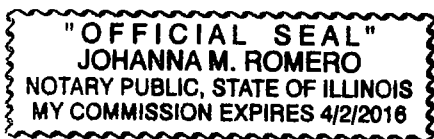

**CITY OF CHICAGO
ECONOMIC DISCLOSURE STATEMENT AND AFFIDAVIT
APPENDIX A**

FAMILIAL RELATIONSHIPS WITH ELECTED CITY OFFICIALS AND DEPARTMENT HEADS

This Appendix is to be completed only by (a) the Applicant, and (b) any legal entity which has a direct ownership interest in the Applicant exceeding 7.5 percent. It is not to be completed by any legal entity which has only an indirect ownership interest in the Applicant.

Under Municipal Code Section 2-154-015, the Disclosing Party must disclose whether such Disclosing Party or any "Applicable Party" or any Spouse or Domestic Partner thereof currently has a "familial relationship" with any elected city official or department head. A "familial relationship" exists if, as of the date this EDS is signed, the Disclosing Party or any "Applicable Party" or any Spouse or Domestic Partner thereof is related to the mayor, any alderman, the city clerk, the city treasurer or any city department head as spouse or domestic partner or as any of the following, whether by blood or adoption: parent, child, brother or sister, aunt or uncle, niece or nephew, grandparent, grandchild, father-in-law, mother-in-law, son-in-law, daughter-in-law, stepfather or stepmother, stepson or stepdaughter, stepbrother or stepsister or half-brother or half-sister.

"Applicable Party" means (1) all executive officers of the Disclosing Party listed in Section II.B.1.a., if the Disclosing Party is a corporation; all partners of the Disclosing Party, if the Disclosing Party is a general partnership; all general partners and limited partners of the Disclosing Party, if the Disclosing Party is a limited partnership; all managers, managing members and members of the Disclosing Party, if the Disclosing Party is a limited liability company; (2) all principal officers of the Disclosing Party; and (3) any person having more than a 7.5 percent ownership interest in the Disclosing Party. "Principal officers" means the president, chief operating officer, executive director, chief financial officer, treasurer or secretary of a legal entity or any person exercising similar authority.

Does the Disclosing Party or any "Applicable Party" or any Spouse or Domestic Partner thereof currently have a "familial relationship" with an elected city official or department head?

Yes

No

If yes, please identify below (1) the name and title of such person, (2) the name of the legal entity to which such person is connected; (3) the name and title of the elected city official or department head to whom such person has a familial relationship, and (4) the precise nature of such familial relationship.

**CITY OF CHICAGO
ECONOMIC DISCLOSURE STATEMENT
AND AFFIDAVIT**

SECTION I -- GENERAL INFORMATION

A. Legal name of the Disclosing Party submitting this EDS. Include d/b/a/ if applicable:

PHILIP PAPPAS IRREVOCABLE GIFT TRUST DATED 12-20-12

Check ONE of the following three boxes:

Indicate whether the Disclosing Party submitting this EDS is:

1. the Applicant

OR

2. a legal entity holding a direct or indirect interest in the Applicant. State the legal name of the Applicant in which the Disclosing Party holds an interest: 518 FULLERTON, LLC

OR

3. a legal entity with a right of control (see Section II.B.1.) State the legal name of the entity in which the Disclosing Party holds a right of control: _____

B. Business address of the Disclosing Party:

3654 N. LINCOLN

CHICAGO, IL 60613

C. Telephone: 773-435-0447 Fax: 773-472-4738 Email: tiago.pappas@gmail.com

D. Name of contact person: TIAGO PAPPAS

E. Federal Employer Identification No. (if you have one): _____

F. Brief description of contract, transaction or other undertaking (referred to below as the "Matter") to which this EDS pertains. (Include project number and location of property, if applicable):

PERMIT FEE WAIVER: 518 W. Fullerton Pkwy
BUREAU OF PLANNING AND ZONING

G. Which City agency or department is requesting this EDS? HISTORIC PRESERVATION DIVISION

If the Matter is a contract being handled by the City's Department of Procurement Services, please complete the following:

Specification # _____ and Contract # _____

SECTION II -- DISCLOSURE OF OWNERSHIP INTERESTS

A. NATURE OF THE DISCLOSING PARTY

1. Indicate the nature of the Disclosing Party:

- Person
- Publicly registered business corporation
- Privately held business corporation
- Sole proprietorship
- General partnership
- Limited partnership
- Trust
- Limited liability company
- Limited liability partnership
- Joint venture
- Not-for-profit corporation
(Is the not-for-profit corporation also a 501(c)(3))?
 Yes No
- Other (please specify)

2. For legal entities, the state (or foreign country) of incorporation or organization, if applicable:

ILLINOIS

3. For legal entities not organized in the State of Illinois: Has the organization registered to do business in the State of Illinois as a foreign entity?

- Yes No N/A

B. IF THE DISCLOSING PARTY IS A LEGAL ENTITY:

1. List below the full names and titles of all executive officers and all directors of the entity.

NOTE: For not-for-profit corporations, also list below all members, if any, which are legal entities. If there are no such members, write "no members." For trusts, estates or other similar entities, list below the legal titleholder(s).

If the entity is a general partnership, limited partnership, limited liability company, limited liability partnership or joint venture, list below the name and title of each general partner, managing member, manager or any other person or entity that controls the day-to-day management of the Disclosing Party.

NOTE: Each legal entity listed below must submit an EDS on its own behalf.

| Name | Title |
|--------------|---------|
| PHILIP PAPAS | TRUSTEE |
| | |
| | |
| | |

2. Please provide the following information concerning each person or entity having a direct or indirect beneficial interest (including ownership) in excess of 7.5% of the Disclosing Party. Examples of such an interest include shares in a corporation, partnership interest in a partnership or joint venture,

interest of a member or manager in a limited liability company, or interest of a beneficiary of a trust, estate or other similar entity. If none, state "None." NOTE: Pursuant to Section 2-154-030 of the Municipal Code of Chicago ("Municipal Code"), the City may require any such additional information from any applicant which is reasonably intended to achieve full disclosure.

| Name | Business Address | Percentage Interest in the Disclosing Party |
|---------------|-------------------------------------|---|
| PHILIP PAPPAS | 3654 N. LINCOLN, CHICAGO, IL, 60613 | 100% |
| | | |
| | | |
| | | |

SECTION III -- BUSINESS RELATIONSHIPS WITH CITY ELECTED OFFICIALS

Has the Disclosing Party had a "business relationship," as defined in Chapter 2-156 of the Municipal Code, with any City elected official in the 12 months before the date this EDS is signed?

Yes No

If yes, please identify below the name(s) of such City elected official(s) and describe such relationship(s):

SECTION IV -- DISCLOSURE OF SUBCONTRACTORS AND OTHER RETAINED PARTIES

The Disclosing Party must disclose the name and business address of each subcontractor, attorney, lobbyist, accountant, consultant and any other person or entity whom the Disclosing Party has retained or expects to retain in connection with the Matter, as well as the nature of the relationship, and the total amount of the fees paid or estimated to be paid. The Disclosing Party is not required to disclose employees who are paid solely through the Disclosing Party's regular payroll.

"Lobbyist" means any person or entity who undertakes to influence any legislative or administrative action on behalf of any person or entity other than: (1) a not-for-profit entity, on an unpaid basis, or (2) himself. "Lobbyist" also means any person or entity any part of whose duties as an employee of another includes undertaking to influence any legislative or administrative action.

If the Disclosing Party is uncertain whether a disclosure is required under this Section, the Disclosing Party must either ask the City whether disclosure is required or make the disclosure.

| Name (indicate whether retained or anticipated to be retained) | Business Address | Relationship to Disclosing Party (subcontractor, attorney, lobbyist, etc.) | Fees (indicate whether paid or estimated.) NOTE: "hourly rate" or "t.b.d." is not an acceptable response. |
|--|------------------|--|--|
|--|------------------|--|--|

none

(Add sheets if necessary)

Check here if the Disclosing Party has not retained, nor expects to retain, any such persons or entities.

SECTION V -- CERTIFICATIONS

A. COURT-ORDERED CHILD SUPPORT COMPLIANCE

Under Municipal Code Section 2-92-415, substantial owners of business entities that contract with the City must remain in compliance with their child support obligations throughout the contract's term.

Has any person who directly or indirectly owns 10% or more of the Disclosing Party been declared in arrearage on any child support obligations by any Illinois court of competent jurisdiction?

Yes No No person directly or indirectly owns 10% or more of the Disclosing Party.

If "Yes," has the person entered into a court-approved agreement for payment of all support owed and is the person in compliance with that agreement?

Yes No

B. FURTHER CERTIFICATIONS

1. Pursuant to Municipal Code Chapter 1-23, Article I ("Article I")(which the Applicant should consult for defined terms (e.g., "doing business") and legal requirements), if the Disclosing Party submitting this EDS is the Applicant and is doing business with the City, then the Disclosing Party certifies as follows: (i) neither the Applicant nor any controlling person is currently indicted or charged with, or has admitted guilt of, or has ever been convicted of, or placed under supervision for, any criminal offense involving actual, attempted, or conspiracy to commit bribery, theft, fraud, forgery, perjury, dishonesty or deceit against an officer or employee of the City or any sister agency; and (ii) the Applicant understands and acknowledges that compliance with Article I is a continuing requirement for doing business with the City. **NOTE:** If Article I applies to the Applicant, the permanent compliance timeframe in Article I supersedes some five-year compliance timeframes in certifications 2 and 3 below.

2. The Disclosing Party and, if the Disclosing Party is a legal entity, all of those persons or entities identified in Section II.B.1. of this EDS:

- a. are not presently debarred, suspended, proposed for debarment, declared ineligible or voluntarily excluded from any transactions by any federal, state or local unit of government;
- b. have not, within a five-year period preceding the date of this EDS, been convicted of a criminal offense, adjudged guilty, or had a civil judgment rendered against them in connection with: obtaining, attempting to obtain, or performing a public (federal, state or local) transaction or contract under a public transaction; a violation of federal or state antitrust statutes; fraud; embezzlement; theft; forgery; bribery; falsification or destruction of records; making false statements; or receiving stolen property;
- c. are not presently indicted for, or criminally or civilly charged by, a governmental entity (federal, state or local) with committing any of the offenses set forth in clause B.2.b. of this Section V;
- d. have not, within a five-year period preceding the date of this EDS, had one or more public transactions (federal, state or local) terminated for cause or default; and
- e. have not, within a five-year period preceding the date of this EDS, been convicted, adjudged guilty, or found liable in a civil proceeding, or in any criminal or civil action, including actions concerning environmental violations, instituted by the City or by the federal government, any state, or any other unit of local government.

3. The certifications in subparts 3, 4 and 5 concern:

- the Disclosing Party;
- any "Contractor" (meaning any contractor or subcontractor used by the Disclosing Party in connection with the Matter, including but not limited to all persons or legal entities disclosed under Section IV, "Disclosure of Subcontractors and Other Retained Parties");
- any "Affiliated Entity" (meaning a person or entity that, directly or indirectly: controls the Disclosing Party, is controlled by the Disclosing Party, or is, with the Disclosing Party, under common control of another person or entity. Indicia of control include, without limitation: interlocking management or ownership; identity of interests among family members, shared facilities and equipment; common use of employees; or organization of a business entity following the ineligibility of a business entity to do business with federal or state or local government, including the City, using substantially the same management, ownership, or principals as the ineligible entity); with respect to Contractors, the term Affiliated Entity means a person or entity that directly or indirectly controls the Contractor, is controlled by it, or, with the Contractor, is under common control of another person or entity;
- any responsible official of the Disclosing Party, any Contractor or any Affiliated Entity or any other official, agent or employee of the Disclosing Party, any Contractor or any Affiliated Entity, acting pursuant to the direction or authorization of a responsible official of the Disclosing Party, any Contractor or any Affiliated Entity (collectively "Agents").

Neither the Disclosing Party, nor any Contractor, nor any Affiliated Entity of either the Disclosing Party or any Contractor nor any Agents have, during the five years before the date this EDS is signed, or, with respect to a Contractor, an Affiliated Entity, or an Affiliated Entity of a Contractor during the five years before the date of such Contractor's or Affiliated Entity's contract or engagement in connection with the Matter:

- a. bribed or attempted to bribe, or been convicted or adjudged guilty of bribery or attempting to bribe, a public officer or employee of the City, the State of Illinois, or any agency of the federal government or of any state or local government in the United States of America, in that officer's or employee's official capacity;
- b. agreed or colluded with other bidders or prospective bidders, or been a party to any such agreement, or been convicted or adjudged guilty of agreement or collusion among bidders or prospective bidders, in restraint of freedom of competition by agreement to bid a fixed price or otherwise; or
- c. made an admission of such conduct described in a. or b. above that is a matter of record, but have not been prosecuted for such conduct; or
- d. violated the provisions of Municipal Code Section 2-92-610 (Living Wage Ordinance).

4. Neither the Disclosing Party, Affiliated Entity or Contractor, or any of their employees, officials, agents or partners, is barred from contracting with any unit of state or local government as a result of engaging in or being convicted of (1) bid-rigging in violation of 720 ILCS 5/33E-3; (2) bid-rotating in violation of 720 ILCS 5/33E-4; or (3) any similar offense of any state or of the United States of America that contains the same elements as the offense of bid-rigging or bid-rotating.

5. Neither the Disclosing Party nor any Affiliated Entity is listed on any of the following lists maintained by the Office of Foreign Assets Control of the U.S. Department of the Treasury or the Bureau of Industry and Security of the U.S. Department of Commerce or their successors: the Specially Designated Nationals List, the Denied Persons List, the Unverified List, the Entity List and the Debarred List.

6. The Disclosing Party understands and shall comply with the applicable requirements of Chapters 2-55 (Legislative Inspector General), 2-56 (Inspector General) and 2-156 (Governmental Ethics) of the Municipal Code.

7. If the Disclosing Party is unable to certify to any of the above statements in this Part B (Further Certifications), the Disclosing Party must explain below:

If the letters "NA," the word "None," or no response appears on the lines above, it will be conclusively presumed that the Disclosing Party certified to the above statements.

8. To the best of the Disclosing Party's knowledge after reasonable inquiry, the following is a complete list of all current employees of the Disclosing Party who were, at any time during the 12-month period preceding the execution date of this EDS, an employee, or elected or appointed official, of the City of Chicago (if none, indicate with "N/A" or "none").

NONE

9. To the best of the Disclosing Party's knowledge after reasonable inquiry, the following is a complete list of all gifts that the Disclosing Party has given or caused to be given, at any time during the 12-month period preceding the execution date of this EDS, to an employee, or elected or appointed official, of the City of Chicago. For purposes of this statement, a "gift" does not include: (i) anything made generally available to City employees or to the general public, or (ii) food or drink provided in the course of official City business and having a retail value of less than \$20 per recipient (if none, indicate with "N/A" or "none"). As to any gift listed below, please also list the name of the City recipient.

NONE

C. CERTIFICATION OF STATUS AS FINANCIAL INSTITUTION

1. The Disclosing Party certifies that the Disclosing Party (check one)

is is not

a "financial institution" as defined in Section 2-32-455(b) of the Municipal Code.

2. If the Disclosing Party IS a financial institution, then the Disclosing Party pledges:

"We are not and will not become a predatory lender as defined in Chapter 2-32 of the Municipal Code. We further pledge that none of our affiliates is, and none of them will become, a predatory lender as defined in Chapter 2-32 of the Municipal Code. We understand that becoming a predatory lender or becoming an affiliate of a predatory lender may result in the loss of the privilege of doing business with the City."

If the Disclosing Party is unable to make this pledge because it or any of its affiliates (as defined in Section 2-32-455(b) of the Municipal Code) is a predatory lender within the meaning of Chapter 2-32 of the Municipal Code, explain here (attach additional pages if necessary):

If the letters "NA," the word "None," or no response appears on the lines above, it will be conclusively presumed that the Disclosing Party certified to the above statements.

D. CERTIFICATION REGARDING INTEREST IN CITY BUSINESS

Any words or terms that are defined in Chapter 2-156 of the Municipal Code have the same meanings when used in this Part D.

1. In accordance with Section 2-156-110 of the Municipal Code: Does any official or employee of the City have a financial interest in his or her own name or in the name of any other person or entity in the Matter?

Yes No

NOTE: If you checked "Yes" to Item D.1., proceed to Items D.2. and D.3. If you checked "No" to Item D.1., proceed to Part E.

2. Unless sold pursuant to a process of competitive bidding, or otherwise permitted, no City elected official or employee shall have a financial interest in his or her own name or in the name of any other person or entity in the purchase of any property that (i) belongs to the City, or (ii) is sold for taxes or assessments, or (iii) is sold by virtue of legal process at the suit of the City (collectively, "City Property Sale"). Compensation for property taken pursuant to the City's eminent domain power does not constitute a financial interest within the meaning of this Part D.

Does the Matter involve a City Property Sale?

Yes No

3. If you checked "Yes" to Item D.1., provide the names and business addresses of the City officials or employees having such interest and identify the nature of such interest:

| Name | Business Address | Nature of Interest |
|-------|------------------|--------------------|
| <hr/> | | |
| <hr/> | | |
| <hr/> | | |

4. The Disclosing Party further certifies that no prohibited financial interest in the Matter will be acquired by any City official or employee.

E. CERTIFICATION REGARDING SLAVERY ERA BUSINESS

Please check either 1. or 2. below. If the Disclosing Party checks 2., the Disclosing Party must disclose below or in an attachment to this EDS all information required by paragraph 2. Failure to

comply with these disclosure requirements may make any contract entered into with the City in connection with the Matter voidable by the City.

✓ 1. The Disclosing Party verifies that the Disclosing Party has searched any and all records of the Disclosing Party and any and all predecessor entities regarding records of investments or profits from slavery or slaveholder insurance policies during the slavery era (including insurance policies issued to slaveholders that provided coverage for damage to or injury or death of their slaves), and the Disclosing Party has found no such records.

2. The Disclosing Party verifies that, as a result of conducting the search in step 1 above, the Disclosing Party has found records of investments or profits from slavery or slaveholder insurance policies. The Disclosing Party verifies that the following constitutes full disclosure of all such records, including the names of any and all slaves or slaveholders described in those records:

SECTION VI -- CERTIFICATIONS FOR FEDERALLY FUNDED MATTERS

NOTE: If the Matter is federally funded, complete this Section VI. **If the Matter is not federally funded**, proceed to Section VII. For purposes of this Section VI, tax credits allocated by the City and proceeds of debt obligations of the City are not federal funding.

A. CERTIFICATION REGARDING LOBBYING

1. List below the names of all persons or entities registered under the federal Lobbying Disclosure Act of 1995 who have made lobbying contacts on behalf of the Disclosing Party with respect to the Matter: (Add sheets if necessary):

(If no explanation appears or begins on the lines above, or if the letters "NA" or if the word "None" appear, it will be conclusively presumed that the Disclosing Party means that NO persons or entities registered under the Lobbying Disclosure Act of 1995 have made lobbying contacts on behalf of the Disclosing Party with respect to the Matter.)

2. The Disclosing Party has not spent and will not expend any federally appropriated funds to pay any person or entity listed in Paragraph A.1. above for his or her lobbying activities or to pay any person or entity to influence or attempt to influence an officer or employee of any agency, as defined by applicable federal law, a member of Congress, an officer or employee of Congress, or an employee of a member of Congress, in connection with the award of any federally funded contract, making any federally funded grant or loan, entering into any cooperative agreement, or to extend, continue, renew, amend, or modify any federally funded contract, grant, loan, or cooperative agreement.

3. The Disclosing Party will submit an updated certification at the end of each calendar quarter in which there occurs any event that materially affects the accuracy of the statements and information set forth in paragraphs A.1. and A.2. above.

4. The Disclosing Party certifies that either: (i) it is not an organization described in section 501(c)(4) of the Internal Revenue Code of 1986; or (ii) it is an organization described in section 501(c)(4) of the Internal Revenue Code of 1986 but has not engaged and will not engage in "Lobbying Activities".

5. If the Disclosing Party is the Applicant, the Disclosing Party must obtain certifications equal in form and substance to paragraphs A.1. through A.4. above from all subcontractors before it awards any subcontract and the Disclosing Party must maintain all such subcontractors' certifications for the duration of the Matter and must make such certifications promptly available to the City upon request.

B. CERTIFICATION REGARDING EQUAL EMPLOYMENT OPPORTUNITY

If the Matter is federally funded, federal regulations require the Applicant and all proposed subcontractors to submit the following information with their bids or in writing at the outset of negotiations.

Is the Disclosing Party the Applicant?

Yes No

If "Yes," answer the three questions below:

1. Have you developed and do you have on file affirmative action programs pursuant to applicable federal regulations? (See 41 CFR Part 60-2.)

Yes No

2. Have you filed with the Joint Reporting Committee, the Director of the Office of Federal Contract Compliance Programs, or the Equal Employment Opportunity Commission all reports due under the applicable filing requirements?

Yes No

3. Have you participated in any previous contracts or subcontracts subject to the equal opportunity clause?

Yes No

If you checked "No" to question 1. or 2. above, please provide an explanation:

SECTION VII -- ACKNOWLEDGMENTS, CONTRACT INCORPORATION, COMPLIANCE, PENALTIES, DISCLOSURE

The Disclosing Party understands and agrees that:

A. The certifications, disclosures, and acknowledgments contained in this EDS will become part of any contract or other agreement between the Applicant and the City in connection with the Matter, whether procurement, City assistance, or other City action, and are material inducements to the City's execution of any contract or taking other action with respect to the Matter. The Disclosing Party understands that it must comply with all statutes, ordinances, and regulations on which this EDS is based.

B. The City's Governmental Ethics and Campaign Financing Ordinances, Chapters 2-156 and 2-164 of the Municipal Code, impose certain duties and obligations on persons or entities seeking City contracts, work, business, or transactions. The full text of these ordinances and a training program is available on line at www.cityofchicago.org/Ethics, and may also be obtained from the City's Board of Ethics, 740 N.

Sedgwick St., Suite 500, Chicago, IL 60610, (312) 744-9660. The Disclosing Party must comply fully with the applicable ordinances.

C. If the City determines that any information provided in this EDS is false, incomplete or inaccurate, any contract or other agreement in connection with which it is submitted may be rescinded or be void or voidable, and the City may pursue any remedies under the contract or agreement (if not rescinded or void), at law, or in equity, including terminating the Disclosing Party's participation in the Matter and/or declining to allow the Disclosing Party to participate in other transactions with the City. Remedies at law for a false statement of material fact may include incarceration and an award to the City of treble damages.

D. It is the City's policy to make this document available to the public on its Internet site and/or upon request. Some or all of the information provided on this EDS and any attachments to this EDS may be made available to the public on the Internet, in response to a Freedom of Information Act request, or otherwise. By completing and signing this EDS, the Disclosing Party waives and releases any possible rights or claims which it may have against the City in connection with the public release of information contained in this EDS and also authorizes the City to verify the accuracy of any information submitted in this EDS.

E. The information provided in this EDS must be kept current. In the event of changes, the Disclosing Party must supplement this EDS up to the time the City takes action on the Matter. If the Matter is a contract being handled by the City's Department of Procurement Services, the Disclosing Party must update this EDS as the contract requires. **NOTE:** With respect to Matters subject to Article I of Chapter 1-23 of the Municipal Code (imposing **PERMANENT INELIGIBILITY** for certain specified offenses), the information provided herein regarding eligibility must be kept current for a longer period, as required by Chapter 1-23 and Section 2-154-020 of the Municipal Code.

The Disclosing Party represents and warrants that:

F.1. The Disclosing Party is not delinquent in the payment of any tax administered by the Illinois Department of Revenue, nor are the Disclosing Party or its Affiliated Entities delinquent in paying any fine, fee, tax or other charge owed to the City. This includes, but is not limited to, all water charges, sewer charges, license fees, parking tickets, property taxes or sales taxes.

F.2 If the Disclosing Party is the Applicant, the Disclosing Party and its Affiliated Entities will not use, nor permit their subcontractors to use, any facility listed by the U.S. E.P.A. on the federal Excluded Parties List System ("EPLS") maintained by the U. S. General Services Administration.

F.3 If the Disclosing Party is the Applicant, the Disclosing Party will obtain from any contractors/subcontractors hired or to be hired in connection with the Matter certifications equal in form and substance to those in F.1. and F.2. above and will not, without the prior written consent of the City, use any such contractor/subcontractor that does not provide such certifications or that the Disclosing Party has reason to believe has not provided or cannot provide truthful certifications.

NOTE: If the Disclosing Party cannot certify as to any of the items in F.1., F.2. or F.3. above, an explanatory statement must be attached to this EDS.

CERTIFICATION

Under penalty of perjury, the person signing below: (1) warrants that he/she is authorized to execute this EDS and Appendix A (if applicable) on behalf of the Disclosing Party, and (2) warrants that all certifications and statements contained in this EDS and Appendix A (if applicable) are true, accurate and complete as of the date furnished to the City.

PHILIP PARRAS (REVOLVABLE GIFT TRUST DATED 12-20-12)
(Print or type name of Disclosing Party)

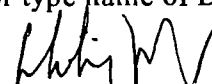
By: 
(Sign here)

PHILIP PARRAS
(Print or type name of person signing)

TRUSTEE
(Print or type title of person signing)

Signed and sworn to before me on (date) 3/25/2014,
at COOK County, IL (state).

Johanna M. Romero Notary Public.

Commission expires: 4/2/2016.

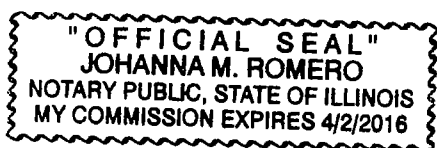

**CITY OF CHICAGO
ECONOMIC DISCLOSURE STATEMENT AND AFFIDAVIT
APPENDIX A**

FAMILIAL RELATIONSHIPS WITH ELECTED CITY OFFICIALS AND DEPARTMENT HEADS

This Appendix is to be completed only by (a) the Applicant, and (b) any legal entity which has a direct ownership interest in the Applicant exceeding 7.5 percent. It is not to be completed by any legal entity which has only an indirect ownership interest in the Applicant.

Under Municipal Code Section 2-154-015, the Disclosing Party must disclose whether such Disclosing Party or any “Applicable Party” or any Spouse or Domestic Partner thereof currently has a “familial relationship” with any elected city official or department head. A “familial relationship” exists if, as of the date this EDS is signed, the Disclosing Party or any “Applicable Party” or any Spouse or Domestic Partner thereof is related to the mayor, any alderman, the city clerk, the city treasurer or any city department head as spouse or domestic partner or as any of the following, whether by blood or adoption: parent, child, brother or sister, aunt or uncle, niece or nephew, grandparent, grandchild, father-in-law, mother-in-law, son-in-law, daughter-in-law, stepfather or stepmother, stepson or stepdaughter, stepbrother or stepsister or half-brother or half-sister.

“Applicable Party” means (1) all executive officers of the Disclosing Party listed in Section II.B.1.a., if the Disclosing Party is a corporation; all partners of the Disclosing Party, if the Disclosing Party is a general partnership; all general partners and limited partners of the Disclosing Party, if the Disclosing Party is a limited partnership; all managers, managing members and members of the Disclosing Party, if the Disclosing Party is a limited liability company; (2) all principal officers of the Disclosing Party; and (3) any person having more than a 7.5 percent ownership interest in the Disclosing Party. “Principal officers” means the president, chief operating officer, executive director, chief financial officer, treasurer or secretary of a legal entity or any person exercising similar authority.

Does the Disclosing Party or any “Applicable Party” or any Spouse or Domestic Partner thereof currently have a “familial relationship” with an elected city official or department head?

Yes No

If yes, please identify below (1) the name and title of such person, (2) the name of the legal entity to which such person is connected; (3) the name and title of the elected city official or department head to whom such person has a familial relationship, and (4) the precise nature of such familial relationship.

**CITY OF CHICAGO
ECONOMIC DISCLOSURE STATEMENT
AND AFFIDAVIT**

SECTION I -- GENERAL INFORMATION

A. Legal name of the Disclosing Party submitting this EDS. Include d/b/a/ if applicable:

ANA LUCIA SANT'ANNA PAPPAS IRREVOCABLE GIFT TRUST

DATED 12-8-12

Check ONE of the following three boxes:

Indicate whether the Disclosing Party submitting this EDS is:

1. the Applicant

OR

2. a legal entity holding a direct or indirect interest in the Applicant. State the legal name of the Applicant in which the Disclosing Party holds an interest: STB FULLERTON, LLC

OR

3. a legal entity with a right of control (see Section II.B.1.) State the legal name of the entity in which the Disclosing Party holds a right of control: _____

B. Business address of the Disclosing Party:

3654 N. LINCOLN

CHICAGO, IL 60613

C. Telephone: 773-435-0447 Fax: 773-472-4738 Email: tiago.pappas@gmail.com

D. Name of contact person: TIAGO PAPPAS

E. Federal Employer Identification No. (if you have one): _____

F. Brief description of contract, transaction or other undertaking (referred to below as the "Matter") to which this EDS pertains. (Include project number and location of property, if applicable):

PERMIT FEE WAIVER: 518 W. Fullerton Pkwy

DEPARTMENT OF PLANNING AND ZONING

G. Which City agency or department is requesting this EDS? HISTORIC PRESERVATION DIVISION

If the Matter is a contract being handled by the City's Department of Procurement Services, please complete the following:

Specification # _____ and Contract # _____

SECTION II -- DISCLOSURE OF OWNERSHIP INTERESTS

A. NATURE OF THE DISCLOSING PARTY

1. Indicate the nature of the Disclosing Party:
- | | |
|---|--|
| <input type="checkbox"/> Person | <input type="checkbox"/> Limited liability company |
| <input type="checkbox"/> Publicly registered business corporation | <input type="checkbox"/> Limited liability partnership |
| <input type="checkbox"/> Privately held business corporation | <input type="checkbox"/> Joint venture |
| <input type="checkbox"/> Sole proprietorship | <input type="checkbox"/> Not-for-profit corporation |
| <input type="checkbox"/> General partnership | (Is the not-for-profit corporation also a 501(c)(3))? |
| <input type="checkbox"/> Limited partnership | <input type="checkbox"/> Yes <input type="checkbox"/> No |
| <input checked="" type="checkbox"/> Trust | <input type="checkbox"/> Other (please specify) |

2. For legal entities, the state (or foreign country) of incorporation or organization, if applicable:

ILLINOIS

3. For legal entities not organized in the State of Illinois: Has the organization registered to do business in the State of Illinois as a foreign entity?

- Yes No N/A

B. IF THE DISCLOSING PARTY IS A LEGAL ENTITY:

1. List below the full names and titles of all executive officers and all directors of the entity. **NOTE:** For not-for-profit corporations, also list below all members, if any, which are legal entities. If there are no such members, write "no members." For trusts, estates or other similar entities, list below the legal titleholder(s).

If the entity is a general partnership, limited partnership, limited liability company, limited liability partnership or joint venture, list below the name and title of each general partner, managing member, manager or any other person or entity that controls the day-to-day management of the Disclosing Party. **NOTE:** Each legal entity listed below must submit an EDS on its own behalf.

| Name | Title |
|-----------------------------------|----------------|
| <u>ANNA LYNN SANT'ANNA PAPPAS</u> | <u>TRUSTEE</u> |
| | |
| | |
| | |

2. Please provide the following information concerning each person or entity having a direct or indirect beneficial interest (including ownership) in excess of 7.5% of the Disclosing Party. Examples of such an interest include shares in a corporation, partnership interest in a partnership or joint venture,

interest of a member or manager in a limited liability company, or interest of a beneficiary of a trust, estate or other similar entity. If none, state "None." NOTE: Pursuant to Section 2-154-030 of the Municipal Code of Chicago ("Municipal Code"), the City may require any such additional information from any applicant which is reasonably intended to achieve full disclosure.

| Name | Business Address | Percentage Interest in the Disclosing Party |
|---------------------------|----------------------------------|---|
| ANALUCIA SANT'ANNA PAPPAS | 3654 N. LINCOLN, CHI., IL, 60613 | 100% |
| | | |
| | | |

SECTION III -- BUSINESS RELATIONSHIPS WITH CITY ELECTED OFFICIALS

Has the Disclosing Party had a "business relationship," as defined in Chapter 2-156 of the Municipal Code, with any City elected official in the 12 months before the date this EDS is signed?

Yes

No

If yes, please identify below the name(s) of such City elected official(s) and describe such relationship(s):

SECTION IV -- DISCLOSURE OF SUBCONTRACTORS AND OTHER RETAINED PARTIES

The Disclosing Party must disclose the name and business address of each subcontractor, attorney, lobbyist, accountant, consultant and any other person or entity whom the Disclosing Party has retained or expects to retain in connection with the Matter, as well as the nature of the relationship, and the total amount of the fees paid or estimated to be paid. The Disclosing Party is not required to disclose employees who are paid solely through the Disclosing Party's regular payroll.

"Lobbyist" means any person or entity who undertakes to influence any legislative or administrative action on behalf of any person or entity other than: (1) a not-for-profit entity, on an unpaid basis, or (2) himself. "Lobbyist" also means any person or entity any part of whose duties as an employee of another includes undertaking to influence any legislative or administrative action.

If the Disclosing Party is uncertain whether a disclosure is required under this Section, the Disclosing Party must either ask the City whether disclosure is required or make the disclosure.

| Name (indicate whether retained or anticipated to be retained) | Business Address | Relationship to Disclosing Party (subcontractor, attorney, lobbyist, etc.) | Fees (indicate whether paid or estimated.) NOTE: "hourly rate" or "t.b.d." is not an acceptable response. |
|--|------------------|--|--|
|--|------------------|--|--|

none

(Add sheets if necessary)

Check here if the Disclosing Party has not retained, nor expects to retain, any such persons or entities.

SECTION V -- CERTIFICATIONS

A. COURT-ORDERED CHILD SUPPORT COMPLIANCE

Under Municipal Code Section 2-92-415, substantial owners of business entities that contract with the City must remain in compliance with their child support obligations throughout the contract's term.

Has any person who directly or indirectly owns 10% or more of the Disclosing Party been declared in arrearage on any child support obligations by any Illinois court of competent jurisdiction?

Yes No No person directly or indirectly owns 10% or more of the Disclosing Party.

If "Yes," has the person entered into a court-approved agreement for payment of all support owed and is the person in compliance with that agreement?

Yes No

B. FURTHER CERTIFICATIONS

1. Pursuant to Municipal Code Chapter 1-23, Article I ("Article I")(which the Applicant should consult for defined terms (e.g., "doing business") and legal requirements), if the Disclosing Party submitting this EDS is the Applicant and is doing business with the City, then the Disclosing Party certifies as follows: (i) neither the Applicant nor any controlling person is currently indicted or charged with, or has admitted guilt of, or has ever been convicted of, or placed under supervision for, any criminal offense involving actual, attempted, or conspiracy to commit bribery, theft, fraud, forgery, perjury, dishonesty or deceit against an officer or employee of the City or any sister agency; and (ii) the Applicant understands and acknowledges that compliance with Article I is a continuing requirement for doing business with the City. **NOTE:** If Article I applies to the Applicant, the permanent compliance timeframe in Article I supersedes some five-year compliance timeframes in certifications 2 and 3 below.

2. The Disclosing Party and, if the Disclosing Party is a legal entity, all of those persons or entities identified in Section II.B.1. of this EDS:

- a. are not presently debarred, suspended, proposed for debarment, declared ineligible or voluntarily excluded from any transactions by any federal, state or local unit of government;
- b. have not, within a five-year period preceding the date of this EDS, been convicted of a criminal offense, adjudged guilty, or had a civil judgment rendered against them in connection with: obtaining, attempting to obtain, or performing a public (federal, state or local) transaction or contract under a public transaction; a violation of federal or state antitrust statutes; fraud; embezzlement; theft; forgery; bribery; falsification or destruction of records; making false statements; or receiving stolen property;
- c. are not presently indicted for, or criminally or civilly charged by, a governmental entity (federal, state or local) with committing any of the offenses set forth in clause B.2.b. of this Section V;
- d. have not, within a five-year period preceding the date of this EDS, had one or more public transactions (federal, state or local) terminated for cause or default; and
- e. have not, within a five-year period preceding the date of this EDS, been convicted, adjudged guilty, or found liable in a civil proceeding, or in any criminal or civil action, including actions concerning environmental violations, instituted by the City or by the federal government, any state, or any other unit of local government.

3. The certifications in subparts 3, 4 and 5 concern:

- the Disclosing Party;
- any "Contractor" (meaning any contractor or subcontractor used by the Disclosing Party in connection with the Matter, including but not limited to all persons or legal entities disclosed under Section IV, "Disclosure of Subcontractors and Other Retained Parties");
- any "Affiliated Entity" (meaning a person or entity that, directly or indirectly: controls the Disclosing Party, is controlled by the Disclosing Party, or is, with the Disclosing Party, under common control of another person or entity. Indicia of control include, without limitation: interlocking management or ownership; identity of interests among family members, shared facilities and equipment; common use of employees; or organization of a business entity following the ineligibility of a business entity to do business with federal or state or local government, including the City, using substantially the same management, ownership, or principals as the ineligible entity); with respect to Contractors, the term Affiliated Entity means a person or entity that directly or indirectly controls the Contractor, is controlled by it, or, with the Contractor, is under common control of another person or entity;
- any responsible official of the Disclosing Party, any Contractor or any Affiliated Entity or any other official, agent or employee of the Disclosing Party, any Contractor or any Affiliated Entity, acting pursuant to the direction or authorization of a responsible official of the Disclosing Party, any Contractor or any Affiliated Entity (collectively "Agents").

Neither the Disclosing Party, nor any Contractor, nor any Affiliated Entity of either the Disclosing Party or any Contractor nor any Agents have, during the five years before the date this EDS is signed, or, with respect to a Contractor, an Affiliated Entity, or an Affiliated Entity of a Contractor during the five years before the date of such Contractor's or Affiliated Entity's contract or engagement in connection with the Matter:

- a. bribed or attempted to bribe, or been convicted or adjudged guilty of bribery or attempting to bribe, a public officer or employee of the City, the State of Illinois, or any agency of the federal government or of any state or local government in the United States of America, in that officer's or employee's official capacity;
- b. agreed or colluded with other bidders or prospective bidders, or been a party to any such agreement, or been convicted or adjudged guilty of agreement or collusion among bidders or prospective bidders, in restraint of freedom of competition by agreement to bid a fixed price or otherwise; or
- c. made an admission of such conduct described in a. or b. above that is a matter of record, but have not been prosecuted for such conduct; or
- d. violated the provisions of Municipal Code Section 2-92-610 (Living Wage Ordinance).

4. Neither the Disclosing Party, Affiliated Entity or Contractor, or any of their employees, officials, agents or partners, is barred from contracting with any unit of state or local government as a result of engaging in or being convicted of (1) bid-rigging in violation of 720 ILCS 5/33E-3; (2) bid-rotating in violation of 720 ILCS 5/33E-4; or (3) any similar offense of any state or of the United States of America that contains the same elements as the offense of bid-rigging or bid-rotating.

5. Neither the Disclosing Party nor any Affiliated Entity is listed on any of the following lists maintained by the Office of Foreign Assets Control of the U.S. Department of the Treasury or the Bureau of Industry and Security of the U.S. Department of Commerce or their successors: the Specially Designated Nationals List, the Denied Persons List, the Unverified List, the Entity List and the Debarred List.

6. The Disclosing Party understands and shall comply with the applicable requirements of Chapters 2-55 (Legislative Inspector General), 2-56 (Inspector General) and 2-156 (Governmental Ethics) of the Municipal Code.

7. If the Disclosing Party is unable to certify to any of the above statements in this Part B (Further Certifications), the Disclosing Party must explain below:

If the letters "NA," the word "None," or no response appears on the lines above, it will be conclusively presumed that the Disclosing Party certified to the above statements.

8. To the best of the Disclosing Party's knowledge after reasonable inquiry, the following is a complete list of all current employees of the Disclosing Party who were, at any time during the 12-month period preceding the execution date of this EDS, an employee, or elected or appointed official, of the City of Chicago (if none, indicate with "N/A" or "none").

none

9. To the best of the Disclosing Party's knowledge after reasonable inquiry, the following is a complete list of all gifts that the Disclosing Party has given or caused to be given, at any time during the 12-month period preceding the execution date of this EDS, to an employee, or elected or appointed official, of the City of Chicago. For purposes of this statement, a "gift" does not include: (i) anything made generally available to City employees or to the general public, or (ii) food or drink provided in the course of official City business and having a retail value of less than \$20 per recipient (if none, indicate with "N/A" or "none"). As to any gift listed below, please also list the name of the City recipient.

none

C. CERTIFICATION OF STATUS AS FINANCIAL INSTITUTION

1. The Disclosing Party certifies that the Disclosing Party (check one)

is is not

a "financial institution" as defined in Section 2-32-455(b) of the Municipal Code.

2. If the Disclosing Party IS a financial institution, then the Disclosing Party pledges:

"We are not and will not become a predatory lender as defined in Chapter 2-32 of the Municipal Code. We further pledge that none of our affiliates is, and none of them will become, a predatory lender as defined in Chapter 2-32 of the Municipal Code. We understand that becoming a predatory lender or becoming an affiliate of a predatory lender may result in the loss of the privilege of doing business with the City."

If the Disclosing Party is unable to make this pledge because it or any of its affiliates (as defined in Section 2-32-455(b) of the Municipal Code) is a predatory lender within the meaning of Chapter 2-32 of the Municipal Code, explain here (attach additional pages if necessary):

If the letters "NA," the word "None," or no response appears on the lines above, it will be conclusively presumed that the Disclosing Party certified to the above statements.

D. CERTIFICATION REGARDING INTEREST IN CITY BUSINESS

Any words or terms that are defined in Chapter 2-156 of the Municipal Code have the same meanings when used in this Part D.

1. In accordance with Section 2-156-110 of the Municipal Code: Does any official or employee of the City have a financial interest in his or her own name or in the name of any other person or entity in the Matter?

Yes

No

NOTE: If you checked "Yes" to Item D.1., proceed to Items D.2. and D.3. If you checked "No" to Item D.1., proceed to Part E.

2. Unless sold pursuant to a process of competitive bidding, or otherwise permitted, no City elected official or employee shall have a financial interest in his or her own name or in the name of any other person or entity in the purchase of any property that (i) belongs to the City, or (ii) is sold for taxes or assessments, or (iii) is sold by virtue of legal process at the suit of the City (collectively, "City Property Sale"). Compensation for property taken pursuant to the City's eminent domain power does not constitute a financial interest within the meaning of this Part D.

Does the Matter involve a City Property Sale?

Yes

No

3. If you checked "Yes" to Item D.1., provide the names and business addresses of the City officials or employees having such interest and identify the nature of such interest:

Name

Business Address

Nature of Interest

4. The Disclosing Party further certifies that no prohibited financial interest in the Matter will be acquired by any City official or employee.

E. CERTIFICATION REGARDING SLAVERY ERA BUSINESS

Please check either 1. or 2. below. If the Disclosing Party checks 2., the Disclosing Party must disclose below or in an attachment to this EDS all information required by paragraph 2. Failure to

comply with these disclosure requirements may make any contract entered into with the City in connection with the Matter voidable by the City.

✓ 1. The Disclosing Party verifies that the Disclosing Party has searched any and all records of the Disclosing Party and any and all predecessor entities regarding records of investments or profits from slavery or slaveholder insurance policies during the slavery era (including insurance policies issued to slaveholders that provided coverage for damage to or injury or death of their slaves), and the Disclosing Party has found no such records.

2. The Disclosing Party verifies that, as a result of conducting the search in step 1 above, the Disclosing Party has found records of investments or profits from slavery or slaveholder insurance policies. The Disclosing Party verifies that the following constitutes full disclosure of all such records, including the names of any and all slaves or slaveholders described in those records:

SECTION VI -- CERTIFICATIONS FOR FEDERALLY FUNDED MATTERS

NOTE: If the Matter is federally funded, complete this Section VI. If the Matter is not federally funded, proceed to Section VII. For purposes of this Section VI, tax credits allocated by the City and proceeds of debt obligations of the City are not federal funding.

A. CERTIFICATION REGARDING LOBBYING

1. List below the names of all persons or entities registered under the federal Lobbying Disclosure Act of 1995 who have made lobbying contacts on behalf of the Disclosing Party with respect to the Matter: (Add sheets if necessary):

(If no explanation appears or begins on the lines above, or if the letters "NA" or if the word "None" appear, it will be conclusively presumed that the Disclosing Party means that NO persons or entities registered under the Lobbying Disclosure Act of 1995 have made lobbying contacts on behalf of the Disclosing Party with respect to the Matter.)

2. The Disclosing Party has not spent and will not expend any federally appropriated funds to pay any person or entity listed in Paragraph A.1. above for his or her lobbying activities or to pay any person or entity to influence or attempt to influence an officer or employee of any agency, as defined by applicable federal law, a member of Congress, an officer or employee of Congress, or an employee of a member of Congress, in connection with the award of any federally funded contract, making any federally funded grant or loan, entering into any cooperative agreement, or to extend, continue, renew, amend, or modify any federally funded contract, grant, loan, or cooperative agreement.

3. The Disclosing Party will submit an updated certification at the end of each calendar quarter in which there occurs any event that materially affects the accuracy of the statements and information set forth in paragraphs A.1. and A.2. above.

4. The Disclosing Party certifies that either: (i) it is not an organization described in section 501(c)(4) of the Internal Revenue Code of 1986; or (ii) it is an organization described in section 501(c)(4) of the Internal Revenue Code of 1986 but has not engaged and will not engage in "Lobbying Activities".

5. If the Disclosing Party is the Applicant, the Disclosing Party must obtain certifications equal in form and substance to paragraphs A.1. through A.4. above from all subcontractors before it awards any subcontract and the Disclosing Party must maintain all such subcontractors' certifications for the duration of the Matter and must make such certifications promptly available to the City upon request.

B. CERTIFICATION REGARDING EQUAL EMPLOYMENT OPPORTUNITY

If the Matter is federally funded, federal regulations require the Applicant and all proposed subcontractors to submit the following information with their bids or in writing at the outset of negotiations.

Is the Disclosing Party the Applicant?

Yes No

If "Yes," answer the three questions below:

1. Have you developed and do you have on file affirmative action programs pursuant to applicable federal regulations? (See 41 CFR Part 60-2.)

Yes No

2. Have you filed with the Joint Reporting Committee, the Director of the Office of Federal Contract Compliance Programs, or the Equal Employment Opportunity Commission all reports due under the applicable filing requirements?

Yes No

3. Have you participated in any previous contracts or subcontracts subject to the equal opportunity clause?

Yes No

If you checked "No" to question 1. or 2. above, please provide an explanation:

SECTION VII -- ACKNOWLEDGMENTS, CONTRACT INCORPORATION, COMPLIANCE, PENALTIES, DISCLOSURE

The Disclosing Party understands and agrees that:

A. The certifications, disclosures, and acknowledgments contained in this EDS will become part of any contract or other agreement between the Applicant and the City in connection with the Matter, whether procurement, City assistance, or other City action, and are material inducements to the City's execution of any contract or taking other action with respect to the Matter. The Disclosing Party understands that it must comply with all statutes, ordinances, and regulations on which this EDS is based.

B. The City's Governmental Ethics and Campaign Financing Ordinances, Chapters 2-156 and 2-164 of the Municipal Code, impose certain duties and obligations on persons or entities seeking City contracts, work, business, or transactions. The full text of these ordinances and a training program is available on line at www.cityofchicago.org/Ethics, and may also be obtained from the City's Board of Ethics, 740 N.

Sedgwick St., Suite 500, Chicago, IL 60610, (312) 744-9660. The Disclosing Party must comply fully with the applicable ordinances.

C. If the City determines that any information provided in this EDS is false, incomplete or inaccurate, any contract or other agreement in connection with which it is submitted may be rescinded or be void or voidable, and the City may pursue any remedies under the contract or agreement (if not rescinded or void), at law, or in equity, including terminating the Disclosing Party's participation in the Matter and/or declining to allow the Disclosing Party to participate in other transactions with the City. Remedies at law for a false statement of material fact may include incarceration and an award to the City of treble damages.

D. It is the City's policy to make this document available to the public on its Internet site and/or upon request. Some or all of the information provided on this EDS and any attachments to this EDS may be made available to the public on the Internet, in response to a Freedom of Information Act request, or otherwise. By completing and signing this EDS, the Disclosing Party waives and releases any possible rights or claims which it may have against the City in connection with the public release of information contained in this EDS and also authorizes the City to verify the accuracy of any information submitted in this EDS.

E. The information provided in this EDS must be kept current. In the event of changes, the Disclosing Party must supplement this EDS up to the time the City takes action on the Matter. If the Matter is a contract being handled by the City's Department of Procurement Services, the Disclosing Party must update this EDS as the contract requires. **NOTE:** With respect to Matters subject to Article I of Chapter 1-23 of the Municipal Code (imposing **PERMANENT INELIGIBILITY** for certain specified offenses), the information provided herein regarding eligibility must be kept current for a longer period, as required by Chapter 1-23 and Section 2-154-020 of the Municipal Code.

The Disclosing Party represents and warrants that:

F.1. The Disclosing Party is not delinquent in the payment of any tax administered by the Illinois Department of Revenue, nor are the Disclosing Party or its Affiliated Entities delinquent in paying any fine, fee, tax or other charge owed to the City. This includes, but is not limited to, all water charges, sewer charges, license fees, parking tickets, property taxes or sales taxes.

F.2. If the Disclosing Party is the Applicant, the Disclosing Party and its Affiliated Entities will not use, nor permit their subcontractors to use, any facility listed by the U.S. E.P.A. on the federal Excluded Parties List System ("EPLS") maintained by the U. S. General Services Administration.

F.3. If the Disclosing Party is the Applicant, the Disclosing Party will obtain from any contractors/subcontractors hired or to be hired in connection with the Matter certifications equal in form and substance to those in F.1. and F.2. above and will not, without the prior written consent of the City, use any such contractor/subcontractor that does not provide such certifications or that the Disclosing Party has reason to believe has not provided or cannot provide truthful certifications.

NOTE: If the Disclosing Party cannot certify as to any of the items in F.1., F.2. or F.3. above, an explanatory statement must be attached to this EDS.

CERTIFICATION

Under penalty of perjury, the person signing below: (1) warrants that he/she is authorized to execute this EDS and Appendix A (if applicable) on behalf of the Disclosing Party, and (2) warrants that all certifications and statements contained in this EDS and Appendix A (if applicable) are true, accurate and complete as of the date furnished to the City.

ANA LUCIA SANT'ANNA PAPPAS IRREVOCABLE GIFT TRUST DATED 12-8-12
(Print or type name of Disclosing Party)

By: *[Signature]*
(Sign here)

ANA LUCIA SANT'ANNA PAPPAS
(Print or type name of person signing)

TRUSTEE
(Print or type title of person signing)

Signed and sworn to before me on (date) 3/25/2014,
at COOK County, IL (state).

Johanna M. Romero Notary Public.

Commission expires: 4/2/2016.

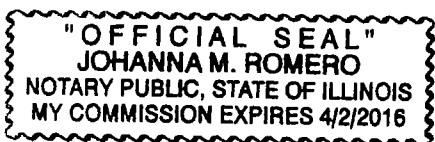

**CITY OF CHICAGO
ECONOMIC DISCLOSURE STATEMENT AND AFFIDAVIT
APPENDIX A**

FAMILIAL RELATIONSHIPS WITH ELECTED CITY OFFICIALS AND DEPARTMENT HEADS

This Appendix is to be completed only by (a) the Applicant, and (b) any legal entity which has a direct ownership interest in the Applicant exceeding 7.5 percent. It is not to be completed by any legal entity which has only an indirect ownership interest in the Applicant.

Under Municipal Code Section 2-154-015, the Disclosing Party must disclose whether such Disclosing Party or any "Applicable Party" or any Spouse or Domestic Partner thereof currently has a "familial relationship" with any elected city official or department head. A "familial relationship" exists if, as of the date this EDS is signed, the Disclosing Party or any "Applicable Party" or any Spouse or Domestic Partner thereof is related to the mayor, any alderman, the city clerk, the city treasurer or any city department head as spouse or domestic partner or as any of the following, whether by blood or adoption: parent, child, brother or sister, aunt or uncle, niece or nephew, grandparent, grandchild, father-in-law, mother-in-law, son-in-law, daughter-in-law, stepfather or stepmother, stepson or stepdaughter, stepbrother or stepsister or half-brother or half-sister.

"Applicable Party" means (1) all executive officers of the Disclosing Party listed in Section II.B.1.a., if the Disclosing Party is a corporation; all partners of the Disclosing Party, if the Disclosing Party is a general partnership; all general partners and limited partners of the Disclosing Party, if the Disclosing Party is a limited partnership; all managers, managing members and members of the Disclosing Party, if the Disclosing Party is a limited liability company; (2) all principal officers of the Disclosing Party; and (3) any person having more than a 7.5 percent ownership interest in the Disclosing Party. "Principal officers" means the president, chief operating officer, executive director, chief financial officer, treasurer or secretary of a legal entity or any person exercising similar authority.

Does the Disclosing Party or any "Applicable Party" or any Spouse or Domestic Partner thereof currently have a "familial relationship" with an elected city official or department head?

Yes

No

If yes, please identify below (1) the name and title of such person, (2) the name of the legal entity to which such person is connected; (3) the name and title of the elected city official or department head to whom such person has a familial relationship, and (4) the precise nature of such familial relationship.



City of Chicago



O2014-4237

Office of the City Clerk

Document Tracking Sheet

| | |
|---------------------------------|---|
| Meeting Date: | 5/28/2014 |
| Sponsor(s): | Moreno (1) |
| Type: | Ordinance |
| Title: | Honorary street designation as "Edwin 'Odge' Boska Way" |
| Committee(s) Assignment: | Committee on Transportation and Public Way |

BE IT ORDAINED BY THE CITY COUNCIL OF THE CITY OF CHICAGO:

Section 1. Pursuant to an ordinance heretofore passed by the City Council of the City of Chicago, which authorizes erection of honorary street-name signs, the Commissioner of Transportation shall take the necessary action for the standardization of 730 N Damen to be known as honorary 'Edwin "Odge" Boksa Way.'

Section 2. This ordinance shall take effect upon its passage and due publication.



Proco Joe Moreno
Alderman, 1st Ward



City of Chicago



O2014-4227

Office of the City Clerk

Document Tracking Sheet

| | |
|---------------------------------|---|
| Meeting Date: | 5/28/2014 |
| Sponsor(s): | Chandler (24) |
| Type: | Ordinance |
| Title: | Honorary street designation as "Officer Nikki Bostic-Jones Way" |
| Committee(s) Assignment: | Committee on Transportation and Public Way |

DESIGNATION OF HONORARY STREET NAMING

WHEREAS, the members of the City Council of the City of Chicago were deeply saddened to learn of the death of Correctional Officer Nikki Bostic-Jones on July 18, 2012, at the age of thirty-eight; and

WHEREAS, Officer Bostic-Jones was struck and killed by a hit-and-run driver as she was reporting for duty at Cook County Jail; and

WHEREAS, Officer Bostic-Jones had served with the Cook County Sheriff's Office Department of Corrections for 12 years; and

WHEREAS, Officer Bostic-Jones is remembered for her hard work, kindness, thoughtfulness, sense of humor, generosity, and love of her family; and

WHEREAS, Officer Bostic-Jones is survived by her husband and young daughter;
NOW THEREFORE

BE IT ORDAINED BY THE CITY COUNCIL OF THE CITY OF CHICAGO:

SECTION 1. Pursuant to an ordinance heretofore passed by the City Council, which allows erection of honorary street-name signs, the Commissioner of Transportation shall take all necessary action for the standardization of West 30th Place from South California Avenue to South California Boulevard as "Officer Nikki Bostic-Jones Way."

SECTION 2. This ordinance shall take effect upon its passage and publication.

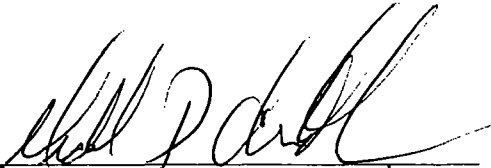
Alderman Michael Chandler, 24th Ward



City of Chicago



O2014-4214

Office of the City Clerk

Document Tracking Sheet

| | |
|---------------------------------|--|
| Meeting Date: | 5/28/2014 |
| Sponsor(s): | Colón (35) |
| Type: | Ordinance |
| Title: | Community street designation sign as "Welcome to Polish Village" |
| Committee(s) Assignment: | Committee on Transportation and Public Way |

CITY COUNCIL
May 28, 2014

Be It Ordained by the City Council of the City of Chicago:

SECTION 1. Pursuant to an ordinance heretofore passed by the City Council, which allows the erection of community name signs, the Commissioner of Transportation shall take the necessary action for sign installation at the corner of Milwaukee Avenue and Diversey Avenue and Milwaukee Avenue and Addison Street as "Welcome To Polish Village".

SECTION 2. This ordinance shall be in full force and effect from and after passage and publication.

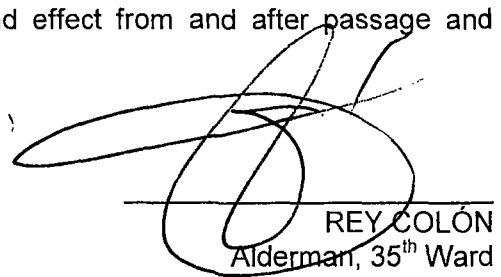

REY COLÓN
Alderman, 35th Ward



City of Chicago



O2014-4223

Office of the City Clerk

Document Tracking Sheet

| | |
|---------------------------------|---|
| Meeting Date: | 5/28/2014 |
| Sponsor(s): | Laurino (39) |
| Type: | Ordinance |
| Title: | Honorary designation as "Chopin Plaza" in area bounded by N Milwaukee Ave, N Elston Ave N Melvina Ave and W Holbrook St |
| Committee(s) Assignment: | Committee on Transportation and Public Way |

ORDINANCE

WHEREAS, Gladstone Park, located on Chicago's Northwest side, is home to a large population of Polish Americans; and

WHEREAS, Milwaukee Avenue is the backbone of the current and historical Polish population in Northwest Chicago; and

WHEREAS, an existing plaza (the "Plaza") located in the area bounded by Milwaukee Avenue, Elston Avenue, Holbrooke Street and Melvina Avenue sits at the heart of Gladstone Park; and

WHEREAS, the Gladstone Park Chamber of Commerce has maintained and used the existing plaza for various events and ceremonies throughout the year; and

WHEREAS, the headquarters of the Polish National Alliance, the Copernicus Foundation and a widely distributed Polish language newspaper are in the vicinity of the plaza; and

WHEREAS, Polish composer Frederic Chopin is one of the most cherished and beloved artists in Polish history, and his name carries a strong sense of cultural pride for Polish people; and

WHEREAS, popular arrangements of Chopin's compositions produced by Chicago area music publishers, including Sajewski Publishing, are still performed today; and

WHEREAS, Chopin's invocation of Polish folk music in his compositions represents an important and distinctly Polish contribution to the Romantic Movement; and

WHEREAS, The Chicago Chopin Society hosts the Tenth Annual Chicago Chopin Festival in 2014, continuing their mission of presenting Polish and American music to the Polish American community in Chicago; and

WHEREAS, the dedication of this plaza to reflect this rich cultural heritage will honor the many Polish Americans who have settled on the Northwest side of Chicago and contributed to the greatness of our City; therefore:

BE IT ORDAINED BY THE CITY COUNCIL OF THE CITY OF CHICAGO

Section 1. The statements contained in the preamble hereof are hereby made part of this ordinance as if fully restated.

Section 2. An honorary designation is hereby conferred upon the Plaza, which shall hereafter be referred to as "Chopin Plaza".

Section 3. The Commissioner of Transportation shall prepare and install appropriate signs to mark the honorary designation.

Section 4. This ordinance shall take full force and effect upon its passage and approval.

Alderman Margaret Laurino, 39th Ward



City of Chicago



O2014-4230

Office of the City Clerk

Document Tracking Sheet

| | |
|---------------------------------|--|
| Meeting Date: | 5/28/2014 |
| Sponsor(s): | Osterman (48) |
| Type: | Ordinance |
| Title: | Honorary street designation as "Honorary Women and Children First Way" |
| Committee(s) Assignment: | Committee on Transportation and Public Way |

City Council Meeting
May 28, 2014

Refer to Committee on Transportation & Public Way

BE IT ORDAINED BY THE CITY COUNCIL OF THE CITY OF CHICAGO:

SECTION 1. Pursuant to an ordinance heretofore passed by the City Council which allows erection of honorary street name signs, the Commissioner of Transportation shall take the necessary action for standardization of the 5200 block of North Clark Street as "**Honorary Women & Children First Way**".

SECTION 2. This ordinance shall take effect upon its passage and publication.

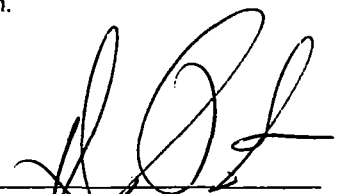
A handwritten signature in black ink, appearing to read 'H. Osterman', written over a horizontal line.

Harry Osterman
Alderman, 48th Ward



City of Chicago



Or2014-240

Office of the City Clerk

Document Tracking Sheet

| | |
|---------------------------------|--|
| Meeting Date: | 5/28/2014 |
| Sponsor(s): | Moore (49) |
| Type: | Order |
| Title: | Honorary street designation as "Honorary Ziaur Rahman Way" |
| Committee(s) Assignment: | Committee on Transportation and Public Way |

ORDERED, That the Commissioner of Transportation is hereby authorized and directed to give consideration to honorary designate the corner of North Clark on West Pratt Blvd at 6800 N. Clark and the corner of North Clark on West Albion at 6600 N. Clark as "Honorary Ziaur Rahman Way."

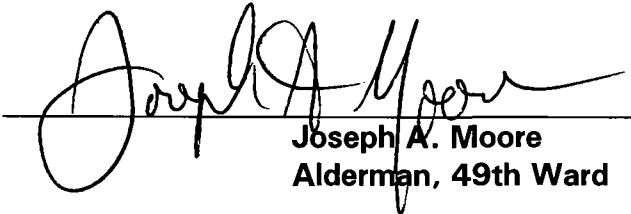

Joseph A. Moore
Alderman, 49th Ward



City of Chicago



O2014-4208

Office of the City Clerk

Document Tracking Sheet

| | |
|---------------------------------|--|
| Meeting Date: | 5/28/2014 |
| Sponsor(s): | Harris (8) |
| Type: | Ordinance |
| Title: | Correction of City Council Journal of Proceedings for April 30, 2014 |
| Committee(s) Assignment: | Committee on Committees, Rules and Ethics |

ORDINANCE

WHEREAS, At the meeting of the City Council of the City of Chicago (“City Council”) held on April 30, 2014, the City Council passed a Substitute Ordinance (“Substitute Ordinance”) that was reported out by the Committee on Zoning, Landmarks and Building Standards pertaining to:

Reclassification of Area Shown On Map No. 1-F.

(As Amended)

(Application No. 17898)

(Common Address: 200 – 240 W. Randolph St. And 151 – 169 N. Franklin Street); and

WHEREAS, Paragraph (8) of the *Plan of Development Statements* accompanying the Substitute Ordinance set the “Total FAR” for the site at “18.02”; and

WHEREAS, The *Bulk Regulations and Data Table* (“Table”) accompanying the Substitute Ordinance incorrectly set the “Total FAR” for the site at “18.07”, an error that resulted in an incorrect computation of the Maximum Floor Area Ratio (FAR) and Maximum Floor Area (sf) for applicable Sub-Area A, as set forth in such Table; and

WHEREAS, It is necessary and appropriate to correct this error; now, therefore,

BE IT ORDAINED BY THE CITY COUNCIL OF THE CITY OF CHICAGO:

SECTION 1. The Substitute Ordinance passed by the City Council on April 30, 2014, and published on pages 80464-80485 of the *Journal of the Proceedings of the City Council of the City of Chicago* (“*Journal of Proceedings*”) of that date is hereby corrected by deleting the language stricken through and by inserting the language underscored in the *Bulk Regulations and Data Table* found on page 80469 of the *Journal of Proceedings*, as follows:

“Business-Planned Development No. _____.

Plan of Development

Bulk Regulations and Data Table.

Gross Site Area, 92,635 square feet = Net Site Area, 58,413 square feet + Area Remaining in Public Way, 34,222 square feet

| | |
|--|---------------------------------------|
| Net Site Area (sf) | 58,413 |
| Sub-Area A | 34,062 |
| Sub-Area B | 24,351 |
| Maximum Floor Area Ratio (FAR) | 18.07 <u>18.02</u> |
| Sub-Area A | 25.81 <u>25.73</u> |
| Sub-Area B | 7.24 |
| Maximum Floor Area (sf) | 1,055,523 <u>1,052,602</u> |
| Sub-Area A | 879,116 <u>876,301</u> |
| Sub-Area B | 176,407 |
| Maximum Site Coverage | Per Site Plans |
| Maximum Number of Off-Street Parking Spaces | 539 |
| Sub-Area A | 34 |
| Sub-Area B | 510 |
| Minimum Number of Off-Street Loading Berths | 4 @ 10'x25' |
| Sub-Area A | 4 @ 10'x25' |
| Sub-Area B | 0 |
| Maximum Building Height (feet) | |
| Sub-Area A | 600 |
| Sub-Area B | 100 |

SECTION 2. This ordinance shall take full force and effect upon its passage and approval.

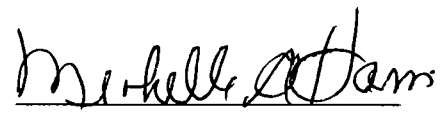
Michelle Harris
Alderman, 8th Ward



City of Chicago



O2014-4252

Office of the City Clerk

Document Tracking Sheet

Meeting Date: 5/28/2014

Sponsor(s): Thomas (17)
Austin (34)
Burnett (27)
Graham (29)
Ervin (28)
Mitts (37)
Brookins (21)
Cochran (20)
Holmes (7)
Harris (8)
Sawyer (6)
Chandler (24)
Lane (18)
Dowell (3)
Beale (9)
Foulkes (15)
Thompson (16)

Type: Ordinance

Title: Amendment of Municipal Code Chapter 2-154 by adding new Section 2-154-017 titled "Diversity in Non-Minority-Owned Firms Disclosure Ordinance"

Committee(s) Assignment: Committee on Finance

ORDINANCE

WHEREAS, the City of Chicago has long had a policy of requiring the participation of minority-owned and controlled firms in public works projects and in such major transactions as issuance of municipal bonds and notes; and

WHEREAS, the policy was adopted because traditionally minority-owned and controlled firms have been smaller and lacked access to capital that can spur economic growth; and

WHEREAS, because its discretionary transactions and purchases tend to be large, the City's policy also opens opportunities for minority-owned and controlled firms to acquire valuable business experience that can lead to greater acceptance in the capital market; and

WHEREAS, many non-minority firms that participate in city transactions employ members of minority groups; and

WHEREAS, the participation of such employees in city transactions can give them the type of professional and business experience that can lead to advancement, opening of management opportunities, and eventual ownership; and

WHEREAS, it is appropriate for the City Council of the City of Chicago to encourage the development of business skills that can enhance the city's business climate and growth; now, therefore,,

BE IT ORDAINED BY THE CITY COUNCIL OF THE CITY OF CHICAGO:

SECTION 1. Chapter 2-154 of the Municipal Code of the City of Chicago is hereby amended by inserting a new Section 2-154-017, as follows:

2-154-017 Diversity in non-minority firms.

(a) This section shall be known as the "Diversity in Non-Minority-Owned Firms Disclosure Ordinance." The purpose of this section is to promote full and accurate disclosure to the public of the degree to which professionals who are members of minority groups and employed by non-minority-owned and controlled firms have equal opportunities to develop professional expertise and experience and to participate or otherwise work on projects derived from, assisted by or supported by the city through tax revenues or otherwise.

(b) When used in this section:

- (i) "Reporting Firm" means any vendor providing professional services in connection with a city action. The term does not include a minority business enterprise as defined in section 2-92-420(t) of this code.
- (ii) "Professional Services" includes consulting, accounting, legal, banking, financial, trustee, underwriting, financial advisory, management, brokerage, and any other professional service. The term does not include construction,

demolition, rehabilitation or remodeling of buildings, or sale of personal property.

- (iii) “City Action” means any action requiring an ordinance or amendment to an ordinance; city council approval or other city agency approval with respect to the sale, purchase or lease of real property; real property tax classification; zoning; vacation of streets and alleys; equipment leases; contracts; award of loan funds, grant funds, or bond proceeds; creation of tax increment financing redevelopment areas; concession agreements; and all similar matters that are discretionary on the part of the city.
- (iv) “Project” means any collaborative enterprise requiring City Action.
- (v) “Transaction Participant” means any person employed by a Reporting Firm in management and working on a Project.
- (vi) “Prospective Firm” means a legal entity in existence at the time another entity makes application for a City Action, and is not the applicant or an owner at time of application, but which the applicant expects to assume such status within six months of the time the City Action occurs, and would become a Reporting Firm upon assuming such status.

(c) In addition to any other information required by law, when a Reporting Firm makes application to the city for any City Action, the Reporting Firm shall disclose the name, race/ethnicity, position and title, and compensation rate of each Transaction Participant employed by the reporting Firm.

(d) Within 30 days after closing or completion of a Project in which it was involved, a Reporting Firm shall file a supplemental report stating: the total time billed for the Project; the name, race/ethnicity of each Transaction Participant; the amount of billed time attributed to each Transaction Participant; and the hourly or compensation rate of each Transaction Participant.

(e) A Reporting Firm shall certify the accuracy of the disclosures and information required by this section, and shall attach the disclosures and information to its original application for City Action and every supplement thereto. The required disclosures and information shall be accompanied by an affidavit as to the accuracy of contents, subscribed under oath by a knowledgeable representative of the Reporting Firm, and shall be filed with the city’s chief procurement officer.

(f) The disclosure requirements of this section shall apply to Prospective Firms.

(g) The chief procurement officer shall make the information required by this section available to the public and provide reports of such information to the city council every six months.

(h) Failure of a Reporting Firm to comply with the requirements of this section shall render the subject City Action voidable as to the city, and may result in the Reporting Firm's being barred from participating in future City Action and eligibility for city contracts.

SECTION 2. This ordinance shall take effect 30 days after its passage and approval.

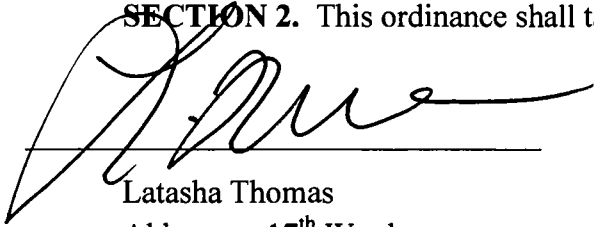

Latasha Thomas
Alderman, 17th Ward

Carrie M. Austin 34^a
Waters 5 2 27th 4

Debrah D. Jackson 9th

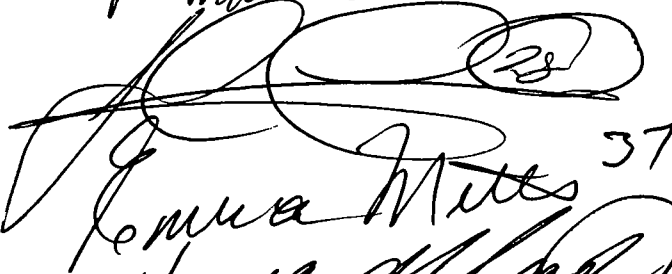

Emma M. White 37

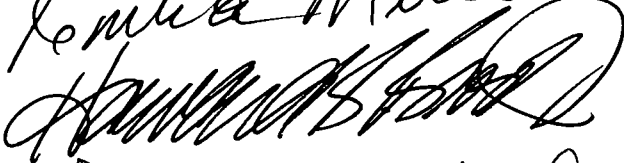

William B. Smith

Yatach O. Allen 7th

Donnell Q. Davis 8th

Robt A. J. (6th)

Michael D. Clarke 24

Yona Yone 18th

Pat Lowell, 3rd

Patricia Beal 9th

John S. Sturges 15th

John Thompson 16th



City of Chicago



O2014-4225

Office of the City Clerk

Document Tracking Sheet

| | |
|---------------------------------|--|
| Meeting Date: | 5/28/2014 |
| Sponsor(s): | Solis (25) |
| Type: | Ordinance |
| Title: | Amendment of Municipal Code Section 17-6-0403 concerning planned development of large venue entertainment and spectator sports |
| Committee(s) Assignment: | Committee on Zoning, Landmarks and Building Standards |

BE IT ORDAINED BY THE CITY COUNCIL OF THE CITY OF CHICAGO:

SECTION 1. Title 17, Section 17-6-0403 of the Municipal Code of Chicago is hereby amended by adding the language underscored and by deleting the language struck through, as follows:

(Omitted text is unaffected by this ordinance)

| USE GROUP | | PMD (Planned Manufacturing District) | | | | | | | | | | | | | | | Use Standard | | | | | |
|--|---|--------------------------------------|---|-------|---|-------|-------|---|-------|-------|-------|---|-------|-------|--------|-----------|--------------|--------|--------|--------|--------|-------------|
| Use Category | Specific Use Type | No. 1 | | No. 2 | | No. 3 | No. 4 | | No. 5 | No. 6 | No. 7 | | No. 8 | No. 9 | No. 10 | No. 11 | | No. 12 | No. 13 | No. 14 | No. 15 | |
| | | A | B | A | B | | A | B | | | A | B | | | | A | | | | | | B |
| P = permitted by right S = special use approval req'd PD = planned development approval req'd - = not allowed | | | | | | | | | | | | | | | | | | | | | | |
| COMMERCIAL | | | | | | | | | | | | | | | | | | | | | | |
| R. Entertainment and Spectator Sports | | | | | | | | | | | | | | | | | | | | | | |
| 1. | Small Venue | - | P | - | P | - | S | S | S | - | - | P | - | S | - | - | P | - | - | - | - | - |
| 2. | Medium Venue | - | - | - | - | - | - | - | S | - | - | P | - | - | - | - | P | - | - | - | - | - |
| 3. | Inter-Track Wagering Facility | S | S | S | S | S | S | S | S | - | S | S | S | S | - | S | S | - | - | - | - | § 17-9-0110 |
| 4. | Indoor Special Event Class A (See Sec. 4-156-550) including incidental liquor sales | P | - | P | - | P | P | - | P | P | P | P | P | P | P | P | P | P | P | P | P | P |
| 5. | Indoor Special Event Class B (See Sec. 4-156-550 (b)) including incidental liquor sales | P | P | P | P | P | P | P | P | P | P | P | P | P | P | P | P | P | P | P | P | P |
| 6. | Large Venue | | | | | | | | | | | | | | | <u>PD</u> | | | | | | |

SECTION 2. This Ordinance shall be in force and effect from and after its passage and due publication.

 Daniel S. Solis
 Alderman, 25th Ward



City of Chicago



O2014-4212

Office of the City Clerk

Document Tracking Sheet

| | |
|---------------------------------|--|
| Meeting Date: | 5/28/2014 |
| Sponsor(s): | Maldonado (26) |
| Type: | Ordinance |
| Title: | Amendment of Municipal Code Titles 4, 7 and 10 concerning mobile prepared food vendors |
| Committee(s) Assignment: | Committee on License and Consumer Protection |

ORDINANCE

BE IT ORDAINED BY THE CITY COUNCIL OF THE CITY OF CHICAGO

SECTION I. Chapter 4-5 of the Municipal Code of Chicago is hereby amended by deleting the language struck through and by inserting the language underscored, as follows:

4-5-010 Establishment of License Fees.

(Omitted text is not affected by this ordinance)

(15)

(Omitted text is not affected by this ordinance)

Mobile Food Vendor—Produce Merchant (4-8) ~~\$275~~100.00
Mobile Food Vendor—~~Mobile Desserts~~Prepared Food Vendor
~~\$275~~100.00
Mobile Food Vendor—Mobile Food Dispenser \$700.00
Mobile Food Vendor—Mobile Food Preparer \$1,000.00

(Omitted text is not affected by this ordinance)

SECTION II. Chapter 4-8 of the Municipal Code of Chicago is hereby amended by deleting the language struck through and by inserting the language underscored, as follows:

4-8-010 Definitions.

The following definitions shall apply in the interpretation and the enforcement of this chapter and chapters 7-38, 7-40 and 7-42 unless the context clearly indicates that another meaning is intended. The listing of items as examples in any definition is intended to be illustrative and not exhaustive.

(Omitted text is not affected by this ordinance)

“Mobile ~~frozen desserts prepared food vendor~~” means any person who, by traveling from place to place upon the public ways, serves from a two-wheeled or three-wheeled motorized vehicle or a non-motorized vehicle (including but not limited to a two-wheeled or three wheeled vehicle, pushcart, or handcart) individual portions of ~~ice cream, ice milk, frozen dessert mix, sundaes or other frozen desserts~~food that are totally

enclosed in a wrapper or container and which have been manufactured, prepared or wrapped in a licensed food establishment, or coffee or other beverages.

“Mobile food vendor” means a mobile food dispenser, mobile food preparer, produce merchant or mobile ~~desserts~~ prepared food vendor.

(Omitted text is not affected by this ordinance)

“Mobile food vehicle” means a motorized vehicle used to conduct a mobile food dispenser or, mobile food preparer ~~or mobile desserts vendor~~ business.

(Omitted text is not affected by this ordinance)

“Prepackaged and non-perishable food” means any food or beverage which is not capable of supporting rapid and progressive growth of microorganisms which may cause food infections; and which is packaged in a hermetically sealed container designed to keep the contents free of contamination by microorganisms and maintain the commercial sterility of its contents after thermal processing. The term shall include packaged granola bars, nuts, dried fruit ~~and~~ and, gum ~~and confections~~ and bottled or canned water or soft drinks, if the package, bottle or can includes a manufacturer's quality assurance date. In no case shall the term include fresh or processed meats, poultry, seafood, dairy products, eggs, or fresh fruit and vegetables.

“Produce” means ~~whole and uncooked~~ agricultural, plant-based items, including, but not limited to, fruits, vegetables, legumes, edible grains, nuts, spices, herbs and cut flowers, and dried, roasted, or baked agricultural, plant-based items that are prepackaged and non-perishable food, including, but not limited to, roasted nuts, apple chips, or granola.

“Produce merchant” means any person who sells produce outdoors from a produce stand, and who conducts at least 50 percent of his operations in areas underserved by grocery stores, as defined herein, and whose stand is (1) located on a private or public property with the written permission of the property owner, located on the public way in an area underserved by grocery stores, or located on the public way in connection with a valid public way use permit issued pursuant to section 10-28-060 of this Code; (2) removed in its entirety from such private property or public way at the end of each business day; and (3) in compliance with all applicable requirements of the Chicago Zoning Ordinance, including, but not limited to, any requirement prohibiting commercial sales within residential districts.

(Omitted text is unaffected by this ordinance.)

4-8-020 Licensing requirements- Exceptions.

(Omitted text is not affected by this ordinance)

(c) (4) No person shall engage in the business of a mobile ~~desserts-prepared~~ food vendor without first having obtained a mobile food vendor license to engage in a mobile ~~desserts-prepared food~~ vendor business.

(Omitted text is not affected by this ordinance)

4-8-036 License – Application and category– Mobile food vendors.

(a) In addition to the general application requirements,

(1) an applicant for a mobile food vendor license to engage in a mobile food dispenser, mobile food preparer or mobile ~~desserts-prepared food~~ vendor business shall supply the name and address of the commissary where the vehicle or cart will be cleaned and serviced, and if the vehicle or cart is not stored at the commissary, the name and address of the place where such vehicle or cart will be stored when not in use. The department of health shall approve such locations;

(2) an applicant for a mobile food vendor license to engage in a mobile food dispenser, ~~or~~ mobile food preparer, or mobile prepared food vendor business shall complete a consultation with the department of health to review the proposed business practices, the vehicle and equipment to be used, and food safety operations prior to obtaining a mobile food vendor license. As part of this consultation, the applicant shall provide a proposed menu including a list of all food items the applicant intends to serve. At the time of consultation, an applicant for a mobile food vendor license to engage in a mobile food preparer business shall provide a City of Chicago Food Sanitation Manager Certificate issued to the applicant or the applicant's employee who will operate the mobile food truck;

(3) an applicant for a mobile food vendor license to engage in a mobile food dispenser, ~~or~~ mobile food preparer, or mobile prepared food vendor business shall make the applicant's ~~mobile food~~ vehicle available for inspection by the department of health at a location determined by the department of health:

(Omitted text is not affected by this ordinance)

(c) The commissioner of business affairs and consumer protection is authorized to issue color-coded emblems for the following mobile food vendor business categories:

(Omitted text is not affected by this ordinance)

3. A mobile food vendor license to engage in a mobile ~~desserts-prepared food~~ vendor business.

(Omitted text is not affected by this ordinance)

SECTION III. Chapter 7-38 of the Municipal Code of Chicago is hereby amended by deleting the language struck through and by inserting the language underscored, as follows:

7-38-075 Mobile vendor~~food~~ vehicles.

(a) In addition to the requirements contained in subsection (a) of section 7-38-040, every vehicle used by a mobile food ~~dispenser or mobile food preparer~~vendor in the conduct of such business shall comply with the following requirements:

(1) the vehicle shall be enclosed with top and sides;

(2) the interior floor, walls and ceiling of each vehicle shall be of smooth, not readily corrodible, impervious material capable of withstanding repeated washing and scrubbing and shall be finished in a light color;

(3) the vehicle shall not be used for any purpose other than a mobile food ~~dispenser or as a mobile food preparer~~vendor business;

(4) all food service equipment utilized by the mobile food ~~dispenser or mobile food preparer~~vendor shall be of easily cleanable construction and shall be maintained in good repair and a clean condition

~~(c5)~~ the each mobile food vehicle shall be registered as a commercial vehicle and any person who operates such vehicle must have a valid driver's license issued by the state of Illinois or another state, district or territory of the United States;

~~(d6)~~ the each mobile food vehicle shall be inspected and maintained by a licensed professional, including mechanics and, if applicable, by professionals who install and maintain fire prevention equipment, and propane tanks on mobile food vehicles, as often as necessary but not less than every 90 days, and copies of the last four maintenance reports must be kept in the vehicle at all times while the vehicle is in use; and

~~(17)~~ there shall be no more than 40 pounds of propane in the vehicle.

~~(e6)~~ Prior to the construction, remodeling, purchase or use of any mobile food truck or the addition of any new equipment for the storage or preparation of food, plans for such vehicle must be submitted to the department of health, and, if the mobile food vehicle uses propane, natural gas, or has a fire suppression hood, the fire department for approval.

(Omitted text is not affected by this ordinance)

7-38-090 Refrigeration and heating equipment.

All mobile ~~vendor~~food vehicles shall have adequate ~~mechanical~~ refrigeration equipment as approved by the department of health, and such equipment shall be capable of maintaining food or drink at a temperature of 40 degrees Fahrenheit or less, if any food or drink is required to be kept cold.

All mobile ~~vendor~~food vehicles shall have adequate ~~mechanical~~ heating equipment as approved by the department of health, and such equipment shall be capable of maintaining food or drink at a temperature of 140 degrees Fahrenheit or more, if any food or drink is required to be kept hot, or capable of heating food or drink to a temperature of 165 degrees Fahrenheit or more, if any food or drink is required to be heated.

All ~~mechanical~~ refrigeration and heating equipment shall be equipped with a thermometer.

(Omitted text is not affected by this ordinance)

7-38-115 Operational requirements.

(Omitted text is not affected by this ordinance)

(b) Mobile food vehicle stops shall be made only to service customers and shall not exceed (i) a total of two hours or (ii) the maximum permitted period for parking, whichever is lesser, in any one block.

(Omitted text is not affected by this ordinance)

(d) Unless specifically allowed in a mobile food vehicle stand, no sales from ~~such a mobile food~~ vehicle shall be made between the hours of 2:00 a.m. and 5:00 a.m.

(Omitted text is not affected by this ordinance)

7-38-124 Refuse receptacles.

The operator of a mobile food vehicle shall maintain a suitable, tight, non-absorbent washable receptacle for refuse. ~~The operator~~ A mobile food vendor shall be responsible for sanitation of the environs of the place of operation, including the mobile food vehicle stand area used by the operator. Said refuse receptacle shall be adjacent to, but not an integral part of, the mobile food vehicle. The operator of a mobile food vehicle shall dispose refuse collected from the mobile food vehicle and the environs of the place of operation at a commissary approved by the department of health.

(Omitted text is not affected by this ordinance)

7-38-130 Preparation and service of food and drink.

(a) No food shall be sold or served by a mobile food dispenser or mobile prepared food vendor, except the following:

(1) Individual portions of food that are totally enclosed in a wrapper or container and which have been manufactured, prepared or wrapped in a food establishment licensed by the city or a food establishment which is operating under the state or local health authority if the statute or ordinance regulating such food establishment is substantially equivalent to this chapter. Such food may undergo a final preparation step immediately prior to service to a consumer, provided such final preparation steps conform with the rules and regulations of the board of health.

(2) Coffee which is prepared in a duly licensed food establishment, refrigerated cream which is kept in a covered single-service container or an approved cream dispenser, and sugar which is served only in wrapped individual packages or in a covered closed pouring-spout type container, or in any other manner approved by the department of health, which is effective in preventing contamination;

(3) Other bulk soft drinks or beverages which are dispensed from an approved dispenser only. These approved bulk soft drink dispensers shall be serviced and filled only at a duly licensed food establishment which serves as a commissary for the mobile food ~~vendor~~ dispenser. The drink outlet on all bulk liquid dispensers shall be protected from flies, dust and contamination;

(4) Individual portions of ice cream, ice milk, frozen dessert mix, sundaes or other frozen desserts that are totally enclosed in a wrapper or container and which have been manufactured, prepared or wrapped in a licensed food establishment and

(5) Whole and uncooked fruits or vegetables.

(Omitted text is not affected by this ordinance)

PART D. Mobile ~~Desserts~~ Prepared Food Vendors.

7-38-140: Mobile ~~desserts~~ prepared food vendor.

Except as otherwise provided in this section, a mobile ~~desserts-prepared food~~ vendor shall comply with all applicable requirements of this Code, including the applicable requirements set forth in Article II, Parts A and B of this Chapter, and the rules and regulations of the department of health pertaining to mobile units handling ~~frozen desserts~~ food. A mobile ~~desserts-prepared food~~ vendor is not required to comply with the following requirements:

~~(1) the hot food storage and heating appliance requirements set forth in Section 7-38-090;~~

~~(2) the sinks, water storage tanks and plumbing requirements set forth in Section 7-38-132;~~

~~(3) the refuse receptacle requirements set forth in Section 7-38-124;~~

~~(4) the mobile ~~food~~ vendor vehicle requirement set forth in Section 7-38-075(a)(1); and~~

~~(5) the additional vehicle requirements set forth in Section 4-8-293.~~

(Omitted text is not affected by this ordinance)

Part E Produce Merchants

7-38-142 Produce merchants – Operational requirements – Unlawful acts.

It shall be unlawful for any produce merchant to engage in any of the following activities at any produce stand operated by such produce merchant:

(Omitted text is unaffected by this ordinance)

(18) To sell cut produce that is not prepackaged and non-perishable food, unless the produce has been cut and packaged in a licensed food establishment.

SECTION IV. Chapter 10-28 of the Municipal Code of Chicago is hereby amended by deleting the language struck through and by inserting the language underscored, as follows:

10-28-050 Maintenance of stands.

It shall be unlawful for any person to erect, place or maintain in, upon or over any public way or other public place in the city, any fruitstand, shoeshining stand, flower stand, vegetable stand, lunch wagon, table, box, bin or any other arrangement or structure for the display or sale of goods, wares or merchandise, or for the pursuit of any occupation whatsoever unless a permit for the same shall be obtained from the commissioner of business affairs and consumer protection; provided that such permit shall not be required for produce merchants in areas underserved by grocery stores as defined in Section 4-8-010; ~~that the commissioner of business affairs and consumer protection shall issue no such permits except for the purpose of operating a produce stand by a produce merchant, as provided in Section 10-28-060 of this chapter~~, and provided that the commissioner of transportation shall issue no such permits except for the purpose of exhibiting for sale daily newspapers, within such districts as are or have been designated by the city council.*

10-28-060 A produce stand on the public way ~~pilot~~ program.

(a) A produce stand on the public way ~~pilot~~ program (“~~pilot~~ program”) is hereby created as provided in this section.

(b) The following definitions shall apply for purposes of this section:

(1) “Area underserved by grocery stores” has the meaning ascribed to that term in Section 4-8-010 of this Code.

(2) “Commissioner” means the commissioner of business affairs and consumer protection.

(3) “Department” means the department of business affairs and consumer protection.

(4) “Produce” has the meaning ascribed to that term in Section 4-8-010 of this Code.

(5) “Produce stand” has the meaning ascribed to that term in Section 4-8-010 of this Code.

(c) It shall be unlawful for any person to erect or operate any produce stand on the public way without first obtaining a public way use permit from the department as

provided herein, unless the produce stand is located on the public way in an area underserved by grocery stores as defined in Section 4-8-010 of this Code.

(d) (1) The commissioner is authorized to issue a public way use permit for operating a produce stand, ~~at locations designated pursuant to subsection (d)(2) of this section.~~

~~(2) The commissioner of housing and economic development, in consultation with the commissioner of business affairs and consumer protection and the commissioner of transportation, is authorized to designate by rule up to 30 locations in the city where public way use permits may be issued for operating produce stands. In designating such locations the commissioner of housing and economic development shall consider such factors, as determined by rule, that would help to determine appropriate locations for operating produce stands on the public way, including, but not limited to, any one or more of the following:~~

~~— (i) the proximity of the location to public transit stations;~~

~~— (ii) the amount of pedestrian traffic in the location; or~~

~~— (iii) the proximity of the location to an area underserved by grocery stores, or the existence of the location in an area underserved by grocery stores.~~

~~(3) If the commissioner determines that there are more qualified applicants for a public way use permit to operate a produce stand on the public way than the maximum number of available public way locations specified in this subsection, the commissioner shall conduct a lottery or other neutral process for allocating permits among qualified applicants as set forth by rules promulgated by the commissioner.~~

(e) An application for a public way use permit for a produce stand shall be made to the department and shall include the following:

(i) the name and address of the applicant;

(ii) verification that the applicant is licensed as a mobile food vendor to engage in a produce merchant business or has applied for such license;

(iii) the location or proposed location of such produce stand;

(iv) the types of produce that will be sold from the stand;

(v) the days and times the stand will be operating;

(vi) a statement verifying that the applicant will conduct at least 50 percent of his produce merchant business within areas underserved by grocery stores, as defined in Section 4-8-010 of this Code;

(vii) a statement that such permit will be accepted subject to the conditions and provisions thereof and subject to the conditions and provisions of all laws and ordinances affecting the maintenance of such produce stand now or hereafter in effect; and

(viii) any other information or supporting material required by the commissioner that is reasonably necessary to determine compliance with this Code and all applicable rules and regulations, including plans, drawings and photographs of the applicant's proposed produce stand.

(f) ~~The commissioner shall forward a copy of an application for a public way use permit for a produce stand to the commissioner of transportation and the commissioner of housing and economic development within three business days after receipt of the application. The commissioner shall not issue a public way use permit for a produce stand unless the commissioner of transportation and the commissioner of housing and economic development approve the application. In addition, the issuance of a public way~~

use permit for the operation of a produce stand shall be dependent on the issuance of a valid mobile food vendor license to engage in a produce merchant business.

(g) The commissioner shall deny or revoke a public way use permit for operating a produce stand if: (i) the granting of the public way use is not in the best interest of the public, would have a deleterious impact on the neighborhood, or would create a nuisance either on the public way or in the surrounding area; (ii) the design of, or materials used in, the public way use does not comport with the quality or character of the existing streetscape; (iii) the use interferes with or impedes the flow of pedestrian or vehicular traffic, or ingress or egress from any surrounding building, the use of any pole, traffic signs or signals, hydrants, mailboxes or other objects located near the location of the proposed use; or (v) the applicant makes any false statements, submits any false information or misrepresents any information required under this section.

(h) A public way use permit for operating a produce stand shall be issued for a one year period from the time of its issuance. The fee for each public way use permit to operate a produce stand shall be \$75.00 per year, and the fee shall not be prorated.

(i) A public way use permit for operating a produce stand shall be subject to all of the following requirements:

(1) The permit shall be valid only to the person to whom it was issued.

(2) As a condition of the permit, the permittee shall keep all information current. Any change in required information shall be reported to the department within 30 days after the change.

(3) As a condition of the permit, the commissioner may enter into a written agreement with the permittee pertaining to the use of the public way for operating a produce stand.

(4) The issuance of the permit shall be subject to the requirements of Section 10-28-015(e) of this Code.

(j) In addition to all the requirements applicable to a produce merchant, the following requirements shall apply to operating a produce stand on the public way:

(1) All produce stands located on the public way must leave six feet of public way unobstructed for pedestrian passage.

(2) Any produce stand operating on the public way shall not be greater than 6.5 feet long, 3.5 feet wide, and 8 feet high.

(k) The commissioner shall have power to adopt rules as may be necessary or useful for the proper administration and enforcement of this pilot program, including rules pertaining to the maintenance and appearance of produce stands on the public way.

(l) Advertisements may be displayed on produce stands operating on the public way as provided by rules and regulations adopted by the commissioner.

~~(m) This pilot program shall expire on December 31, 2014. Sixty (60) days before the expiration of the pilot program, the commissioner, the commissioner of transportation, the commissioner of housing and economic development, and the commissioner of health shall evaluate the effectiveness of the pilot program and may recommend the continuation of the program with or without changes as may be adopted by ordinance.~~

26



City of Chicago



O2014-4161

Office of the City Clerk

Document Tracking Sheet

| | |
|---------------------------------|--|
| Meeting Date: | 5/28/2014 |
| Sponsor(s): | Reboyras (30) |
| Type: | Ordinance |
| Title: | Amendment of Municipal Code Chapter 17-11 extending date of compliance with landscape requirements for vehicular use areas |
| Committee(s) Assignment: | Committee on Zoning, Landmarks and Building Standards |

ORDINANCE

WHEREAS, the City of Chicago ("City") is a home rule unit of government pursuant to Article VII, Section 6 of the Constitution of the State of Illinois; and,

WHEREAS, pursuant to its home rule power, the City may exercise any power and perform any function relating to its government an affairs, including promoting the quality of life and the welfare of its citizens; and,

WHEREAS, the City has had a landscape ordinance in effect since 1991; and,

WHEREAS, the City takes pride in its programs for assisting small businesses; and,

WHEREAS, due to the national economic turndown affecting small businesses, at the April 14, 2010 City Council meeting, the City Council approved an amendment to Title 17 of the Municipal Code of Chicago, the Chicago Zoning Ordinance by adding a new section 17-11-0201-F and extended the date of compliance with the landscape requirements until June 15, 2014; and now, therefore,

BE IT ORDAINED BY THE CITY COUNCIL OF THE CITY OF CHICAGO:

SECTION 1: Title 17 of the Municipal Code of Chicago, the Chicago Zoning Ordinance is hereby amended by deleting the language struck through and by inserting the language underscored, as follows:

17-11-0200 Vehicular use areas.

(omitted text is unaffected by this ordinance)

17-11-0201-F The provisions of sections 17-11-0201-B, 17-11-0201-C, 17-11-0201-D, and 17-11-201-E shall not apply to any existing accessory vehicle use area, as of the effective date of this amendatory ordinance of 2014 until ~~June 15, 2014~~ June 15, 2016.

(omitted text is unaffected by the ordinance)

17-11-020-C Fencing. Ornamental fencing is required to be installed along the perimeter of vehicular use areas along those lot lines adjacent to public street right-of-ways or abutting any existing front yard of property located within an R district.

(omitted text is unaffected by this ordinance)

3. Any pre-existing vehicular use areas must have ornamental fencing installed behind any existing hedges or, when no hedges exist, at the property line based on the following schedule:

RECEIVED #3
2014 MAY 20 AM 11:22
OFFICE OF THE CITY CLERK

11

100
RELEASE UNDER
E.O. 13526

| Area | Size of Vehicular Use Area | Required Date of Compliance |
|-------------------------|-----------------------------|-----------------------------|
| Central Area | Any | January 1, 2002 |
| Outside of Central Area | 30,000 square feet or more | January 1, 2004 |
| Outside of Central Area | 8,000 to 29,999 square feet | January 1, 2007 |
| Outside of Central Area | 2,000 to 7,999 square feet | January 1, 2008 |

Notwithstanding the above schedule, the required date of compliance outside the Central Area for accessory vehicular use areas less than 30,000 square feet in size shall be ~~June 15, 2014~~ June 15, 2016.

SECTION 2. This ordinance shall take full force and effect upon its passage.

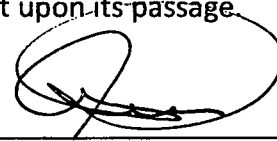

Ariel E. Reboyras
Alderman, 30th Ward



City of Chicago



O2014-4232

Office of the City Clerk

Document Tracking Sheet

| | |
|---------------------------------|--|
| Meeting Date: | 5/28/2014 |
| Sponsor(s): | Suarez (31) Burke (14) |
| Type: | Ordinance |
| Title: | Amendment of previous ordinance concerning funding for city colleges |
| Committee(s) Assignment: | Committee on Finance |

FIN

ORDINANCE (Requested amendment June 2014)

WHEREAS, the City of Chicago (the "City"), a home rule unit of government under Section 6(a), Article VII of the 1970 Constitution of the State of Illinois, has heretofore found and does hereby find that there exists within the City a serious shortage of affordable, safe and quality higher education available to persons of low and moderate income; and

WHEREAS, on March 18, 1956, the City Council (the "City Council") of the City of Chicago (the "City") created the Public Building Commission of Chicago (PBC) (the "Commission") pursuant to the Public Building Commission Act of the State of Illinois (the "Act") for the purpose of facilitating the funding, acquisition and construction of public buildings, improvements and facilities for use by various public agencies such as the Board of Trustees of Community College District No. 508 (the "City Colleges"), County of Cook and State of Illinois (collectively, the "Sister Agencies"); and in the furnishing of essential governmental services; and

WHEREAS, on January 1, 1982, the Illinois legislative body (the "State legislature") of the State of Illinois (the "state") created the Capital Development Board of Illinois (CDB) (the "Board") pursuant to implementing and as authorized by the Capital Development Board Act [20 ILCS 3105] for the purpose of facilitating the funding, acquisition and construction of public buildings, improvements and facilities for use by various public agencies such as ~~the Board of Trustees of Community College District No. 508~~ (the "City Colleges"), County of Cook and State of Illinois (collectively, the "Sister Agencies"); and in the furnishing of essential governmental services; and

WHEREAS, the ~~Community College District No. 508, City of Chicago~~ City Colleges ("City Colleges"), has an internal department (Administrative Services) for the purpose of facilitating the funding, acquisition, improvements and construction of over four million (4,000,000) square feet of educational internal physical spaces in use by one of the seven colleges and other teaching institutes, in the furnishing of essential governmental services; and

WHEREAS, the City has determined that the continuance of a shortage of quality affordable higher education is harmful to the prosperity, economic stability and general future welfare of the City; and

WHEREAS, the mission of the City Colleges~~Community College District No. 508~~ is: "...to provide opportunities for all students to enhance their knowledge and skills by offering superior, affordable, and comprehensive educational programs and services."; and

WHEREAS, the ~~City Colleges of Chicago~~ is a system of seven community colleges and other teaching institutes, providing learning opportunities for Chicago residents at the schools or online, as well as members of the U.S. military through the Navy Campus. Student enrollments continues to be more than over 120,000 and growing. The ~~City Colleges of Chicago~~ was established on September 11, 1911.

The seven colleges and other teaching institutes are:

- Richard J. Daley College
- Kennedy-King College
- Malcolm X College
- Olive-Harvey College
- Harry S. Truman College
- Harold Washington College
- Wilbur Wright College
- District Office
- Washburne Culinary Institute
- WYCC Channel 20-21DT
- Harold Washington Cultural Center

Satellite Campuses (South Chicago Learning Center), (Dawson Technical Institute), (Arturo Velazquez Technical Institute), (West Side Learning Center) (Lakeview Learning Center) and (Humboldt Park Vocational Educational Center); and

WHEREAS, the ~~City of Chicago~~ and the ~~City Colleges of Chicago~~ have developed several new partnerships in the past and plan to expand neighborhood services available to small businesses, aimed at better educating small business operators about how to start or grow their business; and

WHEREAS, the ~~City Colleges of Chicago~~ have developed in the past and present many ~~Capital~~ projects with the Chicago Public Building Commission, Illinois ~~Capital~~ Development Board and within its own College District Administrative Services, and

WHEREAS, City Colleges of Chicago receives tax levies -and tuition to offset the high cost of higher education and at various locations is eligible to receive Tax Increment Financing (TIF) funds for ~~Capital~~ improvements; and .

WHEREAS, the ~~City Colleges of Chicago~~ student enrollment is growing with new needs in a demanding changing job market with new requirements of physical facilities and technology; and

WHEREAS, the ~~City Colleges~~ ~~Community College District No. 508~~ has ~~endeavored~~ ~~been~~ requested by the various ~~City Colleges of Chicago~~ to undertake the construction of buildings and facilities for use by such educational institutions in the furnishing of public educational services; and

WHEREAS, the City maintains a comprehensive municipal building code (the "Code") governing the construction, repair, maintenance and inspection of buildings in order to protect the public health and safety; and

WHEREAS, in order to determine compliance with the requirements of the Code, the City issues construction permits, various licenses and capacity cards and conducts periodic inspections which are financed in part by various fees imposed by the City for the examination of plans, issuance of permits, licenses and inspections; and

WHEREAS, contractors engaged to construct buildings and facilities for ~~t~~The City Colleges of Chicago are required to file numerous license and permit applications for original ands renewed permits and to pay the fees and charges imposed for such permits and licenses; and

WHEREAS, the financial and administrative costs of complying with the Code includei—ng work hours spent in preparing applications, waiting for consideration and approval of applications and resulting delays is costly and impedes the efficient operation of ~~t~~The City Colleges of Chicago iñ the construction of buildings and facilities for the various College buildings throughout the city; and

WHEREAS, the financial and administrative obligations imposed by the Code ares deleterious to the City and the City Colleges who share the same tax base; now therefore,

BE IT ORDAINED BY THE CITY COUNCIL

SECTION 1. Notwithstanding any provision of the Code of the City to the contrary, all permits for demolition, new construction, construction alteration, repair, renovation, rehabilitation and inspection of buildings and facilities by the City Colleges of Chicago and its contractors for public or governmental use by the Board of Trustees of Community College District No. 508 (the "City Colleges") shall be issued without charge, commencing April 01, 2009, for a duration not to exceed twenty years from the noted commencement date (April 01, 2029) or upon the completion of projects in process within the City of Chicago's Department Agencies, ie. Buildings, Transportation exc.

SECTION 2. This Ordinance shall not absolve or release ~~the Board of Trustees of Community College District No. 508~~ (the "City Colleges") or its contractors from compliance with the building and fire provisions of the Code including requirements for the filing of plans, the obtaining of permits and necessities for inspections.

SECTION 3. The Commissioners of Buildings, Transportation and Business License Affairs and Consumer Protection of the City ares authorized to establish, in cooperation with the Chancellor, a system which enables ~~the Board of Trustees of Community College District No. 508~~ (the "City Colleges") and its contractors to file and process applications in a manner which reduces the administrative burden of ~~the Board of Trustees of Community College District No. 508~~ (the "City Colleges").

10/10/10

SECTION 4. This ordinance shall be amended by deleting the language stricken through and by inserting the language underscored.

SECTION 5. This ordinance shall be in full force and effect immediately upon its passage and approval.

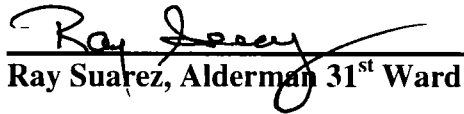
Ray Suarez, Alderman 31st Ward



Edward M. Burke, Alderman 14th Ward

EXHIBIT A

Fee and Other Waivers

Department of Buildings

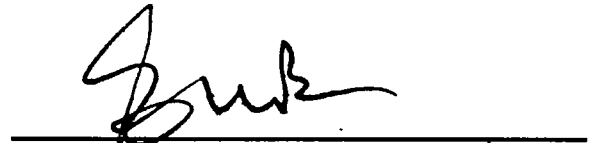
Waiver of Plan Review, Permit and Inspection Fees:

A. Building Permit:

Zoning

Construction/Architectural/Structural

Internal Plumbing and Sewers

HVAC

Water for Construction

Smoke Abatement

B. Electrical Permit: Service and Wiring

C. Elevator Permit (if applicable)

D. Wrecking Permit and all fees related. (if applicable)

E. Fencing Permit (if applicable)

F. Fees for the review of building plans for compliance with accessibility codes by the Mayor's Office for People with Disabilities imposed by Section 13-32-310(2) of the Municipal Code of Chicago

G. Capacity Card fees

Department of Water Management

Tap Fees

Cut and Seal Fees for water and sewers

(Fees to purchase B-boxes and remote read-outs are not waived-)

Permit (connection) and Inspection Fees

Sealing Permit Fees

Storm water ordinance review fee

Zoning and Land use Planning

Zoning Fees

Trash Enclosure fees:

Planning Part II Review Fees:

Letter of Credit security requirement for landscaping:

Department of Transportation

Board of Underground Fees

Street Opening Fees

Driveway Permit Fees

Use of Public Way Fees

Other

City Annual Fees:

Inspection Fees:

City of Chicago Fines:

Fees relating to City installations (including, but not limited to, curbs, walks, parkway landscaping and street and alley lighting)

All License renewal fees for Restaurant and Catering:



City of Chicago



O2014-4203

Office of the City Clerk

Document Tracking Sheet

| | |
|---------------------------------|--|
| Meeting Date: | 5/28/2014 |
| Sponsor(s): | Austin (34) |
| Type: | Ordinance |
| Title: | Amendment of Municipal Code Chapter 2-159 regarding Adjacent Neighbor and City-Owned Parcel |
| Committee(s) Assignment: | Committee on Housing and Real Estate |

ORDINANCE

BE IT ORDAINED BY THE CITY COUNCIL OF THE CITY OF CHICAGO:

SECTION 1. Chapter 2-159 of the Municipal Code of Chicago is hereby amended by adding the language underscored and by deleting the language struck through, as follows:

2-159-030 Definitions.

For purposes of this chapter:

“Adjacent neighbor” means a person who ~~owns and occupies as such person's primary residence an improved parcel of real property immediately adjacent to a city-owned parcel of vacant property, and who is not delinquent in the payment of any property taxes or any debt owed to the City of Chicago, County of Cook or State of Illinois.~~

(i) owns one parcel, or two or more contiguous parcels, of real property that is immediately adjacent to a city owned-parcel and at least one of the parcels is an improved parcel which the person occupies as his primary residence; and

(iii) is not delinquent in the payment of any property taxes or any debt owed to the City, County of Cook or State of Illinois.

“A.N.L.A.P.” means the Adjacent Neighbors Land Acquisition Program.

~~“City” means the City of Chicago.~~

“Department” means the department of planning and development.

“City-owned Parcel” means a one parcel of vacant real property, consisting of a single permanent tax identification number, which (a) is immediately adjacent to and is bounded on at least one side by a parcel owned by an adjacent neighbor ~~an owner-occupied improved parcel of residential real property~~, and (b) which has a fair market value of not more than \$50,000.00 as determined by the department.

2-159-040 List of city-owned real estate – Required.

The department shall prepare and maintain a list of city-owned real estate which shall include those city-owned parcels available for sale under A.N.L.A.P. This list shall be made available to the public during normal business hours.

2-159-050 Minimum purchase price required – Sale procedures.

The minimum purchase price of any city-owned parcel sold pursuant to the provisions of this chapter shall be \$1,000.00 for a parcel appraised at \$10,000.00 or less, 2,000.00 for a parcel appraised at more than \$10,000 and less than or equal to \$20,000.00, and for parcels having an appraised value of more than \$20,000.00, an amount equal to the sum (a) \$2,000, plus (b) fifty percent (50%) of the amount by which the parcel's appraised fair market value exceeds \$20,000, up to the \$50,000 maximum fair market value limitation. For illustrative purposes, if a city-owned parcel has an appraised fair market value of \$40,000, then the minimum purchase price for such parcel would be \$12,000. An adjacent neighbor shall not be permitted to purchase more than one city-owned parcel ~~(consisting of a single permanent tax identification number)~~ through A.N.L.A.P. Upon receipt of an application by an adjacent neighbor to purchase a city-owned parcel accompanied by the payment of a non-refundable \$150.00 application fee, the department shall obtain departmental approvals and an appraisal.

For qualifying city-owned parcels, ~~he~~ the department shall give written notice by certified mail to any owner of improved residential adjacent property indicating that the department will accept sealed bids for the parcel for a period of 30 days from the date of the mailing of the notice. All bids which conform to the requirements of A.N.L.A.P. shall be submitted by the department to the city council and shall thereafter be referred to the city council committee having jurisdiction over the disposition of city-owned real estate. The bids shall be promptly placed on the committee's agenda and a public hearing shall be held within a reasonable time thereafter. The city council may accept the higher bid by a majority vote or may reject both bids by a vote of three-quarters of its members. If an adjacent neighbor making an offer to purchase a city-owned parcel is the sole adjacent neighbor or the sole bidder, then the department shall submit the offer to the city council, which shall then be referred to the committee having jurisdiction over the disposition of city-owned real estate. The committee shall promptly consider the offer and then forward its recommendation to the city council. The city council may approve or reject the offer by a majority vote. A successful bidder shall deposit with the city a non-refundable earnest money deposit in an amount equal to not less than ten percent (10%) of the approved offer amount within sixty (60) days of city council approval. Such earnest money deposit shall be retained by the city if the successful bidder does not close the acquisition within six (6) months' of city council approval, or credited towards the purchase price if such closing does occur within such time period.

2-159-060 Covenants in deed – Termination of covenants.

Any deed conveying a parcel to an adjacent neighbor pursuant to the provisions of A.N.L.A.P. shall contain covenants which (1) prohibit the adjacent neighbor from conveying, assigning or otherwise transferring the city-owned parcel except in conjunction with the sale of the adjacent neighbor's parcel on which his primary residence is located ~~owned by the adjacent neighbor~~; and (2) require that the city-owned parcel be improved with landscaped open space within six (6) months of the conveyance of such parcel, and prohibit the construction of any permanent improvements on the parcel, excluding only improvements made by the adjacent neighbor on the parcel that constitute an integrated addition to the adjacent neighbor's primary residence, or a garage appurtenant thereto, and (3) require the adjacent neighbor to maintain the city-owned parcel in accordance with the provisions of the Municipal Code of Chicago. For purposes of this Section, the term "landscaped" shall mean the planting planting and maintenance of lawn grass, or cultivated ornamental shrubs, plants or trees, or a combination thereof. The covenants shall terminate ten (10) years after the date of the conveyance of the city-owned parcel to the adjacent neighbor.

2-159-070 Rules and regulations.

The department may establish rules, regulations and procedures for the advertising, bidding and sale of city-owned parcels pursuant to the provisions of A.N.L.A.P. All such rules, regulations and procedures shall be published and made available by the department.

SECTION 2. This ordinance shall be in full force and effect upon its passage and approval.

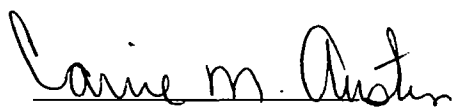
Carrie M. Austin
Alderman, 34th Ward



City of Chicago



O2014-4233

Office of the City Clerk

Document Tracking Sheet

| | |
|---------------------------------|--|
| Meeting Date: | 5/28/2014 |
| Sponsor(s): | Tunney (44) |
| Type: | Ordinance |
| Title: | Amendment of Section 4-64-110 modifying retail tobacco dealer's license issuance or renewal requirements |
| Committee(s) Assignment: | Committee on License and Consumer Protection |

ORDINANCE

License

BE IT ORDAINED BY THE CITY COUNCIL OF THE CITY OF CHICAGO:

SECTION 1. Section 4-64-110 of the Municipal Code of Chicago is hereby amended by inserting the language underscored, as follows:

4-64-110 License – Application – Investigation – License issuance or renewal prohibited when.

(a) *Application.* An application for a retail tobacco dealer's license and a tobacco product sampler's license shall be made in conformity with the general requirements of this Code relating to applications for licenses. In addition to the requirements set forth in Section 4-4-050, if the applicant for a license under this Article II sells, offers for sale, exposes for sale or displays tobacco accessories on the licensed premises, or intends to engage in any such activity on the licensed premises, such application shall be accompanied by the following information:

- (1) (i) the percentage of total shelf space at the licensed location that is or is anticipated to be used to display tobacco accessories; and (ii) the percentage of total sales that is or is anticipated to be derived from the sale of tobacco accessories at the licensed location; and
- (2) a statement as to whether, within ten years of the date of application or renewal, the applicant or any controlling person has ever been convicted, in custody, under parole, or under any other non-custodial supervision resulting from a conviction in a court of competent jurisdiction of a felony of whatever degree under the Illinois Drug Paraphernalia Control Act or its equivalent in another jurisdiction.

(b) *Investigation required.* The commissioner of business affairs and consumer protection shall cause an investigation to be made of the character and the reputation of the applicant, or whether said applicant is a proper person to be entrusted with the sale of cigarettes, and of whether the premises named in said application comply with the provisions of this Code applicable to said business, including the requirement as to location.

(c) *License issuance and renewal prohibited when.* If an applicant for a retail tobacco dealer's license sells, offers for sale, exposes for sale or displays tobacco accessories on the licensed premises, or intends to engage in such activity on the licensed premises, no retail tobacco license to engage in such activity shall be issued to such person if, within ten years of

the date of application or renewal, the applicant or any controlling person has ever been convicted, in custody, under parole, or under any other non-custodial supervision resulting from a conviction in a court of competent jurisdiction of a felony of whatever degree under the Illinois Drug Paraphernalia Control Act or its equivalent in another jurisdiction.

SECTION 2. Article II of Chapter 4-64 of the Municipal Code of Chicago is hereby amended by inserting a new Section 4-64-145, as follows:

4-64-145 Drug Paraphernalia – Prohibited.

It shall be unlawful for any licensee under Article II of this chapter to violate the Illinois Drug Paraphernalia Control Act. A single violation of this section may result in license suspension or revocation in accordance with Section 4-4-280 of this Code.

SECTION 3. This ordinance shall take full force and effect ten days after its passage and publication.

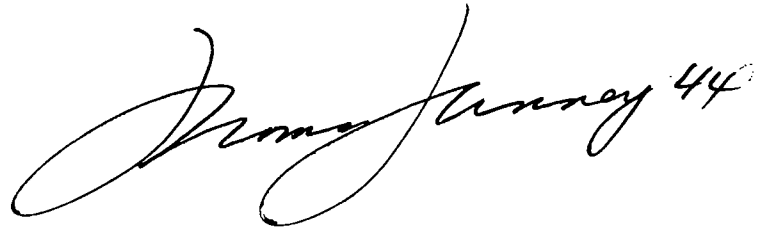
A handwritten signature in black ink, reading "Jerry Jansky 44". The signature is written in a cursive style with a large, looping initial "J".



City of Chicago



O2014-4251

Office of the City Clerk

Document Tracking Sheet

Meeting Date: 5/28/2014

Sponsor(s): Arena (45)
Sawyer (6)
Moreno (1)
Foulkes (15)
Waguespack (32)
Burnett (27)
Holmes (7)
Chandler (24)
Moore (49)
Graham (29)
Lane (18)
Fioretti (2)
Hairston (5)
Munoz (22)
Sposato (36)
Solis (25)
Ervin (28)
Cochran (20)
Colón (35)
Thomas (17)
Maldonado (26)

Type: Ordinance

Title: Amendment of Municipal Code Title 4 by adding new Chapter 4-404 titled "Chicago Minimum Wage"

Committee(s) Assignment: Committee on Workforce Development and Audit

CHICAGO MINIMUM WAGE FOR LARGE EMPLOYERS

DRAFT ORDINANCE

May 28, 2014

*Work
Force*

WHEREAS, the City of Chicago is a home-rule municipality in accordance with the constitution of the State of Illinois of 1970; and

WHEREAS, the city has the authority to adopt ordinances and to promulgate rules and regulations pertaining to its government and affairs in order to protect the health, safety and welfare of its citizens; and

WHEREAS, the city council finds that the growth of low-wage jobs is worsening poverty in Chicago and forcing more working individuals and families to rely on taxpayer-funded programs such as Medicaid, SNAP, and food pantries to make ends meet; and

WHEREAS, the city council finds that the growth of low-wage jobs is also hurting the city's economy, which needs a workforce that can afford to spend to drive economic activity and sustain growth; and

WHEREAS, the city council finds that in particular large employers, such as the city's fast food and retail chains, are some of the top sources of low-wage jobs in the city, despite the fact that many of these companies are highly profitable major corporations; and

WHEREAS, the city council finds that while the state of Illinois is considering raising the state minimum wage, the state is unlikely to raise it to a high enough level to enable low-wage workers to meet their basic needs without relying on taxpayer-funded programs for support; and

WHEREAS, the city council find that because the costs of living and housing in Chicago are much higher than in other parts of Illinois, Chicago needs a higher minimum wage that better reflects the needs of the local workforce and economy; and

WHEREAS, the city council finds that the city of Seattle recently approved phasing its minimum wage up to \$15 and across the country other high-cost cities like New York, Los Angeles and San Francisco are proposing to do the same; and

WHEREAS, city council finds that a \$15 minimum wage would improve the lives of more than 500,000 working Chicagoans, reduce poverty and inequality across the city, and give low-income workers thousands of dollars more each year to meet rising living costs and spend at neighborhood businesses; and

WHEREAS, the city council finds that it is fair to ask employers in the city to do their part by phasing the minimum wage up to \$15; and

WHEREAS, the city council determines that raising the minimum wage to \$15 would promote the public health, safety and welfare, and reduce the burden that low wages are imposing on the taxpayers; now, therefore

BE IT ORDAINED by the city council of the City of Chicago, Cook County, Illinois, that the Municipal Code of the City of Chicago is amended by adding thereto and inserting therein a new chapter 4-404, entitled “Chicago Minimum Wage”:

SECTION 1. The foregoing recitals are incorporated herein as the findings of the city council.

SECTION 2. A new chapter of the Municipal Code of the City of Chicago, titled “Chicago Minimum Wage,” is hereby created as follows:

4-404-010 Definitions.

For the purposes of this chapter, the following definitions shall apply unless the context clearly indicates or requires a different meaning:

- (a) “Airport employer” means any employer that operates at the O’Hare International Airport or Midway Airport.
- (b) “City” means the City of Chicago.
- (c) “Department” means the Department of Business Affairs and Consumer Protection or such other department or entity designated by the mayor to administer this chapter.
- (d) “Employer” shall have the meaning set forth in 820 ILCS 105/3(c); an employer can include more than one entity, including in circumstances in which one entity controls, is controlled by, or is under common control with another employer, and including circumstances in which one entity exerts control over the operations of another employer, but shall not include the city of Chicago.
- (e) “Employee” shall have the meaning set forth in 820 ILCS 105/3(d), provided however that employee shall include any individual permitted to work in domestic service in or about a private home, irrespective of the number of employees employed by that individual’s employer. Employee shall not include (1) any person who in a particular week performs less than two hours of work within the geographic boundaries of the city, or (2) any person who is employed by a not-for-profit organization under a summer youth employment program.
- (f) “Franchisee” means any employer that operates in the city in the restaurant industry under a franchise agreement with a large employer.
- (g) (1) “Large employer” means any employer that has (i) annual gross revenue of \$50 million or more, and (ii) has employees that perform work within the geographic boundaries of the city or has one or more franchisees or on-site contractors with employees that perform work within the geographic boundaries of the city.

(2) An employer shall be deemed to have annual gross revenue of \$50 million or more if it had revenue at or exceeding that level in any of the past three fiscal or calendar years or if it is reasonably expected to have annual revenue equal to or exceeding that level in the current or upcoming fiscal or calendar year.

(3) Large employer shall include any franchisee or on-site contractor of a large employer, or airport employer, regardless of the revenue level of the franchisee or on-site contractor of the large employer, or of the airport employer.

(4) Large employer shall include any nursing home, management company or other organization that qualifies as a related organization under Illinois Department of Healthcare and Family Services long-term care facility cost report guidelines promulgated pursuant to Public Act 81-223 and related statutes so long as the group of related organizations collectively has annual gross revenue of \$50 million or more.

(h) "Minimum Wage" shall have the meaning set forth in section 4-404-020 of this chapter.

(i) "Mid and Small Sized Employer" means any employer that does not qualify as a large employer.

(j) "On-site contractor" means any employer that provides services or labor in the city on premises controlled by a large employer, including, but not limited to, a staffing, temporary services, building services, or food services contractor.

(k) "Retaliation" means any threat, discipline, discharge, demotion, suspension, reduction in employee hours, or any other adverse employment action against any employee for exercising or attempting to exercise any right guaranteed under this chapter.

(l) "Tipped Minimum Wage" shall have the meaning set forth in section 4-404-020(d) of this chapter.

4-404-020 Minimum Wage.

(a) Employers shall pay employees no less than the applicable minimum wage rate provided for in this chapter for each hour worked within the geographic boundaries of the city.

(b) The minimum wage rate shall be an hourly rate as follows:

1. For large employers, the minimum wage rate shall be:

A. Beginning ninety days after the effective date of this chapter, \$12.50 per hour;

B. Beginning one year after the effective date of this chapter, \$15.00 per hour.

2. For mid and small sized employers, the minimum wage rate shall be:

- A. Beginning one year and ninety days after the effective date of this chapter, \$12.00 per hour;
 - B. Beginning two years after the effective date of this chapter, \$13.00 per hour;
 - C. Beginning three years after the effective date of this chapter, \$14.00 per hour;
 - D. Beginning four years after the effective date of this chapter, \$15.00 per hour.
- (c) To prevent inflation from eroding the value of the minimum wage, the current minimum wage rate for large employers and the current minimum wage rate for mid and small sized employers shall each be increased annually in proportion to the increase, if any, in the cost of living. For the minimum wage rate for large employers, such annual increases shall begin on January 1 of the year following the first anniversary of the effective date of this chapter, and take place on each January 1 thereafter. For the minimum wage rate for mid and small sized employers, such annual increases shall begin on January 1 of the year following the fourth anniversary of the effective date of this chapter, and take place on each January 1 thereafter. The increase in the cost of living shall be calculated using the twelve-month percentage increase, if any, in the Consumer Price Index for all Urban Consumers, U.S. City Average, All Items (or a successor index, if any) as published by the Bureau of Labor Statistics of the United States Department of Labor, using the most recent twelve-month period for which data is available at the time that the calculation is made. The increased minimum wage rate shall be rounded to the nearest five cents and announced at least ninety days before the January 1 effective date.
- (d) The tipped minimum wage rate for large employers and the tipped minimum wage rate for mid and small sized employers shall be an amount equal to 70% of the applicable minimum wage rate for each size of employer provided for in subsection b of this chapter, rounded to the nearest five cents. The tipped minimum wage rate for each size of employer shall be adjusted whenever the applicable minimum wage rate for that size employer increases, and the adjusted minimum wage rates for tipped employees shall be announced at least ninety days before the effective date of the adjusted rates. Employers shall pay an employee who customarily and regularly receives tips a cash wage of no less than the tipped minimum wage rate provided for in this subsection for each hour worked within the geographic boundaries of the city, and shall guarantee that at all times the combination of the cash wage paid by the employer and the tips received by the employee total no less than the regular minimum wage rate for each hour worked within the geographic boundaries of the city. Such calculation shall be made based on the total wages and tips received by the employee over the course of his or her shift.

4-404-030 Retaliation Prohibited.

- (a) No employer or other person shall retaliate against any person for asserting any claim or right under this chapter, for assisting any other person in doing so, or for informing any person about his or her rights under this chapter.

4-404-040 Implementation and Enforcement.

- (a) At least sixty days before the effective date of each increase in the minimum wage the department shall publish and make available to employers a bulletin announcing the new minimum wage rate and the minimum wage rate for tipped employees, and a notice, in English and Spanish, informing employees of the updated rates, which all employers shall post in a conspicuous place at any workplace or job site where an employee works.
- (b) Employers shall keep payroll records as provided for under 820 ILCS 105/8.
- (c) Employers shall allow the department access to payroll records to monitor compliance with the requirements of this chapter. Employers shall provide reasonable access to any employee and any employee's designated representative to inspect the employer's payroll pertaining to that employee. Where an employer does not maintain or retain adequate records as required under subsection b of this section, or does not allow the department reasonable access to such records, there shall be a rebuttable presumption that the employer has not paid the required minimum wage.
- (d) The department is authorized to interpret, implement, and enforce this chapter, including by issuing regulations and administrative findings of violations and instituting legal actions to enforce administrative findings. Civil penalties shall be retained by the department and used to finance activities to enforce this chapter. Any regulations, guidelines, or rules promulgated by the department shall have the force and effect of law and may be relied on by employers, employees, and other parties to determine their rights and responsibilities under this chapter.
- (e) An employer that fails to pay the minimum wage required under this chapter shall be required to pay the employee the unpaid compensation together with an additional two times that amount as liquidated damages. An employer that retaliates against an employee in violation of this chapter shall be required to provide equitable relief to the employee, including reinstatement where appropriate, and to pay the employee (1) any unpaid compensation together with an additional two times that amount as liquidated damages for each day from the date of the retaliation until the date that the violation is remedied or (2) \$5,000, whichever is greater.
- (f) Any person or organization may file an administrative complaint with the department charging that a large retail employer has violated this chapter as to any employee or other person. The department shall promptly investigate administrative complaints and may interview and review records regarding any or all employees at the employer's worksite in order to determine whether a pattern of violations has occurred and to protect the identity of any employee identified in the complaint. The name of any employee identified in a complaint shall be kept confidential as long as possible, and may be disclosed only with the employee's consent. Where the department determines that a violation has occurred, the department shall issue an administrative order finding a violation and ordering payment of unpaid compensation, liquidated damages, and civil penalties, and may take any other appropriate enforcement action to secure compliance, including initiating a civil action and/or instructing city agencies or departments to

revoke or suspend any registration certificates, permits or licenses held or requested by the employer or person until such time as the violation is remedied.

- (g) An employee who is underpaid or who suffers retaliation in violation of this chapter may bring an action against an employer in any court of competent jurisdiction and, upon prevailing, shall be awarded any appropriate legal or equitable relief, including unpaid compensation and an additional two times that amount in liquidated damages, reinstatement, actual damages, and civil penalties. An employee need not exhaust administrative remedies before bringing an action nor shall an investigation of an employer by the department or other law enforcement officer bar a person from bringing an action.

4-404-050 Miscellaneous.

- (a) This chapter shall take effect upon enactment.
- (b) This chapter shall be liberally construed in favor of its purposes, and shall not be construed to preempt or otherwise limit the applicability of any law, policy or other provision that provides for payment of higher or supplemental wages or benefits.
- (c) If any part of this chapter, or the application of the chapter to any person or circumstance, is held invalid, the remainder of this chapter, including the application of such part to other persons or circumstances, shall not be affected by such a holding and shall continue in full force and effect. To this end, the parts of this law are severable.

John Arena 45th ward

John Arena 45th ward

Roderick Sawyer 6th ward

Roderick Sawyer 6th ward

Joe Moreno 1st Ward

Joe Moreno 1st Ward

Leslie A. Kavston (5th)

Leslie A. Kavston (5th)

Richard Sparto 36th

Richard Sparto 36th

Wamil Sale 2nd

~~Richard Sparto 36th~~

Richard Sparto 36th

Richard Sparto 36th

Richard Sparto 36th

Richard Sparto 36th

Richard Sparto 36th

Richard Sparto 36th

John A. Moreno 15th

John A. Moreno 15th

John A. Moreno 15th

John A. Moreno 15th

John A. Moreno 15th

John A. Moreno 15th

John A. Moreno 15th

John A. Moreno 15th

... ..

... ..

... ..

... ..

... ..

... ..

... ..

... ..

... ..

... ..

... ..



City of Chicago



O2014-4234

Office of the City Clerk

Document Tracking Sheet

| | |
|---------------------------------|--|
| Meeting Date: | 5/28/2014 |
| Sponsor(s): | Pawar (47) |
| Type: | Ordinance |
| Title: | Amendment of Municipal Code Section 4-6-230(g)(5) concerning booting of motor vehicles within 47th Ward |
| Committee(s) Assignment: | Committee on License and Consumer Protection |

ORDINANCE

BE IT ORDAINED BY THE CITY COUNCIL OF THE CITY OF CHICAGO:

SECTION 1. Section 4-6-230 (g) (5) of the Municipal code of Chicago is hereby amended by adding the underscored text as follows:

4-6-230 Booting of motor vehicles.

(a) Definitions. As used in this section:

“Boot” or “booting” means the act of placing on a parked motor vehicle any mechanical device that is designed to be attached to a wheel or tire or other part of such vehicle so as to prohibit the vehicle’s usual manner of movement.

“Motor vehicle” means every vehicle which is propelled by a motor.

(Omitted text is unaffected by this ordinance)

(g) Prohibited acts. It shall be unlawful for any licensee engaged in the business of booting motor vehicles to:

- (1) Provide booting services at any property at which any person having a beneficial interest in the licensee also has a beneficial interest in the subject property;
- (2) Place a boot upon any occupied motor vehicle or upon any motor vehicle parked in accordance with the terms of use for the subject property;
- (3) Assess a fee in excess of \$140.00 to remove a boot;
- (4) Use any boot of a color prohibited by the commissioner in duly promulgated rules and regulations. The commissioner may prohibit any color which might be confused with a boot used by the City as a part of the City’s vehicle immobilization program; and
- (5) Engage in booting operations at any location that is outside the 1st Ward, 12th Ward, 15th Ward, 21st Ward, 22nd Ward, 23rd Ward, 25th Ward, 26th Ward, 27th Ward, 30th Ward, 32nd Ward, 33rd Ward, 34th Ward, 36th Ward, 37th Ward, 38th Ward, 40th Ward, 42nd Ward, 43rd Ward, 44th Ward, 45th Ward, 46th Ward, 47th Ward, 48th Ward, or 49th Ward.

SECTION 2. This ordinance shall be in full force and effect from and after its passage and publication.



Ameya Pawar
Alderman, 47th Ward



City of Chicago



O2014-4277

Office of the City Clerk

Document Tracking Sheet

| | |
|---------------------------------|--|
| Meeting Date: | 5/28/2014 |
| Sponsor(s): | Moreno (1) |
| Type: | Ordinance |
| Title: | Sidewalk cafe(s) for Craft Pizza |
| Committee(s) Assignment: | Committee on Transportation and Public Way |

ORDINANCE
Craft Pizza
Acct. No. 390040 - 1
Permit No. 1113286

Be It Ordained by the City Council of the City of Chicago:

Permission and authority are hereby given and granted to Craft Pizza upon the terms and subject to the conditions of this ordinance, to maintain and use a portion of the public right of way for a sidewalk cafe adjacent to its premises located at 1252 N. Damen Ave.. Said sidewalk cafe area #1 shall be thirty-seven (37) feet in length and eleven (11) feet in width for a total of four hundred seven (407) square feet and shall allow six (6) feet of clear space from the face of the curb/building line along W. Potomac. The compensation for said space and the days and hours of operation for the sidewalk cafe shall be as follows:

Sunday through Thursday 8:00 a.m. to 10:00 p.m. Friday and Saturday 8:00 a.m. to 11:00 p.m.

Compensation: \$600.00

SEATING CAPACITY: 36

Sidewalk Cafe Permit and approved plan must be posted at all times.

This grant of privilege #1113286 for a sidewalk cafe shall be subject to the provisions of Section 10-28-800 through 10-28-885 of the Municipal Code of Chicago and the directions of the Commissioner of Department of Business Affairs and Consumer Protection, the Commissioner of Streets and Sanitation, and the Commissioner of Transportation.

The permit holder agrees to hold the City of Chicago harmless for any damage, relocation or replacement costs associated with damage, relocation or removal of private property caused by the City performing work in the public way.

Authority for the above named privilege is herein given and granted from and after March 1, 2014 through and including December 1, 2014.

Alderman



Proco Joe Moreno 1st Ward



05/28/2014

Alderman Proco Joe Moreno
Ward # **01**
City of Chicago
City Hall, Room **300**
121 North LaSalle Street
Chicago, Illinois 60602

Re: An ordinance to use and maintain a portion of the public right-of-way for **one (1) sidewalk cafe(s)** for **Craft Pizza**, adjacent to the premises known as **1252 N. Damen Ave.**.

Dear Alderman **Proco Joe Moreno**:

The applicant referenced above has requested the use of the public right-of-way for a **sidewalk cafe(s)**. An ordinance has been prepared by the Department of Business Affairs and Consumer Protection – Small Business Center - Public Way Use Unit for presentation to the City Council. Because this request was made for properties located in your ward, as approved by you as per the attached, I respectfully request that you introduce the attached ordinance at the next City Council meeting.

If you have any questions regarding this ordinance, please contact Anthony Bertuca at (312) 744-5506.

Department of Business Affairs and Consumer Protection



City of Chicago



O2014-4279

Office of the City Clerk
Document Tracking Sheet

| | |
|---------------------------------|--|
| Meeting Date: | 5/28/2014 |
| Sponsor(s): | Moreno (1) |
| Type: | Ordinance |
| Title: | Sidewalk cafe(s) for Hash |
| Committee(s) Assignment: | Committee on Transportation and Public Way |

ORDINANCE

Hash

Acct. No. 377028 - 1

Permit No. 1113057

Be It Ordained by the City Council of the City of Chicago:

Permission and authority are hereby given and granted to Hash upon the terms and subject to the conditions of this ordinance, to maintain and use a portion of the public right of way for a sidewalk cafe adjacent to its premises located at 1357 N. Western Ave.. Said sidewalk cafe area #1 shall be thirty-one point three three (31.33) feet in length and ten point five (10.5) feet in width for a total of three hundred twenty-eight point nine seven (328.97) square feet and shall allow six (6) feet of clear space from the face of the curb/building line along W. Hirsch. The compensation for said space and the days and hours of operation for the sidewalk cafe shall be as follows:

Wednesday through Monday 8:00 a.m. to 12:00 midnight

Compensation: \$600.00

SEATING CAPACITY: 24

Sidewalk Cafe Permit and approved plan must be posted at all times.

This grant of privilege #1113057 for a sidewalk cafe shall be subject to the provisions of Section 10-28-800 through 10-28-885 of the Municipal Code of Chicago and the directions of the Commissioner of Department of Business Affairs and Consumer Protection, the Commissioner of Streets and Sanitation, and the Commissioner of Transportation.

The permit holder agrees to hold the City of Chicago harmless for any damage, relocation or replacement costs associated with damage, relocation or removal of private property caused by the City performing work in the public way.

Authority for the above named privilege is herein given and granted from and after March 1, 2014 through and including December 1, 2014.

Alderman _____

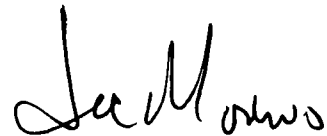

Proco Joe Moreno 1st Ward



05/28/2014

Alderman **Proco Joe Moreno**
Ward # **01**
City of Chicago
City Hall, Room **300**
121 North LaSalle Street
Chicago, Illinois 60602

Re: An ordinance to use and maintain a portion of the public right-of-way for **one (1) sidewalk cafe(s)** for **Hash**, adjacent to the premises known as **1357 N. Western Ave.**.

Dear Alderman **Proco Joe Moreno**:

The applicant referenced above has requested the use of the public right-of-way for a **sidewalk cafe(s)**. An ordinance has been prepared by the Department of Business Affairs and Consumer Protection – Small Business Center - Public Way Use Unit for presentation to the City Council. Because this request was made for properties located in your ward, as approved by you as per the attached, I respectfully request that you introduce the attached ordinance at the next City Council meeting.

If you have any questions regarding this ordinance, please contact Anthony Bertuca at (312) 744-5506.

Department of Business Affairs and Consumer Protection



City of Chicago



O2014-4281

Office of the City Clerk

Document Tracking Sheet

| | |
|---------------------------------|---|
| Meeting Date: | 5/28/2014 |
| Sponsor(s): | Moreno (1) |
| Type: | Ordinance |
| Title: | Sidewalk cafe(s) for Koko's Mediterranean Grill |
| Committee(s) Assignment: | Committee on Transportation and Public Way |

ORDINANCE
KOKO'S MEDITERRANEAN GRILL
Acct. No. 385744 - 1
Permit No. 1112918

Be It Ordained by the City Council of the City of Chicago:

Permission and authority are hereby given and granted to KOKO'S MEDITERRANEAN GRILL upon the terms and subject to the conditions of this ordinance, to maintain and use a portion of the public right of way for a sidewalk cafe adjacent to its premises located at 1760 W. Chicago Ave.. Said sidewalk cafe area #1 shall be sixty-three (63) feet in length and six (6) feet in width for a total of three hundred seventy-eight (378) square feet and shall allow six (6) feet of clear space from the face of the curb/building line along N. Wood Street. The compensation for said space and the days and hours of operation for the sidewalk cafe shall be as follows:

Monday through Saturday 8:00 a.m. to 12:00 midnight Sunday 8:00 a.m. to 10:00 p.m.
Compensation: \$600.00
SEATING CAPACITY: 28

Sidewalk Cafe Permit and approved plan must be posted at all times.

This grant of privilege #1112918 for a sidewalk cafe shall be subject to the provisions of Section 10-28-800 through 10-28-885 of the Municipal Code of Chicago and the directions of the Commissioner of Department of Business Affairs and Consumer Protection, the Commissioner of Streets and Sanitation, and the Commissioner of Transportation.

The permit holder agrees to hold the City of Chicago harmless for any damage, relocation or replacement costs associated with damage, relocation or removal of private property caused by the City performing work in the public way.

Authority for the above named privilege is herein given and granted from and after March 1, 2014 through and including December 1, 2014.

Alderman _____

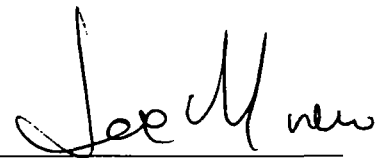

Proco Joe Moreno 1st Ward



05/28/2014

Alderman **Proco Joe Moreno**
Ward # 01
City of Chicago
City Hall, Room 300
121 North LaSalle Street
Chicago, Illinois 60602

Re: An ordinance to use and maintain a portion of the public right-of-way for **one (1) sidewalk cafe(s)** for **KOKO'S MEDITERRANEAN GRILL**, adjacent to the premises known as **1760 W. Chicago Ave.**.

Dear Alderman **Proco Joe Moreno**:

The applicant referenced above has requested the use of the public right-of-way for a **sidewalk cafe(s)**. An ordinance has been prepared by the Department of Business Affairs and Consumer Protection – Small Business Center - Public Way Use Unit for presentation to the City Council. Because this request was made for properties located in your ward, as approved by you as per the attached, I respectfully request that you introduce the attached ordinance at the next City Council meeting.

If you have any questions regarding this ordinance, please contact Anthony Bertuca at (312) 744-5506.

Department of Business Affairs and Consumer Protection



City of Chicago



O2014-4286

Office of the City Clerk

Document Tracking Sheet

| | |
|---------------------------------|--|
| Meeting Date: | 5/28/2014 |
| Sponsor(s): | Moreno (1) |
| Type: | Ordinance |
| Title: | Sidewalk cafe(s) for La Strade Cafe |
| Committee(s) Assignment: | Committee on Transportation and Public Way |

ORDINANCE
LA STRADA CAFE
Acct. No. 383292 - 1
Permit No. 1113264

Be It Ordained by the City Council of the City of Chicago:

Permission and authority are hereby given and granted to LA STRADA CAFE upon the terms and subject to the conditions of this ordinance, to maintain and use a portion of the public right of way for a sidewalk cafe adjacent to its premises located at 2023 N. California Ave.. Said sidewalk cafe area #1 shall be eleven (11) feet in length and five (5) feet in width for a total of fifty-five (55) square feet and shall allow six (6) feet of clear space from the face of the curb/building line along N. California Avenue. The compensation for said space and the days and hours of operation for the sidewalk cafe shall be as follows:

Monday through Friday 8:00 a.m. to 7:00 p.m. Saturday and Sunday 8:00 a.m. to 5:00 p.m.
Compensation: \$600.00
SEATING CAPACITY: 16

Sidewalk Cafe Permit and approved plan must be posted at all times.

This grant of privilege #1113264 for a sidewalk cafe shall be subject to the provisions of Section 10-28-800 through 10-28-885 of the Municipal Code of Chicago and the directions of the Commissioner of Department of Business Affairs and Consumer Protection, the Commissioner of Streets and Sanitation, and the Commissioner of Transportation.

The permit holder agrees to hold the City of Chicago harmless for any damage, relocation or replacement costs associated with damage, relocation or removal of private property caused by the City performing work in the public way.

Authority for the above named privilege is herein given and granted from and after March 1, 2014 through and including December 1, 2014.

Alderman _____



Proco Joe Moreno 1st Ward



05/28/2014

Alderman **Proco Joe Moreno**
Ward # **01**
City of Chicago
City Hall, Room **300**
121 North LaSalle Street
Chicago, Illinois 60602

Re: An ordinance to use and maintain a portion of the public right-of-way for **one (1) sidewalk cafe(s)** for **LA STRADA CAFE**, adjacent to the premises known as **2023 N. California Ave.**.

Dear Alderman **Proco Joe Moreno**:

The applicant referenced above has requested the use of the public right-of-way for a **sidewalk cafe(s)**. An ordinance has been prepared by the Department of Business Affairs and Consumer Protection – Small Business Center - Public Way Use Unit for presentation to the City Council. Because this request was made for properties located in your ward, as approved by you as per the attached, I respectfully request that you introduce the attached ordinance at the next City Council meeting.

If you have any questions regarding this ordinance, please contact Anthony Bertuca at (312) 744-5506.

Department of Business Affairs and Consumer Protection



City of Chicago



O2014-4291

Office of the City Clerk

Document Tracking Sheet

| | |
|---------------------------------|--|
| Meeting Date: | 5/28/2014 |
| Sponsor(s): | Moreno (1) |
| Type: | Ordinance |
| Title: | Sidewalk cafe(s) for Las Islas Marias |
| Committee(s) Assignment: | Committee on Transportation and Public Way |

ORDINANCE
LAS ISLAS MARIAS
Acct. No. 293315 - 2
Permit No. 1113160

Be It Ordained by the City Council of the City of Chicago:

Permission and authority are hereby given and granted to LAS ISLAS MARIAS upon the terms and subject to the conditions of this ordinance, to maintain and use a portion of the public right of way for a sidewalk cafe adjacent to its premises located at 2043-51 N. Milwaukee Ave.. Said sidewalk cafe area #1 shall be sixty-six point seven (66.7) feet in length and six point two (6.2) feet in width for a total of four hundred thirteen point five four (413.54) square feet and shall allow six (6) feet of clear space from the face of the curb/building line along N. Milwaukee Avenue. The compensation for said space and the days and hours of operation for the sidewalk cafe shall be as follows:

Monday and Tuesday 12:00 noon to 10:00 p.m. Wednesday and Thursday 12:00 noon to 12:00 midnight Friday through Sunday 9:00 a.m. to 12:00 midnight
Compensation: \$600.00
SEATING CAPACITY: 40

Sidewalk Cafe Permit and approved plan must be posted at all times.

This grant of privilege #1113160 for a sidewalk cafe shall be subject to the provisions of Section 10-28-800 through 10-28-885 of the Municipal Code of Chicago and the directions of the Commissioner of Department of Business Affairs and Consumer Protection, the Commissioner of Streets and Sanitation, and the Commissioner of Transportation.

The permit holder agrees to hold the City of Chicago harmless for any damage, relocation or replacement costs associated with damage, relocation or removal of private property caused by the City performing work in the public way.

Authority for the above named privilege is herein given and granted from and after March 1, 2014 through and including December 1, 2014.

Alderman _____



Proco Joe Moreno 1st Ward



05/28/2014

Alderman **Proco Joe Moreno**
Ward # **01**
City of Chicago
City Hall, Room **300**
121 North LaSalle Street
Chicago, Illinois 60602

Re: An ordinance to use and maintain a portion of the public right-of-way for **one (1) sidewalk cafe(s)** for **LAS ISLAS MARIAS**, adjacent to the premises known as **2043-51 N. Milwaukee Ave.**.

Dear Alderman **Proco Joe Moreno**:

The applicant referenced above has requested the use of the public right-of-way for a **sidewalk cafe(s)**. An ordinance has been prepared by the Department of Business Affairs and Consumer Protection – Small Business Center - Public Way Use Unit for presentation to the City Council. Because this request was made for properties located in your ward, as approved by you as per the attached, I respectfully request that you introduce the attached ordinance at the next City Council meeting.

If you have any questions regarding this ordinance, please contact Anthony Bertuca at (312) 744-5506.

Department of Business Affairs and Consumer Protection



City of Chicago



O2014-4305

Office of the City Clerk

Document Tracking Sheet

| | |
|---------------------------------|--|
| Meeting Date: | 5/28/2014 |
| Sponsor(s): | Moreno (1) |
| Type: | Ordinance |
| Title: | Sidewalk cafe(s) for Mexique |
| Committee(s) Assignment: | Committee on Transportation and Public Way |

ORDINANCE
MEXIQUE
Acct. No. 314785 - 1
Permit No. 1113265

Be It Ordained by the City Council of the City of Chicago:

Permission and authority are hereby given and granted to MEXIQUE upon the terms and subject to the conditions of this ordinance, to maintain and use a portion of the public right of way for a sidewalk cafe adjacent to its premises located at 1529 W. Chicago Ave.. Said sidewalk cafe area #1 shall be twenty-four (24) feet in length and four point eight eight (4.88) feet in width for a total of one hundred seventeen point one two (117.12) square feet and shall allow six (6) feet of clear space from the face of the curb/building line along W. Chicago Avenue. The compensation for said space and the days and hours of operation for the sidewalk cafe shall be as follows:

Tuesday through Thursday 11:00 a.m. to 10:00 p.m. Friday 11:00 a.m. to 11:00p.m.
Saturday 10:00 a.m. to 11:00 p.m. Sunday 10:00 a.m. to 9:00 p.m.
Compensation: \$600.00
SEATING CAPACITY: 22

Sidewalk Cafe Permit and approved plan must be posted at all times.

This grant of privilege #1113265 for a sidewalk cafe shall be subject to the provisions of Section 10-28-800 through 10-28-885 of the Municipal Code of Chicago and the directions of the Commissioner of Department of Business Affairs and Consumer Protection, the Commissioner of Streets and Sanitation, and the Commissioner of Transportation.

The permit holder agrees to hold the City of Chicago harmless for any damage, relocation or replacement costs associated with damage, relocation or removal of private property caused by the City performing work in the public way.

Authority for the above named privilege is herein given and granted from and after March 1, 2014 through and including December 1, 2014.

Alderman _____



Proco Joe Moreno 1st Ward



05/28/2014

Alderman **Proco Joe Moreno**
Ward # **01**
City of Chicago
City Hall, Room **300**
121 North LaSalle Street
Chicago, Illinois 60602

Re: An ordinance to use and maintain a portion of the public right-of-way for **one (1) sidewalk cafe(s)** for **MEXIQUE**, adjacent to the premises known as **1529 W. Chicago Ave.**.

Dear Alderman **Proco Joe Moreno**:

The applicant referenced above has requested the use of the public right-of-way for a **sidewalk cafe(s)**. An ordinance has been prepared by the Department of Business Affairs and Consumer Protection – Small Business Center - Public Way Use Unit for presentation to the City Council. Because this request was made for properties located in your ward, as approved by you as per the attached, I respectfully request that you introduce the attached ordinance at the next City Council meeting.

If you have any questions regarding this ordinance, please contact Anthony Bertuca at (312) 744-5506.

Department of Business Affairs and Consumer Protection



City of Chicago



O2014-4312

Office of the City Clerk

Document Tracking Sheet

| | |
|---------------------------------|--|
| Meeting Date: | 5/28/2014 |
| Sponsor(s): | Moreno (1) |
| Type: | Ordinance |
| Title: | Sidewalk cafe(s) for Runa Japanese |
| Committee(s) Assignment: | Committee on Transportation and Public Way |

ORDINANCE
Runa Japanese
Acct. No. 384063 - 1
Permit No. 1113292

Be It Ordained by the City Council of the City of Chicago:

Permission and authority are hereby given and granted to Runa Japanese upon the terms and subject to the conditions of this ordinance, to maintain and use a portion of the public right of way for a sidewalk cafe adjacent to its premises located at 2257 W. North Ave.. Said sidewalk cafe area #1 shall be twenty (20) feet in length and two point one seven (2.17) feet in width, area #2 shall be thirty (30) feet in length and two point one seven (2.17) feet in width for a total of one hundred eight point five (108.5) square feet and shall allow six (6) feet of clear space from the face of the curb/building line along Oakley. The compensation for said space and the days and hours of operation for the sidewalk cafe shall be as follows:

Monday - Sunday 11:30 am to 11:00 pm
Compensation: \$600.00
SEATING CAPACITY: 16

Sidewalk Cafe Permit and approved plan must be posted at all times.

This grant of privilege #1113292 for a sidewalk cafe shall be subject to the provisions of Section 10-28-800 through 10-28-885 of the Municipal Code of Chicago and the directions of the Commissioner of Department of Business Affairs and Consumer Protection, the Commissioner of Streets and Sanitation, and the Commissioner of Transportation.

The permit holder agrees to hold the City of Chicago harmless for any damage, relocation or replacement costs associated with damage, relocation or removal of private property caused by the City performing work in the public way.

Authority for the above named privilege is herein given and granted from and after March 1, 2014 through and including December 1, 2014.

Alderman _____



Proco Joe Moreno 1st Ward



05/28/2014

Alderman **Proco Joe Moreno**
Ward # **01**
City of Chicago
City Hall, Room **300**
121 North LaSalle Street
Chicago, Illinois 60602

Re: An ordinance to use and maintain a portion of the public right-of-way for **two (2) sidewalk cafe(s)** for **Runa Japanese**, adjacent to the premises known as **2257 W. North Ave.**.

Dear Alderman **Proco Joe Moreno**:

The applicant referenced above has requested the use of the public right-of-way for a **sidewalk cafe(s)**. An ordinance has been prepared by the Department of Business Affairs and Consumer Protection – Small Business Center - Public Way Use Unit for presentation to the City Council. Because this request was made for properties located in your ward, as approved by you as per the attached, I respectfully request that you introduce the attached ordinance at the next City Council meeting.

If you have any questions regarding this ordinance, please contact Anthony Bertuca at (312) 744-5506.

Department of Business Affairs and Consumer Protection



City of Chicago



O2014-4316

Office of the City Clerk

Document Tracking Sheet

| | |
|---------------------------------|--|
| Meeting Date: | 5/28/2014 |
| Sponsor(s): | Moreno (1) |
| Type: | Ordinance |
| Title: | Sidewalk cafe(s) for Shambles Bar |
| Committee(s) Assignment: | Committee on Transportation and Public Way |

ORDINANCE
SHAMBLES BAR
Acct. No. 262299 - 2
Permit No. 1113164

Be It Ordained by the City Council of the City of Chicago:

Permission and authority are hereby given and granted to SHAMBLES BAR upon the terms and subject to the conditions of this ordinance, to maintain and use a portion of the public right of way for a sidewalk cafe adjacent to its premises located at 2050 W. Division St.. Said sidewalk cafe area #1 shall be twenty-five (25) feet in length and sixteen point five (16.5) feet in width for a total of four hundred twelve point five (412.5) square feet and shall allow six (6) feet of clear space from the face of the curb/building line along W. Division St.. The compensation for said space and the days and hours of operation for the sidewalk cafe shall be as follows:

Monday through Sunday 11:00 a.m. until 12:00 Midnight
Compensation: \$600.00
SEATING CAPACITY: 25

Sidewalk Cafe Permit and approved plan must be posted at all times.

This grant of privilege #1113164 for a sidewalk cafe shall be subject to the provisions of Section 10-28-800 through 10-28-885 of the Municipal Code of Chicago and the directions of the Commissioner of Department of Business Affairs and Consumer Protection, the Commissioner of Streets and Sanitation, and the Commissioner of Transportation.

The permit holder agrees to hold the City of Chicago harmless for any damage, relocation or replacement costs associated with damage, relocation or removal of private property caused by the City performing work in the public way.

Authority for the above named privilege is herein given and granted from and after March 1, 2014 through and including December 1, 2014.

Alderman _____



Proco Joe Moreno 1st Ward



05/28/2014

Alderman **Proco Joe Moreno**
Ward # **01**
City of Chicago
City Hall, Room **300**
121 North LaSalle Street
Chicago, Illinois 60602

Re: An ordinance to use and maintain a portion of the public right-of-way for **one (1) sidewalk cafe(s)** for **SHAMBLES BAR**, adjacent to the premises known as **2050 W. Division St.**

Dear Alderman **Proco Joe Moreno**:

The applicant referenced above has requested the use of the public right-of-way for a **sidewalk cafe(s)**. An ordinance has been prepared by the Department of Business Affairs and Consumer Protection – Small Business Center - Public Way Use Unit for presentation to the City Council. Because this request was made for properties located in your ward, as approved by you as per the attached, I respectfully request that you introduce the attached ordinance at the next City Council meeting.

If you have any questions regarding this ordinance, please contact Anthony Bertuca at (312) 744-5506.

Department of Business Affairs and Consumer Protection



City of Chicago



O2014-4319

Office of the City Clerk

Document Tracking Sheet

| | |
|---------------------------------|--|
| Meeting Date: | 5/28/2014 |
| Sponsor(s): | Moreno (1) |
| Type: | Ordinance |
| Title: | Sidewalk cafe(s) for Xoco |
| Committee(s) Assignment: | Committee on Transportation and Public Way |

ORDINANCE
XOCO
Acct. No. 386928- 1
Permit No. 1112805

Be It Ordained by the City Council of the City of Chicago:

Permission and authority are hereby given and granted to XOCO upon the terms and subject to the conditions of this ordinance, to maintain and use a portion of the public right of way for a sidewalk cafe adjacent to its premises located at 1471 N. Milwaukee Ave.. Said sidewalk cafe area #1 shall be seventy-four point nine four (74.94) feet in length and nine point five (9.5) feet in width for a total of seven hundred eleven point nine three (711.93) square feet and shall allow six (6) feet of clear space from the face of the curb/building line along Honore Street and Milwaukee Avenue. The compensation for said space and the days and hours of operation for the sidewalk cafe shall be as follows:

Tuesday through Thursday 11:00 a.m. to 10:00 p.m. Friday 11:00 a.m. to 11:00 p.m.
Saturday 8:00 a.m. to 11:00 p.m. Sunday 8:00 a.m. to 8:00 p.m.
Compensation: \$783.12
SEATING CAPACITY: 36

Sidewalk Cafe Permit and approved plan must be posted at all times.

This grant of privilege #1112805 for a sidewalk cafe shall be subject to the provisions of Section 10-28-800 through 10-28-885 of the Municipal Code of Chicago and the directions of the Commissioner of Department of Business Affairs and Consumer Protection, the Commissioner of Streets and Sanitation, and the Commissioner of Transportation.

The permit holder agrees to hold the City of Chicago harmless for any damage, relocation or replacement costs associated with damage, relocation or removal of private property caused by the City performing work in the public way.

Authority for the above named privilege is herein given and granted from and after March 1, 2014 through and including December 1, 2014.

Alderman _____



Proco Joe Moreno 1st Ward



05/28/2014

Alderman Proco Joe Moreno
Ward # 01
City of Chicago
City Hall, Room 300
121 North LaSalle Street
Chicago, Illinois 60602

Re: An ordinance to use and maintain a portion of the public right-of-way for **one (1) sidewalk cafe(s)** for **XOCO**, adjacent to the premises known as **1471 N. Milwaukee Ave.**

Dear Alderman **Proco Joe Moreno**:

The applicant referenced above has requested the use of the public right-of-way for a **sidewalk cafe(s)**. An ordinance has been prepared by the Department of Business Affairs and Consumer Protection – Small Business Center - Public Way Use Unit for presentation to the City Council. Because this request was made for properties located in your ward, as approved by you as per the attached, I respectfully request that you introduce the attached ordinance at the next City Council meeting.

If you have any questions regarding this ordinance, please contact Anthony Bertuca at (312) 744-5506.

Department of Business Affairs and Consumer Protection



City of Chicago



O2014-4323

Office of the City Clerk

Document Tracking Sheet

| | |
|---------------------------------|--|
| Meeting Date: | 5/28/2014 |
| Sponsor(s): | Fioretti (2) |
| Type: | Ordinance |
| Title: | Sidewalk cafe(s) for Giordano's Restaurant |
| Committee(s) Assignment: | Committee on Transportation and Public Way |

ORDINANCE
GIORDANO'S RESTAURANT
Acct. No. 375298 - 1
Permit No. 1113058

Be It Ordained by the City Council of the City of Chicago:

Permission and authority are hereby given and granted to GIORDANO'S RESTAURANT upon the terms and subject to the conditions of this ordinance, to maintain and use a portion of the public right of way for a sidewalk cafe adjacent to its premises located at 1340 S. Michigan Ave.. Said sidewalk cafe area #1 shall be thirty-two point five (32.5) feet in length and six point five (6.5) feet in width for a total of two hundred eleven point two five (211.25) square feet and shall allow six (6) feet of clear space from the face of the curb/building line along S. Michigan Avenue. The compensation for said space and the days and hours of operation for the sidewalk cafe shall be as follows:

Monday through Sunday 11:00 a.m. to 12:00 midnight
Compensation: \$600.00
SEATING CAPACITY: 21

Sidewalk Cafe Permit and approved plan must be posted at all times.

This grant of privilege #1113058 for a sidewalk cafe shall be subject to the provisions of Section 10-28-800 through 10-28-885 of the Municipal Code of Chicago and the directions of the Commissioner of Department of Business Affairs and Consumer Protection, the Commissioner of Streets and Sanitation, and the Commissioner of Transportation.

The permit holder agrees to hold the City of Chicago harmless for any damage, relocation or replacement costs associated with damage, relocation or removal of private property caused by the City performing work in the public way.

Authority for the above named privilege is herein given and granted from and after March 1, 2014 through and including December 1, 2014.

Alderman 
Bob Fioretti 2nd Ward



05/28/2014

Alderman **Bob Fioretti**
Ward # **02**
City of Chicago
City Hall, Room **300**
121 North LaSalle Street
Chicago, Illinois 60602

Re: An ordinance to use and maintain a portion of the public right-of-way for **one (1) sidewalk cafe(s)** for **GIORDANO'S RESTAURANT**, adjacent to the premises known as **1340 S. Michigan Ave.**.

Dear Alderman **Bob Fioretti**:

The applicant referenced above has requested the use of the public right-of-way for a **sidewalk cafe(s)**. An ordinance has been prepared by the Department of Business Affairs and Consumer Protection – Small Business Center - Public Way Use Unit for presentation to the City Council. Because this request was made for properties located in your ward, as approved by you as per the attached, I respectfully request that you introduce the attached ordinance at the next City Council meeting.

If you have any questions regarding this ordinance, please contact Anthony Bertuca at (312) 744-5506.

Department of Business Affairs and Consumer Protection



City of Chicago



O2014-4326

Office of the City Clerk

Document Tracking Sheet

| | |
|---------------------------------|--|
| Meeting Date: | 5/28/2014 |
| Sponsor(s): | Fioretti (2) |
| Type: | Ordinance |
| Title: | Sidewalk cafe(s) for Meli Cafe On Dearborn |
| Committee(s) Assignment: | Committee on Transportation and Public Way |

ORDINANCE
MELI CAFE ON DEARBORN
Acct. No. 383096 - 1
Permit No. 1113064

Be It Ordained by the City Council of the City of Chicago:

Permission and authority are hereby given and granted to MELI CAFE ON DEARBORN upon the terms and subject to the conditions of this ordinance, to maintain and use a portion of the public right of way for a sidewalk cafe adjacent to its premises located at 500 S. Dearborn St.. Said sidewalk cafe area #1 shall be forty-seven point five eight (47.58) feet in length and eight point three three (8.33) feet in width for a total of three hundred ninety-six point three four (396.34) square feet and shall allow six (6) feet of clear space from the face of the curb/building line along S. Dearborn Street. The compensation for said space and the days and hours of operation for the sidewalk cafe shall be as follows:

Monday through Sunday 8:00 a.m. to 11:00 p.m.
Compensation: \$713.41
SEATING CAPACITY: 31

Sidewalk Cafe Permit and approved plan must be posted at all times.

This grant of privilege #1113064 for a sidewalk cafe shall be subject to the provisions of Section 10-28-800 through 10-28-885 of the Municipal Code of Chicago and the directions of the Commissioner of Department of Business Affairs and Consumer Protection, the Commissioner of Streets and Sanitation, and the Commissioner of Transportation.

The permit holder agrees to hold the City of Chicago harmless for any damage, relocation or replacement costs associated with damage, relocation or removal of private property caused by the City performing work in the public way.

Authority for the above named privilege is herein given and granted from and after March 1, 2014 through and including December 1, 2014.

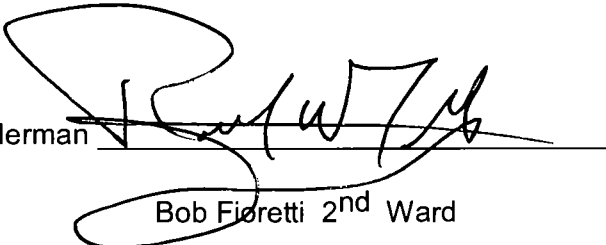
Alderman 
Bob Fioretti 2nd Ward



05/28/2014

Alderman **Bob Fioretti**
Ward # **02**
City of Chicago
City Hall, Room **300**
121 North LaSalle Street
Chicago, Illinois 60602

Re: An ordinance to use and maintain a portion of the public right-of-way for **one (1) sidewalk cafe(s)** for **MELI CAFE ON DEARBORN**, adjacent to the premises known as **500 S. Dearborn St.**

Dear Alderman **Bob Fioretti**:

The applicant referenced above has requested the use of the public right-of-way for a **sidewalk cafe(s)**. An ordinance has been prepared by the Department of Business Affairs and Consumer Protection – Small Business Center - Public Way Use Unit for presentation to the City Council. Because this request was made for properties located in your ward, as approved by you as per the attached, I respectfully request that you introduce the attached ordinance at the next City Council meeting.

If you have any questions regarding this ordinance, please contact Anthony Bertuca at (312) 744-5506.

Department of Business Affairs and Consumer Protection



City of Chicago



O2014-4338

Office of the City Clerk

Document Tracking Sheet

| | |
|---------------------------------|--|
| Meeting Date: | 5/28/2014 |
| Sponsor(s): | Fioretti (2) |
| Type: | Ordinance |
| Title: | Sidewalk cafe(s) for Al's Beef |
| Committee(s) Assignment: | Committee on Transportation and Public Way |

ORDINANCE
Al's Beef
Acct. No. 350032 - 1
Permit No. 1113296

Be It Ordained by the City Council of the City of Chicago:

Permission and authority are hereby given and granted to Al's Beef upon the terms and subject to the conditions of this ordinance, to maintain and use a portion of the public right of way for a sidewalk cafe adjacent to its premises located at 601 W. Adams St.. Said sidewalk cafe area #1 shall be twenty-seven (27) feet in length and ten (10) feet in width, area #2 shall be sixteen (16) feet in length and ten (10) feet in width for a total of four hundred thirty (430) square feet and shall allow six (6) feet of clear space from the face of the curb/building line along Jefferson St. The compensation for said space and the days and hours of operation for the sidewalk cafe shall be as follows:

Monday through Friday 10:00 a.m. until 8:00 p.m. Saturday and Sunday 10:00 a.m. to 6:00 p.m.
Compensation: \$600.00
SEATING CAPACITY: 24

Sidewalk Cafe Permit and approved plan must be posted at all times.

This grant of privilege #1113296 for a sidewalk cafe shall be subject to the provisions of Section 10-28-800 through 10-28-885 of the Municipal Code of Chicago and the directions of the Commissioner of Department of Business Affairs and Consumer Protection, the Commissioner of Streets and Sanitation, and the Commissioner of Transportation.

The permit holder agrees to hold the City of Chicago harmless for any damage, relocation or replacement costs associated with damage, relocation or removal of private property caused by the City performing work in the public way.

Authority for the above named privilege is herein given and granted from and after March 1, 2014 through and including December 1, 2014.

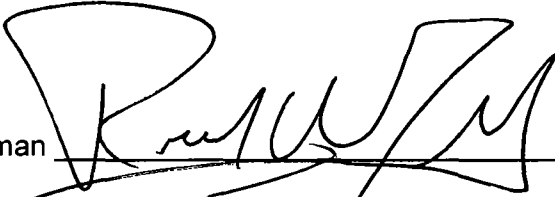
Alderman 
Bob Fioretti 2nd Ward



05/28/2014

Alderman Bob Fioretti
Ward # 02
City of Chicago
City Hall, Room 300
121 North LaSalle Street
Chicago, Illinois 60602

Re: An ordinance to use and maintain a portion of the public right-of-way for **two (2) sidewalk cafe(s)** for **Al's Beef**, adjacent to the premises known as **601 W. Adams St.**

Dear Alderman **Bob Fioretti**:

The applicant referenced above has requested the use of the public right-of-way for a **sidewalk cafe(s)**. An ordinance has been prepared by the Department of Business Affairs and Consumer Protection – Small Business Center - Public Way Use Unit for presentation to the City Council. Because this request was made for properties located in your ward, as approved by you as per the attached, I respectfully request that you introduce the attached ordinance at the next City Council meeting.

If you have any questions regarding this ordinance, please contact Anthony Bertuca at (312) 744-5506.

Department of Business Affairs and Consumer Protection



City of Chicago



O2014-4340

Office of the City Clerk

Document Tracking Sheet

| | |
|---------------------------------|--|
| Meeting Date: | 5/28/2014 |
| Sponsor(s): | Fioretti (2) |
| Type: | Ordinance |
| Title: | Sidewalk cafe(s) for Acadia Restaurant |
| Committee(s) Assignment: | Committee on Transportation and Public Way |

ORDINANCE
ACADIA RESTAURANT
Acct. No. 358920 - 1
Permit No. 1112912

Be It Ordained by the City Council of the City of Chicago:

Permission and authority are hereby given and granted to ACADIA RESTAURANT upon the terms and subject to the conditions of this ordinance, to maintain and use a portion of the public right of way for a sidewalk cafe adjacent to its premises located at 1639 S. Wabash Ave.. Said sidewalk cafe area #1 shall be twenty-seven point three three (27.33) feet in length and six (6) feet in width for a total of one hundred sixty-three point nine eight (163.98) square feet and shall allow six (6) feet of clear space from the face of the curb/building line along S. Wabash Avenue. The compensation for said space and the days and hours of operation for the sidewalk cafe shall be as follows:

Tuesday through Thursday 5:30 p.m. to 10:00 p.m. Friday and Saturday 5:00 p.m. to 11:00 p.m. Sunday 11:00 a.m. to 10:00 p.m.
Compensation: \$600.00
SEATING CAPACITY: 16

Sidewalk Cafe Permit and approved plan must be posted at all times.

This grant of privilege #1112912 for a sidewalk cafe shall be subject to the provisions of Section 10-28-800 through 10-28-885 of the Municipal Code of Chicago and the directions of the Commissioner of Department of Business Affairs and Consumer Protection, the Commissioner of Streets and Sanitation, and the Commissioner of Transportation.

The permit holder agrees to hold the City of Chicago harmless for any damage, relocation or replacement costs associated with damage, relocation or removal of private property caused by the City performing work in the public way.

Authority for the above named privilege is herein given and granted from and after March 1, 2014 through and including December 1, 2014.

Alderman

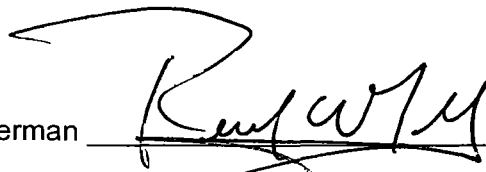

Bob Fioretti 2nd Ward



05/28/2014

Alderman **Bob Fioretti**
Ward # **02**
City of Chicago
City Hall, Room **300**
121 North LaSalle Street
Chicago, Illinois 60602

Re: An ordinance to use and maintain a portion of the public right-of-way for **one (1) sidewalk cafe(s)** for **ACADIA RESTAURANT**, adjacent to the premises known as **1639 S. Wabash Ave.**.

Dear Alderman **Bob Fioretti**:

The applicant referenced above has requested the use of the public right-of-way for a **sidewalk cafe(s)**. An ordinance has been prepared by the Department of Business Affairs and Consumer Protection – Small Business Center - Public Way Use Unit for presentation to the City Council. Because this request was made for properties located in your ward, as approved by you as per the attached, I respectfully request that you introduce the attached ordinance at the next City Council meeting.

If you have any questions regarding this ordinance, please contact Anthony Bertuca at (312) 744-5506.

Department of Business Affairs and Consumer Protection



City of Chicago



O2014-4345

Office of the City Clerk

Document Tracking Sheet

| | |
|---------------------------------|--|
| Meeting Date: | 5/28/2014 |
| Sponsor(s): | Fioretti (2) |
| Type: | Ordinance |
| Title: | Sidewalk cafe(s) for Epples Restaurant |
| Committee(s) Assignment: | Committee on Transportation and Public Way |

ORDINANCE
EPPLES RESTAURANT
Acct. No. 302687 - 1
Permit No. 1112913

Be It Ordained by the City Council of the City of Chicago:

Permission and authority are hereby given and granted to EPPLES RESTAURANT upon the terms and subject to the conditions of this ordinance, to maintain and use a portion of the public right of way for a sidewalk cafe adjacent to its premises located at 554 W. Roosevelt Rd.. Said sidewalk cafe area #1 shall be nineteen (19) feet in length and fourteen (14) feet in width for a total of two hundred sixty-six (266) square feet and shall allow six (6) feet of clear space from the face of the curb/building line along W. Roosevelt Rd. The compensation for said space and the days and hours of operation for the sidewalk cafe shall be as follows:

Saturday through Sunday 8:00 a.m. until 4:00 p.m.
Compensation: \$600.00
SEATING CAPACITY: 16

Sidewalk Cafe Permit and approved plan must be posted at all times.

This grant of privilege #1112913 for a sidewalk cafe shall be subject to the provisions of Section 10-28-800 through 10-28-885 of the Municipal Code of Chicago and the directions of the Commissioner of Department of Business Affairs and Consumer Protection, the Commissioner of Streets and Sanitation, and the Commissioner of Transportation.

The permit holder agrees to hold the City of Chicago harmless for any damage, relocation or replacement costs associated with damage, relocation or removal of private property caused by the City performing work in the public way.

Authority for the above named privilege is herein given and granted from and after March 1, 2014 through and including December 1, 2014.

Alderman 
Bob Fioretti 2nd Ward



05/28/2014

Alderman **Bob Fioretti**
Ward # **02**
City of Chicago
City Hall, Room **300**
121 North LaSalle Street
Chicago, Illinois 60602

Re: An ordinance to use and maintain a portion of the public right-of-way for **one (1) sidewalk cafe(s)** for **EPPLES RESTAURANT**, adjacent to the premises known as **554 W. Roosevelt Rd.**

Dear Alderman **Bob Fioretti**:

The applicant referenced above has requested the use of the public right-of-way for a **sidewalk cafe(s)**. An ordinance has been prepared by the Department of Business Affairs and Consumer Protection – Small Business Center - Public Way Use Unit for presentation to the City Council. Because this request was made for properties located in your ward, as approved by you as per the attached, I respectfully request that you introduce the attached ordinance at the next City Council meeting.

If you have any questions regarding this ordinance, please contact Anthony Bertuca at (312) 744-5506.

Department of Business Affairs and Consumer Protection



City of Chicago



O2014-4351

Office of the City Clerk

Document Tracking Sheet

| | |
|---------------------------------|--|
| Meeting Date: | 5/28/2014 |
| Sponsor(s): | Fioretti (2) |
| Type: | Ordinance |
| Title: | Sidewalk cafe(s) for Waffles |
| Committee(s) Assignment: | Committee on Transportation and Public Way |

ORDINANCE
WAFFLES
Acct. No. 362795 - 1
Permit No. 1113255

Be It Ordained by the City Council of the City of Chicago:

Permission and authority are hereby given and granted to WAFFLES upon the terms and subject to the conditions of this ordinance, to maintain and use a portion of the public right of way for a sidewalk cafe adjacent to its premises located at 1400 S. Michigan Ave.. Said sidewalk cafe area #1 shall be eight point four (8.4) feet in length and eight (8) feet in width, area #2 shall be eight point three (8.3) feet in length and eight (8) feet in width, area #3 shall be ten point three (10.3) feet in length and eight (8) feet in width for a total of two hundred sixteen (216) square feet and shall allow six (6) feet of clear space from the face of the curb/building line along Michigan. The compensation for said space and the days and hours of operation for the sidewalk cafe shall be as follows:

Monday to Sunday 8:00 am - 2:00 pm
Compensation: \$600.00
SEATING CAPACITY: 14

Sidewalk Cafe Permit and approved plan must be posted at all times.

This grant of privilege #1113255 for a sidewalk cafe shall be subject to the provisions of Section 10-28-800 through 10-28-885 of the Municipal Code of Chicago and the directions of the Commissioner of Department of Business Affairs and Consumer Protection, the Commissioner of Streets and Sanitation, and the Commissioner of Transportation.

The permit holder agrees to hold the City of Chicago harmless for any damage, relocation or replacement costs associated with damage, relocation or removal of private property caused by the City performing work in the public way.

Authority for the above named privilege is herein given and granted from and after March 1, 2014 through and including December 1, 2014.

Alderman

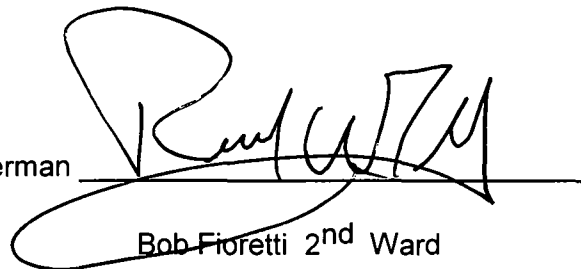

Bob Fioretti 2nd Ward



05/28/2014

Alderman **Bob Fioretti**
Ward # **02**
City of Chicago
City Hall, Room **300**
121 North LaSalle Street
Chicago, Illinois 60602

Re: An ordinance to use and maintain a portion of the public right-of-way for **three (3) sidewalk cafe(s)** for **WAFFLES**, adjacent to the premises known as **1400 S. Michigan Ave.**

Dear Alderman **Bob Fioretti**:

The applicant referenced above has requested the use of the public right-of-way for a **sidewalk cafe(s)**. An ordinance has been prepared by the Department of Business Affairs and Consumer Protection – Small Business Center - Public Way Use Unit for presentation to the City Council. Because this request was made for properties located in your ward, as approved by you as per the attached, I respectfully request that you introduce the attached ordinance at the next City Council meeting.

If you have any questions regarding this ordinance, please contact Anthony Bertuca at (312) 744-5506.

Department of Business Affairs and Consumer Protection



City of Chicago



O2014-4358

Office of the City Clerk

Document Tracking Sheet

| | |
|---------------------------------|--|
| Meeting Date: | 5/28/2014 |
| Sponsor(s): | O'Shea (19) |
| Type: | Ordinance |
| Title: | Sidewalk cafe(s) for Ellie's |
| Committee(s) Assignment: | Committee on Transportation and Public Way |

ORDINANCE

Ellie's

Acct. No. 371175 - 1

Permit No. 1113281

Be It Ordained by the City Council of the City of Chicago:

Permission and authority are hereby given and granted to Ellie's upon the terms and subject to the conditions of this ordinance, to maintain and use a portion of the public right of way for a sidewalk cafe adjacent to its premises located at 10701 S. Hale Ave.. Said sidewalk cafe area #1 shall be thirty-five point five (35.5) feet in length and thirteen point three three (13.33) feet in width for a total of four hundred seventy-three point two two (473.22) square feet and shall allow six (6) feet of clear space from the face of the curb/building line along S. Hale Avenue. The compensation for said space and the days and hours of operation for the sidewalk cafe shall be as follows:

Sunday through Wednesday 8:00 a.m. to 5:00 p.m. Thursday through Saturday 8:00 a.m. to 9:00 p.m.

Compensation: \$600.00

SEATING CAPACITY: 14

Sidewalk Cafe Permit and approved plan must be posted at all times.

This grant of privilege #1113281 for a sidewalk cafe shall be subject to the provisions of Section 10-28-800 through 10-28-885 of the Municipal Code of Chicago and the directions of the Commissioner of Department of Business Affairs and Consumer Protection, the Commissioner of Streets and Sanitation, and the Commissioner of Transportation.

The permit holder agrees to hold the City of Chicago harmless for any damage, relocation or replacement costs associated with damage, relocation or removal of private property caused by the City performing work in the public way.

Authority for the above named privilege is herein given and granted from and after March 1, 2014 through and including December 1, 2014.

Alderman



Matthew J. O'Shea 19th Ward



05/28/2014

Alderman **Matthew J. O'Shea**
Ward # **19**
City of Chicago
City Hall, Room **300**
121 North LaSalle Street
Chicago, Illinois 60602

Re: An ordinance to use and maintain a portion of the public right-of-way for **one (1) sidewalk cafe(s)** for **Ellie's**, adjacent to the premises known as **10701 S. Hale Ave.**

Dear Alderman **Matthew J. O'Shea**:

The applicant referenced above has requested the use of the public right-of-way for a **sidewalk cafe(s)**. An ordinance has been prepared by the Department of Business Affairs and Consumer Protection – Small Business Center - Public Way Use Unit for presentation to the City Council. Because this request was made for properties located in your ward, as approved by you as per the attached, I respectfully request that you introduce the attached ordinance at the next City Council meeting.

If you have any questions regarding this ordinance, please contact Anthony Bertuca at (312) 744-5506.

Department of Business Affairs and Consumer Protection



City of Chicago



O2014-4362

Office of the City Clerk

Document Tracking Sheet

| | |
|---------------------------------|--|
| Meeting Date: | 5/28/2014 |
| Sponsor(s): | Solis (25) |
| Type: | Ordinance |
| Title: | Sidewalk cafe(s) for Jamba Juice |
| Committee(s) Assignment: | Committee on Transportation and Public Way |

ORDINANCE
JAMBA JUICE
Acct. No. 360015 - 4
Permit No. 1113168

Be It Ordained by the City Council of the City of Chicago:

Permission and authority are hereby given and granted to JAMBA JUICE upon the terms and subject to the conditions of this ordinance, to maintain and use a portion of the public right of way for a sidewalk cafe adjacent to its premises located at 1322 S. Halsted St.. Said sidewalk cafe area #1 shall be thirty (30) feet in length and five (5) feet in width, area #2 shall be twenty (20) feet in length and ten (10) feet in width for a total of three hundred fifty (350) square feet and shall allow six (6) feet of clear space from the face of the curb/building line along S. Halsted St, Maxwell St. The compensation for said space and the days and hours of operation for the sidewalk cafe shall be as follows:

Sunday through Saturday 8:00am until 10:00pm
Compensation: \$600.00
SEATING CAPACITY: 24

Sidewalk Cafe Permit and approved plan must be posted at all times.

This grant of privilege #1113168 for a sidewalk cafe shall be subject to the provisions of Section 10-28-800 through 10-28-885 of the Municipal Code of Chicago and the directions of the Commissioner of Department of Business Affairs and Consumer Protection, the Commissioner of Streets and Sanitation, and the Commissioner of Transportation.

The permit holder agrees to hold the City of Chicago harmless for any damage, relocation or replacement costs associated with damage, relocation or removal of private property caused by the City performing work in the public way.

Authority for the above named privilege is herein given and granted from and after March 1, 2014 through and including December 1, 2014.

Alderman _____

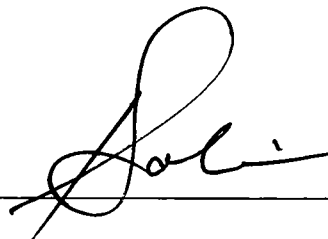

Daniel S. Solis 25th Ward



05/28/2014

Alderman **Daniel S. Solis**
Ward # **25**
City of Chicago
City Hall, Room **203**
121 North LaSalle Street
Chicago, Illinois 60602

Re: An ordinance to use and maintain a portion of the public right-of-way for **two (2) sidewalk cafe(s)** for **JAMBA JUICE**, adjacent to the premises known as **1322 S. Halsted St.**

Dear Alderman **Daniel S. Solis**:

The applicant referenced above has requested the use of the public right-of-way for a **sidewalk cafe(s)**. An ordinance has been prepared by the Department of Business Affairs and Consumer Protection – Small Business Center - Public Way Use Unit for presentation to the City Council. Because this request was made for properties located in your ward, as approved by you as per the attached, I respectfully request that you introduce the attached ordinance at the next City Council meeting.

If you have any questions regarding this ordinance, please contact Anthony Bertuca at (312) 744-5506.

Department of Business Affairs and Consumer Protection



City of Chicago



O2014-4368

Office of the City Clerk
Document Tracking Sheet

| | |
|---------------------------------|--|
| Meeting Date: | 5/28/2014 |
| Sponsor(s): | Maldonado (26) |
| Type: | Ordinance |
| Title: | Sidewalk cafe(s) for Cafe Colao |
| Committee(s) Assignment: | Committee on Transportation and Public Way |

ORDINANCE
CAFE COLAO
Acct. No. 311583 - 1
Permit No. 1113244

Be It Ordained by the City Council of the City of Chicago:

Permission and authority are hereby given and granted to CAFE COLAO upon the terms and subject to the conditions of this ordinance, to maintain and use a portion of the public right of way for a sidewalk cafe adjacent to its premises located at 2638 W. Division St.. Said sidewalk cafe area #1 shall be eleven point eight three (11.83) feet in length and seventeen (17) feet in width for a total of two hundred one point one one (201.11) square feet and shall allow six (6) feet of clear space from the face of the curb/building line along W. Division Street. The compensation for said space and the days and hours of operation for the sidewalk cafe shall be as follows:

Monday through Sunday 8:00 a.m. to 9:00 p.m.
Compensation: \$600.00
SEATING CAPACITY: 24

Sidewalk Cafe Permit and approved plan must be posted at all times.

This grant of privilege #1113244 for a sidewalk cafe shall be subject to the provisions of Section 10-28-800 through 10-28-885 of the Municipal Code of Chicago and the directions of the Commissioner of Department of Business Affairs and Consumer Protection, the Commissioner of Streets and Sanitation, and the Commissioner of Transportation.

The permit holder agrees to hold the City of Chicago harmless for any damage, relocation or replacement costs associated with damage, relocation or removal of private property caused by the City performing work in the public way.

Authority for the above named privilege is herein given and granted from and after March 1, 2014 through and including December 1, 2014.

Alderman 

Roberto Maldonado 26th Ward



05/28/2014

Alderman **Roberto Maldonado**
Ward # **26**
City of Chicago
City Hall, Room **300**
121 North LaSalle Street
Chicago, Illinois 60602

Re: An ordinance to use and maintain a portion of the public right-of-way for **one (1) sidewalk cafe(s)** for **CAFE COLAO**, adjacent to the premises known as **2638 W. Division St.**

Dear Alderman **Roberto Maldonado**:

The applicant referenced above has requested the use of the public right-of-way for a **sidewalk cafe(s)**. An ordinance has been prepared by the Department of Business Affairs and Consumer Protection – Small Business Center - Public Way Use Unit for presentation to the City Council. Because this request was made for properties located in your ward, as approved by you as per the attached, I respectfully request that you introduce the attached ordinance at the next City Council meeting.

If you have any questions regarding this ordinance, please contact Anthony Bertuca at (312) 744-5506.

Department of Business Affairs and Consumer Protection



City of Chicago



O2014-4374

Office of the City Clerk

Document Tracking Sheet

| | |
|---------------------------------|--|
| Meeting Date: | 5/28/2014 |
| Sponsor(s): | Maldonado (26) |
| Type: | Ordinance |
| Title: | Sidewalk cafe(s) for Lockdown |
| Committee(s) Assignment: | Committee on Transportation and Public Way |

ORDINANCE
LOCKDOWN
Acct. No. 342561 - 1
Permit No. 1113295

Be It Ordained by the City Council of the City of Chicago:

Permission and authority are hereby given and granted to LOCKDOWN upon the terms and subject to the conditions of this ordinance, to maintain and use a portion of the public right of way for a sidewalk cafe adjacent to its premises located at 1024 N. Western Ave.. Said sidewalk cafe area #1 shall be fifteen (15) feet in length and six (6) feet in width, area #2 shall be forty-three (43) feet in length and seven (7) feet in width for a total of three hundred ninety-one (391) square feet and shall allow six (6) feet of clear space from the face of the curb/building line along N Western Ave, W. Cortez. The compensation for said space and the days and hours of operation for the sidewalk cafe shall be as follows:

Sunday through Saturday 11:00 a.m. 12:00 a.m.
Compensation: \$600.00
SEATING CAPACITY: 29

Sidewalk Cafe Permit and approved plan must be posted at all times.

This grant of privilege #1113295 for a sidewalk cafe shall be subject to the provisions of Section 10-28-800 through 10-28-885 of the Municipal Code of Chicago and the directions of the Commissioner of Department of Business Affairs and Consumer Protection, the Commissioner of Streets and Sanitation, and the Commissioner of Transportation.

The permit holder agrees to hold the City of Chicago harmless for any damage, relocation or replacement costs associated with damage, relocation or removal of private property caused by the City performing work in the public way.

Authority for the above named privilege is herein given and granted from and after March 1, 2014 through and including December 1, 2014.

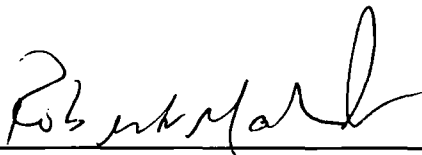
Alderman 

Roberto Maldonado 26th Ward



05/28/2014

Alderman **Roberto Maldonado**
Ward # 26
City of Chicago
City Hall, Room 300
121 North LaSalle Street
Chicago, Illinois 60602

Re: An ordinance to use and maintain a portion of the public right-of-way for **two (2) sidewalk cafe(s)** for **LOCKDOWN**, adjacent to the premises known as **1024 N. Western Ave.**

Dear Alderman **Roberto Maldonado**:

The applicant referenced above has requested the use of the public right-of-way for a **sidewalk cafe(s)**. An ordinance has been prepared by the Department of Business Affairs and Consumer Protection – Small Business Center - Public Way Use Unit for presentation to the City Council. Because this request was made for properties located in your ward, as approved by you as per the attached, I respectfully request that you introduce the attached ordinance at the next City Council meeting.

If you have any questions regarding this ordinance, please contact Anthony Bertuca at (312) 744-5506.

Department of Business Affairs and Consumer Protection



City of Chicago



O2014-4377

Office of the City Clerk
Document Tracking Sheet

| | |
|---------------------------------|---|
| Meeting Date: | 5/28/2014 |
| Sponsor(s): | Maldonado (26) |
| Type: | Ordinance |
| Title: | Sidewalk cafe(s) for Papa's Cache Sabroso, Inc. |
| Committee(s) Assignment: | Committee on Transportation and Public Way |

ORDINANCE
PAPA'S CACHE SABROSO INC
Acct. No. 298114 - 1
Permit No. 1113293

Be It Ordained by the City Council of the City of Chicago:

Permission and authority are hereby given and granted to PAPA'S CACHE SABROSO INC upon the terms and subject to the conditions of this ordinance, to maintain and use a portion of the public right of way for a sidewalk cafe adjacent to its premises located at 2517 W. Division St.. Said sidewalk cafe area #1 shall be seventeen (17) feet in length and eighteen (18) feet in width for a total of three hundred six (306) square feet and shall allow six (6) feet of clear space from the face of the curb/building line along W Division St. The compensation for said space and the days and hours of operation for the sidewalk cafe shall be as follows:

Monday thru Thursday 11:00 thru 11:00 p.m.
Friday and Saturday 11:00 a.m. until 12:00 Midnight
Compensation: \$600.00
SEATING CAPACITY: 20

Sidewalk Cafe Permit and approved plan must be posted at all times.

This grant of privilege #1113293 for a sidewalk cafe shall be subject to the provisions of Section 10-28-800 through 10-28-885 of the Municipal Code of Chicago and the directions of the Commissioner of Department of Business Affairs and Consumer Protection, the Commissioner of Streets and Sanitation, and the Commissioner of Transportation.

The permit holder agrees to hold the City of Chicago harmless for any damage, relocation or replacement costs associated with damage, relocation or removal of private property caused by the City performing work in the public way.

Authority for the above named privilege is herein given and granted from and after March 1, 2014 through and including December 1, 2014.

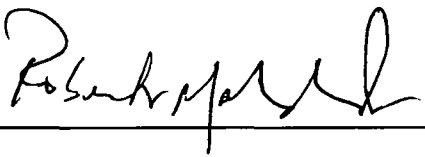
Alderman 
Roberto Maldonado 26th Ward



05/28/2014

Alderman **Roberto Maldonado**
Ward # 26
City of Chicago
City Hall, Room 300
121 North LaSalle Street
Chicago, Illinois 60602

Re: An ordinance to use and maintain a portion of the public right-of-way for **one (1) sidewalk cafe(s)** for **PAPA'S CACHE SABROSO INC**, adjacent to the premises known as **2517 W. Division St.**.

Dear Alderman **Roberto Maldonado**:

The applicant referenced above has requested the use of the public right-of-way for a **sidewalk cafe(s)**. An ordinance has been prepared by the Department of Business Affairs and Consumer Protection – Small Business Center - Public Way Use Unit for presentation to the City Council. Because this request was made for properties located in your ward, as approved by you as per the attached, I respectfully request that you introduce the attached ordinance at the next City Council meeting.

If you have any questions regarding this ordinance, please contact Anthony Bertuca at (312) 744-5506.

Department of Business Affairs and Consumer Protection



City of Chicago



O2014-4388

Office of the City Clerk

Document Tracking Sheet

| | |
|---------------------------------|--|
| Meeting Date: | 5/28/2014 |
| Sponsor(s): | Maldonado (26) |
| Type: | Ordinance |
| Title: | Sidewalk cafe(s) for Upton's Naturals Co. |
| Committee(s) Assignment: | Committee on Transportation and Public Way |

ORDINANCE
UPTON' S NATURALS CO.
Acct. No. 367187 - 2
Permit No. 1113055

Be It Ordained by the City Council of the City of Chicago:

Permission and authority are hereby given and granted to UPTON' S NATURALS CO. upon the terms and subject to the conditions of this ordinance, to maintain and use a portion of the public right of way for a sidewalk cafe adjacent to its premises located at 2054 W. Grand Ave.. Said sidewalk cafe area #1 shall be twenty-seven (27) feet in length and six (6) feet in width for a total of one hundred sixty-two (162) square feet and shall allow six (6) feet of clear space from the face of the curb/building line along N. Hoyne. The compensation for said space and the days and hours of operation for the sidewalk cafe shall be as follows:

Monday through Sunday 9:00 a.m. to 9:00 p.m.
Compensation: \$600.00
SEATING CAPACITY: 12

Sidewalk Cafe Permit and approved plan must be posted at all times.

This grant of privilege #1113055 for a sidewalk cafe shall be subject to the provisions of Section 10-28-800 through 10-28-885 of the Municipal Code of Chicago and the directions of the Commissioner of Department of Business Affairs and Consumer Protection, the Commissioner of Streets and Sanitation, and the Commissioner of Transportation.

The permit holder agrees to hold the City of Chicago harmless for any damage, relocation or replacement costs associated with damage, relocation or removal of private property caused by the City performing work in the public way.

Authority for the above named privilege is herein given and granted from and after March 1, 2014 through and including December 1, 2014.

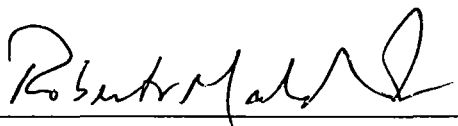
Alderman 

Roberto Maldonado 26th Ward



05/28/2014

Alderman **Roberto Maldonado**
Ward # **26**
City of Chicago
City Hall, Room **300**
121 North LaSalle Street
Chicago, Illinois 60602

Re: An ordinance to use and maintain a portion of the public right-of-way for **one (1) sidewalk cafe(s)** for **UPTON' S NATURALS CO.**, adjacent to the premises known as **2054 W. Grand Ave.**.

Dear Alderman **Roberto Maldonado**:

The applicant referenced above has requested the use of the public right-of-way for a **sidewalk cafe(s)**. An ordinance has been prepared by the Department of Business Affairs and Consumer Protection – Small Business Center - Public Way Use Unit for presentation to the City Council. Because this request was made for properties located in your ward, as approved by you as per the attached, I respectfully request that you introduce the attached ordinance at the next City Council meeting.

If you have any questions regarding this ordinance, please contact Anthony Bertuca at (312) 744-5506.

Department of Business Affairs and Consumer Protection



City of Chicago



O2014-4393

Office of the City Clerk

Document Tracking Sheet

| | |
|---------------------------------|--|
| Meeting Date: | 5/28/2014 |
| Sponsor(s): | Maldonado (26) |
| Type: | Ordinance |
| Title: | Sidewalk cafe(s) for Vainilla Bean Bake Shop, Inc. |
| Committee(s) Assignment: | Committee on Transportation and Public Way |

ORDINANCE
VAINILLA BEAN BAKE SHOP INC.
Acct. No. 388502 - 1
Permit No. 1113167

Be It Ordained by the City Council of the City of Chicago:

Permission and authority are hereby given and granted to VAINILLA BEAN BAKE SHOP INC. upon the terms and subject to the conditions of this ordinance, to maintain and use a portion of the public right of way for a sidewalk cafe adjacent to its premises located at 2627 W. Division St.. Said sidewalk cafe area #1 shall be fifteen (15) feet in length and twelve (12) feet in width for a total of one hundred eighty (180) square feet and shall allow six (6) feet of clear space from the face of the curb/building line along W. Division Street. The compensation for said space and the days and hours of operation for the sidewalk cafe shall be as follows:

Tuesday through Saturday 8:00 a.m. to 5:00 p.m.
Compensation: \$600.00
SEATING CAPACITY: 16

Sidewalk Cafe Permit and approved plan must be posted at all times.

This grant of privilege #1113167 for a sidewalk cafe shall be subject to the provisions of Section 10-28-800 through 10-28-885 of the Municipal Code of Chicago and the directions of the Commissioner of Department of Business Affairs and Consumer Protection, the Commissioner of Streets and Sanitation, and the Commissioner of Transportation.

The permit holder agrees to hold the City of Chicago harmless for any damage, relocation or replacement costs associated with damage, relocation or removal of private property caused by the City performing work in the public way.

Authority for the above named privilege is herein given and granted from and after March 1, 2014 through and including December 1, 2014.

Alderman 
Roberto Maldonado 26th Ward



05/28/2014

Alderman Roberto Maldonado
Ward # 26
City of Chicago
City Hall, Room 300
121 North LaSalle Street
Chicago, Illinois 60602

Re: An ordinance to use and maintain a portion of the public right-of-way for **one (1) sidewalk cafe(s)** for **VAINILLA BEAN BAKE SHOP INC.**, adjacent to the premises known as **2627 W. Division St.**

Dear Alderman **Roberto Maldonado**:

The applicant referenced above has requested the use of the public right-of-way for a **sidewalk cafe(s)**. An ordinance has been prepared by the Department of Business Affairs and Consumer Protection – Small Business Center - Public Way Use Unit for presentation to the City Council. Because this request was made for properties located in your ward, as approved by you as per the attached, I respectfully request that you introduce the attached ordinance at the next City Council meeting.

If you have any questions regarding this ordinance, please contact Anthony Bertuca at (312) 744-5506.

Department of Business Affairs and Consumer Protection



City of Chicago



O2014-4397

Office of the City Clerk

Document Tracking Sheet

| | |
|---------------------------------|--|
| Meeting Date: | 5/28/2014 |
| Sponsor(s): | Burnett (27) |
| Type: | Ordinance |
| Title: | Sidewalk cafe(s) for Arista Foods |
| Committee(s) Assignment: | Committee on Transportation and Public Way |

ORDINANCE
ARISTA FOODS
Acct. No. 271891 - 1
Permit No. 1113254

Be It Ordained by the City Council of the City of Chicago:

Permission and authority are hereby given and granted to ARISTA FOODS upon the terms and subject to the conditions of this ordinance, to maintain and use a portion of the public right of way for a sidewalk cafe adjacent to its premises located at 112 N. May St.. Said sidewalk cafe area #1 shall be thirty point eight eight (30.88) feet in length and four (4) feet in width for a total of one hundred twenty-three point five two (123.52) square feet and shall allow six (6) feet of clear space from the face of the curb/building line along MAY STREET. The compensation for said space and the days and hours of operation for the sidewalk cafe shall be as follows:

Monday thru Friday 8:00 a.m. until 8:00 p.m. Saturday 11:00 a.m. until 5:00 p.m.
Compensation: \$600.00
SEATING CAPACITY: 14

Sidewalk Cafe Permit and approved plan must be posted at all times.

This grant of privilege #1113254 for a sidewalk cafe shall be subject to the provisions of Section 10-28-800 through 10-28-885 of the Municipal Code of Chicago and the directions of the Commissioner of Department of Business Affairs and Consumer Protection, the Commissioner of Streets and Sanitation, and the Commissioner of Transportation.

The permit holder agrees to hold the City of Chicago harmless for any damage, relocation or replacement costs associated with damage, relocation or removal of private property caused by the City performing work in the public way.

Authority for the above named privilege is herein given and granted from and after March 1, 2014 through and including December 1, 2014.

Alderman

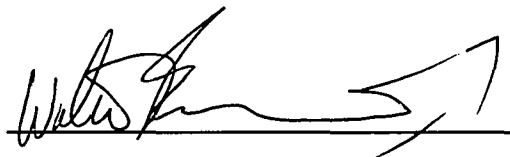

Walter Burnett Jr. 27th Ward



City of Chicago



O2014-4400

Office of the City Clerk

Document Tracking Sheet

| | |
|---------------------------------|--|
| Meeting Date: | 5/28/2014 |
| Sponsor(s): | Burnett (27) |
| Type: | Ordinance |
| Title: | Sidewalk cafe(s) for Glazed and Infused |
| Committee(s) Assignment: | Committee on Transportation and Public Way |

ORDINANCE
Glazed and Infused
Acct. No. 372092 - 1
Permit No. 1113062

Be It Ordained by the City Council of the City of Chicago:

Permission and authority are hereby given and granted to Glazed and Infused upon the terms and subject to the conditions of this ordinance, to maintain and use a portion of the public right of way for a sidewalk cafe adjacent to its premises located at 813 W. Fulton Market . Said sidewalk cafe area #1 shall be eleven point five (11.5) feet in length and four point three three (4.33) feet in width for a total of forty-nine point eight (49.8) square feet and shall allow six (6) feet of clear space from the face of the curb/building line along W. Fulton Market. The compensation for said space and the days and hours of operation for the sidewalk cafe shall be as follows:

Saturday and Sunday 8:00 a.m. to 3:00 p.m. Monday through Thursday 8:00 a.m. to 2:00 p.m. Friday 8:00 a.m. to 5:00 p.m.
Compensation: \$600.00
SEATING CAPACITY: 6

Sidewalk Cafe Permit and approved plan must be posted at all times.

This grant of privilege #1113062 for a sidewalk cafe shall be subject to the provisions of Section 10-28-800 through 10-28-885 of the Municipal Code of Chicago and the directions of the Commissioner of Department of Business Affairs and Consumer Protection, the Commissioner of Streets and Sanitation, and the Commissioner of Transportation.

The permit holder agrees to hold the City of Chicago harmless for any damage, relocation or replacement costs associated with damage, relocation or removal of private property caused by the City performing work in the public way.

Authority for the above named privilege is herein given and granted from and after March 1, 2014 through and including December 1, 2014.

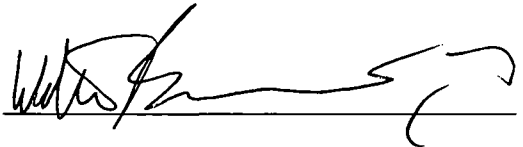
Alderman 
Walter Burnett Jr. 27th Ward



City of Chicago



O2014-4405

Office of the City Clerk

Document Tracking Sheet

| | |
|---------------------------------|--|
| Meeting Date: | 5/28/2014 |
| Sponsor(s): | Burnett (27) |
| Type: | Ordinance |
| Title: | Sidewalk cafe(s) for Viaggio |
| Committee(s) Assignment: | Committee on Transportation and Public Way |

ORDINANCE
VIAGGIO
Acct. No. 275310 - 1
Permit No. 1113278

Be It Ordained by the City Council of the City of Chicago:

Permission and authority are hereby given and granted to VIAGGIO upon the terms and subject to the conditions of this ordinance, to maintain and use a portion of the public right of way for a sidewalk cafe adjacent to its premises located at 1330 W. Madison St.. Said sidewalk cafe area #1 shall be twenty-four (24) feet in length and four (4) feet in width, area #2 shall be ten (10) feet in length and four (4) feet in width, area #3 shall be ten (10) feet in length and four (4) feet in width for a total of one hundred seventy-six (176) square feet and shall allow six (6) feet of clear space from the face of the curb/building line along W. Madison Street. The compensation for said space and the days and hours of operation for the sidewalk cafe shall be as follows:

Monday through Sunday 8:00 a.m. to 12:00 midnight
Compensation: \$600.00
SEATING CAPACITY: 26

Sidewalk Cafe Permit and approved plan must be posted at all times.

This grant of privilege #1113278 for a sidewalk cafe shall be subject to the provisions of Section 10-28-800 through 10-28-885 of the Municipal Code of Chicago and the directions of the Commissioner of Department of Business Affairs and Consumer Protection, the Commissioner of Streets and Sanitation, and the Commissioner of Transportation.

The permit holder agrees to hold the City of Chicago harmless for any damage, relocation or replacement costs associated with damage, relocation or removal of private property caused by the City performing work in the public way.

Authority for the above named privilege is herein given and granted from and after March 1, 2014 through and including December 1, 2014.

Alderman 
Walter Burnett Jr. 27th Ward



City of Chicago



O2014-4411

Office of the City Clerk

Document Tracking Sheet

| | |
|---------------------------------|--|
| Meeting Date: | 5/28/2014 |
| Sponsor(s): | Burnett (27) |
| Type: | Ordinance |
| Title: | Sidewalk cafe(s) for Vinnies Sub Shop |
| Committee(s) Assignment: | Committee on Transportation and Public Way |

ORDINANCE
VINNIES SUB SHOP
Acct. No. 287154 - 1
Permit No. 1113054

Be It Ordained by the City Council of the City of Chicago:

Permission and authority are hereby given and granted to VINNIES SUB SHOP upon the terms and subject to the conditions of this ordinance, to maintain and use a portion of the public right of way for a sidewalk cafe adjacent to its premises located at 1204 W. Grand Ave.. Said sidewalk cafe area #1 shall be twenty-five (25) feet in length and four (4) feet in width for a total of one hundred (100) square feet and shall allow six (6) feet of clear space from the face of the curb/building line along W. Grand. The compensation for said space and the days and hours of operation for the sidewalk cafe shall be as follows:

Monday through Friday 8:00 am to 7:00 pm. Saturday 8:00 am to 5:00 pm.
Compensation: \$600.00
SEATING CAPACITY: 12

Sidewalk Cafe Permit and approved plan must be posted at all times.

This grant of privilege #1113054 for a sidewalk cafe shall be subject to the provisions of Section 10-28-800 through 10-28-885 of the Municipal Code of Chicago and the directions of the Commissioner of Department of Business Affairs and Consumer Protection, the Commissioner of Streets and Sanitation, and the Commissioner of Transportation.

The permit holder agrees to hold the City of Chicago harmless for any damage, relocation or replacement costs associated with damage, relocation or removal of private property caused by the City performing work in the public way.

Authority for the above named privilege is herein given and granted from and after March 1, 2014 through and including December 1, 2014.

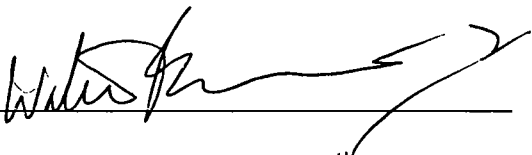
Alderman 
Walter Burnett Jr. 27th Ward



City of Chicago



O2014-4419

Office of the City Clerk

Document Tracking Sheet

| | |
|---------------------------------|--|
| Meeting Date: | 5/28/2014 |
| Sponsor(s): | Reboyras (30) |
| Type: | Ordinance |
| Title: | Sidewalk cafe(s) for Mambo Cafe |
| Committee(s) Assignment: | Committee on Transportation and Public Way |

ORDINANCE
MAMBO CAFE
Acct. No. 32331 - 1
Permit No. 1113140

Be It Ordained by the City Council of the City of Chicago:

Permission and authority are hereby given and granted to MAMBO CAFE upon the terms and subject to the conditions of this ordinance, to maintain and use a portion of the public right of way for a sidewalk cafe adjacent to its premises located at 3336-3342 N. Milwaukee Ave.. Said sidewalk cafe area #1 shall be forty (40) feet in length and seven (7) feet in width for a total of two hundred eighty (280) square feet and shall allow six (6) feet of clear space from the face of the curb/building line along Keystone St.. The compensation for said space and the days and hours of operation for the sidewalk cafe shall be as follows:

Monday through Sunday 11:00am until 12:00 Midnight
Compensation: \$600.00
SEATING CAPACITY: 20

Sidewalk Cafe Permit and approved plan must be posted at all times.

This grant of privilege #1113140 for a sidewalk cafe shall be subject to the provisions of Section 10-28-800 through 10-28-885 of the Municipal Code of Chicago and the directions of the Commissioner of Department of Business Affairs and Consumer Protection, the Commissioner of Streets and Sanitation, and the Commissioner of Transportation.

The permit holder agrees to hold the City of Chicago harmless for any damage, relocation or replacement costs associated with damage, relocation or removal of private property caused by the City performing work in the public way.

Authority for the above named privilege is herein given and granted from and after March 1, 2014 through and including December 1, 2014.

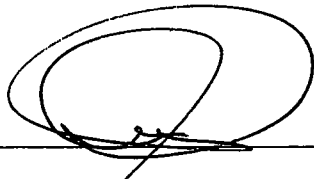
Alderman _____

Ariel Reboyras 30th Ward



05/28/2014

Alderman **Ariel Reboyras**
Ward # **30**
City of Chicago
City Hall, Room **203**
121 North LaSalle Street
Chicago, Illinois 60602

Re: An ordinance to use and maintain a portion of the public right-of-way for **one (1) sidewalk cafe(s)** for **MAMBO CAFE**, adjacent to the premises known as **3336-3342 N. Milwaukee Ave.**.

Dear Alderman **Ariel Reboyras**:

The applicant referenced above has requested the use of the public right-of-way for a **sidewalk cafe(s)**. An ordinance has been prepared by the Department of Business Affairs and Consumer Protection – Small Business Center - Public Way Use Unit for presentation to the City Council. Because this request was made for properties located in your ward, as approved by you as per the attached, I respectfully request that you introduce the attached ordinance at the next City Council meeting.

If you have any questions regarding this ordinance, please contact Anthony Bertuca at (312) 744-5506.

Department of Business Affairs and Consumer Protection



City of Chicago



O2014-4422

Office of the City Clerk

Document Tracking Sheet

| | |
|---------------------------------|--|
| Meeting Date: | 5/28/2014 |
| Sponsor(s): | Waguespack (32) |
| Type: | Ordinance |
| Title: | Sidewalk cafe(s) for Bird's Nest |
| Committee(s) Assignment: | Committee on Transportation and Public Way |

ORDINANCE
BIRD'S NEST
Acct. No. 16437 - 1
Permit No. 1113270

Be It Ordained by the City Council of the City of Chicago:

Permission and authority are hereby given and granted to BIRD'S NEST upon the terms and subject to the conditions of this ordinance, to maintain and use a portion of the public right of way for a sidewalk cafe adjacent to its premises located at 2500 N. Southport Ave.. Said sidewalk cafe area #1 shall be seventy (70) feet in length and eight point eight three (8.83) feet in width for a total of six hundred eighteen point one (618.1) square feet and shall allow six (6) feet of clear space from the face of the curb/building line along W. Altgeld Street. The compensation for said space and the days and hours of operation for the sidewalk cafe shall be as follows:

Sunday 10:00 a.m. to 10:00 p.m. Monday through Thursday 11:00 a.m. to 10:00 p.m.
Friday 11:00 a.m. to 11:00 p.m. Saturday 10:00 a.m. to 11:00 p.m.
Compensation: \$679.91
SEATING CAPACITY: 28

Sidewalk Cafe Permit and approved plan must be posted at all times.

This grant of privilege #1113270 for a sidewalk cafe shall be subject to the provisions of Section 10-28-800 through 10-28-885 of the Municipal Code of Chicago and the directions of the Commissioner of Department of Business Affairs and Consumer Protection, the Commissioner of Streets and Sanitation, and the Commissioner of Transportation.

The permit holder agrees to hold the City of Chicago harmless for any damage, relocation or replacement costs associated with damage, relocation or removal of private property caused by the City performing work in the public way.

Authority for the above named privilege is herein given and granted from and after March 1, 2014 through and including December 1, 2014.

Alderman

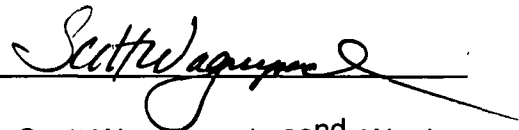

Scott Waguespack 32nd Ward



Department of Business Affairs and Consumer Protection
Small Business Center- Public Way Use Unit
City Hall- 121 N LaSalle Street Room 800 • Chicago, IL 60602
(312)-74-GOBIZ (312-744-6249) • (312) 744-1944 (TTY)
<http://www.cityofchicago.org/bacp>

05/28/2014

Alderman **Scott Waguespack**
Ward # **32**
City of Chicago
City Hall, Room **300**
121 North LaSalle Street
Chicago, Illinois 60602

Re: An ordinance to use and maintain a portion of the public right-of-way for **one (1) sidewalk cafe(s)** for **BIRD'S NEST**, adjacent to the premises known as **2500 N. Southport Ave.**

Dear Alderman **Scott Waguespack**:

The applicant referenced above has requested the use of the public right-of-way for a **sidewalk cafe(s)**. An ordinance has been prepared by the Department of Business Affairs and Consumer Protection – Small Business Center - Public Way Use Unit for presentation to the City Council. Because this request was made for properties located in your ward, as approved by you as per the attached, I respectfully request that you introduce the attached ordinance at the next City Council meeting.

If you have any questions regarding this ordinance, please contact Anthony Bertuca at (312) 744-5506.

Department of Business Affairs and Consumer Protection

A handwritten signature in black ink, appearing to be a stylized name.



City of Chicago



O2014-4428

Office of the City Clerk

Document Tracking Sheet

| | |
|---------------------------------|--|
| Meeting Date: | 5/28/2014 |
| Sponsor(s): | Waguespack (32) |
| Type: | Ordinance |
| Title: | Sidewalk cafe(s) for Butcher & The Burger |
| Committee(s) Assignment: | Committee on Transportation and Public Way |

ORDINANCE
BUTCHER & THE BURGER
Acct. No. 361256 - 1
Permit No. 1113143

Be It Ordained by the City Council of the City of Chicago:

Permission and authority are hereby given and granted to BUTCHER & THE BURGER upon the terms and subject to the conditions of this ordinance, to maintain and use a portion of the public right of way for a sidewalk cafe adjacent to its premises located at 1021 W. Armitage Ave.. Said sidewalk cafe area #1 shall be forty-two point five (42.5) feet in length and seven (7) feet in width for a total of two hundred ninety-seven point five (297.5) square feet and shall allow six (6) feet of clear space from the face of the curb/building line along N. Kenmore Avenue. The compensation for said space and the days and hours of operation for the sidewalk cafe shall be as follows:

Monday and Tuesday 11:00 a.m. to 9:00 p.m. Wednesday through Friday 11:00 a.m. to 10:00 p.m. Saturday 10:00 a.m. to 10:00 p.m. Sunday 10:00 a.m. to 9:00 p.m.
Compensation: \$600.00
SEATING CAPACITY: 12

Sidewalk Cafe Permit and approved plan must be posted at all times.

This grant of privilege #1113143 for a sidewalk cafe shall be subject to the provisions of Section 10-28-800 through 10-28-885 of the Municipal Code of Chicago and the directions of the Commissioner of Department of Business Affairs and Consumer Protection, the Commissioner of Streets and Sanitation, and the Commissioner of Transportation.

The permit holder agrees to hold the City of Chicago harmless for any damage, relocation or replacement costs associated with damage, relocation or removal of private property caused by the City performing work in the public way.

Authority for the above named privilege is herein given and granted from and after March 1, 2014 through and including December 1, 2014.

Alderman

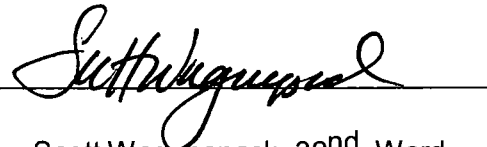

Scott Waguespack 32nd Ward



05/28/2014

Alderman **Scott Waguespack**
Ward # **32**
City of Chicago
City Hall, Room **300**
121 North LaSalle Street
Chicago, Illinois 60602

Re: An ordinance to use and maintain a portion of the public right-of-way for **one (1) sidewalk cafe(s)** for **BUTCHER & THE BURGER**, adjacent to the premises known as **1021 W. Armitage Ave.**.

Dear Alderman **Scott Waguespack**:

The applicant referenced above has requested the use of the public right-of-way for a **sidewalk cafe(s)**. An ordinance has been prepared by the Department of Business Affairs and Consumer Protection – Small Business Center - Public Way Use Unit for presentation to the City Council. Because this request was made for properties located in your ward, as approved by you as per the attached, I respectfully request that you introduce the attached ordinance at the next City Council meeting.

If you have any questions regarding this ordinance, please contact Anthony Bertuca at (312) 744-5506.

Department of Business Affairs and Consumer Protection



City of Chicago



O2014-4432

Office of the City Clerk

Document Tracking Sheet

| | |
|---------------------------------|--|
| Meeting Date: | 5/28/2014 |
| Sponsor(s): | Waguespack (32) |
| Type: | Ordinance |
| Title: | Sidewalk cafe(s) for Fairways |
| Committee(s) Assignment: | Committee on Transportation and Public Way |

ORDINANCE
FAIRWAYS
Acct. No. 376569 - 1
Permit No. 1113231

Be It Ordained by the City Council of the City of Chicago:

Permission and authority are hereby given and granted to FAIRWAYS upon the terms and subject to the conditions of this ordinance, to maintain and use a portion of the public right of way for a sidewalk cafe adjacent to its premises located at 1139-1141 W. Armitage Ave.. Said sidewalk cafe area #1 shall be eighteen point four two (18.42) feet in length and three point eight three (3.83) feet in width for a total of seventy point five five (70.55) square feet and shall allow six (6) feet of clear space from the face of the curb/building line along W. Armitage Avenue. The compensation for said space and the days and hours of operation for the sidewalk cafe shall be as follows:

Sunday through Thursday 8:00 a.m. to 10:00 p.m. Friday and Saturday 8:00 a.m. to 11:00 p.m.
Compensation: \$600.00
SEATING CAPACITY: 12

Sidewalk Cafe Permit and approved plan must be posted at all times.

This grant of privilege #1113231 for a sidewalk cafe shall be subject to the provisions of Section 10-28-800 through 10-28-885 of the Municipal Code of Chicago and the directions of the Commissioner of Department of Business Affairs and Consumer Protection, the Commissioner of Streets and Sanitation, and the Commissioner of Transportation.

The permit holder agrees to hold the City of Chicago harmless for any damage, relocation or replacement costs associated with damage, relocation or removal of private property caused by the City performing work in the public way.

Authority for the above named privilege is herein given and granted from and after March 1, 2014 through and including December 1, 2014.

Alderman



Scott Waguespack 32nd Ward



05/28/2014

Alderman Scott Waguespack
Ward # **32**
City of Chicago
City Hall, Room **300**
121 North LaSalle Street
Chicago, Illinois 60602

Re: An ordinance to use and maintain a portion of the public right-of-way for **one (1) sidewalk cafe(s)** for **FAIRWAYS**, adjacent to the premises known as **1139-1141 W. Armitage Ave.**.

Dear Alderman **Scott Waguespack**:

The applicant referenced above has requested the use of the public right-of-way for a **sidewalk cafe(s)**. An ordinance has been prepared by the Department of Business Affairs and Consumer Protection – Small Business Center - Public Way Use Unit for presentation to the City Council. Because this request was made for properties located in your ward, as approved by you as per the attached, I respectfully request that you introduce the attached ordinance at the next City Council meeting.

If you have any questions regarding this ordinance, please contact Anthony Bertuca at (312) 744-5506.

Department of Business Affairs and Consumer Protection



City of Chicago



O2014-4443

Office of the City Clerk

Document Tracking Sheet

| | |
|---------------------------------|--|
| Meeting Date: | 5/28/2014 |
| Sponsor(s): | Waguespack (32) |
| Type: | Ordinance |
| Title: | Sidewalk cafe(s) for Las Tablas On Lincoln |
| Committee(s) Assignment: | Committee on Transportation and Public Way |

ORDINANCE
LAS TABLAS ON LINCOLN
Acct. No. 304937 - 1
Permit No. 1113056

Be It Ordained by the City Council of the City of Chicago:

Permission and authority are hereby given and granted to LAS TABLAS ON LINCOLN upon the terms and subject to the conditions of this ordinance, to maintain and use a portion of the public right of way for a sidewalk cafe adjacent to its premises located at 2942-44 N. Lincoln Ave.. Said sidewalk cafe area #1 shall be forty-nine point five (49.5) feet in length and eight (8) feet in width for a total of three hundred ninety-six (396) square feet and shall allow six (6) feet of clear space from the face of the curb/building line along N. Lincoln Avenue. The compensation for said space and the days and hours of operation for the sidewalk cafe shall be as follows:

Monday through Thursday 10:00 a.m. to 10:00 p.m. Friday and Saturday 10:00 a.m. to 11:00 p.m. Sunday 10:00 a.m. to 8:00 p.m.
Compensation: \$600.00
SEATING CAPACITY: 14

Sidewalk Cafe Permit and approved plan must be posted at all times.

This grant of privilege #1113056 for a sidewalk cafe shall be subject to the provisions of Section 10-28-800 through 10-28-885 of the Municipal Code of Chicago and the directions of the Commissioner of Department of Business Affairs and Consumer Protection, the Commissioner of Streets and Sanitation, and the Commissioner of Transportation.

The permit holder agrees to hold the City of Chicago harmless for any damage, relocation or replacement costs associated with damage, relocation or removal of private property caused by the City performing work in the public way.

Authority for the above named privilege is herein given and granted from and after March 1, 2014 through and including December 1, 2014.

Alderman 
Scott Waguespack 32nd Ward

Handwritten scribbles or marks at the bottom of the page.



05/28/2014

Alderman **Scott Waguespack**
Ward # **32**
City of Chicago
City Hall, Room **300**
121 North LaSalle Street
Chicago, Illinois 60602

Re: An ordinance to use and maintain a portion of the public right-of-way for **one (1) sidewalk cafe(s)** for **LAS TABLAS ON LINCOLN**, adjacent to the premises known as **2942-44 N. Lincoln Ave.**.

Dear Alderman **Scott Waguespack**:

The applicant referenced above has requested the use of the public right-of-way for a **sidewalk cafe(s)**. An ordinance has been prepared by the Department of Business Affairs and Consumer Protection – Small Business Center - Public Way Use Unit for presentation to the City Council. Because this request was made for properties located in your ward, as approved by you as per the attached, I respectfully request that you introduce the attached ordinance at the next City Council meeting.

If you have any questions regarding this ordinance, please contact Anthony Bertuca at (312) 744-5506.

Department of Business Affairs and Consumer Protection



City of Chicago



O2014-4446

Office of the City Clerk

Document Tracking Sheet

| | |
|---------------------------------|--|
| Meeting Date: | 5/28/2014 |
| Sponsor(s): | Waguespack (32) |
| Type: | Ordinance |
| Title: | Sidewalk cafe(s) for Sofra Turkish Kitchen |
| Committee(s) Assignment: | Committee on Transportation and Public Way |

ORDINANCE
SOFRA TURKISH KITCHEN
Acct. No. 359537 - 1
Permit No. 1113166

Be It Ordained by the City Council of the City of Chicago:

Permission and authority are hereby given and granted to SOFRA TURKISH KITCHEN upon the terms and subject to the conditions of this ordinance, to maintain and use a portion of the public right of way for a sidewalk cafe adjacent to its premises located at 3134 N. Lincoln Ave.. Said sidewalk cafe area #1 shall be nineteen (19) feet in length and six (6) feet in width for a total of one hundred fourteen (114) square feet and shall allow six (6) feet of clear space from the face of the curb/building line along N Lincoln Ave. The compensation for said space and the days and hours of operation for the sidewalk cafe shall be as follows:

Sunday through Thursday 11:00 a.m. until 10:30 p.m. Friday and Saturday 11:00 a.m. until 11:30 p.m.
Compensation: \$600.00
SEATING CAPACITY: 6

Sidewalk Cafe Permit and approved plan must be posted at all times.

This grant of privilege #1113166 for a sidewalk cafe shall be subject to the provisions of Section 10-28-800 through 10-28-885 of the Municipal Code of Chicago and the directions of the Commissioner of Department of Business Affairs and Consumer Protection, the Commissioner of Streets and Sanitation, and the Commissioner of Transportation.

The permit holder agrees to hold the City of Chicago harmless for any damage, relocation or replacement costs associated with damage, relocation or removal of private property caused by the City performing work in the public way.

Authority for the above named privilege is herein given and granted from and after March 1, 2014 through and including December 1, 2014.

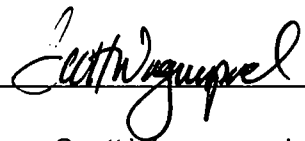
Alderman 
Scott Waguespack 32nd Ward



05/28/2014

Alderman **Scott Waguespack**
Ward # **32**
City of Chicago
City Hall, Room **300**
121 North LaSalle Street
Chicago, Illinois 60602

Re: An ordinance to use and maintain a portion of the public right-of-way for **one (1) sidewalk cafe(s)** for **SOFRA TURKISH KITCHEN**, adjacent to the premises known as **3134 N. Lincoln Ave.**.

Dear Alderman **Scott Waguespack**:

The applicant referenced above has requested the use of the public right-of-way for a **sidewalk cafe(s)**. An ordinance has been prepared by the Department of Business Affairs and Consumer Protection – Small Business Center - Public Way Use Unit for presentation to the City Council. Because this request was made for properties located in your ward, as approved by you as per the attached, I respectfully request that you introduce the attached ordinance at the next City Council meeting.

If you have any questions regarding this ordinance, please contact Anthony Bertuca at (312) 744-5506.

Department of Business Affairs and Consumer Protection



City of Chicago



O2014-4450

Office of the City Clerk

Document Tracking Sheet

| | |
|---------------------------------|--|
| Meeting Date: | 5/28/2014 |
| Sponsor(s): | Mell (33) |
| Type: | Ordinance |
| Title: | Sidewalk cafe(s) for Antojitos Majicos |
| Committee(s) Assignment: | Committee on Transportation and Public Way |

ORDINANCE
ANTOJITOS MAJICOS
Acct. No. 377163 - 2
Permit No. 1113131

Be It Ordained by the City Council of the City of Chicago:

Permission and authority are hereby given and granted to ANTOJITOS MAJICOS upon the terms and subject to the conditions of this ordinance, to maintain and use a portion of the public right of way for a sidewalk cafe adjacent to its premises located at 3540 W. Lawrence Ave.. Said sidewalk cafe area #1 shall be seventeen (17) feet in length and four (4) feet in width for a total of sixty-eight (68) square feet and shall allow six (6) feet of clear space from the face of the curb/building line along W. Lawrence Avenue. The compensation for said space and the days and hours of operation for the sidewalk cafe shall be as follows:

Monday through Sunday 8:00 a.m. to 9:00 p.m.
Compensation: \$600.00
SEATING CAPACITY: 9

Sidewalk Cafe Permit and approved plan must be posted at all times.

This grant of privilege #1113131 for a sidewalk cafe shall be subject to the provisions of Section 10-28-800 through 10-28-885 of the Municipal Code of Chicago and the directions of the Commissioner of Department of Business Affairs and Consumer Protection, the Commissioner of Streets and Sanitation, and the Commissioner of Transportation.

The permit holder agrees to hold the City of Chicago harmless for any damage, relocation or replacement costs associated with damage, relocation or removal of private property caused by the City performing work in the public way.

Authority for the above named privilege is herein given and granted from and after March 1, 2014 through and including December 1, 2014.

Alderman  _____

Deborah Mell 33rd Ward



Department of Business Affairs and Consumer Protection

Small Business Center - Public Way Use Unit

City Hall - 121 N. LaSalle Street, Room 800 • Chicago, IL 60602

(312)-74-GOBIZ (312-744-6249) • (312) 744-1944 (TTY)

<http://www.cityofchicago.org/bacp>

05/28/2014

Alderman **Deborah Mell**

Ward # **33**

City of Chicago

City Hall, Room **208**

121 North LaSalle Street

Chicago, Illinois 60602

Re: An ordinance to use and maintain a portion of the public right-of-way for **one (1) sidewalk cafe(s)** for **ANTOJITOS MAJICOS**, adjacent to the premises known as **3540 W. Lawrence Ave.**.

Dear Alderman **Deborah Mell**:

The applicant referenced above has requested the use of the public right-of-way for a **sidewalk cafe(s)**. An ordinance has been prepared by the Department of Business Affairs and Consumer Protection – Small Business Center - Public Way Use Unit for presentation to the City Council. Because this request was made for properties located in your ward, as approved by you as per the attached, I respectfully request that you introduce the attached ordinance at the next City Council meeting.

If you have any questions regarding this ordinance, please contact Anthony Bertuca at (312) 744-5506.

Department of Business Affairs and Consumer Protection



City of Chicago



O2014-4455

Office of the City Clerk

Document Tracking Sheet

| | |
|---------------------------------|---|
| Meeting Date: | 5/28/2014 |
| Sponsor(s): | Colón (35) |
| Type: | Ordinance |
| Title: | Sidewalk cafe(s) for Alaska Paleteria Y Neveria |
| Committee(s) Assignment: | Committee on Transportation and Public Way |

ORDINANCE
ALASKA PALETERIA Y NEVERIA
Acct. No. 361506 - 1
Permit No. 1113271

Be It Ordained by the City Council of the City of Chicago:

Permission and authority are hereby given and granted to ALASKA PALETERIA Y NEVERIA upon the terms and subject to the conditions of this ordinance, to maintain and use a portion of the public right of way for a sidewalk cafe adjacent to its premises located at 3446 W. Irving Park Rd.. Said sidewalk cafe area #1 shall be twenty-two point two five (22.25) feet in length and four point five (4.5) feet in width for a total of one hundred point one three (100.13) square feet and shall allow six (6) feet of clear space from the face of the curb/building line along W. Irving Park Road. The compensation for said space and the days and hours of operation for the sidewalk cafe shall be as follows:

Monday through Sunday 10:00 a.m. to 10:00 p.m.
Compensation: \$600.00
SEATING CAPACITY: 12

Sidewalk Cafe Permit and approved plan must be posted at all times.

This grant of privilege #1113271 for a sidewalk cafe shall be subject to the provisions of Section 10-28-800 through 10-28-885 of the Municipal Code of Chicago and the directions of the Commissioner of Department of Business Affairs and Consumer Protection, the Commissioner of Streets and Sanitation, and the Commissioner of Transportation.

The permit holder agrees to hold the City of Chicago harmless for any damage, relocation or replacement costs associated with damage, relocation or removal of private property caused by the City performing work in the public way.

Authority for the above named privilege is herein given and granted from and after March 1, 2014 through and including December 1, 2014.

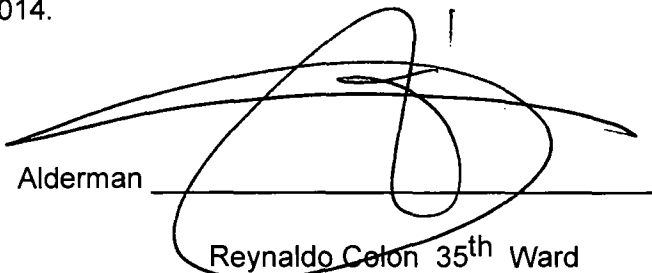
Alderman _____

Reynaldo Colon 35th Ward



05/28/2014

Alderman Reynaldo Colon
Ward # **35**
City of Chicago
City Hall, Room **203**
121 North LaSalle Street
Chicago, Illinois 60602

Re: An ordinance to use and maintain a portion of the public right-of-way for **one (1) sidewalk cafe(s)** for **ALASKA PALETERIA Y NEVERIA**, adjacent to the premises known as **3446 W. Irving Park Rd.**

Dear Alderman **Reynaldo Colon**:

The applicant referenced above has requested the use of the public right-of-way for a **sidewalk cafe(s)**. An ordinance has been prepared by the Department of Business Affairs and Consumer Protection – Small Business Center - Public Way Use Unit for presentation to the City Council. Because this request was made for properties located in your ward, as approved by you as per the attached, I respectfully request that you introduce the attached ordinance at the next City Council meeting.

If you have any questions regarding this ordinance, please contact Anthony Bertuca at (312) 744-5506.

Department of Business Affairs and Consumer Protection



City of Chicago



O2014-4457

Office of the City Clerk

Document Tracking Sheet

| | |
|---------------------------------|--|
| Meeting Date: | 5/28/2014 |
| Sponsor(s): | Colón (35) |
| Type: | Ordinance |
| Title: | Sidewalk cafe(s) for Logan Theatre, The |
| Committee(s) Assignment: | Committee on Transportation and Public Way |

ORDINANCE
THE LOGAN THEATRE
Acct. No. 356299 - 2
Permit No. 1113290

Be It Ordained by the City Council of the City of Chicago:

Permission and authority are hereby given and granted to THE LOGAN THEATRE upon the terms and subject to the conditions of this ordinance, to maintain and use a portion of the public right of way for a sidewalk cafe adjacent to its premises located at 2646-2648 N. Milwaukee Ave.. Said sidewalk cafe area #1 shall be twenty-eight point eight three (28.83) feet in length and four point eight three (4.83) feet in width for a total of one hundred thirty-nine point two five (139.25) square feet and shall allow six (6) feet of clear space from the face of the curb/building line along N. Milwaukee. The compensation for said space and the days and hours of operation for the sidewalk cafe shall be as follows:

Monday-Sunday 10:00 am to 12:00 am
Compensation: \$600.00
SEATING CAPACITY: 20

Sidewalk Cafe Permit and approved plan must be posted at all times.

This grant of privilege #1113290 for a sidewalk cafe shall be subject to the provisions of Section 10-28-800 through 10-28-885 of the Municipal Code of Chicago and the directions of the Commissioner of Department of Business Affairs and Consumer Protection, the Commissioner of Streets and Sanitation, and the Commissioner of Transportation.

The permit holder agrees to hold the City of Chicago harmless for any damage, relocation or replacement costs associated with damage, relocation or removal of private property caused by the City performing work in the public way.

Authority for the above named privilege is herein given and granted from and after March 1, 2014 through and including December 1, 2014.

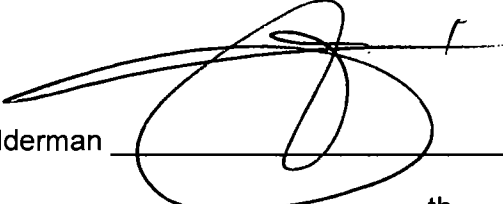
Alderman _____

Reynaldo Colon 35th Ward



05/28/2014

Alderman **Reynaldo Colon**
Ward # **35**
City of Chicago
City Hall, Room **203**
121 North LaSalle Street
Chicago, Illinois 60602

Re: An ordinance to use and maintain a portion of the public right-of-way for **one (1) sidewalk cafe(s)** for **THE LOGAN THEATRE**, adjacent to the premises known as **2646-2648 N. Milwaukee Ave.**.

Dear Alderman **Reynaldo Colon**:

The applicant referenced above has requested the use of the public right-of-way for a **sidewalk cafe(s)**. An ordinance has been prepared by the Department of Business Affairs and Consumer Protection – Small Business Center - Public Way Use Unit for presentation to the City Council. Because this request was made for properties located in your ward, as approved by you as per the attached, I respectfully request that you introduce the attached ordinance at the next City Council meeting.

If you have any questions regarding this ordinance, please contact Anthony Bertuca at (312) 744-5506.

Department of Business Affairs and Consumer Protection



City of Chicago



O2014-4460

Office of the City Clerk

Document Tracking Sheet

| | |
|---------------------------------|--|
| Meeting Date: | 5/28/2014 |
| Sponsor(s): | Colón (35) |
| Type: | Ordinance |
| Title: | Sidewalk cafe(s) for Osteria Langhe |
| Committee(s) Assignment: | Committee on Transportation and Public Way |

ORDINANCE
OSTERIA LANGHE
Acct. No. 346165 - 1
Permit No. 1113253

Be It Ordained by the City Council of the City of Chicago:

Permission and authority are hereby given and granted to OSTERIA LANGHE upon the terms and subject to the conditions of this ordinance, to maintain and use a portion of the public right of way for a sidewalk cafe adjacent to its premises located at 2824 W. Armitage Ave.. Said sidewalk cafe area #1 shall be twenty-two point zero eight (22.08) feet in length and four point five (4.5) feet in width for a total of ninety-nine point three six (99.36) square feet and shall allow six (6) feet of clear space from the face of the curb/building line along W. Armitage Avenue. The compensation for said space and the days and hours of operation for the sidewalk cafe shall be as follows:

Monday through Friday 5:00 p.m. to 10:00 p.m. Saturday 5:00 p.m. to 11:00 p.m.
Sunday 12:00 noon to 9:00 p.m.
Compensation: \$600.00
SEATING CAPACITY: 12

Sidewalk Cafe Permit and approved plan must be posted at all times.

This grant of privilege #1113253 for a sidewalk cafe shall be subject to the provisions of Section 10-28-800 through 10-28-885 of the Municipal Code of Chicago and the directions of the Commissioner of Department of Business Affairs and Consumer Protection, the Commissioner of Streets and Sanitation, and the Commissioner of Transportation.

The permit holder agrees to hold the City of Chicago harmless for any damage, relocation or replacement costs associated with damage, relocation or removal of private property caused by the City performing work in the public way.

Authority for the above named privilege is herein given and granted from and after March 1, 2014 through and including December 1, 2014.

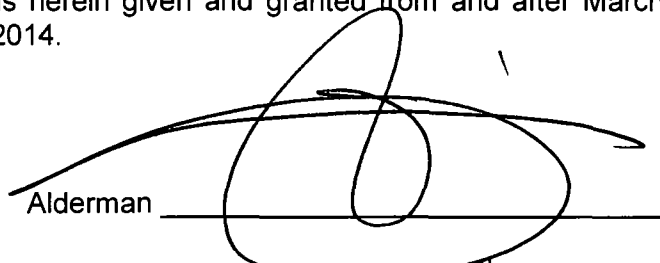
Alderman _____
Reynaldo Colon 35th Ward



05/28/2014

Alderman **Reynaldo Colon**
Ward # **35**
City of Chicago
City Hall, Room **203**
121 North LaSalle Street
Chicago, Illinois 60602

Re: An ordinance to use and maintain a portion of the public right-of-way for **one (1) sidewalk cafe(s)** for **OSTERIA LANGHE**, adjacent to the premises known as **2824 W. Armitage Ave.**

Dear Alderman **Reynaldo Colon**:

The applicant referenced above has requested the use of the public right-of-way for a **sidewalk cafe(s)**. An ordinance has been prepared by the Department of Business Affairs and Consumer Protection – Small Business Center - Public Way Use Unit for presentation to the City Council. Because this request was made for properties located in your ward, as approved by you as per the attached, I respectfully request that you introduce the attached ordinance at the next City Council meeting.

If you have any questions regarding this ordinance, please contact Anthony Bertuca at (312) 744-5506.

Department of Business Affairs and Consumer Protection



City of Chicago



O2014-4464

Office of the City Clerk

Document Tracking Sheet

| | |
|---------------------------------|--|
| Meeting Date: | 5/28/2014 |
| Sponsor(s): | Sposato (36) |
| Type: | Ordinance |
| Title: | Sidewalk cafe(s) for Caffè Italia |
| Committee(s) Assignment: | Committee on Transportation and Public Way |

ORDINANCE
CAFFE ITALIA
Acct. No. 4461 - 1
Permit No. 1113165

Be It Ordained by the City Council of the City of Chicago:

Permission and authority are hereby given and granted to CAFFE ITALIA upon the terms and subject to the conditions of this ordinance, to maintain and use a portion of the public right of way for a sidewalk cafe adjacent to its premises located at 2625 N. Harlem Ave.. Said sidewalk cafe area #1 shall be fifty (50) feet in length and seven point five (7.5) feet in width for a total of three hundred seventy-five (375) square feet and shall allow six (6) feet of clear space from the face of the curb/building line along N Harlem Ave. The compensation for said space and the days and hours of operation for the sidewalk cafe shall be as follows:

Sunday through Saturday 8:00 a.m. until 12:00 Midnight
Compensation: \$600.00
SEATING CAPACITY: 20

Sidewalk Cafe Permit and approved plan must be posted at all times.

This grant of privilege #1113165 for a sidewalk cafe shall be subject to the provisions of Section 10-28-800 through 10-28-885 of the Municipal Code of Chicago and the directions of the Commissioner of Department of Business Affairs and Consumer Protection, the Commissioner of Streets and Sanitation, and the Commissioner of Transportation.

The permit holder agrees to hold the City of Chicago harmless for any damage, relocation or replacement costs associated with damage, relocation or removal of private property caused by the City performing work in the public way.

Authority for the above named privilege is herein given and granted from and after March 1, 2014 through and including December 1, 2014.

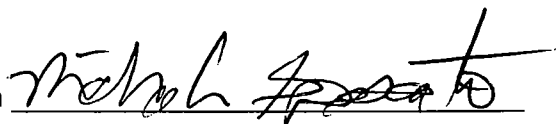
Alderman 

Nicholas Sposato 36th Ward



05/28/2014

Alderman **Nicholas Sposato**
Ward # **36**
City of Chicago
City Hall, Room **304**
121 North LaSalle Street
Chicago, Illinois 60602

Re: An ordinance to use and maintain a portion of the public right-of-way for **one (1) sidewalk cafe(s)** for **CAFFE ITALIA**, adjacent to the premises known as **2625 N. Harlem Ave.**.

Dear Alderman **Nicholas Sposato**:

The applicant referenced above has requested the use of the public right-of-way for a **sidewalk cafe(s)**. An ordinance has been prepared by the Department of Business Affairs and Consumer Protection – Small Business Center - Public Way Use Unit for presentation to the City Council. Because this request was made for properties located in your ward, as approved by you as per the attached, I respectfully request that you introduce the attached ordinance at the next City Council meeting.

If you have any questions regarding this ordinance, please contact Anthony Bertuca at (312) 744-5506.

Department of Business Affairs and Consumer Protection



City of Chicago



O2014-4468

Office of the City Clerk

Document Tracking Sheet

| | |
|---------------------------------|--|
| Meeting Date: | 5/28/2014 |
| Sponsor(s): | Sposato (36) |
| Type: | Ordinance |
| Title: | Sidewalk cafe(s) for Euro Cafe |
| Committee(s) Assignment: | Committee on Transportation and Public Way |

ORDINANCE
EURO CAFE'
Acct. No. 274855 - 1
Permit No. 1111832

Be It Ordained by the City Council of the City of Chicago:

Permission and authority are hereby given and granted to EURO CAFE' upon the terms and subject to the conditions of this ordinance, to maintain and use a portion of the public right of way for a sidewalk cafe adjacent to its premises located at 3435 N. Harlem Ave.. Said sidewalk cafe area #1 shall be eighteen (18) feet in length and three (3) feet in width for a total of fifty-four (54) square feet and shall allow six (6) feet of clear space from the face of the curb/building line along N. Harlem Avenue. The compensation for said space and the days and hours of operation for the sidewalk cafe shall be as follows:

Monday through Sunday 8:00 a.m. to 11:00 p.m.
Compensation: \$600.00
SEATING CAPACITY: 16

Sidewalk Cafe Permit and approved plan must be posted at all times.

This grant of privilege #1111832 for a sidewalk cafe shall be subject to the provisions of Section 10-28-800 through 10-28-885 of the Municipal Code of Chicago and the directions of the Commissioner of Department of Business Affairs and Consumer Protection, the Commissioner of Streets and Sanitation, and the Commissioner of Transportation.

The permit holder agrees to hold the City of Chicago harmless for any damage, relocation or replacement costs associated with damage, relocation or removal of private property caused by the City performing work in the public way.

Authority for the above named privilege is herein given and granted from and after March 1, 2014 through and including December 1, 2014.

Alderman 
Nicholas Sposato 36th Ward



05/28/2014

Alderman **Nicholas Sposato**
Ward # **36**
City of Chicago
City Hall, Room **304**
121 North LaSalle Street
Chicago, Illinois 60602

Re: An ordinance to use and maintain a portion of the public right-of-way for **one (1) sidewalk cafe(s)** for **EURO CAFE'**, adjacent to the premises known as **3435 N. Harlem Ave.**.

Dear Alderman **Nicholas Sposato**:

The applicant referenced above has requested the use of the public right-of-way for a **sidewalk cafe(s)**. An ordinance has been prepared by the Department of Business Affairs and Consumer Protection – Small Business Center - Public Way Use Unit for presentation to the City Council. Because this request was made for properties located in your ward, as approved by you as per the attached, I respectfully request that you introduce the attached ordinance at the next City Council meeting.

If you have any questions regarding this ordinance, please contact Anthony Bertuca at (312) 744-5506.

Department of Business Affairs and Consumer Protection



City of Chicago



O2014-4471

Office of the City Clerk
Document Tracking Sheet

| | |
|---------------------------------|--|
| Meeting Date: | 5/28/2014 |
| Sponsor(s): | Cullerton (38) |
| Type: | Ordinance |
| Title: | Sidewalk cafe(s) for Leadbelly |
| Committee(s) Assignment: | Committee on Transportation and Public Way |

ORDINANCE
LEADBELLY
Acct. No. 377743 - 1
Permit No. 1113252

Be It Ordained by the City Council of the City of Chicago:

Permission and authority are hereby given and granted to LEADBELLY upon the terms and subject to the conditions of this ordinance, to maintain and use a portion of the public right of way for a sidewalk cafe adjacent to its premises located at 5739 W. Irving Park Rd.. Said sidewalk cafe area #1 shall be twenty-five (25) feet in length and twelve (12) feet in width for a total of three hundred (300) square feet and shall allow six (6) feet of clear space from the face of the curb/building line along W. Irving Park Road. The compensation for said space and the days and hours of operation for the sidewalk cafe shall be as follows:

Tuesday through Thursday 5:00 p.m. to 9:00 p.m. Friday and Saturday 5:00 p.m. to 10:00 p.m. Sunday 12:00 p.m. to 7:00 p.m.
Compensation: \$600.00
SEATING CAPACITY: 14

Sidewalk Cafe Permit and approved plan must be posted at all times.

This grant of privilege #1113252 for a sidewalk cafe shall be subject to the provisions of Section 10-28-800 through 10-28-885 of the Municipal Code of Chicago and the directions of the Commissioner of Department of Business Affairs and Consumer Protection, the Commissioner of Streets and Sanitation, and the Commissioner of Transportation.

The permit holder agrees to hold the City of Chicago harmless for any damage, relocation or replacement costs associated with damage, relocation or removal of private property caused by the City performing work in the public way.

Authority for the above named privilege is herein given and granted from and after March 1, 2014 through and including December 1, 2014.

Alderman  _____

Timothy Cullerton 38th Ward



City of Chicago



O2014-4477

Office of the City Clerk

Document Tracking Sheet

| | |
|---------------------------------|---|
| Meeting Date: | 5/28/2014 |
| Sponsor(s): | Laurino (39) |
| Type: | Ordinance |
| Title: | Sidewalk cafe(s) for El Restaurante Tinajon |
| Committee(s) Assignment: | Committee on Transportation and Public Way |

ORDINANCE
EL RESTAURANTE TINAJON
Acct. No. 385006 - 1
Permit No. 1113162

Be It Ordained by the City Council of the City of Chicago:

Permission and authority are hereby given and granted to EL RESTAURANTE TINAJON upon the terms and subject to the conditions of this ordinance, to maintain and use a portion of the public right of way for a sidewalk cafe adjacent to its premises located at 4425 W. Montrose Ave.. Said sidewalk cafe area #1 shall be thirty-nine point five (39.5) feet in length and nine point five (9.5) feet in width for a total of three hundred seventy-five point two five (375.25) square feet and shall allow six (6) feet of clear space from the face of the curb/building line along N. Kenneth. The compensation for said space and the days and hours of operation for the sidewalk cafe shall be as follows:

Saturday and Sunday 10:00 a.m. to 10:00 p.m. Monday, Wednesday through Friday
11:00 a.m. to 10:00 p.m. closed on Tuesday
Compensation: \$600.00
SEATING CAPACITY: 32

Sidewalk Cafe Permit and approved plan must be posted at all times.

This grant of privilege #1113162 for a sidewalk cafe shall be subject to the provisions of Section 10-28-800 through 10-28-885 of the Municipal Code of Chicago and the directions of the Commissioner of Department of Business Affairs and Consumer Protection, the Commissioner of Streets and Sanitation, and the Commissioner of Transportation.

The permit holder agrees to hold the City of Chicago harmless for any damage, relocation or replacement costs associated with damage, relocation or removal of private property caused by the City performing work in the public way.

Authority for the above named privilege is herein given and granted from and after March 1, 2014 through and including December 1, 2014.

Alderman 

Margaret Laurino 39th Ward



City of Chicago



O2014-4481

Office of the City Clerk

Document Tracking Sheet

| | |
|---------------------------------|--|
| Meeting Date: | 5/28/2014 |
| Sponsor(s): | O'Connor (40) |
| Type: | Ordinance |
| Title: | Sidewalk cafe(s) for Sunset Caffe |
| Committee(s) Assignment: | Committee on Transportation and Public Way |

ORDINANCE
SUNSET CAFFE
Acct. No. 270743 - 1
Permit No. 1113243

Be It Ordained by the City Council of the City of Chicago:

Permission and authority are hereby given and granted to SUNSET CAFFE upon the terms and subject to the conditions of this ordinance, to maintain and use a portion of the public right of way for a sidewalk cafe adjacent to its premises located at 5726 N. Western Ave.. Said sidewalk cafe area #1 shall be twenty-five (25) feet in length and eleven (11) feet in width for a total of two hundred seventy-five (275) square feet and shall allow six (6) feet of clear space from the face of the curb/building line along N. Western. The compensation for said space and the days and hours of operation for the sidewalk cafe shall be as follows:

Sunday through Thursday 8:00 a.m. to 10:00 p.m. Friday and Saturday 8:00 a.m. to 11:00 p.m.
Compensation: \$600.00
SEATING CAPACITY: 24

Sidewalk Cafe Permit and approved plan must be posted at all times.

This grant of privilege #1113243 for a sidewalk cafe shall be subject to the provisions of Section 10-28-800 through 10-28-885 of the Municipal Code of Chicago and the directions of the Commissioner of Department of Business Affairs and Consumer Protection, the Commissioner of Streets and Sanitation, and the Commissioner of Transportation.

The permit holder agrees to hold the City of Chicago harmless for any damage, relocation or replacement costs associated with damage, relocation or removal of private property caused by the City performing work in the public way.

Authority for the above named privilege is herein given and granted from and after March 1, 2014 through and including December 1, 2014.

Alderman

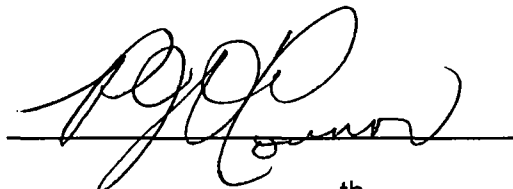
A handwritten signature in black ink, appearing to read "Patrick O'Connor", written over a horizontal line.

Patrick O'Connor 40th Ward



05/28/2014

Alderman **Patrick O'Connor**
Ward # **40**
City of Chicago
City Hall, Room **305**
121 North LaSalle Street
Chicago, Illinois 60602

Re: An ordinance to use and maintain a portion of the public right-of-way for **one (1) sidewalk cafe(s)** for **SUNSET CAFFE**, adjacent to the premises known as **5726 N. Western Ave.**.

Dear Alderman **Patrick O'Connor**:

The applicant referenced above has requested the use of the public right-of-way for a **sidewalk cafe(s)**. An ordinance has been prepared by the Department of Business Affairs and Consumer Protection – Small Business Center - Public Way Use Unit for presentation to the City Council. Because this request was made for properties located in your ward, as approved by you as per the attached, I respectfully request that you introduce the attached ordinance at the next City Council meeting.

If you have any questions regarding this ordinance, please contact Anthony Bertuca at (312) 744-5506.

Department of Business Affairs and Consumer Protection



City of Chicago



O2014-4505

Office of the City Clerk

Document Tracking Sheet

| | |
|---------------------------------|--|
| Meeting Date: | 5/28/2014 |
| Sponsor(s): | Reilly (42) |
| Type: | Ordinance |
| Title: | Sidewalk cafe(s) for Chicago French Market |
| Committee(s) Assignment: | Committee on Transportation and Public Way |

ORDINANCE
CHICAGO FRENCH MARKET
Acct. No. 314785 - 1
Permit No. 1113266

Be It Ordained by the City Council of the City of Chicago:

Permission and authority are hereby given and granted to CHICAGO FRENCH MARKET upon the terms and subject to the conditions of this ordinance, to maintain and use a portion of the public right of way for a sidewalk cafe adjacent to its premises located at 131 N. Clinton St.. Said sidewalk cafe area #1 shall be sixteen (16) feet in length and eleven point zero two (11.02) feet in width, area #2 shall be nine (9) feet in length and eleven point zero two (11.02) feet in width for a total of two hundred seventy-five point five (275.5) square feet and shall allow six (6) feet of clear space from the face of the curb/building line along N. Clinton. The compensation for said space and the days and hours of operation for the sidewalk cafe shall be as follows:

Monday through Friday 8:00 a.m. to 7:30 p.m. Saturday 8:00 a.m. to 5:30 p.m.
Compensation: \$600.00
SEATING CAPACITY: 20

Sidewalk Cafe Permit and approved plan must be posted at all times.

This grant of privilege #1113266 for a sidewalk cafe shall be subject to the provisions of Section 10-28-800 through 10-28-885 of the Municipal Code of Chicago and the directions of the Commissioner of Department of Business Affairs and Consumer Protection, the Commissioner of Streets and Sanitation, and the Commissioner of Transportation.

The permit holder agrees to hold the City of Chicago harmless for any damage, relocation or replacement costs associated with damage, relocation or removal of private property caused by the City performing work in the public way.

Authority for the above named privilege is herein given and granted from and after March 1, 2014 through and including December 1, 2014.

Alderman _____

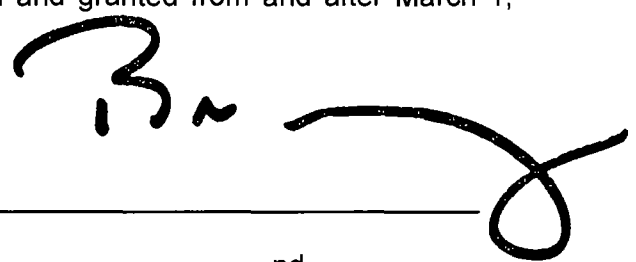

Brendan Reilly 42nd Ward



City of Chicago



O2014-4508

Office of the City Clerk

Document Tracking Sheet

| | |
|---------------------------------|--|
| Meeting Date: | 5/28/2014 |
| Sponsor(s): | Reilly (42) |
| Type: | Ordinance |
| Title: | Sidewalk cafe(s) for Corner Bakery Cafe |
| Committee(s) Assignment: | Committee on Transportation and Public Way |

ORDINANCE
CORNER BAKERY CAFE
Acct. No. 298727 - 11
Permit No. 1112978

Be It Ordained by the City Council of the City of Chicago:

Permission and authority are hereby given and granted to CORNER BAKERY CAFE upon the terms and subject to the conditions of this ordinance, to maintain and use a portion of the public right of way for a sidewalk cafe adjacent to its premises located at 360 N. Michigan Ave.. Said sidewalk cafe area #1 shall be seventy point one seven (70.17) feet in length and twelve point four two (12.42) feet in width for a total of eight hundred seventy-one point five one (871.51) square feet and shall allow six (6) feet of clear space from the face of the curb/building line along N. Wacker. The compensation for said space and the days and hours of operation for the sidewalk cafe shall be as follows:

Monday through Sunday 8:00 a.m. to 8:00 p.m.
Compensation: \$3,921.80
SEATING CAPACITY: 60

Sidewalk Cafe Permit and approved plan must be posted at all times.

This grant of privilege #1112978 for a sidewalk cafe shall be subject to the provisions of Section 10-28-800 through 10-28-885 of the Municipal Code of Chicago and the directions of the Commissioner of Department of Business Affairs and Consumer Protection, the Commissioner of Streets and Sanitation, and the Commissioner of Transportation.

The permit holder agrees to hold the City of Chicago harmless for any damage, relocation or replacement costs associated with damage, relocation or removal of private property caused by the City performing work in the public way.

Authority for the above named privilege is herein given and granted from and after March 1, 2014 through and including December 1, 2014.

Alderman _____

Brendan Reilly 42nd Ward

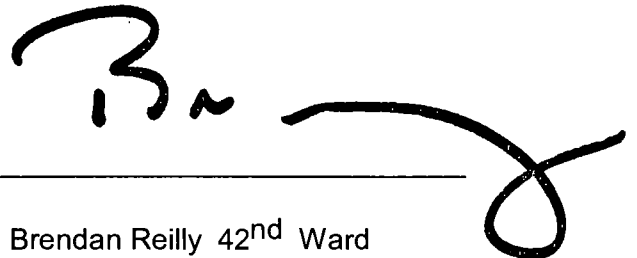
A handwritten signature in black ink, appearing to read 'B. Reilly', with a long horizontal stroke extending to the right and a loop at the end.

Handwritten scribbles and marks at the bottom of the page.



City of Chicago



O2014-4521

Office of the City Clerk

Document Tracking Sheet

| | |
|---------------------------------|--|
| Meeting Date: | 5/28/2014 |
| Sponsor(s): | Reilly (42) |
| Type: | Ordinance |
| Title: | Sidewalk cafe(s) for Dunkin Donuts - 100 W Randolph St |
| Committee(s) Assignment: | Committee on Transportation and Public Way |

ORDINANCE
Dunkin Donuts
Acct. No. 350845 - 1
Permit No. 1113260

Be It Ordained by the City Council of the City of Chicago:

Permission and authority are hereby given and granted to Dunkin Donuts upon the terms and subject to the conditions of this ordinance, to maintain and use a portion of the public right of way for a sidewalk cafe adjacent to its premises located at 100 W. Randolph St.. Said sidewalk cafe area #1 shall be fourteen (14) feet in length and nine (9) feet in width for a total of one hundred twenty-six (126) square feet and shall allow six (6) feet of clear space from the face of the curb/building line along N. Lake. The compensation for said space and the days and hours of operation for the sidewalk cafe shall be as follows:

Sunday through Saturday 8:00am until 7:00pm
Compensation: \$600.00
SEATING CAPACITY: 8

Sidewalk Cafe Permit and approved plan must be posted at all times.

This grant of privilege #1113260 for a sidewalk cafe shall be subject to the provisions of Section 10-28-800 through 10-28-885 of the Municipal Code of Chicago and the directions of the Commissioner of Department of Business Affairs and Consumer Protection, the Commissioner of Streets and Sanitation, and the Commissioner of Transportation.

The permit holder agrees to hold the City of Chicago harmless for any damage, relocation or replacement costs associated with damage, relocation or removal of private property caused by the City performing work in the public way.

Authority for the above named privilege is herein given and granted from and after March 1, 2014 through and including December 1, 2014.

Alderman _____

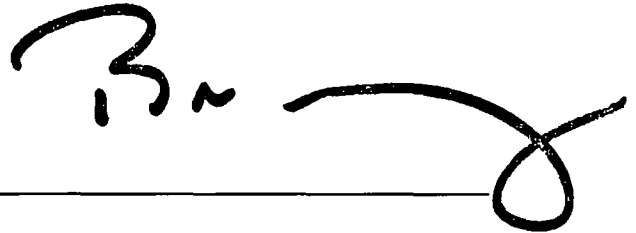

Brendan Reilly 42nd Ward



City of Chicago



O2014-4522

Office of the City Clerk

Document Tracking Sheet

| | |
|---------------------------------|--|
| Meeting Date: | 5/28/2014 |
| Sponsor(s): | Reilly (42) |
| Type: | Ordinance |
| Title: | Sidewalk cafe(s) for Dunkin Donuts - 223 W Washington St |
| Committee(s) Assignment: | Committee on Transportation and Public Way |

ORDINANCE
Dunkin Donuts
Acct. No. 350847 - 3
Permit No. 1113262

Be It Ordained by the City Council of the City of Chicago:

Permission and authority are hereby given and granted to Dunkin Donuts upon the terms and subject to the conditions of this ordinance, to maintain and use a portion of the public right of way for a sidewalk cafe adjacent to its premises located at 223 W. Washington St.. Said sidewalk cafe area #1 shall be twenty-one point five (21.5) feet in length and ten (10) feet in width for a total of two hundred fifteen (215) square feet and shall allow six (6) feet of clear space from the face of the curb/building line along W. Washington Street. The compensation for said space and the days and hours of operation for the sidewalk cafe shall be as follows:

Monday through Sunday 8:00 a.m. to 10:00 p.m.
Compensation: \$967.50
SEATING CAPACITY: 8

Sidewalk Cafe Permit and approved plan must be posted at all times.

This grant of privilege #1113262 for a sidewalk cafe shall be subject to the provisions of Section 10-28-800 through 10-28-885 of the Municipal Code of Chicago and the directions of the Commissioner of Department of Business Affairs and Consumer Protection, the Commissioner of Streets and Sanitation, and the Commissioner of Transportation.

The permit holder agrees to hold the City of Chicago harmless for any damage, relocation or replacement costs associated with damage, relocation or removal of private property caused by the City performing work in the public way.

Authority for the above named privilege is herein given and granted from and after March 1, 2014 through and including December 1, 2014.

Alderman _____

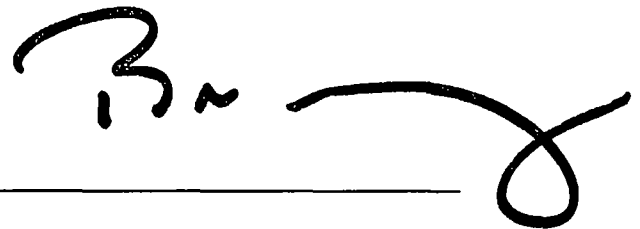

Brendan Reilly 42nd Ward

Handwritten text, possibly a signature or date, located in the lower-left corner of the page.



City of Chicago



O2014-4528

Office of the City Clerk

Document Tracking Sheet

| | |
|---------------------------------|--|
| Meeting Date: | 5/28/2014 |
| Sponsor(s): | Reilly (42) |
| Type: | Ordinance |
| Title: | Sidewalk cafe(s) for Dunkin Donuts - 205 W Randolph St |
| Committee(s) Assignment: | Committee on Transportation and Public Way |

ORDINANCE
Dunkin Donuts
Acct. No. 350846 - 1
Permit No. 1113263

Be It Ordained by the City Council of the City of Chicago:

Permission and authority are hereby given and granted to Dunkin Donuts upon the terms and subject to the conditions of this ordinance, to maintain and use a portion of the public right of way for a sidewalk cafe adjacent to its premises located at 205 W. Randolph St.. Said sidewalk cafe area #1 shall be twenty (20) feet in length and seven (7) feet in width for a total of one hundred forty (140) square feet and shall allow six (6) feet of clear space from the face of the curb/building line along N. Wells. The compensation for said space and the days and hours of operation for the sidewalk cafe shall be as follows:

Sunday through Saturday 8:00am until 10:00pm
Compensation: \$630.00
SEATING CAPACITY: 6

Sidewalk Cafe Permit and approved plan must be posted at all times.

This grant of privilege #1113263 for a sidewalk cafe shall be subject to the provisions of Section 10-28-800 through 10-28-885 of the Municipal Code of Chicago and the directions of the Commissioner of Department of Business Affairs and Consumer Protection, the Commissioner of Streets and Sanitation, and the Commissioner of Transportation.

The permit holder agrees to hold the City of Chicago harmless for any damage, relocation or replacement costs associated with damage, relocation or removal of private property caused by the City performing work in the public way.

Authority for the above named privilege is herein given and granted from and after March 1, 2014 through and including December 1, 2014.

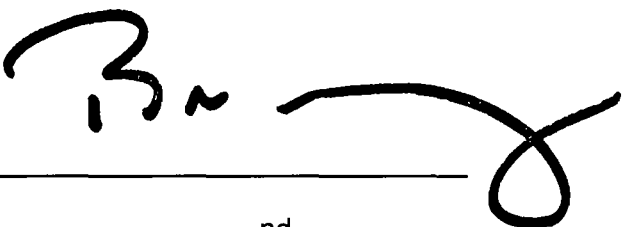
Alderman 
Brendan Reilly 42nd Ward



City of Chicago



O2014-4534

Office of the City Clerk

Document Tracking Sheet

| | |
|---------------------------------|---|
| Meeting Date: | 5/28/2014 |
| Sponsor(s): | Reilly (42) |
| Type: | Ordinance |
| Title: | Sidewalk cafe(s) for Freshii - 50 E Washington St |
| Committee(s) Assignment: | Committee on Transportation and Public Way |

ORDINANCE
FRESHII
Acct. No. 388239 - 1
Permit No. 1113297

Be It Ordained by the City Council of the City of Chicago:

Permission and authority are hereby given and granted to FRESHII upon the terms and subject to the conditions of this ordinance, to maintain and use a portion of the public right of way for a sidewalk cafe adjacent to its premises located at 50 E. Washington St.. Said sidewalk cafe area #1 shall be thirty-one point six seven (31.67) feet in length and eight point two five (8.25) feet in width for a total of two hundred sixty-one point two eight (261.28) square feet and shall allow six (6) feet of clear space from the face of the curb/building line along E. Washington Street. The compensation for said space and the days and hours of operation for the sidewalk cafe shall be as follows:

Monday through Friday 8:00 a.m. to 10:00 p.m. Saturday and Sunday 8:00 a.m. to 8:00 p.m.
Compensation: \$1,175.75
SEATING CAPACITY: 12

Sidewalk Cafe Permit and approved plan must be posted at all times.

This grant of privilege #1113297 for a sidewalk cafe shall be subject to the provisions of Section 10-28-800 through 10-28-885 of the Municipal Code of Chicago and the directions of the Commissioner of Department of Business Affairs and Consumer Protection, the Commissioner of Streets and Sanitation, and the Commissioner of Transportation.

The permit holder agrees to hold the City of Chicago harmless for any damage, relocation or replacement costs associated with damage, relocation or removal of private property caused by the City performing work in the public way.

Authority for the above named privilege is herein given and granted from and after March 1, 2014 through and including December 1, 2014.

Alderman _____

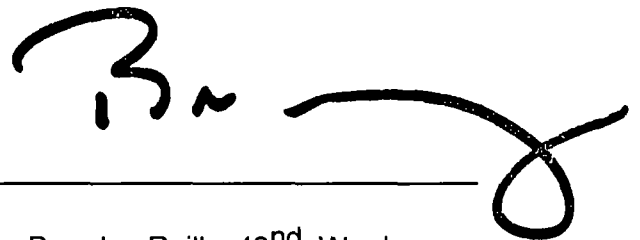

Brendan Reilly 42nd Ward



City of Chicago



O2014-4538

Office of the City Clerk

Document Tracking Sheet

| | |
|---------------------------------|---|
| Meeting Date: | 5/28/2014 |
| Sponsor(s): | Reilly (42) |
| Type: | Ordinance |
| Title: | Sidewalk cafe(s) for Freshii -200 W Randolph St |
| Committee(s) Assignment: | Committee on Transportation and Public Way |

ORDINANCE
Freshii
Acct. No. 361235 - 1
Permit No. 1112910

Be It Ordained by the City Council of the City of Chicago:

Permission and authority are hereby given and granted to Freshii upon the terms and subject to the conditions of this ordinance, to maintain and use a portion of the public right of way for a sidewalk cafe adjacent to its premises located at 200 W. Randolph St.. Said sidewalk cafe area #1 shall be nineteen (19) feet in length and four point seven five (4.75) feet in width for a total of ninety point two five (90.25) square feet and shall allow six (6) feet of clear space from the face of the curb/building line along W. Randolph Street. The compensation for said space and the days and hours of operation for the sidewalk cafe shall be as follows:

Monday through Friday 8:00 a.m. to 8:00 p.m. Saturday 8:00 a.m. to 6:00 p.m.
Compensation: \$600.00
SEATING CAPACITY: 11

Sidewalk Cafe Permit and approved plan must be posted at all times.

This grant of privilege #1112910 for a sidewalk cafe shall be subject to the provisions of Section 10-28-800 through 10-28-885 of the Municipal Code of Chicago and the directions of the Commissioner of Department of Business Affairs and Consumer Protection, the Commissioner of Streets and Sanitation, and the Commissioner of Transportation.

The permit holder agrees to hold the City of Chicago harmless for any damage, relocation or replacement costs associated with damage, relocation or removal of private property caused by the City performing work in the public way.

Authority for the above named privilege is herein given and granted from and after March 1, 2014 through and including December 1, 2014.

Alderman _____

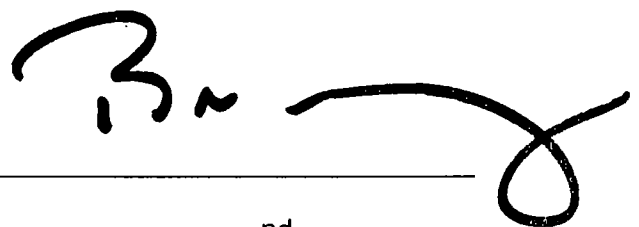

Brendan Reilly 42nd Ward

Handwritten scribbles or marks, possibly a signature or initials, located in the lower-left quadrant of the page.



City of Chicago

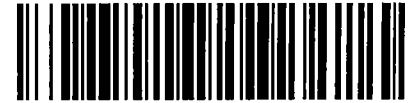

O2014-4542

Office of the City Clerk

Document Tracking Sheet

| | |
|---------------------------------|--|
| Meeting Date: | 5/28/2014 |
| Sponsor(s): | Reilly (42) |
| Type: | Ordinance |
| Title: | Sidewalk cafe(s) for Howl at the Moon |
| Committee(s) Assignment: | Committee on Transportation and Public Way |

ORDINANCE
Howl at the Moon
Acct. No. 212791 - 1
Permit No. 1113061

Be It Ordained by the City Council of the City of Chicago:

Permission and authority are hereby given and granted to Howl at the Moon upon the terms and subject to the conditions of this ordinance, to maintain and use a portion of the public right of way for a sidewalk cafe adjacent to its premises located at 26-30 W. Hubbard St.. Said sidewalk cafe area #1 shall be twenty-nine (29) feet in length and four (4) feet in width for a total of one hundred sixteen (116) square feet and shall allow six (6) feet of clear space from the face of the curb/building line along W. Hubbard Street. The compensation for said space and the days and hours of operation for the sidewalk cafe shall be as follows:

Monday through Saturday 5:00 p.m. to 12:00 a.m. Sunday 7:00 p.m. to 12:00 a.m.
Compensation: \$600.00
SEATING CAPACITY: 9

Sidewalk Cafe Permit and approved plan must be posted at all times.

This grant of privilege #1113061 for a sidewalk cafe shall be subject to the provisions of Section 10-28-800 through 10-28-885 of the Municipal Code of Chicago and the directions of the Commissioner of Department of Business Affairs and Consumer Protection, the Commissioner of Streets and Sanitation, and the Commissioner of Transportation.

The permit holder agrees to hold the City of Chicago harmless for any damage, relocation or replacement costs associated with damage, relocation or removal of private property caused by the City performing work in the public way.

Authority for the above named privilege is herein given and granted from and after March 1, 2014 through and including December 1, 2014.

Alderman _____

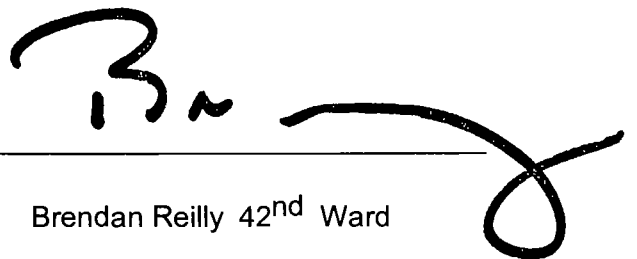

Brendan Reilly 42nd Ward



City of Chicago



O2014-4544

Office of the City Clerk

Document Tracking Sheet

| | |
|---------------------------------|--|
| Meeting Date: | 5/28/2014 |
| Sponsor(s): | Reilly (42) |
| Type: | Ordinance |
| Title: | Sidewalk cafe(s) for Jamba Juice |
| Committee(s) Assignment: | Committee on Transportation and Public Way |

ORDINANCE
JAMBA JUICE
Acct. No. 360015 - 11
Permit No. 1112911

Be It Ordained by the City Council of the City of Chicago:

Permission and authority are hereby given and granted to JAMBA JUICE upon the terms and subject to the conditions of this ordinance, to maintain and use a portion of the public right of way for a sidewalk cafe adjacent to its premises located at 20 N. Michigan Ave.. Said sidewalk cafe area #1 shall be twenty (20) feet in length and ten (10) feet in width for a total of two hundred (200) square feet and shall allow six (6) feet of clear space from the face of the curb/building line along N Michigan Ave. The compensation for said space and the days and hours of operation for the sidewalk cafe shall be as follows:

Monday through Sunday 9:00 a.m. until 10:00 p.m.
Compensation: \$900.00
SEATING CAPACITY: 15

Sidewalk Cafe Permit and approved plan must be posted at all times.

This grant of privilege #1112911 for a sidewalk cafe shall be subject to the provisions of Section 10-28-800 through 10-28-885 of the Municipal Code of Chicago and the directions of the Commissioner of Department of Business Affairs and Consumer Protection, the Commissioner of Streets and Sanitation, and the Commissioner of Transportation.

The permit holder agrees to hold the City of Chicago harmless for any damage, relocation or replacement costs associated with damage, relocation or removal of private property caused by the City performing work in the public way.

Authority for the above named privilege is herein given and granted from and after March 1, 2014 through and including December 1, 2014.

Alderman _____

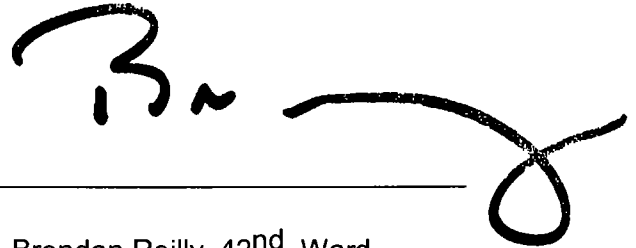

Brendan Reilly 42nd Ward

Handwritten scribbles or marks in the lower-left quadrant.

Small handwritten mark or scribble in the lower-left quadrant.



City of Chicago



O2014-4546

Office of the City Clerk

Document Tracking Sheet

| | |
|---------------------------------|--|
| Meeting Date: | 5/28/2014 |
| Sponsor(s): | Reilly (42) |
| Type: | Ordinance |
| Title: | Sidewalk cafe(s) for Jersey Mikes |
| Committee(s) Assignment: | Committee on Transportation and Public Way |

ORDINANCE
Jersey Mikes
Acct. No. 366031 - 1
Permit No. 1113261

Be It Ordained by the City Council of the City of Chicago:

Permission and authority are hereby given and granted to Jersey Mikes upon the terms and subject to the conditions of this ordinance, to maintain and use a portion of the public right of way for a sidewalk cafe adjacent to its premises located at 120 N. Wells St.. Said sidewalk cafe area #1 shall be twenty-five (25) feet in length and eight (8) feet in width for a total of two hundred (200) square feet and shall allow six (6) feet of clear space from the face of the curb/building line along N. Wells Street. The compensation for said space and the days and hours of operation for the sidewalk cafe shall be as follows:

Monday through Sunday 8:00 a.m. to 7:00 p.m.
Compensation: \$900.00
SEATING CAPACITY: 12

Sidewalk Cafe Permit and approved plan must be posted at all times.

This grant of privilege #1113261 for a sidewalk cafe shall be subject to the provisions of Section 10-28-800 through 10-28-885 of the Municipal Code of Chicago and the directions of the Commissioner of Department of Business Affairs and Consumer Protection, the Commissioner of Streets and Sanitation, and the Commissioner of Transportation.

The permit holder agrees to hold the City of Chicago harmless for any damage, relocation or replacement costs associated with damage, relocation or removal of private property caused by the City performing work in the public way.

Authority for the above named privilege is herein given and granted from and after March 1, 2014 through and including December 1, 2014.

Alderman _____

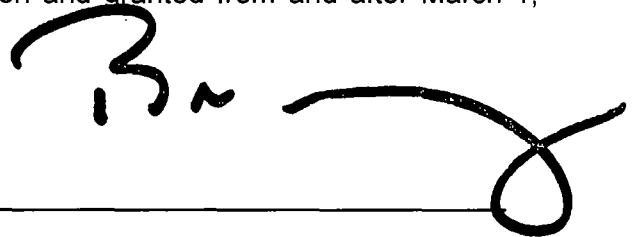

Brendan Reilly 42nd Ward



City of Chicago



O2014-4549

Office of the City Clerk Document Tracking Sheet

| | |
|---------------------------------|--|
| Meeting Date: | 5/28/2014 |
| Sponsor(s): | Reilly (42) |
| Type: | Ordinance |
| Title: | Sidewalk cafe(s) for Maggiano's Little Italy |
| Committee(s) Assignment: | Committee on Transportation and Public Way |

ORDINANCE
MAGGIANO'S LITTLE ITALY
Acct. No. 85312 - 2
Permit No. 1113256

Be It Ordained by the City Council of the City of Chicago:

Permission and authority are hereby given and granted to MAGGIANO'S LITTLE ITALY upon the terms and subject to the conditions of this ordinance, to maintain and use a portion of the public right of way for a sidewalk cafe adjacent to its premises located at 516 N. Clark St.. Said sidewalk cafe area #1 shall be sixty-five (65) feet in length and eight point nine five (8.95) feet in width, area #2 shall be sixty-seven point four two (67.42) feet in length and eight point nine five (8.95) feet in width for a total of one thousand one hundred eighty-five point one six (1185.16) square feet and shall allow six (6) feet of clear space from the face of the curb/building line along N. Clark Street, N. Clark Street. The compensation for said space and the days and hours of operation for the sidewalk cafe shall be as follows:

Monday thru Sunday 8:00 a.m. to 9:00 p.m.
Compensation: \$2,725.87
SEATING CAPACITY: 68

Sidewalk Cafe Permit and approved plan must be posted at all times.

This grant of privilege #1113256 for a sidewalk cafe shall be subject to the provisions of Section 10-28-800 through 10-28-885 of the Municipal Code of Chicago and the directions of the Commissioner of Department of Business Affairs and Consumer Protection, the Commissioner of Streets and Sanitation, and the Commissioner of Transportation.

The permit holder agrees to hold the City of Chicago harmless for any damage, relocation or replacement costs associated with damage, relocation or removal of private property caused by the City performing work in the public way.

Authority for the above named privilege is herein given and granted from and after March 1, 2014 through and including December 1, 2014.

Alderman _____



Brendan Reilly 42nd Ward



City of Chicago



O2014-4554

Office of the City Clerk

Document Tracking Sheet

| | |
|---------------------------------|---|
| Meeting Date: | 5/28/2014 |
| Sponsor(s): | Reilly (42) |
| Type: | Ordinance |
| Title: | Sidewalk cafe(s) for McCormick & Schmick's Seafood Restaurant |
| Committee(s) Assignment: | Committee on Transportation and Public Way |

ORDINANCE
MCCORMICK & SCHMICK'S SEAFOOD RESTAURANT
Acct. No. 217437 - 1
Permit No. 1113289

Be It Ordained by the City Council of the City of Chicago:

Permission and authority are hereby given and granted to MCCORMICK & SCHMICK'S SEAFOOD RESTAURANT upon the terms and subject to the conditions of this ordinance, to maintain and use a portion of the public right of way for a sidewalk cafe adjacent to its premises located at 41 E. Chestnut St.. Said sidewalk cafe area #1 shall be twenty-seven (27) feet in length and ten (10) feet in width, area #2 shall be thirty-four (34) feet in length and ten (10) feet in width for a total of six hundred ten (610) square feet and shall allow six (6) feet of clear space from the face of the curb/building line along E. Chestnut Street. The compensation for said space and the days and hours of operation for the sidewalk cafe shall be as follows:

Monday through Sunday 11:30 a.m. until 12:00 a.m. Midnight.
Compensation: \$1,403.00
SEATING CAPACITY: 46

Sidewalk Cafe Permit and approved plan must be posted at all times.

This grant of privilege #1113289 for a sidewalk cafe shall be subject to the provisions of Section 10-28-800 through 10-28-885 of the Municipal Code of Chicago and the directions of the Commissioner of Department of Business Affairs and Consumer Protection, the Commissioner of Streets and Sanitation, and the Commissioner of Transportation.

The permit holder agrees to hold the City of Chicago harmless for any damage, relocation or replacement costs associated with damage, relocation or removal of private property caused by the City performing work in the public way.

Authority for the above named privilege is herein given and granted from and after March 1, 2014 through and including December 1, 2014.

Alderman _____

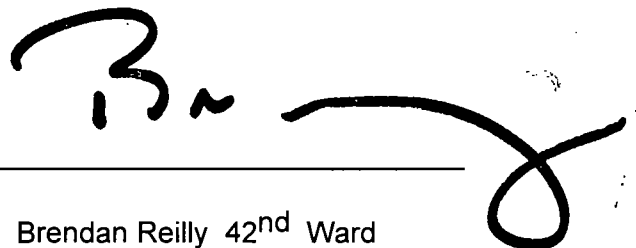

Brendan Reilly 42nd Ward

Handwritten scribbles and marks at the bottom left of the page.



City of Chicago



O2014-4555

Office of the City Clerk

Document Tracking Sheet

| | |
|---------------------------------|--|
| Meeting Date: | 5/28/2014 |
| Sponsor(s): | Reilly (42) |
| Type: | Ordinance |
| Title: | Sidewalk cafe(s) for Merlo On Maple |
| Committee(s) Assignment: | Committee on Transportation and Public Way |

ORDINANCE
MERLO ON MAPLE
Acct. No. 258766 - 1
Permit No. 1113136

Be It Ordained by the City Council of the City of Chicago:

Permission and authority are hereby given and granted to MERLO ON MAPLE upon the terms and subject to the conditions of this ordinance, to maintain and use a portion of the public right of way for a sidewalk cafe adjacent to its premises located at 16 W. Maple St.. Said sidewalk cafe area #1 shall be twenty-five (25) feet in length and ten point three (10.3) feet in width for a total of two hundred fifty-seven point five (257.5) square feet and shall allow six (6) feet of clear space from the face of the curb/building line along W. MAPLE. The compensation for said space and the days and hours of operation for the sidewalk cafe shall be as follows:

Monday thru Sunday 8:00 a.m. to 12:00 midnight
Compensation: \$600.00
SEATING CAPACITY: 22

Sidewalk Cafe Permit and approved plan must be posted at all times.

This grant of privilege #1113136 for a sidewalk cafe shall be subject to the provisions of Section 10-28-800 through 10-28-885 of the Municipal Code of Chicago and the directions of the Commissioner of Department of Business Affairs and Consumer Protection, the Commissioner of Streets and Sanitation, and the Commissioner of Transportation.

The permit holder agrees to hold the City of Chicago harmless for any damage, relocation or replacement costs associated with damage, relocation or removal of private property caused by the City performing work in the public way.

Authority for the above named privilege is herein given and granted from and after March 1, 2014 through and including December 1, 2014.

Alderman _____

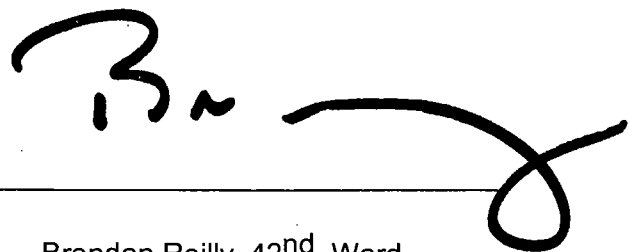

Brendan Reilly 42nd Ward

Handwritten scribbles or marks, possibly initials or a signature, located in the lower-left quadrant of the page.



City of Chicago



O2014-4559

Office of the City Clerk Document Tracking Sheet

| | |
|---------------------------------|--|
| Meeting Date: | 5/28/2014 |
| Sponsor(s): | Reilly (42) |
| Type: | Ordinance |
| Title: | Sidewalk cafe(s) for Piccolo Sogno Due |
| Committee(s) Assignment: | Committee on Transportation and Public Way |

ORDINANCE
PICCOLO SOGNO DUE
Acct. No. 368691 - 1
Permit No. 1112914

Be It Ordained by the City Council of the City of Chicago:

Permission and authority are hereby given and granted to PICCOLO SOGNO DUE upon the terms and subject to the conditions of this ordinance, to maintain and use a portion of the public right of way for a sidewalk cafe adjacent to its premises located at 340 N. Clark St.. Said sidewalk cafe area #1 shall be thirty point seven nine (30.79) feet in length and six point three three (6.33) feet in width, area #2 shall be sixteen (16) feet in length and six point three three (6.33) feet in width for a total of two hundred ninety-six point one eight (296.18) square feet and shall allow six (6) feet of clear space from the face of the curb/building line along N. Clark Street. The compensation for said space and the days and hours of operation for the sidewalk cafe shall be as follows:

Monday through Sunday 11:00 a.m. to 12:00 midnight
Compensation: \$681.22
SEATING CAPACITY: 12

Sidewalk Cafe Permit and approved plan must be posted at all times.

This grant of privilege #1112914 for a sidewalk cafe shall be subject to the provisions of Section 10-28-800 through 10-28-885 of the Municipal Code of Chicago and the directions of the Commissioner of Department of Business Affairs and Consumer Protection, the Commissioner of Streets and Sanitation, and the Commissioner of Transportation.

The permit holder agrees to hold the City of Chicago harmless for any damage, relocation or replacement costs associated with damage, relocation or removal of private property caused by the City performing work in the public way.

Authority for the above named privilege is herein given and granted from and after March 1, 2014 through and including December 1, 2014.

Alderman _____

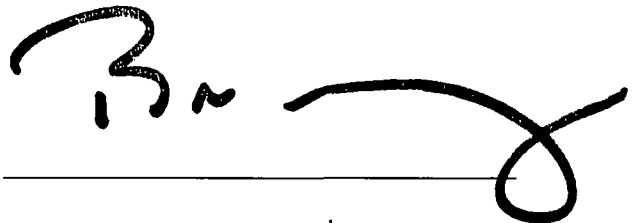

Brendan Reilly 42nd Ward



City of Chicago



O2014-4562

Office of the City Clerk

Document Tracking Sheet

| | |
|---------------------------------|---|
| Meeting Date: | 5/28/2014 |
| Sponsor(s): | Reilly (42) |
| Type: | Ordinance |
| Title: | Sidewalk cafe(s) for Pizzeria Uno Chicago Bar & Grill |
| Committee(s) Assignment: | Committee on Transportation and Public Way |

ORDINANCE
PIZZERIA UNO CHICAGO BAR & GRILL
Acct. No. 220603 - 1
Permit No. 1113287

Be It Ordained by the City Council of the City of Chicago:

Permission and authority are hereby given and granted to PIZZERIA UNO CHICAGO BAR & GRILL upon the terms and subject to the conditions of this ordinance, to maintain and use a portion of the public right of way for a sidewalk cafe adjacent to its premises located at 29 E. Ohio St.. Said sidewalk cafe area #1 shall be twenty-two point four two (22.42) feet in length and four (4) feet in width, area #2 shall be twenty-two point four two (22.42) feet in length and four (4) feet in width for a total of one hundred seventy-nine point three six (179.36) square feet and shall allow six (6) feet of clear space from the face of the curb/building line along N.WABASH. The compensation for said space and the days and hours of operation for the sidewalk cafe shall be as follows:

Monday through Sunday 10:30 a.m. to 12:00 midnight
Compensation: \$600.00
SEATING CAPACITY: 12

Sidewalk Cafe Permit and approved plan must be posted at all times.

This grant of privilege #1113287 for a sidewalk cafe shall be subject to the provisions of Section 10-28-800 through 10-28-885 of the Municipal Code of Chicago and the directions of the Commissioner of Department of Business Affairs and Consumer Protection, the Commissioner of Streets and Sanitation, and the Commissioner of Transportation.

The permit holder agrees to hold the City of Chicago harmless for any damage, relocation or replacement costs associated with damage, relocation or removal of private property caused by the City performing work in the public way.

Authority for the above named privilege is herein given and granted from and after March 1, 2014 through and including December 1, 2014.

Alderman _____

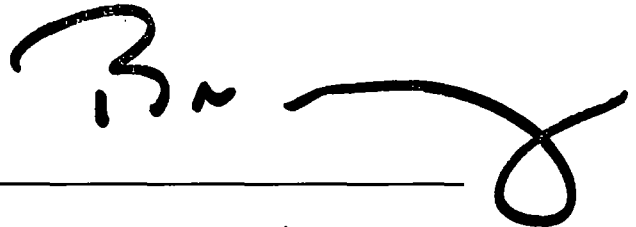

Brendan Reilly 42nd Ward

Handwritten notes or scribbles at the bottom left of the page.



City of Chicago



O2014-4570

Office of the City Clerk

Document Tracking Sheet

| | |
|---------------------------------|---|
| Meeting Date: | 5/28/2014 |
| Sponsor(s): | Reilly (42) |
| Type: | Ordinance |
| Title: | Sidewalk cafe(s) for Red Robin's Burger Works |
| Committee(s) Assignment: | Committee on Transportation and Public Way |

ORDINANCE
Red Robin's Burger Works
Acct. No. 390577 - 1
Permit No. 1113285

Be It Ordained by the City Council of the City of Chicago:

Permission and authority are hereby given and granted Red Robin's Burger Works upon the terms and subject to the conditions of this ordinance, to maintain and use a portion of the public right of way for a sidewalk cafe adjacent to its premises located at 328 N. Michigan Ave.. Said sidewalk cafe area #1 shall be twenty point six seven (20.67) feet in length and eleven point nine two (11.92) feet in width for a total of two hundred forty-six point three nine (246.39) square feet and shall allow six (6) feet of clear space from the face of the curb/building line along N. Michigan Avenue. The compensation for said space and the days and hours of operation for the sidewalk cafe shall be as follows:

Monday through Sunday 8:00 a.m. to 10:00 p.m.
Compensation: \$1,108.74
SEATING CAPACITY: 16

Sidewalk Cafe Permit and approved plan must be posted at all times.

This grant of privilege #1113285 for a sidewalk cafe shall be subject to the provisions of Section 10-28-800 through 10-28-885 of the Municipal Code of Chicago and the directions of the Commissioner of Department of Business Affairs and Consumer Protection, the Commissioner of Streets and Sanitation, and the Commissioner of Transportation.

The permit holder agrees to hold the City of Chicago harmless for any damage, relocation or replacement costs associated with damage, relocation or removal of private property caused by the City performing work in the public way.

Authority for the above named privilege is herein given and granted from and after March 1, 2014 through and including December 1, 2014.

Alderman _____

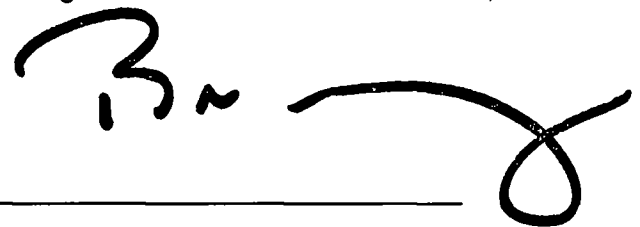

Brendan Reilly 42nd Ward



City of Chicago



O2014-4577

Office of the City Clerk

Document Tracking Sheet

| | |
|---------------------------------|---|
| Meeting Date: | 5/28/2014 |
| Sponsor(s): | Smith (43) |
| Type: | Ordinance |
| Title: | Sidewalk cafe(s) for Fiesta Mexicana Restaurant |
| Committee(s) Assignment: | Committee on Transportation and Public Way |

ORDINANCE
FIESTA MEXICANA RESTAURANT
Acct. No. 4641 - 1
Permit No. 1113139

Be It Ordained by the City Council of the City of Chicago:

Permission and authority are hereby given and granted to FIESTA MEXICANA RESTAURANT upon the terms and subject to the conditions of this ordinance, to maintain and use a portion of the public right of way for a sidewalk cafe adjacent to its premises located at 2423 N. Lincoln Ave.. Said sidewalk cafe area #1 shall be thirty-eight (38) feet in length and five (5) feet in width for a total of one hundred ninety (190) square feet and shall allow six (6) feet of clear space from the face of the curb/building line along N. Lincoln Avenue. The compensation for said space and the days and hours of operation for the sidewalk cafe shall be as follows:

Sunday through Saturday 10:00 a.m. until 12:00 Midnight
Compensation: \$600.00
SEATING CAPACITY: 20

Sidewalk Cafe Permit and approved plan must be posted at all times.

This grant of privilege #1113139 for a sidewalk cafe shall be subject to the provisions of Section 10-28-800 through 10-28-885 of the Municipal Code of Chicago and the directions of the Commissioner of Department of Business Affairs and Consumer Protection, the Commissioner of Streets and Sanitation, and the Commissioner of Transportation.

The permit holder agrees to hold the City of Chicago harmless for any damage, relocation or replacement costs associated with damage, relocation or removal of private property caused by the City performing work in the public way.

Authority for the above named privilege is herein given and granted from and after March 1, 2014 through and including December 1, 2014.

Alderman

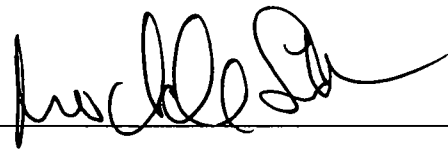

Michele Smith 43rd Ward



City of Chicago



O2014-4581

Office of the City Clerk

Document Tracking Sheet

| | |
|---------------------------------|--|
| Meeting Date: | 5/28/2014 |
| Sponsor(s): | Smith (43) |
| Type: | Ordinance |
| Title: | Sidewalk cafe(s) for Hi-Tops |
| Committee(s) Assignment: | Committee on Transportation and Public Way |

ORDINANCE

Hi-Tops

Acct. No. 16492 - 1

Permit No. 1113132

Be It Ordained by the City Council of the City of Chicago:

Permission and authority are hereby given and granted to Hi-Tops upon the terms and subject to the conditions of this ordinance, to maintain and use a portion of the public right of way for a sidewalk cafe adjacent to its premises located at 2462 N. Lincoln Ave.. Said sidewalk cafe area #1 shall be thirty-one point four two (31.42) feet in length and nine point nine two (9.92) feet in width for a total of three hundred eleven point six nine (311.69) square feet and shall allow six (6) feet of clear space from the face of the curb/building line along Montana Ave. The compensation for said space and the days and hours of operation for the sidewalk cafe shall be as follows:

Sunday 11:00 a.m. until 9:00 p.m. Monday closed Tuesday through thursday 4:00 p.m. until 9:00 p.m. Friday 4:00 p.m. until 10:00 p.m. Saturday 11:00 a.m. until 10:00 p.m.
Compensation: \$600.00
SEATING CAPACITY: 20

Sidewalk Cafe Permit and approved plan must be posted at all times.

This grant of privilege #1113132 for a sidewalk cafe shall be subject to the provisions of Section 10-28-800 through 10-28-885 of the Municipal Code of Chicago and the directions of the Commissioner of Department of Business Affairs and Consumer Protection, the Commissioner of Streets and Sanitation, and the Commissioner of Transportation.

The permit holder agrees to hold the City of Chicago harmless for any damage, relocation or replacement costs associated with damage, relocation or removal of private property caused by the City performing work in the public way.

Authority for the above named privilege is herein given and granted from and after March 1, 2014 through and including December 1, 2014.

Alderman



Michele Smith 43rd Ward



City of Chicago



O2014-4587

Office of the City Clerk

Document Tracking Sheet

| | |
|---------------------------------|--|
| Meeting Date: | 5/28/2014 |
| Sponsor(s): | Smith (43) |
| Type: | Ordinance |
| Title: | Sidewalk cafe(s) for Le Pain Quotidien |
| Committee(s) Assignment: | Committee on Transportation and Public Way |

ORDINANCE
LE PAIN QUOTIDIEN
Acct. No. 387532 - 1
Permit No. 1111922

Be It Ordained by the City Council of the City of Chicago:

Permission and authority are hereby given and granted to LE PAIN QUOTIDIEN upon the terms and subject to the conditions of this ordinance, to maintain and use a portion of the public right of way for a sidewalk cafe adjacent to its premises located at 1000-1002 W. Armitage Ave.. Said sidewalk cafe area #1 shall be nine (9) feet in length and three point one seven (3.17) feet in width, area #2 shall be nine (9) feet in length and three point one seven (3.17) feet in width, area #3 shall be eight point nine two (8.92) feet in length and three point one seven (3.17) feet in width, area #4 shall be fourteen point six seven (14.67) feet in length and three point one seven (3.17) feet in width, area #5 shall be seventeen point four two (17.42) feet in length and five point one seven (5.17) feet in width for a total of two hundred twenty-one point nine (221.9) square feet and shall allow six (6) feet of clear space from the face of the curb/building line along W. Armitage Avenue, N. Sheffield Avenue. The compensation for said space and the days and hours of operation for the sidewalk cafe shall be as follows:

Monday through Sunday 8:00 a.m. to 10:00 p.m.
Compensation: \$600.00
SEATING CAPACITY: 22

Sidewalk Cafe Permit and approved plan must be posted at all times.

This grant of privilege #1111922 for a sidewalk cafe shall be subject to the provisions of Section 10-28-800 through 10-28-885 of the Municipal Code of Chicago and the directions of the Commissioner of Department of Business Affairs and Consumer Protection, the Commissioner of Streets and Sanitation, and the Commissioner of Transportation.

The permit holder agrees to hold the City of Chicago harmless for any damage, relocation or replacement costs associated with damage, relocation or removal of private property caused by the City performing work in the public way.

Authority for the above named privilege is herein given and granted from and after March 1, 2014 through and including December 1, 2014.

Alderman 

Michele Smith 43rd Ward



City of Chicago



O2014-4594

Office of the City Clerk

Document Tracking Sheet

| | |
|---------------------------------|--|
| Meeting Date: | 5/28/2014 |
| Sponsor(s): | Smith (43) |
| Type: | Ordinance |
| Title: | Sidewalk cafe(s) for McGee's Tavern & Grille |
| Committee(s) Assignment: | Committee on Transportation and Public Way |

ORDINANCE
MCGEE'S TAVERN & GRILLE
Acct. No. 10789 - 1
Permit No. 1113063

Be It Ordained by the City Council of the City of Chicago:

Permission and authority are hereby given and granted to MCGEE'S TAVERN & GRILLE upon the terms and subject to the conditions of this ordinance, to maintain and use a portion of the public right of way for a sidewalk cafe adjacent to its premises located at 950 W. Webster Ave.. Said sidewalk cafe area #1 shall be sixty-six (66) feet in length and seven point eight (7.8) feet in width for a total of five hundred fourteen point eight (514.8) square feet and shall allow six (6) feet of clear space from the face of the curb/building line along W. Webster Avenue. The compensation for said space and the days and hours of operation for the sidewalk cafe shall be as follows:

Monday thru Friday 10:00 a.m. until 10:00 p.m. Saturday and Sunday 9:00am until 10:00pm
Compensation: \$600.00
SEATING CAPACITY: 40

Sidewalk Cafe Permit and approved plan must be posted at all times.

This grant of privilege #1113063 for a sidewalk cafe shall be subject to the provisions of Section 10-28-800 through 10-28-885 of the Municipal Code of Chicago and the directions of the Commissioner of Department of Business Affairs and Consumer Protection, the Commissioner of Streets and Sanitation, and the Commissioner of Transportation.

The permit holder agrees to hold the City of Chicago harmless for any damage, relocation or replacement costs associated with damage, relocation or removal of private property caused by the City performing work in the public way.

Authority for the above named privilege is herein given and granted from and after March 1, 2014 through and including December 1, 2014.

Alderman 

Michele Smith 43rd Ward



City of Chicago



O2014-4599

Office of the City Clerk

Document Tracking Sheet

| | |
|---------------------------------|--|
| Meeting Date: | 5/28/2014 |
| Sponsor(s): | Smith (43) |
| Type: | Ordinance |
| Title: | Sidewalk cafe(s) for Pizano's Pizza & Pasta On Lincoln |
| Committee(s) Assignment: | Committee on Transportation and Public Way |

ORDINANCE
PIZANO'S PIZZA & PASTA ON LINCOLN
Acct. No. 384523 - 1
Permit No. 1113161

Be It Ordained by the City Council of the City of Chicago:

Permission and authority are hereby given and granted to PIZANO'S PIZZA & PASTA ON LINCOLN upon the terms and subject to the conditions of this ordinance, to maintain and use a portion of the public right of way for a sidewalk cafe adjacent to its premises located at 2427-2429 N. Lincoln Ave.. Said sidewalk cafe area #1 shall be thirty point three three (30.33) feet in length and five (5) feet in width for a total of one hundred fifty-one point six five (151.65) square feet and shall allow six (6) feet of clear space from the face of the curb/building line along N. Lincoln Avenue. The compensation for said space and the days and hours of operation for the sidewalk cafe shall be as follows:

Monday through Sunday 11:00 a.m. to 12:00 midnight
Compensation: \$600.00
SEATING CAPACITY: 16

Sidewalk Cafe Permit and approved plan must be posted at all times.

This grant of privilege #1113161 for a sidewalk cafe shall be subject to the provisions of Section 10-28-800 through 10-28-885 of the Municipal Code of Chicago and the directions of the Commissioner of Department of Business Affairs and Consumer Protection, the Commissioner of Streets and Sanitation, and the Commissioner of Transportation.

The permit holder agrees to hold the City of Chicago harmless for any damage, relocation or replacement costs associated with damage, relocation or removal of private property caused by the City performing work in the public way.

Authority for the above named privilege is herein given and granted from and after March 1, 2014 through and including December 1, 2014.

Alderman 

Michele Smith 43rd Ward





City of Chicago



O2014-4604

Office of the City Clerk

Document Tracking Sheet

| | |
|---------------------------------|--|
| Meeting Date: | 5/28/2014 |
| Sponsor(s): | Smith (43) |
| Type: | Ordinance |
| Title: | Sidewalk cafe(s) for Woodie's Flat |
| Committee(s) Assignment: | Committee on Transportation and Public Way |

ORDINANCE
WOODIE'S FLAT
Acct. No. 9244 - 1
Permit No. 1113163

Be It Ordained by the City Council of the City of Chicago:

Permission and authority are hereby given and granted to WOODIE'S FLAT upon the terms and subject to the conditions of this ordinance, to maintain and use a portion of the public right of way for a sidewalk cafe adjacent to its premises located at 1535 N. Wells St.. Said sidewalk cafe area #1 shall be twenty-five (25) feet in length and nine (9) feet in width for a total of two hundred twenty-five (225) square feet and shall allow six (6) feet of clear space from the face of the curb/building line along N. Wells Street. The compensation for said space and the days and hours of operation for the sidewalk cafe shall be as follows:

Monday through Thursday 5:00 p.m. to 10:00 p.m. Friday 2:00 p.m. to 10:00 p.m.
Saturday and Sunday 11:00 a.m. to 10:00 p.m.
Compensation: \$600.00
SEATING CAPACITY: 28

Sidewalk Cafe Permit and approved plan must be posted at all times.

This grant of privilege #1113163 for a sidewalk cafe shall be subject to the provisions of Section 10-28-800 through 10-28-885 of the Municipal Code of Chicago and the directions of the Commissioner of Department of Business Affairs and Consumer Protection, the Commissioner of Streets and Sanitation, and the Commissioner of Transportation.

The permit holder agrees to hold the City of Chicago harmless for any damage, relocation or replacement costs associated with damage, relocation or removal of private property caused by the City performing work in the public way.

Authority for the above named privilege is herein given and granted from and after March 1, 2014 through and including December 1, 2014.

Alderman 

Michele Smith 43rd Ward



City of Chicago



O2014-4607

Office of the City Clerk

Document Tracking Sheet

| | |
|---------------------------------|--|
| Meeting Date: | 5/28/2014 |
| Sponsor(s): | Tunney (44) |
| Type: | Ordinance |
| Title: | Sidewalk cafe(s) for Beezzee |
| Committee(s) Assignment: | Committee on Transportation and Public Way |

ORDINANCE

Beezzee

Acct. No. 366728 - 1

Permit No. 1112916

Be It Ordained by the City Council of the City of Chicago:

Permission and authority are hereby given and granted to Beezzee upon the terms and subject to the conditions of this ordinance, to maintain and use a portion of the public right of way for a sidewalk cafe adjacent to its premises located at 2807 N. Sheffield Ave.. Said sidewalk cafe area #1 shall be twelve point one seven (12.17) feet in length and five (5) feet in width for a total of sixty point eight five (60.85) square feet and shall allow six (6) feet of clear space from the face of the curb/building line along N. Sheffield Avenue. The compensation for said space and the days and hours of operation for the sidewalk cafe shall be as follows:

Monday through Friday 11:00 a.m. to 10:00 p.m. Saturday and Sunday 10:00 a.m. to 10:00 p.m.

Compensation: \$600.00

SEATING CAPACITY: 12

Sidewalk Cafe Permit and approved plan must be posted at all times.

This grant of privilege #1112916 for a sidewalk cafe shall be subject to the provisions of Section 10-28-800 through 10-28-885 of the Municipal Code of Chicago and the directions of the Commissioner of Department of Business Affairs and Consumer Protection, the Commissioner of Streets and Sanitation, and the Commissioner of Transportation.

The permit holder agrees to hold the City of Chicago harmless for any damage, relocation or replacement costs associated with damage, relocation or removal of private property caused by the City performing work in the public way.

Authority for the above named privilege is herein given and granted from and after March 1, 2014 through and including December 1, 2014.

Alderman 
Thomas Tunney 44th Ward



City of Chicago



O2014-4612

Office of the City Clerk

Document Tracking Sheet

| | |
|---------------------------------|--|
| Meeting Date: | 5/28/2014 |
| Sponsor(s): | Tunney (44) |
| Type: | Ordinance |
| Title: | Sidewalk cafe(s) for Efes Restaurant |
| Committee(s) Assignment: | Committee on Transportation and Public Way |

ORDINANCE
EFES RESTAURANT
Acct. No. 368009 - 1
Permit No. 1112917

Be It Ordained by the City Council of the City of Chicago:

Permission and authority are hereby given and granted to EFES RESTAURANT upon the terms and subject to the conditions of this ordinance, to maintain and use a portion of the public right of way for a sidewalk cafe adjacent to its premises located at 2833 N. Broadway . Said sidewalk cafe area #1 shall be twenty-seven (27) feet in length and eight (8) feet in width for a total of two hundred sixteen (216) square feet and shall allow six (6) feet of clear space from the face of the curb/building line along Broadway. The compensation for said space and the days and hours of operation for the sidewalk cafe shall be as follows:

Sunday through Thursday 10:30 am to 10:00 pm Friday and Saturday 10:30 a.m. to 11:00 p.m.
Compensation: \$600.00
SEATING CAPACITY: 16

Sidewalk Cafe Permit and approved plan must be posted at all times.

This grant of privilege #1112917 for a sidewalk cafe shall be subject to the provisions of Section 10-28-800 through 10-28-885 of the Municipal Code of Chicago and the directions of the Commissioner of Department of Business Affairs and Consumer Protection, the Commissioner of Streets and Sanitation, and the Commissioner of Transportation.

The permit holder agrees to hold the City of Chicago harmless for any damage, relocation or replacement costs associated with damage, relocation or removal of private property caused by the City performing work in the public way.

Authority for the above named privilege is herein given and granted from and after March 1, 2014 through and including December 1, 2014.

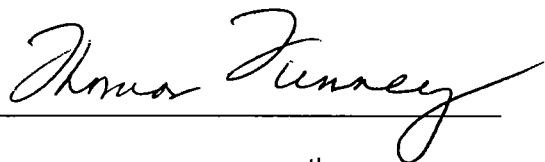
Alderman 
Thomas Tunney 44th Ward



City of Chicago



O2014-4617

Office of the City Clerk
Document Tracking Sheet

| | |
|---------------------------------|--|
| Meeting Date: | 5/28/2014 |
| Sponsor(s): | Tunney (44) |
| Type: | Ordinance |
| Title: | Sidewalk cafe(s) for Falafill |
| Committee(s) Assignment: | Committee on Transportation and Public Way |

ORDINANCE

Falafill

Acct. No. 346056 - 1

Permit No. 1112923

Be It Ordained by the City Council of the City of Chicago:

Permission and authority are hereby given and granted to Falafill upon the terms and subject to the conditions of this ordinance, to maintain and use a portion of the public right of way for a sidewalk cafe adjacent to its premises located at 3202 N. Broadway . Said sidewalk cafe area #1 shall be seventeen point five eight (17.58) feet in length and six point seven five (6.75) feet in width for a total of one hundred eighteen point six seven (118.67) square feet and shall allow six (6) feet of clear space from the face of the curb/building line along N. Broadway. The compensation for said space and the days and hours of operation for the sidewalk cafe shall be as follows:

Sunday through Saturday 11:00am until 10:00pm

Compensation: \$600.00

SEATING CAPACITY: 6

Sidewalk Cafe Permit and approved plan must be posted at all times.

This grant of privilege #1112923 for a sidewalk cafe shall be subject to the provisions of Section 10-28-800 through 10-28-885 of the Municipal Code of Chicago and the directions of the Commissioner of Department of Business Affairs and Consumer Protection, the Commissioner of Streets and Sanitation, and the Commissioner of Transportation.

The permit holder agrees to hold the City of Chicago harmless for any damage, relocation or replacement costs associated with damage, relocation or removal of private property caused by the City performing work in the public way.

Authority for the above named privilege is herein given and granted from and after March 1, 2014 through and including December 1, 2014.

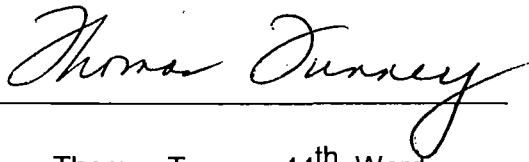
Alderman 
Thomas Tunney 44th Ward



City of Chicago



O2014-4621

Office of the City Clerk

Document Tracking Sheet

| | |
|---------------------------------|--|
| Meeting Date: | 5/28/2014 |
| Sponsor(s): | Tunney (44) |
| Type: | Ordinance |
| Title: | Sidewalk cafe(s) for Johnny O'Hagan's |
| Committee(s) Assignment: | Committee on Transportation and Public Way |

ORDINANCE
JOHNNY O'HAGAN'S
Acct. No. 383668 - 1
Permit No. 1113232

Be It Ordained by the City Council of the City of Chicago:

Permission and authority are hereby given and granted to JOHNNY O'HAGAN'S upon the terms and subject to the conditions of this ordinance, to maintain and use a portion of the public right of way for a sidewalk cafe adjacent to its premises located at 3374 N. Clark St.. Said sidewalk cafe area #1 shall be ninety point one seven (90.17) feet in length and five point three three (5.33) feet in width for a total of four hundred eighty point six one (480.61) square feet and shall allow six (6) feet of clear space from the face of the curb/building line along Roscoe Street. The compensation for said space and the days and hours of operation for the sidewalk cafe shall be as follows:

Monday through Thursday 11:00 a.m. to 10:00 p.m. Friday 11:00 am. to 11:00 p.m.
Saturday 9:00 a.m. to 11:00 p.m. Sunday 9:00 a.m. to 10:00 p.m.
Compensation: \$600.00
SEATING CAPACITY: 44

Sidewalk Cafe Permit and approved plan must be posted at all times.

This grant of privilege #1113232 for a sidewalk cafe shall be subject to the provisions of Section 10-28-800 through 10-28-885 of the Municipal Code of Chicago and the directions of the Commissioner of Department of Business Affairs and Consumer Protection, the Commissioner of Streets and Sanitation, and the Commissioner of Transportation.

The permit holder agrees to hold the City of Chicago harmless for any damage, relocation or replacement costs associated with damage, relocation or removal of private property caused by the City performing work in the public way.

Authority for the above named privilege is herein given and granted from and after March 1, 2014 through and including December 1, 2014.

Alderman Thomas Tunney
Thomas Tunney 44th Ward



City of Chicago



O2014-4673

Office of the City Clerk

Document Tracking Sheet

| | |
|---------------------------------|--|
| Meeting Date: | 5/28/2014 |
| Sponsor(s): | Tunney (44) |
| Type: | Ordinance |
| Title: | Sidewalk cafe(s) for Joys |
| Committee(s) Assignment: | Committee on Transportation and Public Way |

ORDINANCE
JOYS
Acct. No. 18118 - 2
Permit No. 1112925

Be It Ordained by the City Council of the City of Chicago:

Permission and authority are hereby given and granted to JOYS upon the terms and subject to the conditions of this ordinance, to maintain and use a portion of the public right of way for a sidewalk cafe adjacent to its premises located at 3257-59 N. Broadway . Said sidewalk cafe area #1 shall be thirty-seven point five (37.5) feet in length and seven (7) feet in width for a total of two hundred sixty-two point five (262.5) square feet and shall allow six (6) feet of clear space from the face of the curb/building line along N. Broadway. The compensation for said space and the days and hours of operation for the sidewalk cafe shall be as follows:

Sunday through Thursday 11:00 a.m. to 10:00 p.m. Friday and Saturday 11:00 a.m. to 11:00 p.m.
Compensation: \$600.00
SEATING CAPACITY: 20

Sidewalk Cafe Permit and approved plan must be posted at all times.

This grant of privilege #1112925 for a sidewalk cafe shall be subject to the provisions of Section 10-28-800 through 10-28-885 of the Municipal Code of Chicago and the directions of the Commissioner of Department of Business Affairs and Consumer Protection, the Commissioner of Streets and Sanitation, and the Commissioner of Transportation.

The permit holder agrees to hold the City of Chicago harmless for any damage, relocation or replacement costs associated with damage, relocation or removal of private property caused by the City performing work in the public way.

Authority for the above named privilege is herein given and granted from and after March 1, 2014 through and including December 1, 2014.

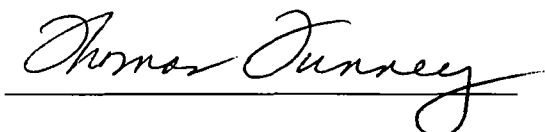
Alderman 
Thomas Tunney 44th Ward



City of Chicago

Office of the City Clerk

Document Tracking Sheet



O2014-4675

| | |
|---------------------------------|--|
| Meeting Date: | 5/28/2014 |
| Sponsor(s): | Tunney (44) |
| Type: | Ordinance |
| Title: | Sidewalk cafe(s) for MFK |
| Committee(s) Assignment: | Committee on Transportation and Public Way |

ORDINANCE

MFK

Acct. No. 20074 - 2

Permit No. 1113268

Be It Ordained by the City Council of the City of Chicago:

Permission and authority are hereby given and granted to MFK upon the terms and subject to the conditions of this ordinance, to maintain and use a portion of the public right of way for a sidewalk cafe adjacent to its premises located at 432 W. Diversey Pkwy.. Said sidewalk cafe area #1 shall be twenty-one point six seven (21.67) feet in length and six point six seven (6.67) feet in width for a total of one hundred forty-four point five four (144.54) square feet and shall allow six (6) feet of clear space from the face of the curb/building line along W. Diversey Parkway. The compensation for said space and the days and hours of operation for the sidewalk cafe shall be as follows:

Sunday through Thursday 8:00 a.m. to 10:00 p.m. Friday and Saturday 8:00 a.m. to 11:00 p.m.

Compensation: \$600.00

SEATING CAPACITY: 10

Sidewalk Cafe Permit and approved plan must be posted at all times.

This grant of privilege #1113268 for a sidewalk cafe shall be subject to the provisions of Section 10-28-800 through 10-28-885 of the Municipal Code of Chicago and the directions of the Commissioner of Department of Business Affairs and Consumer Protection, the Commissioner of Streets and Sanitation, and the Commissioner of Transportation.

The permit holder agrees to hold the City of Chicago harmless for any damage, relocation or replacement costs associated with damage, relocation or removal of private property caused by the City performing work in the public way.

Authority for the above named privilege is herein given and granted from and after March 1, 2014 through and including December 1, 2014.

Alderman



Thomas Tunney 44th Ward



City of Chicago



O2014-4676

Office of the City Clerk

Document Tracking Sheet

| | |
|---------------------------------|--|
| Meeting Date: | 5/28/2014 |
| Sponsor(s): | Tunney (44) |
| Type: | Ordinance |
| Title: | Sidewalk cafe(s) for Michael Diversey's |
| Committee(s) Assignment: | Committee on Transportation and Public Way |

ORDINANCE
MICHAEL DIVERSEY'S
Acct. No. 337437 - 1
Permit No. 1113251

Be It Ordained by the City Council of the City of Chicago:

Permission and authority are hereby given and granted to MICHAEL DIVERSEY'S upon the terms and subject to the conditions of this ordinance, to maintain and use a portion of the public right of way for a sidewalk cafe adjacent to its premises located at 670 W. Diversey Pkwy.. Said sidewalk cafe area #1 shall be thirty-two point six seven (32.67) feet in length and five point three three (5.33) feet in width for a total of one hundred seventy-four point one three (174.13) square feet and shall allow six (6) feet of clear space from the face of the curb/building line along W. Diversey Parkway. The compensation for said space and the days and hours of operation for the sidewalk cafe shall be as follows:

Sunday through Thursday 9:00 a.m. to 10:00 p.m. Friday and Saturday 9:00 a.m. to 11:00 p.m.
Compensation: \$600.00
SEATING CAPACITY: 16

Sidewalk Cafe Permit and approved plan must be posted at all times.

This grant of privilege #1113251 for a sidewalk cafe shall be subject to the provisions of Section 10-28-800 through 10-28-885 of the Municipal Code of Chicago and the directions of the Commissioner of Department of Business Affairs and Consumer Protection, the Commissioner of Streets and Sanitation, and the Commissioner of Transportation.

The permit holder agrees to hold the City of Chicago harmless for any damage, relocation or replacement costs associated with damage, relocation or removal of private property caused by the City performing work in the public way.

Authority for the above named privilege is herein given and granted from and after March 1, 2014 through and including December 1, 2014.

Alderman 
Thomas Tunney 44th Ward





City of Chicago



O2014-4678

Office of the City Clerk

Document Tracking Sheet

| | |
|---------------------------------|---|
| Meeting Date: | 5/28/2014 |
| Sponsor(s): | Tunney (44) |
| Type: | Ordinance |
| Title: | Sidewalk cafe(s) for Omalley's Liquor Kitchen |
| Committee(s) Assignment: | Committee on Transportation and Public Way |

ORDINANCE
OMALLEY'S LIQUOR KITCHEN
Acct. No. 8109 - 1
Permit No. 1113128

Be It Ordained by the City Council of the City of Chicago:

Permission and authority are hereby given and granted to OMALLEY'S LIQUOR KITCHEN upon the terms and subject to the conditions of this ordinance, to maintain and use a portion of the public right of way for a sidewalk cafe adjacent to its premises located at 3551 N. Sheffield Ave.. Said sidewalk cafe area #1 shall be nineteen point seven five (19.75) feet in length and eight point two five (8.25) feet in width, area #2 shall be twenty point two five (20.25) feet in length and eight point two five (8.25) feet in width for a total of three hundred thirty (330) square feet and shall allow six (6) feet of clear space from the face of the curb/building line along N. Sheffield Avenue. The compensation for said space and the days and hours of operation for the sidewalk cafe shall be as follows:

Sunday through Thursday 10:00 a.m. to 10:00 p.m. Friday through Saturday 10:00 a.m. to 11:00 p.m.
Compensation: \$600.00
SEATING CAPACITY: 32

Sidewalk Cafe Permit and approved plan must be posted at all times.

This grant of privilege #1113128 for a sidewalk cafe shall be subject to the provisions of Section 10-28-800 through 10-28-885 of the Municipal Code of Chicago and the directions of the Commissioner of Department of Business Affairs and Consumer Protection, the Commissioner of Streets and Sanitation, and the Commissioner of Transportation.

The permit holder agrees to hold the City of Chicago harmless for any damage, relocation or replacement costs associated with damage, relocation or removal of private property caused by the City performing work in the public way.

Authority for the above named privilege is herein given and granted from and after March 1, 2014 through and including December 1, 2014.

Alderman Thomas Tunney

Thomas Tunney 44th Ward



City of Chicago



O2014-4682

Office of the City Clerk

Document Tracking Sheet

| | |
|---------------------------------|--|
| Meeting Date: | 5/28/2014 |
| Sponsor(s): | Tunney (44) |
| Type: | Ordinance |
| Title: | Sidewalk cafe(s) for Ping Pong |
| Committee(s) Assignment: | Committee on Transportation and Public Way |

ORDINANCE
PING PONG
Acct. No. 259039 - 2
Permit No. 1113246

Be It Ordained by the City Council of the City of Chicago:

Permission and authority are hereby given and granted to PING PONG upon the terms and subject to the conditions of this ordinance, to maintain and use a portion of the public right of way for a sidewalk cafe adjacent to its premises located at 3322-3326 N. Broadway . Said sidewalk cafe area #1 shall be forty-four (44) feet in length and seven (7) feet in width for a total of three hundred eight (308) square feet and shall allow six (6) feet of clear space from the face of the curb/building line along N. Broadway. The compensation for said space and the days and hours of operation for the sidewalk cafe shall be as follows:

Sunday Noon - 10:00 pm Monday through Thursday 4:00pm - 10:00pm Friday 4:00pm - 11:00pm Saturday Noon - 11:00 pm
Compensation: \$600.00
SEATING CAPACITY: 32

Sidewalk Cafe Permit and approved plan must be posted at all times.

This grant of privilege #1113246 for a sidewalk cafe shall be subject to the provisions of Section 10-28-800 through 10-28-885 of the Municipal Code of Chicago and the directions of the Commissioner of Department of Business Affairs and Consumer Protection, the Commissioner of Streets and Sanitation, and the Commissioner of Transportation.

The permit holder agrees to hold the City of Chicago harmless for any damage, relocation or replacement costs associated with damage, relocation or removal of private property caused by the City performing work in the public way.

Authority for the above named privilege is herein given and granted from and after March 1, 2014 through and including December 1, 2014.

Alderman Thomas Tunney
Thomas Tunney 44th Ward



City of Chicago

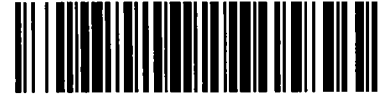

O2014-4684

Office of the City Clerk

Document Tracking Sheet

| | |
|---------------------------------|--|
| Meeting Date: | 5/28/2014 |
| Sponsor(s): | Tunney (44) |
| Type: | Ordinance |
| Title: | Sidewalk cafe(s) for Redmond's |
| Committee(s) Assignment: | Committee on Transportation and Public Way |

ORDINANCE
REDMOND'S
Acct. No. 7460 - 1
Permit No. 1113241

Be It Ordained by the City Council of the City of Chicago:

Permission and authority are hereby given and granted to REDMOND'S upon the terms and subject to the conditions of this ordinance, to maintain and use a portion of the public right of way for a sidewalk cafe adjacent to its premises located at 3358 N. Sheffield Ave.. Said sidewalk cafe area #1 shall be sixty-eight point six (68.6) feet in length and ten (10) feet in width for a total of six hundred eighty-six (686) square feet and shall allow six (6) feet of clear space from the face of the curb/building line along W. Roscoe Street. The compensation for said space and the days and hours of operation for the sidewalk cafe shall be as follows:

Sunday through Thursday 10:00 a.m. to 10:00 p.m. Friday and Saturday 10:00 a.m. to 11:00 p.m.

Compensation: \$754.60

SEATING CAPACITY: 72

Sidewalk Cafe Permit and approved plan must be posted at all times.

This grant of privilege #1113241 for a sidewalk cafe shall be subject to the provisions of Section 10-28-800 through 10-28-885 of the Municipal Code of Chicago and the directions of the Commissioner of Department of Business Affairs and Consumer Protection, the Commissioner of Streets and Sanitation, and the Commissioner of Transportation.

The permit holder agrees to hold the City of Chicago harmless for any damage, relocation or replacement costs associated with damage, relocation or removal of private property caused by the City performing work in the public way.

Authority for the above named privilege is herein given and granted from and after March 1, 2014 through and including December 1, 2014.

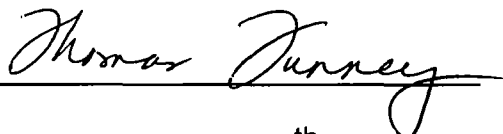
Alderman 
Thomas Tunney 44th Ward



City of Chicago



O2014-4685

Office of the City Clerk

Document Tracking Sheet

| | |
|---------------------------------|---|
| Meeting Date: | 5/28/2014 |
| Sponsor(s): | Tunney (44) |
| Type: | Ordinance |
| Title: | Sidewalk cafe(s) for Spencer's Jolly Posh Foods |
| Committee(s) Assignment: | Committee on Transportation and Public Way |

ORDINANCE
SPENCER'S JOLLY POSH FOODS
Acct. No. 387134 - 1
Permit No. 1111179

Be It Ordained by the City Council of the City of Chicago:

Permission and authority are hereby given and granted to SPENCER'S JOLLY POSH FOODS upon the terms and subject to the conditions of this ordinance, to maintain and use a portion of the public right of way for a sidewalk cafe adjacent to its premises located at 3755 N. Southport Ave.. Said sidewalk cafe area #1 shall be twenty-two (22) feet in length and ten (10) feet in width for a total of two hundred twenty (220) square feet and shall allow six (6) feet of clear space from the face of the curb/building line along N. Southport Avenue. The compensation for said space and the days and hours of operation for the sidewalk cafe shall be as follows:

Sunday through Thursday 8:00 a.m. to 10:00 p.m. Friday and Saturday 8:00 a.m. to 11:00 p.m.
Compensation: \$600.00
SEATING CAPACITY: 18

Sidewalk Cafe Permit and approved plan must be posted at all times.

This grant of privilege #1111179 for a sidewalk cafe shall be subject to the provisions of Section 10-28-800 through 10-28-885 of the Municipal Code of Chicago and the directions of the Commissioner of Department of Business Affairs and Consumer Protection, the Commissioner of Streets and Sanitation, and the Commissioner of Transportation.

The permit holder agrees to hold the City of Chicago harmless for any damage, relocation or replacement costs associated with damage, relocation or removal of private property caused by the City performing work in the public way.

Authority for the above named privilege is herein given and granted from and after March 1, 2014 through and including December 1, 2014.

Alderman Thomas Tunney
Thomas Tunney 44th Ward



City of Chicago



O2014-4688

Office of the City Clerk

Document Tracking Sheet

| | |
|---------------------------------|--|
| Meeting Date: | 5/28/2014 |
| Sponsor(s): | Tunney (44) |
| Type: | Ordinance |
| Title: | Sidewalk cafe(s) for Tac Quick |
| Committee(s) Assignment: | Committee on Transportation and Public Way |

ORDINANCE
TAC QUICK
Acct. No. 209093 - 2
Permit No. 1113141

Be It Ordained by the City Council of the City of Chicago:

Permission and authority are hereby given and granted to TAC QUICK upon the terms and subject to the conditions of this ordinance, to maintain and use a portion of the public right of way for a sidewalk cafe adjacent to its premises located at 3928-3930 N. Sheridan Rd.. Said sidewalk cafe area #1 shall be forty-one point five (41.5) feet in length and nine point eight three (9.83) feet in width for a total of four hundred seven point nine five (407.95) square feet and shall allow six (6) feet of clear space from the face of the curb/building line along N. Sheridan. The compensation for said space and the days and hours of operation for the sidewalk cafe shall be as follows:

Sunday through Thursday 11:00 a.m. until 11:00 p.m. Friday & Saturday 11:00am until 11:45pm Closed on Tuesday
Compensation: \$600.00
SEATING CAPACITY: 23

Sidewalk Cafe Permit and approved plan must be posted at all times.

This grant of privilege #1113141 for a sidewalk cafe shall be subject to the provisions of Section 10-28-800 through 10-28-885 of the Municipal Code of Chicago and the directions of the Commissioner of Department of Business Affairs and Consumer Protection, the Commissioner of Streets and Sanitation, and the Commissioner of Transportation.

The permit holder agrees to hold the City of Chicago harmless for any damage, relocation or replacement costs associated with damage, relocation or removal of private property caused by the City performing work in the public way.

Authority for the above named privilege is herein given and granted from and after March 1, 2014 through and including December 1, 2014.

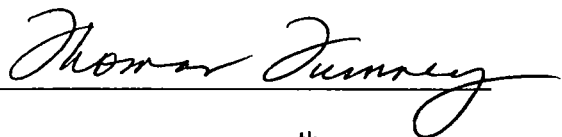
Alderman 
Thomas Tunney 44th Ward



City of Chicago



O2014-4689

Office of the City Clerk

Document Tracking Sheet

| | |
|---------------------------------|--|
| Meeting Date: | 5/28/2014 |
| Sponsor(s): | Tunney (44) |
| Type: | Ordinance |
| Title: | Sidewalk cafe(s) for Wakamono |
| Committee(s) Assignment: | Committee on Transportation and Public Way |

ORDINANCE
WAKAMONO
Acct. No. 257616 - 2
Permit No. 1113245

Be It Ordained by the City Council of the City of Chicago:

Permission and authority are hereby given and granted to WAKAMONO upon the terms and subject to the conditions of this ordinance, to maintain and use a portion of the public right of way for a sidewalk cafe adjacent to its premises located at 3313-17 N. Broadway . Said sidewalk cafe area #1 shall be forty-five point five (45.5) feet in length and seven (7) feet in width for a total of three hundred eighteen point five (318.5) square feet and shall allow six (6) feet of clear space from the face of the curb/building line along N. Broadway. The compensation for said space and the days and hours of operation for the sidewalk cafe shall be as follows:

Sunday Noon - 10:00 pm Monday to Thursday 4:00 p.m.-10:00 p.m. Friday 4:00pm-11:00pm Saturday 4:00 pm - 11:00 pm
Compensation: \$600.00
SEATING CAPACITY: 32

Sidewalk Cafe Permit and approved plan must be posted at all times.

This grant of privilege #1113245 for a sidewalk cafe shall be subject to the provisions of Section 10-28-800 through 10-28-885 of the Municipal Code of Chicago and the directions of the Commissioner of Department of Business Affairs and Consumer Protection, the Commissioner of Streets and Sanitation, and the Commissioner of Transportation.

The permit holder agrees to hold the City of Chicago harmless for any damage, relocation or replacement costs associated with damage, relocation or removal of private property caused by the City performing work in the public way.

Authority for the above named privilege is herein given and granted from and after March 1, 2014 through and including December 1, 2014.

Alderman 
Thomas Tunney 44th Ward



City of Chicago



O2014-4691

Office of the City Clerk

Document Tracking Sheet

| | |
|---------------------------------|--|
| Meeting Date: | 5/28/2014 |
| Sponsor(s): | Arena (45) |
| Type: | Ordinance |
| Title: | Sidewalk cafe(s) for Margaret's |
| Committee(s) Assignment: | Committee on Transportation and Public Way |

ORDINANCE
MARGARET'S
Acct. No. 340208 - 1
Permit No. 1113142

Be It Ordained by the City Council of the City of Chicago:

Permission and authority are hereby given and granted to MARGARET'S upon the terms and subject to the conditions of this ordinance, to maintain and use a portion of the public right of way for a sidewalk cafe adjacent to its premises located at 5134 W. Irving Park Rd.. Said sidewalk cafe area #1 shall be twenty (20) feet in length and ten (10) feet in width for a total of two hundred (200) square feet and shall allow six (6) feet of clear space from the face of the curb/building line along W. Irving Park Road. The compensation for said space and the days and hours of operation for the sidewalk cafe shall be as follows:

Monday through Saturday 3:00 p.m. to 12:00 midnight Sunday 12:00 p.m. to 12:00 midnight
Compensation: \$600.00
SEATING CAPACITY: 12

Sidewalk Cafe Permit and approved plan must be posted at all times.

This grant of privilege #1113142 for a sidewalk cafe shall be subject to the provisions of Section 10-28-800 through 10-28-885 of the Municipal Code of Chicago and the directions of the Commissioner of Department of Business Affairs and Consumer Protection, the Commissioner of Streets and Sanitation, and the Commissioner of Transportation.

The permit holder agrees to hold the City of Chicago harmless for any damage, relocation or replacement costs associated with damage, relocation or removal of private property caused by the City performing work in the public way.

Authority for the above named privilege is herein given and granted from and after March 1, 2014 through and including December 1, 2014.

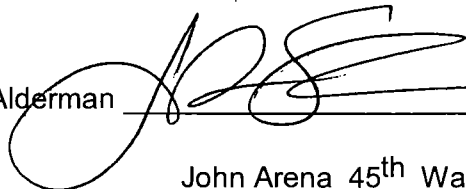
Alderman 
John Arena 45th Ward



05/28/2014

Alderman **John Arena**
Ward # **45**
City of Chicago
City Hall, Room **305**
121 North LaSalle Street
Chicago, Illinois 60602

Re: An ordinance to use and maintain a portion of the public right-of-way for **one (1) sidewalk cafe(s)** for **MARGARET'S**, adjacent to the premises known as **5134 W. Irving Park Rd.**.

Dear Alderman **John Arena**:

The applicant referenced above has requested the use of the public right-of-way for a **sidewalk cafe(s)**. An ordinance has been prepared by the Department of Business Affairs and Consumer Protection – Small Business Center - Public Way Use Unit for presentation to the City Council. Because this request was made for properties located in your ward, as approved by you as per the attached, I respectfully request that you introduce the attached ordinance at the next City Council meeting.

If you have any questions regarding this ordinance, please contact Anthony Bertuca at (312) 744-5506.

Department of Business Affairs and Consumer Protection



City of Chicago



O2014-4694

Office of the City Clerk

Document Tracking Sheet

| | |
|---------------------------------|--|
| Meeting Date: | 5/28/2014 |
| Sponsor(s): | Arena (45) |
| Type: | Ordinance |
| Title: | Sidewalk cafe(s) for Rasmus |
| Committee(s) Assignment: | Committee on Transportation and Public Way |

ORDINANCE
RASMOS
Acct. No. 206660 - 1
Permit No. 1113129

Be It Ordained by the City Council of the City of Chicago:

Permission and authority are hereby given and granted to RASMOS upon the terms and subject to the conditions of this ordinance, to maintain and use a portion of the public right of way for a sidewalk cafe adjacent to its premises located at 4788 N. Elston Ave.. Said sidewalk cafe area #1 shall be thirty (30) feet in length and fifteen (15) feet in width, area #2 shall be twenty-nine (29) feet in length and ten (10) feet in width for a total of seven hundred forty (740) square feet and shall allow six (6) feet of clear space from the face of the curb/building line along N. Kenneth Avenue, N. Kenneth Avenue. The compensation for said space and the days and hours of operation for the sidewalk cafe shall be as follows:

Monday thru Saturday 10:00 a.m. TO 10:00 p.m. Sunday 11:00 a.m. TO 10:00 p.m.
Compensation: \$814.00
SEATING CAPACITY: 32

Sidewalk Cafe Permit and approved plan must be posted at all times.

This grant of privilege #1113129 for a sidewalk cafe shall be subject to the provisions of Section 10-28-800 through 10-28-885 of the Municipal Code of Chicago and the directions of the Commissioner of Department of Business Affairs and Consumer Protection, the Commissioner of Streets and Sanitation, and the Commissioner of Transportation.

The permit holder agrees to hold the City of Chicago harmless for any damage, relocation or replacement costs associated with damage, relocation or removal of private property caused by the City performing work in the public way.

Authority for the above named privilege is herein given and granted from and after March 1, 2014 through and including December 1, 2014.

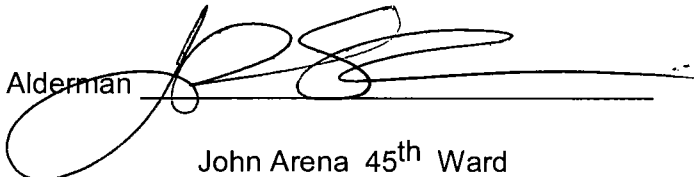
Alderman 
John Arena 45th Ward



City of Chicago



O2014-4696

Office of the City Clerk

Document Tracking Sheet

| | |
|---------------------------------|--|
| Meeting Date: | 5/28/2014 |
| Sponsor(s): | Cappleman (46) |
| Type: | Ordinance |
| Title: | Sidewalk cafe(s) for Baker & Nosh Bakery |
| Committee(s) Assignment: | Committee on Transportation and Public Way |

ORDINANCE
BAKER & NOSH BAKERY
Acct. No. 367009 - 2
Permit No. 1113133

Be It Ordained by the City Council of the City of Chicago:

Permission and authority are hereby given and granted to BAKER & NOSH BAKERY upon the terms and subject to the conditions of this ordinance, to maintain and use a portion of the public right of way for a sidewalk cafe adjacent to its premises located at 1303-1309 W. Wilson Ave.. Said sidewalk cafe area #1 shall be thirty-six point two five (36.25) feet in length and twelve point zero eight (12.08) feet in width for a total of four hundred thirty-seven point nine (437.9) square feet and shall allow six (6) feet of clear space from the face of the curb/building line along W. Wilson Avenue. The compensation for said space and the days and hours of operation for the sidewalk cafe shall be as follows:

Monday through Friday 8:00 am to 10:00 pm Saturday 8:00 a.m. to 5:00 p.m. Sunday
8:00 a.m. to 3:00 p.m.
Compensation: \$600.00
SEATING CAPACITY: 32

Sidewalk Cafe Permit and approved plan must be posted at all times.

This grant of privilege #1113133 for a sidewalk cafe shall be subject to the provisions of Section 10-28-800 through 10-28-885 of the Municipal Code of Chicago and the directions of the Commissioner of Department of Business Affairs and Consumer Protection, the Commissioner of Streets and Sanitation, and the Commissioner of Transportation.

The permit holder agrees to hold the City of Chicago harmless for any damage, relocation or replacement costs associated with damage, relocation or removal of private property caused by the City performing work in the public way.

Authority for the above named privilege is herein given and granted from and after March 1, 2014 through and including December 1, 2014.

Alderman _____



James Cappleman 46th Ward



05/28/2014

Alderman **James Cappleman**
Ward # **46**
City of Chicago
City Hall, Room **300**
121 North LaSalle Street
Chicago, Illinois 60602

Re: An ordinance to use and maintain a portion of the public right-of-way for **one (1) sidewalk cafe(s)** for **BAKER & NOSH BAKERY**, adjacent to the premises known as **1303-1309 W. Wilson Ave.**

Dear Alderman **James Cappleman**:

The applicant referenced above has requested the use of the public right-of-way for a **sidewalk cafe(s)**. An ordinance has been prepared by the Department of Business Affairs and Consumer Protection – Small Business Center - Public Way Use Unit for presentation to the City Council. Because this request was made for properties located in your ward, as approved by you as per the attached, I respectfully request that you introduce the attached ordinance at the next City Council meeting.

If you have any questions regarding this ordinance, please contact Anthony Bertuca at (312) 744-5506.

Department of Business Affairs and Consumer Protection



City of Chicago



O2014-4697

Office of the City Clerk

Document Tracking Sheet

| | |
|---------------------------------|--|
| Meeting Date: | 5/28/2014 |
| Sponsor(s): | Cappleman (46) |
| Type: | Ordinance |
| Title: | Sidewalk cafe(s) for Coronas Coffee II |
| Committee(s) Assignment: | Committee on Transportation and Public Way |

ORDINANCE
CORONAS COFFEE II
Acct. No. 308607 - 1
Permit No. 1113053

Be It Ordained by the City Council of the City of Chicago:

Permission and authority are hereby given and granted to CORONAS COFFEE II upon the terms and subject to the conditions of this ordinance, to maintain and use a portion of the public right of way for a sidewalk cafe adjacent to its premises located at 909 W. Irving Park Rd.. Said sidewalk cafe area #1 shall be seventeen point eight three (17.83) feet in length and six point four two (6.42) feet in width for a total of one hundred fourteen point four seven (114.47) square feet and shall allow six (6) feet of clear space from the face of the curb/building line along W. Irving Park Road. The compensation for said space and the days and hours of operation for the sidewalk cafe shall be as follows:

Monday through Friday 8:00 a.m. to 7:00 p.m. Saturday 8:00 a.m. to 6:00 p.m. Sunday
8:00 a.m. to 5:00 p.m.
Compensation: \$600.00
SEATING CAPACITY: 9

Sidewalk Cafe Permit and approved plan must be posted at all times.

This grant of privilege #1113053 for a sidewalk cafe shall be subject to the provisions of Section 10-28-800 through 10-28-885 of the Municipal Code of Chicago and the directions of the Commissioner of Department of Business Affairs and Consumer Protection, the Commissioner of Streets and Sanitation, and the Commissioner of Transportation.

The permit holder agrees to hold the City of Chicago harmless for any damage, relocation or replacement costs associated with damage, relocation or removal of private property caused by the City performing work in the public way.

Authority for the above named privilege is herein given and granted from and after March 1, 2014 through and including December 1, 2014.

Alderman _____



James Cappleman 46th Ward



05/28/2014

Alderman **James Cappleman**
Ward # **46**
City of Chicago
City Hall, Room **300**
121 North LaSalle Street
Chicago, Illinois 60602

Re: An ordinance to use and maintain a portion of the public right-of-way for **one (1) sidewalk cafe(s)** for **CORONAS COFFEE II**, adjacent to the premises known as **909 W. Irving Park Rd.**

Dear Alderman **James Cappleman**:

The applicant referenced above has requested the use of the public right-of-way for a **sidewalk cafe(s)**. An ordinance has been prepared by the Department of Business Affairs and Consumer Protection – Small Business Center - Public Way Use Unit for presentation to the City Council. Because this request was made for properties located in your ward, as approved by you as per the attached, I respectfully request that you introduce the attached ordinance at the next City Council meeting.

If you have any questions regarding this ordinance, please contact Anthony Bertuca at (312) 744-5506.

Department of Business Affairs and Consumer Protection



City of Chicago



O2014-4700

Office of the City Clerk

Document Tracking Sheet

| | |
|---------------------------------|--|
| Meeting Date: | 5/28/2014 |
| Sponsor(s): | Cappleman (46) |
| Type: | Ordinance |
| Title: | Sidewalk cafe(s) for Taverna 750 |
| Committee(s) Assignment: | Committee on Transportation and Public Way |

ORDINANCE
TAVERNA 750
Acct. No. 86187 - 3
Permit No. 1113130

Be It Ordained by the City Council of the City of Chicago:

Permission and authority are hereby given and granted to TAVERNA 750 upon the terms and subject to the conditions of this ordinance, to maintain and use a portion of the public right of way for a sidewalk cafe adjacent to its premises located at 750 W. Cornelia Ave.. Said sidewalk cafe area #1 shall be forty-four point four two (44.42) feet in length and seven point four two (7.42) feet in width for a total of three hundred twenty-nine point six (329.6) square feet and shall allow six (6) feet of clear space from the face of the curb/building line along W. Cornelia Avenue. The compensation for said space and the days and hours of operation for the sidewalk cafe shall be as follows:

Monday through Friday 5:30 p.m. to 12:00 Midnight Saturday and Sunday 10:00 a.m. to 12:00 Midnight
Compensation: \$600.00
SEATING CAPACITY: 44

Sidewalk Cafe Permit and approved plan must be posted at all times.

This grant of privilege #1113130 for a sidewalk cafe shall be subject to the provisions of Section 10-28-800 through 10-28-885 of the Municipal Code of Chicago and the directions of the Commissioner of Department of Business Affairs and Consumer Protection, the Commissioner of Streets and Sanitation, and the Commissioner of Transportation.

The permit holder agrees to hold the City of Chicago harmless for any damage, relocation or replacement costs associated with damage, relocation or removal of private property caused by the City performing work in the public way.

Authority for the above named privilege is herein given and granted from and after March 1, 2014 through and including December 1, 2014.

Alderman



James Cappleman 46th Ward



05/28/2014

Alderman **James Cappleman**
Ward # **46**
City of Chicago
City Hall, Room **300**
121 North LaSalle Street
Chicago, Illinois 60602

Re: An ordinance to use and maintain a portion of the public right-of-way for **one (1) sidewalk cafe(s)** for **TAVERNA 750**, adjacent to the premises known as **750 W. Cornelia Ave.**.

Dear Alderman **James Cappleman**:

The applicant referenced above has requested the use of the public right-of-way for a **sidewalk cafe(s)**. An ordinance has been prepared by the Department of Business Affairs and Consumer Protection – Small Business Center - Public Way Use Unit for presentation to the City Council. Because this request was made for properties located in your ward, as approved by you as per the attached, I respectfully request that you introduce the attached ordinance at the next City Council meeting.

If you have any questions regarding this ordinance, please contact Anthony Bertuca at (312) 744-5506.

Department of Business Affairs and Consumer Protection



City of Chicago



O2014-4348

Office of the City Clerk

Document Tracking Sheet

| | |
|---------------------------------|--|
| Meeting Date: | 5/28/2014 |
| Sponsor(s): | Pawar (47) |
| Type: | Ordinance |
| Title: | Sidewalk cafe(s) for Revolver |
| Committee(s) Assignment: | Committee on Transportation and Public Way |

ORDINANCE
REVOLVER
Acct. No. 86582 - 2
Permit No. 1113138

Be It Ordained by the City Council of the City of Chicago:

Permission and authority are hereby given and granted to REVOLVER upon the terms and subject to the conditions of this ordinance, to maintain and use a portion of the public right of way for a sidewalk cafe adjacent to its premises located at 3759 N. Damen Ave.. Said sidewalk cafe area #1 shall be sixty-eight (68) feet in length and nine point two five (9.25) feet in width for a total of six hundred twenty-nine (629) square feet and shall allow six (6) feet of clear space from the face of the curb/building line along W. Grace Street. The compensation for said space and the days and hours of operation for the sidewalk cafe shall be as follows:

Monday through Friday 12:00 noon to 12:00 midnight Saturday and Sunday 10:00 a.m.
to 12:00 midnight
Compensation: \$691.90
SEATING CAPACITY: 34

Sidewalk Cafe Permit and approved plan must be posted at all times.

This grant of privilege #1113138 for a sidewalk cafe shall be subject to the provisions of Section 10-28-800 through 10-28-885 of the Municipal Code of Chicago and the directions of the Commissioner of Department of Business Affairs and Consumer Protection, the Commissioner of Streets and Sanitation, and the Commissioner of Transportation.

The permit holder agrees to hold the City of Chicago harmless for any damage, relocation or replacement costs associated with damage, relocation or removal of private property caused by the City performing work in the public way.

Authority for the above named privilege is herein given and granted from and after March 1, 2014 through and including December 1, 2014.

Alderman



Ameya Pawar 47th Ward

3



05/28/2014

Alderman **Ameya Pawar**
Ward # 47
City of Chicago
City Hall, Room 300
121 North LaSalle Street
Chicago, Illinois 60602

Re: An ordinance to use and maintain a portion of the public right-of-way for **one (1) sidewalk cafe(s)** for **REVOLVER**, adjacent to the premises known as **3759 N. Damen Ave.**.

Dear Alderman **Ameya Pawar**:

The applicant referenced above has requested the use of the public right-of-way for a **sidewalk cafe(s)**. An ordinance has been prepared by the Department of Business Affairs and Consumer Protection – Small Business Center - Public Way Use Unit for presentation to the City Council. Because this request was made for properties located in your ward, as approved by you as per the attached, I respectfully request that you introduce the attached ordinance at the next City Council meeting.

If you have any questions regarding this ordinance, please contact Anthony Bertuca at (312) 744-5506.

Department of Business Affairs and Consumer Protection



City of Chicago



O2014-4701

Office of the City Clerk

Document Tracking Sheet

| | |
|---------------------------------|--|
| Meeting Date: | 5/28/2014 |
| Sponsor(s): | Osterman (48) |
| Type: | Ordinance |
| Title: | Sidewalk cafe(s) for Chicago Grind |
| Committee(s) Assignment: | Committee on Transportation and Public Way |

ORDINANCE
CHICAGO GRIND
Acct. No. 390293 - 1
Permit No. 1113294

Be It Ordained by the City Council of the City of Chicago:

Permission and authority are hereby given and granted to CHICAGO GRIND upon the terms and subject to the conditions of this ordinance, to maintain and use a portion of the public right of way for a sidewalk cafe adjacent to its premises located at 5256 N. Broadway . Said sidewalk cafe area #1 shall be forty (40) feet in length and ten (10) feet in width for a total of four hundred (400) square feet and shall allow six (6) feet of clear space from the face of the curb/building line along W. Berwyn. The compensation for said space and the days and hours of operation for the sidewalk cafe shall be as follows:

Monday through Sunday 8:00 a.m. to 9:00 p.m.
Compensation: \$600.00
SEATING CAPACITY: 18

Sidewalk Cafe Permit and approved plan must be posted at all times.

This grant of privilege #1113294 for a sidewalk cafe shall be subject to the provisions of Section 10-28-800 through 10-28-885 of the Municipal Code of Chicago and the directions of the Commissioner of Department of Business Affairs and Consumer Protection, the Commissioner of Streets and Sanitation, and the Commissioner of Transportation.

The permit holder agrees to hold the City of Chicago harmless for any damage, relocation or replacement costs associated with damage, relocation or removal of private property caused by the City performing work in the public way.

Authority for the above named privilege is herein given and granted from and after March 1, 2014 through and including December 1, 2014.

Alderman _____

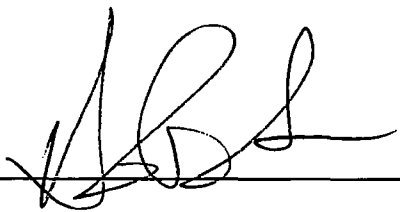

Harry Osterman 48th Ward



05/28/2014

Alderman **Harry Osterman**
Ward # **48**
City of Chicago
City Hall, Room **300**
121 North LaSalle Street
Chicago, Illinois 60602

Re: An ordinance to use and maintain a portion of the public right-of-way for **one (1) sidewalk cafe(s)** for **CHICAGO GRIND**, adjacent to the premises known as **5256 N. Broadway**.

Dear Alderman **Harry Osterman**:

The applicant referenced above has requested the use of the public right-of-way for a **sidewalk cafe(s)**. An ordinance has been prepared by the Department of Business Affairs and Consumer Protection – Small Business Center - Public Way Use Unit for presentation to the City Council. Because this request was made for properties located in your ward, as approved by you as per the attached, I respectfully request that you introduce the attached ordinance at the next City Council meeting.

If you have any questions regarding this ordinance, please contact Anthony Bertuca at (312) 744-5506.

Department of Business Affairs and Consumer Protection



City of Chicago



O2014-4703

Office of the City Clerk

Document Tracking Sheet

| | |
|---------------------------------|--|
| Meeting Date: | 5/28/2014 |
| Sponsor(s): | Osterman (48) |
| Type: | Ordinance |
| Title: | Sidewalk cafe(s) for Demera Ethiopian Restaurant |
| Committee(s) Assignment: | Committee on Transportation and Public Way |

ORDINANCE
DEMERA ETHIOPIAN RESTAURANT
Acct. No. 319202 - 1
Permit No. 1112915

Be It Ordained by the City Council of the City of Chicago:

Permission and authority are hereby given and granted to DEMERA ETHIOPIAN RESTAURANT upon the terms and subject to the conditions of this ordinance, to maintain and use a portion of the public right of way for a sidewalk cafe adjacent to its premises located at 4801 N. Broadway . Said sidewalk cafe area #1 shall be forty-three point five (43.5) feet in length and thirteen point one seven (13.17) feet in width for a total of five hundred seventy-two point nine (572.9) square feet and shall allow six (6) feet of clear space from the face of the curb/building line along N. Broadway. The compensation for said space and the days and hours of operation for the sidewalk cafe shall be as follows:

Sunday through Thursday 11:30am to 11:00 p.m. Friday and Saturday 11:30am to 12:00 a.m.
Compensation: \$630.18
SEATING CAPACITY: 35

Sidewalk Cafe Permit and approved plan must be posted at all times.

This grant of privilege #1112915 for a sidewalk cafe shall be subject to the provisions of Section 10-28-800 through 10-28-885 of the Municipal Code of Chicago and the directions of the Commissioner of Department of Business Affairs and Consumer Protection, the Commissioner of Streets and Sanitation, and the Commissioner of Transportation.

The permit holder agrees to hold the City of Chicago harmless for any damage, relocation or replacement costs associated with damage, relocation or removal of private property caused by the City performing work in the public way.

Authority for the above named privilege is herein given and granted from and after March 1, 2014 through and including December 1, 2014.

Alderman _____



Harry Osterman 48th Ward



05/28/2014

Alderman **Harry Osterman**
Ward # **48**
City of Chicago
City Hall, Room **300**
121 North LaSalle Street
Chicago, Illinois 60602

Re: An ordinance to use and maintain a portion of the public right-of-way for **one (1) sidewalk cafe(s)** for **DEMERA ETHIOPIAN RESTAURANT**, adjacent to the premises known as **4801 N. Broadway** .

Dear Alderman **Harry Osterman**:

The applicant referenced above has requested the use of the public right-of-way for a **sidewalk cafe(s)**. An ordinance has been prepared by the Department of Business Affairs and Consumer Protection – Small Business Center - Public Way Use Unit for presentation to the City Council. Because this request was made for properties located in your ward, as approved by you as per the attached, I respectfully request that you introduce the attached ordinance at the next City Council meeting.

If you have any questions regarding this ordinance, please contact Anthony Bertuca at (312) 744-5506.

Department of Business Affairs and Consumer Protection



City of Chicago

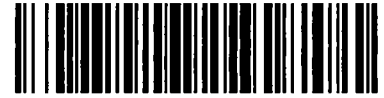

O2014-4704

Office of the City Clerk

Document Tracking Sheet

| | |
|---------------------------------|--|
| Meeting Date: | 5/28/2014 |
| Sponsor(s): | Osterman (48) |
| Type: | Ordinance |
| Title: | Sidewalk cafe(s) for Fiesta Mexicana Corp. |
| Committee(s) Assignment: | Committee on Transportation and Public Way |

ORDINANCE
FIESTA MEXICANA CORP
Acct. No. 3474 - 1
Permit No. 1113135

Be It Ordained by the City Council of the City of Chicago:

Permission and authority are hereby given and granted to FIESTA MEXICANA CORP upon the terms and subject to the conditions of this ordinance, to maintain and use a portion of the public right of way for a sidewalk cafe adjacent to its premises located at 4806 N. Broadway . Said sidewalk cafe area #1 shall be fifteen point five (15.5) feet in length and twelve (12) feet in width for a total of one hundred eighty-six (186) square feet and shall allow six (6) feet of clear space from the face of the curb/building line along N. Broadway. The compensation for said space and the days and hours of operation for the sidewalk cafe shall be as follows:

Monday through Sunday 11:00 a.m. to 12:00 a.m.
Compensation: \$600.00
SEATING CAPACITY: 16

Sidewalk Cafe Permit and approved plan must be posted at all times.

This grant of privilege #1113135 for a sidewalk cafe shall be subject to the provisions of Section 10-28-800 through 10-28-885 of the Municipal Code of Chicago and the directions of the Commissioner of Department of Business Affairs and Consumer Protection, the Commissioner of Streets and Sanitation, and the Commissioner of Transportation.

The permit holder agrees to hold the City of Chicago harmless for any damage, relocation or replacement costs associated with damage, relocation or removal of private property caused by the City performing work in the public way.

Authority for the above named privilege is herein given and granted from and after March 1, 2014 through and including December 1, 2014.

Alderman _____



Harry Osterman 48th Ward



Department of Business Affairs and Consumer Protection
Small Business Center - Public Way Use Unit
City Hall - 121 N. LaSalle Street, Room 800 • Chicago, IL 60602
(312)-74-GOBIZ (312-744-6249) • (312) 744-1944 (TTY)
<http://www.cityofchicago.org/bacp>

05/28/2014

Alderman **Harry Osterman**
Ward # **48**
City of Chicago
City Hall, Room 300
121 North LaSalle Street
Chicago, Illinois 60602

Re: An ordinance to use and maintain a portion of the public right-of-way for **one (1) sidewalk cafe(s)** for **FIESTA MEXICANA CORP**, adjacent to the premises known as **4806 N. Broadway** .

Dear Alderman **Harry Osterman**:

The applicant referenced above has requested the use of the public right-of-way for a **sidewalk cafe(s)**. An ordinance has been prepared by the Department of Business Affairs and Consumer Protection – Small Business Center - Public Way Use Unit for presentation to the City Council. Because this request was made for properties located in your ward, as approved by you as per the attached, I respectfully request that you introduce the attached ordinance at the next City Council meeting.

If you have any questions regarding this ordinance, please contact Anthony Bertuca at (312) 744-5506.

Department of Business Affairs and Consumer Protection



City of Chicago



O2014-4708

Office of the City Clerk

Document Tracking Sheet

| | |
|---------------------------------|--|
| Meeting Date: | 5/28/2014 |
| Sponsor(s): | Osterman (48) |
| Type: | Ordinance |
| Title: | Sidewalk cafe(s) for La Fonda Latino Grill |
| Committee(s) Assignment: | Committee on Transportation and Public Way |

ORDINANCE
LA FONDA LATINO GRILL
Acct. No. 216058 - 1
Permit No. 1113134

Be It Ordained by the City Council of the City of Chicago:

Permission and authority are hereby given and granted to LA FONDA LATINO GRILL upon the terms and subject to the conditions of this ordinance, to maintain and use a portion of the public right of way for a sidewalk cafe adjacent to its premises located at 5350 N. Broadway . Said sidewalk cafe area #1 shall be twenty-one (21) feet in length and ten (10) feet in width for a total of two hundred ten (210) square feet and shall allow six (6) feet of clear space from the face of the curb/building line along N. Broadway. The compensation for said space and the days and hours of operation for the sidewalk cafe shall be as follows:

Tuesday through Thursday 12:00 noon to 9:00 p.m. Friday and Saturday 12:00 noon to 9:30 p.m. Sunday 12:00 noon to 8:30 p.m.
Compensation: \$600.00
SEATING CAPACITY: 16

Sidewalk Cafe Permit and approved plan must be posted at all times.

This grant of privilege #1113134 for a sidewalk cafe shall be subject to the provisions of Section 10-28-800 through 10-28-885 of the Municipal Code of Chicago and the directions of the Commissioner of Department of Business Affairs and Consumer Protection, the Commissioner of Streets and Sanitation, and the Commissioner of Transportation.

The permit holder agrees to hold the City of Chicago harmless for any damage, relocation or replacement costs associated with damage, relocation or removal of private property caused by the City performing work in the public way.

Authority for the above named privilege is herein given and granted from and after March 1, 2014 through and including December 1, 2014.

Alderman _____



Harry Osterman 48th Ward



05/28/2014

Alderman **Harry Osterman**
Ward # **48**
City of Chicago
City Hall, Room **300**
121 North LaSalle Street
Chicago, Illinois 60602

Re: An ordinance to use and maintain a portion of the public right-of-way for **one (1) sidewalk cafe(s)** for **LA FONDA LATINO GRILL**, adjacent to the premises known as **5350 N. Broadway** .

Dear Alderman **Harry Osterman**:

The applicant referenced above has requested the use of the public right-of-way for a **sidewalk cafe(s)**. An ordinance has been prepared by the Department of Business Affairs and Consumer Protection – Small Business Center - Public Way Use Unit for presentation to the City Council. Because this request was made for properties located in your ward, as approved by you as per the attached, I respectfully request that you introduce the attached ordinance at the next City Council meeting.

If you have any questions regarding this ordinance, please contact Anthony Bertuca at (312) 744-5506.

Department of Business Affairs and Consumer Protection



City of Chicago



O2014-4711

Office of the City Clerk

Document Tracking Sheet

| | |
|---------------------------------|--|
| Meeting Date: | 5/28/2014 |
| Sponsor(s): | Moore (49) |
| Type: | Ordinance |
| Title: | Sidewalk cafe(s) for Chuckie's |
| Committee(s) Assignment: | Committee on Transportation and Public Way |

ORDINANCE
CHUCKIE'S
Acct. No. 352966 - 1
Permit No. 1113137

Be It Ordained by the City Council of the City of Chicago:

Permission and authority are hereby given and granted to CHUCKIE'S upon the terms and subject to the conditions of this ordinance, to maintain and use a portion of the public right of way for a sidewalk cafe adjacent to its premises located at 1412-1414 W. Morse Ave.. Said sidewalk cafe area #1 shall be forty-five (45) feet in length and eight (8) feet in width for a total of three hundred sixty (360) square feet and shall allow six (6) feet of clear space from the face of the curb/building line along W Morse Ave. The compensation for said space and the days and hours of operation for the sidewalk cafe shall be as follows:

Monday through Sunday 11:00 a.m. until 12:00 Midnight
Compensation: \$600.00
SEATING CAPACITY: 49

Sidewalk Cafe Permit and approved plan must be posted at all times.

This grant of privilege #1113137 for a sidewalk cafe shall be subject to the provisions of Section 10-28-800 through 10-28-885 of the Municipal Code of Chicago and the directions of the Commissioner of Department of Business Affairs and Consumer Protection, the Commissioner of Streets and Sanitation, and the Commissioner of Transportation.

The permit holder agrees to hold the City of Chicago harmless for any damage, relocation or replacement costs associated with damage, relocation or removal of private property caused by the City performing work in the public way.

Authority for the above named privilege is herein given and granted from and after March 1, 2014 through and including December 1, 2014.

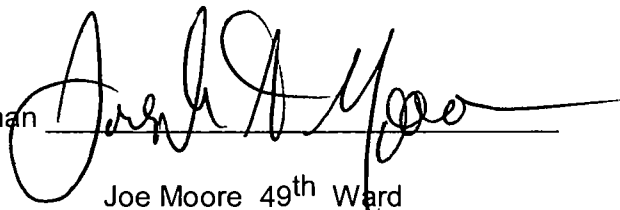
Alderman 
Joe Moore 49th Ward



05/28/2014

Alderman **Joe Moore**
Ward # **49**
City of Chicago
City Hall, Room **300**
121 North LaSalle Street
Chicago, Illinois 60602

Re: An ordinance to use and maintain a portion of the public right-of-way for **one (1) sidewalk cafe(s)** for **CHUCKIE'S**, adjacent to the premises known as **1412-1414 W. Morse Ave.**.

Dear Alderman **Joe Moore**:

The applicant referenced above has requested the use of the public right-of-way for a **sidewalk cafe(s)**. An ordinance has been prepared by the Department of Business Affairs and Consumer Protection – Small Business Center - Public Way Use Unit for presentation to the City Council. Because this request was made for properties located in your ward, as approved by you as per the attached, I respectfully request that you introduce the attached ordinance at the next City Council meeting.

If you have any questions regarding this ordinance, please contact Anthony Bertuca at (312) 744-5506.

Department of Business Affairs and Consumer Protection



City of Chicago



Or2014-242

Office of the City Clerk

Document Tracking Sheet

| | |
|---------------------------------|---|
| Meeting Date: | 5/28/2014 |
| Sponsor(s): | Fioretti (2) |
| Type: | Order |
| Title: | Issuance of permits for sign(s)/signboard(s) at 829 S Wabash Ave |
| Committee(s) Assignment: | Committee on Zoning, Landmarks and Building Standards |

(signs)

ORDERED, That the Commissioner of Buildings is hereby directed to issue a sign permit to: (Contractor's name and address)

BEST NEON SIGN CO.
6025 S. NEW ENGLAND
CHICAGO IL. 60638

for the erection of a sign/signboard over 24 feet in height and/or over 100 square feet (in area of one face) at: (Business address)

829 S. Wabash Avenue, Chicago, IL 60605

Dimensions: length 30'-0" height 2'-4"

height above grade/roof to top of sign 165

TOTAL SQUARE FOOT AREA 165

Such sign(s)

shall comply with all applicable provisions of Chapter 194A of the Chicago Zoning Ordinance and all other applicable provisions of the Municipal Code of the City of Chicago governing the construction and maintenance of outdoor signs, signboards and structures.

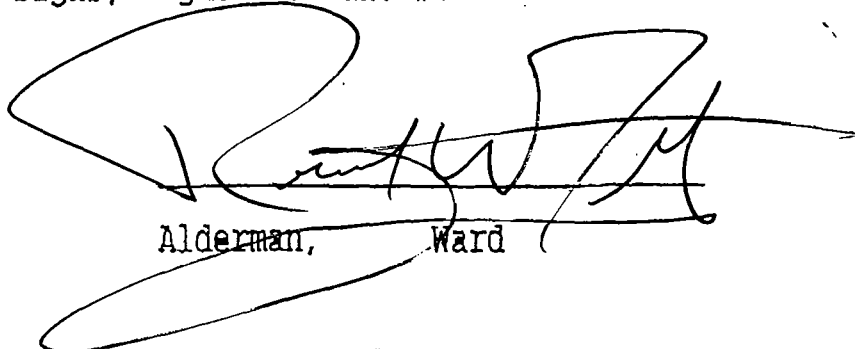

Alderman, Ward



CITY OF CHICAGO

DEPARTMENT OF BUILDINGS

Sign Permit Application

| | | | | | | | |
|---|---------------------------------|--|---------------|--|------------|----------|----------|
| APPROVAL NUMBER | APPLICATION NUMBER 100521123 | ANNUAL FEE | WORK CODE | DRAWINGS ATTACHED <input checked="" type="checkbox"/> YES <input type="checkbox"/> NO | | | |
| DATE OF APPLICATION 12/12/2013 | | TYPE OF SIGN FLAT OR BOX | | | | | |
| ADDRESS OF SIGN 829 S WABASH AVE, 60605- | | LENGTH | FT. 30 | IN. 0 | HEIGHT | FT. 2 | IN. 4 |
| BUILDING | ORIGINAL PERMIT NUMBER | AREA | SQ. FT. 70 | WEIGHT | LBS 310 | | |
| TYPE OF PERMIT NEW CONSTRUCTION (SIGN) | | SIGN HEIGHT ABOVE GRADE/ROOF | | | FT. 165 | | |
| PAYER OF ANNUAL INSPECTION MALIK, ZAFAR 816 S. MICHIGAN CHICAGO, IL 60605 (312)939-0111 | | SHAPE OF SIGN REGULAR | | | | | |
| SIGN MANUFACTURER BEST NEON SIGN COMPANY | | SIGN WILL READ EAST-WEST UNIVERSITY | | | | | |
| ADDRESS WHERE SIGN CAN BE SEEN PRIOR TO ERECTION | | NO OF LAMPS 1 | | TOTAL WATTAGE 240 | | | |
| TICKET NUMBER 0 | | REINSPECTION CONTROL NUMBER | | TYPE OF LAMP OTHER | | | |
| TYPE OF SUPPORT FOR SIGN BUILDING | | NO. OF BALLAST/TRANSFORMERS 4 | | INPUT OF TRANSFORMERS 110 | | | |
| SIGN BOARD SUPPORT MEMBERS STEEL | | CONTRACTOR WILL INSTALL | | <input checked="" type="checkbox"/> FEEDERS <input type="checkbox"/> CUSTOMER LEADS | | | |
| ANNUAL FEE | | TYPE OF SWITCH KNIFE | | | | | |
| CONSTRUCTION FEE 200.00 | | LOCATION OF SWITCH OUTSIDE SIGN | | | | | |
| 1017 B FEE | | SIGN LOCATION NORTH WALL OF BUILDING-17TH FLOOR | | | | | |
| TOTAL FEE 200.00 | | Check # for Zoning | | | | | |
| AMOUNT PAID 200.00 | | Check # for DCAP | | | | | |
| BALANCE DUE | | | | | | | |

The undersigned certify that the statements in this application are true and correct; and that all work done under the proposed permit will conform to the requirements of the Chicago Municipal Code.

| | | | |
|----------------------|--|--------------|---|
| REG. NO | E20553 | BOND. NO. | N90352 |
| ELECT CONTR | BEST NEON SIGN CO. | SIGN ERECTOR | BEST NEON SIGN CO |
| ADDRESS | 6025 S. NEW ENGLAND AVE. CHICAGO, IL 60638- | ADDRESS | 6025 S. NEW ENGLAND AV CHICAGO X IL, 60638 |
| SUPERVISOR SIGNATURE | | SIGNATURE | |

The permit issued on this application will authorize only signs here applied for. If other signs are to be erected they must be covered by additional permits.

City of Chicago
Rahm Emanuel, Mayor



Department of Buildings
Michael Merchant, Commissioner

| | |
|---|--|
| TYPE OF BUSINESS <u>PAC COLLEGE</u> Other: <u>UNIVERSITY</u> Name: <u>EAST-WEST UNIVERSITY</u> LIC #: <u>26053</u> Renewal Date: _____ | SIGN BOND REQUIRED? <input type="checkbox"/> YES COUNCIL ORDER REQUIRED <input type="checkbox"/> YES IS SPECIAL PERMISSION REQUIRED FROM CHIEF ELECTRICAL <input type="checkbox"/> YES IF YES, ATTACH LETTER OF REQUEST TIME STAMP |
| Projects Over: <input checked="" type="checkbox"/> Private Property <input checked="" type="checkbox"/> Public Way Grant Permit #: _____ <input type="checkbox"/> Planned Development/Manufacturing PMD/PD#: _____ Zoning District: <u>DX</u> Other: <u>DX-12</u> | IF YES, ATTACH LETTER OF REQUEST TIME STAMP |
| TYPE OF SIGN: <input type="checkbox"/> ADVERTISING <input checked="" type="checkbox"/> ILLUMINATE <input type="checkbox"/> MOVEABLE <input checked="" type="checkbox"/> BUSINESS <input type="checkbox"/> FLASHING | TIME STAMP |
| TOTAL STREET FRONTAGE OF LOT (IN FEET) <u>100</u> TOTAL AREA OF NEW SIGN (SQ.FT.) <u>70</u> TOTAL AREA OF ALL SIGNS ON LOT (SQ.FT.) <u>72</u> HEIGHT OF SIGN ABOVE GRADE (TO TOP) <u>167ft 4in</u> | TIME STAMP |
| DISTANCE OF CURB LINE OUTER EDGE (ft) <u>100</u> DISTANCE OF STRUCTURE INNER EDGE (ft) <u>1</u> | SIGN CLERK _____ APPROVED FOR PERMIT _____ |
| DISTANCE FROM (ft): A. PUBLIC PARK (OVER 10 ACRES) _____ B. EXPRESSWAY (IF LESS THAN 1,000 FT.) _____ C. RESIDENCE DISTRICT (ADVERTISING SIGNS ONLY) _____ | REMARKS |
| IF REPLACEMENT SIGN OR CHANGE OF FACE, WHAT DOES THE EXISTING SIGN READ? Original Payee: _____ Landmark Hold: <input type="checkbox"/> Status: _____ | REMARKS <div style="text-align: center; border: 2px solid black; padding: 10px; transform: rotate(-10deg); width: fit-content; margin: 20px auto;"> APPROVED JAN 8 9 2014 PUBLIC WAY USE </div> |
| ZONING (OFFICE USE ONLY) <div style="text-align: center; margin-top: 20px;"> <p>CONFORMS TO ZONING ORDINANCE This Approval of Application for signs shall not be held to permit or be an approval of any violation of the provisions.</p> <p>MAR 26 2014</p> <p>of the Chicago Zoning Ordinance, or any other requirements of the Municipal Code of the City of Chicago ZONING ADMINISTRATOR</p> </div> | REMARKS |

| 28" |

EAST-WEST UNIVERSITY

| 30' |

**FRONT-LIT PLEX-FACE CHANNEL LETTERS
17TH FLOOR. APPROX. 170' FROM GRADE
SHOWN ON BUILDING**

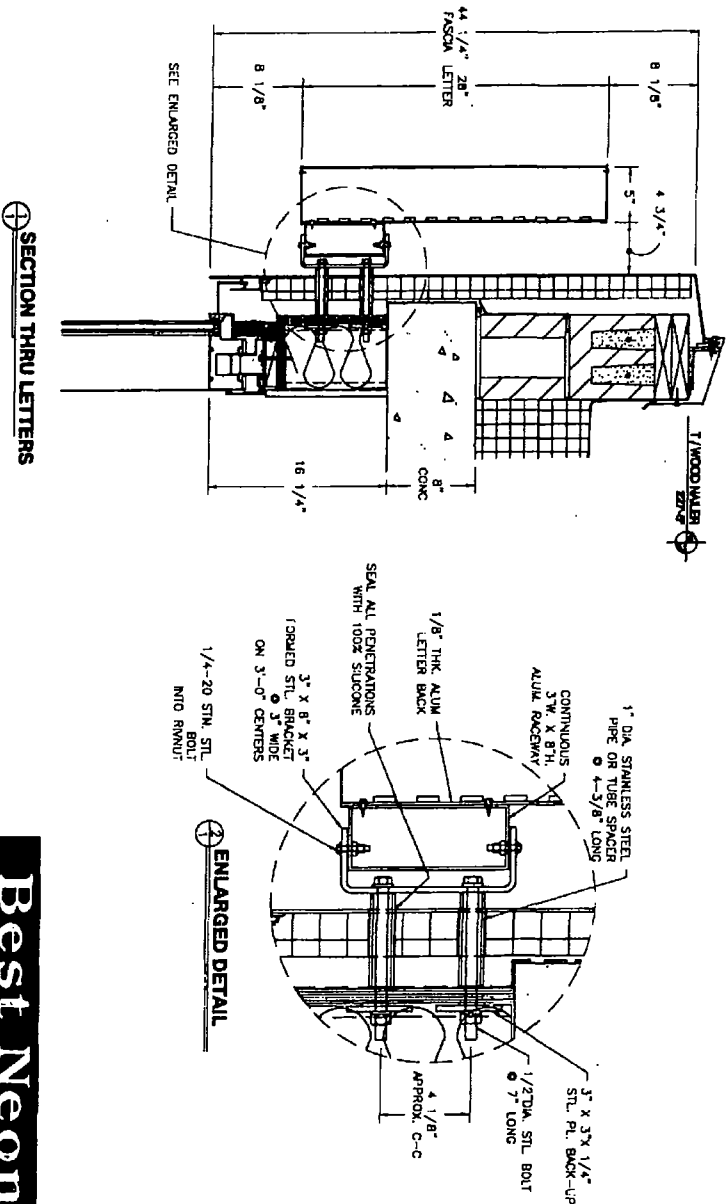

PLEASE PRINT
 By signing the approval box on this sketch, I understand that I am accepting all aspects of this drawing. This includes artwork, specifications, dimensions, spelling and any other representations herein. I also understand that color representations on this sketch are approximate, and may not match manufactured product exactly.

Best Neon Sign

SCALE NO SCALE OR N/A ENU
 CUSTOMER EAST WEST UNIVERSITY
 ADDRESS 820 S. WALBASH
 CITY CHICAGO
 STATE IL
 ARTIST MICHAEL
 DATE 12/18/13
 APPROVED _____
 CUSTOMER APPROVAL: _____

**CITY OF CHICAGO
DEPARTMENT OF ZONING AND LAND USE PLANNING
SIGN SITE PLAN**

(ALL INFORMATION MUST BE COMPLETED AND LEGIBLE)

Site Address: 829 South Wabash St. 1 of 1 applications
 Sign Company: Best Neon Sign Co. Rep Name: Steve G.
 Phone (773) 586-2700 EXT — (Below: Building, streets and location of sign on lot or structure)
 North

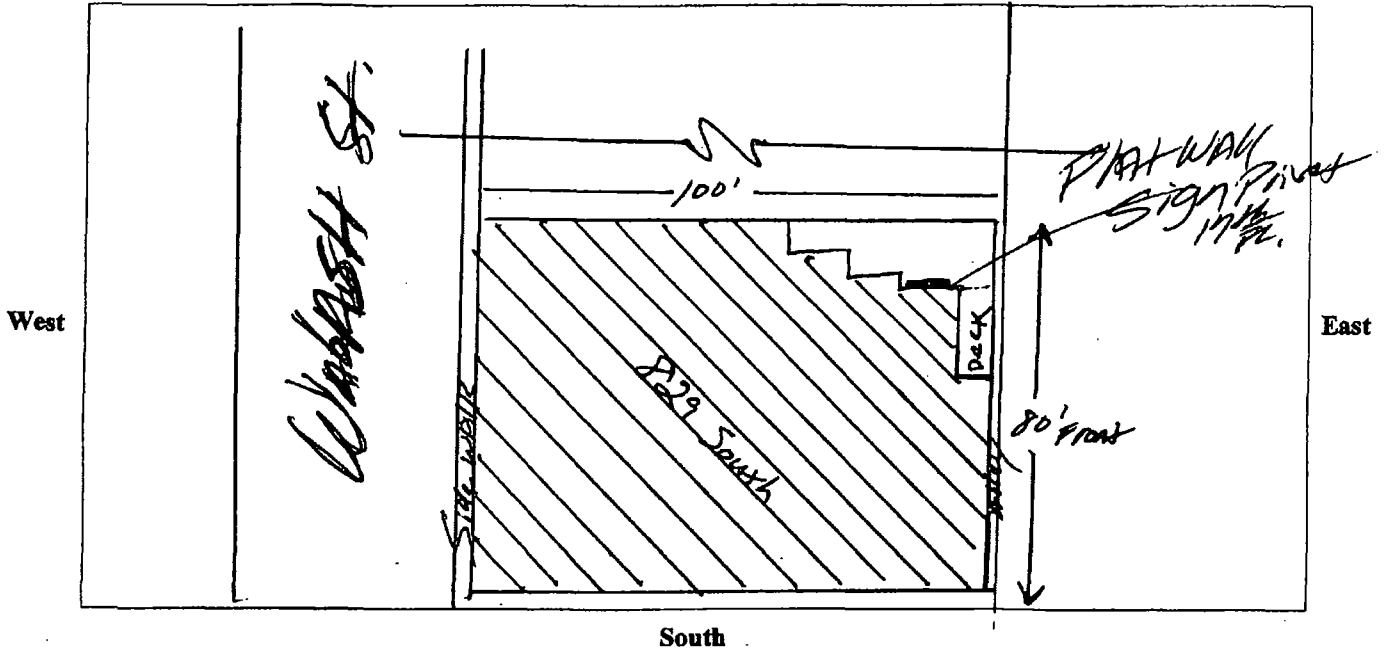

SIGN USE:
 Bus. ID (On-premise)
 Business Lice. # Account # 26053
 Advertising (Off-premise)

TYPE OF SIGN:
 Flat Wall
 Freestanding
 Awning
 Marquee
 High Rise Building
 Projecting Private
 Projecting Public Way
 Public Way Use - Permit # Private

SIGN CHARACTERISTICS:
 Non- Illuminated
 Illuminated
 Changing Image
 Video Display
 Flashing

PERMIT TYPE:
 New Construction
 Change of Face
 Previous Permit #

DISTANCE FROM:
 Curb Line: over 100'
 Expressway, Toll Roads
 or Major Route
 (n/a if over 1000 ft) N/A
 Park (over 10 acres) 0
 Residential Zone 0
 Existing Off-premise on
 same side of street: 0

TOTAL SQUARE FOOTAGE:
 Square footage of this proposed sign 72
 Gross area of all proposed signs 72
 Area of all existing signs
 (not including proposed) on Zoning Lot 0

Signature: [Signature]
 (Revised 4/10)

Date: 12-12-13



City of Chicago



Or2014-228

Office of the City Clerk

Document Tracking Sheet

| | |
|---------------------------------|---|
| Meeting Date: | 5/28/2014 |
| Sponsor(s): | Harris (8) |
| Type: | Order |
| Title: | Issuance of permits for sign(s)/signboard(s) at 9000 S Stony Island Ave |
| Committee(s) Assignment: | Committee on Zoning, Landmarks and Building Standards |

Committee on Zoning, Landmarks, and Building Standards

ORDERED, That the Commissioner of Buildings is hereby directed to issue a sign permit to:

Midwest Sign & Lighting, Inc.

4910 W. WILSHIRE BLVD.

COUNTRY CLUB HILLS, IL 60448

For the erection of sign / signboard over 24 feet in height and / or over 100 square feet (in area of one face) at:

**PRESENCE MEDICAL
9000 S, STONY ISLAND AVENUE
CHICAGO, IL 60617**

Dimensions: Length 34'-3 1/2" Height 4'

Height above grade / roof to top of sign 11' TO BOTTOM OF SIGN FROM GRADE

TOTAL SQUARE FOOT AREA 137 SQUARE FEET

Such Sign (s) shall comply with all applicable provisions of Title 17 of the Chicago Zoning Ordinance and all other Applicable provisions of the Municipal Code of the City of Chicago Governing the construction and maintenance of outdoor signs, sign boards and structures.

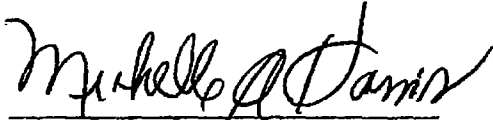
Alderman Approval



APPLICATION CHECKLIST (continued)

Acceptance Letter

ACCEPTANCE OF GRANT OF PRIVILEGE PERMIT TERMS

I hereby understand and accept the terms and conditions relative to the issuance of the permit, and by signing below, I acknowledge the receipt of a copy of the Municipal Code of Chicago's 10-28 and 13-20 regulations, as well as all the additional requirements promulgated herein:

I understand it shall be my duty as the permit holder, and as a condition of the permit, to:

1. Comply with all the requirements defined within Chicago's Municipal Code, the Rules and Regulations, as well as the requirements promulgated herein;
2. Upon the passage of the permit ordinance at City Council, pay the non-refundable applicable Grant of Privilege annual permit fee .
3. Upon the submission of the permit application the applicant shall furnish the certificate of insurance; and,
4. Resolve all Account Holds since failure to do so will prevent the processing of this permit application;
5. Install or maintain the grant of privilege after the issuance of the permit by the Commissioner of Business Affairs and Consumer Protection;

- I hereby agree to accept the terms and conditions relative to issuance of the permit.
- I agree to renew the Certificate of Insurance at least 10 days prior to expiration of the policy.
- I understand that if the item or items are not constructed/maintained the permit fees will not be refunded.

I understand that failure to adhere to all conditions imposed in the permit may result in revocation of the permit.

SIGNATURE: *Bob Hauptman* DATE: _____
 PRINT NAME: BOB HAUPTMAN TITLE: Vice President

ACCOUNT #: _____ SITE #: _____
 LEGAL NAME OF ENTITY: Presence Health
 BUSINESS NAME (DBA): Presence Health
 BUSINESS LOCATION ADDRESS: 9000 STONY ISLAND
 CITY: Chicago STATE: Illinois ZIP CODE: _____
 BUSINESS PHONE: 847-668-8525
 E-MAIL: _____ PERMIT TYPE: PUBLIC WAY





APPLICATION TO USE THE PUBLIC RIGHT OF WAY

APPLICANT INFORMATION

- LEGAL NAME OF ENTITY: Presence Health
 - PERMIT MAILING ADDRESS: 5747 Dempster
 - CITY: Morton Grove STATE: IL ZIP CODE: 60053
 - CONTACT PERSON: LARRY LATAS TITLE: Syst. Director
 - PHONE: 847-568-8525 FAX: 847-568-8545 E-MAIL: L.LATAS@PresenceHealth.Org

BUILDING OWNER INFORMATION

- NAME: Presence Health
 - ADDRESS: 5747 Dempster
 - CITY: Morton Grove STATE: IL ZIP CODE: 60053
 - PHONE: 847-568-8525 FAX: 847-568-8549 E-MAIL: L.LATAS@PresenceHealth.Org

USE OF THE PUBLIC WAY

- List the proposed or existing use below and complete the worksheet on page 3. Use only one application for all public way use type.

| TYPE | HOW MANY? | BUILDING ADDRESS |
|-------------|------------|--------------------------|
| <u>SIGN</u> | <u>ONE</u> | <u>9000 STONY ISLAND</u> |
| | | |
| | | |

- Please enclose one sketch of each proposed use of the public way, which maps to scale the proposed use(s) and its relationship to surrounding right-of-way. All measurements must be indicated. The prints should also accurately depict the location of the property line and public facilities (meters, light poles, sidewalks).

APPLICANT CERTIFICATION

I hereby certify that all statements made as part of the application, and the attachments herein, are true to the best of my knowledge and belief.

- BY: Richard M. Houghton TITLE: System's President
 - F.E.I.N. or SOCIAL SECURITY NUMBER: _____

ALDERMAN'S APPROVAL

As part of this application process, you are required to notify/seek approval from the Alderman in whose ward your proposed use of the public way is located.

ALDERMAN'S SIGNATURE: Michelle A. Harris
 DATE: 4/29/14 WARD: 8th

Approval shall not be withheld for any reason relating to the language, content or message contained in or omitted by the sign, canopy, awning, banner or marquee for which the permit is sought. If a downward signature indicating approval is not received by BACP within 60 days of the business of the application to the Alderman that, provided the application is complete and accurate and the applicant is not in violation of any pertinent provision of the Municipal Code, the applicant shall be deemed approved by the BACP and protected for submission to the City Council as a Mayor's ordinance.

Approve | Reason(s): _____
 Do Not Approve | Reason(s): _____





APPLICATION TO USE THE PUBLIC RIGHT OF WAY

APPLICATION WORKSHEET

- For use by **NEW APPLICANTS ONLY**.
- For renewals obtain form from City Hall, 121 N. LaSalle St., Rm. 800 or call (312) 74 - GOBIZ (744-6249)

Complete the worksheet for each use of the public way and indicate all applicable measurements.

| | Exact Street (i.e. S. State St.) | Quantity | Length of structure along public way | Height of structure | Depth of structure | Height above grade | Total depth over public way | Is this sign(s) illuminated? (Y/N) | Is this an Existing Public Way Use (Y/N) |
|------------------|-------------------------------------|----------|--|---------------------|--------------------|-----------------------|--------------------------------|--|--|
| SIGNS | 9000 STONY ISLAND | 1 | 34'-3 1/2" | 4' 6" | | 11' 6" | | Y | N |
| | | | | | | | | | |
| | | | | | | | | | |
| CANOPIES/AWNINGS | | | | | | | | | |
| | | | | | | | | | |
| | | | | | | | | | |
| LIGHTS | | | | | | | | | |
| | | | | | | | | | |
| | | | | | | | | | |

See example of required plans beginning on the next page.

NOTE: Pursuant to section 2-154-030 of the Municipal Code of the City of Chicago the Corporation Counsel of the City of Chicago may require any such additional information from any applicant to achieve full disclosure relevant to the request for action by the City Council or other city agency. Pursuant to section 2-154-020 of the Municipal code of the City of Chicago any material change in the information required above must be provided by supplementing this statement at any time up to the time the City Council or any city agency takes action on the application.



APPLICATION TO USE THE PUBLIC RIGHT OF WAY

EXAMPLE OF SIGN DRAWING

SIGN DRAWING

PROPERTY LOCATION: 9000 STONY ISLAND

ORGANIZATION(S) NAME: PRESENCE MEDICAL GROUP

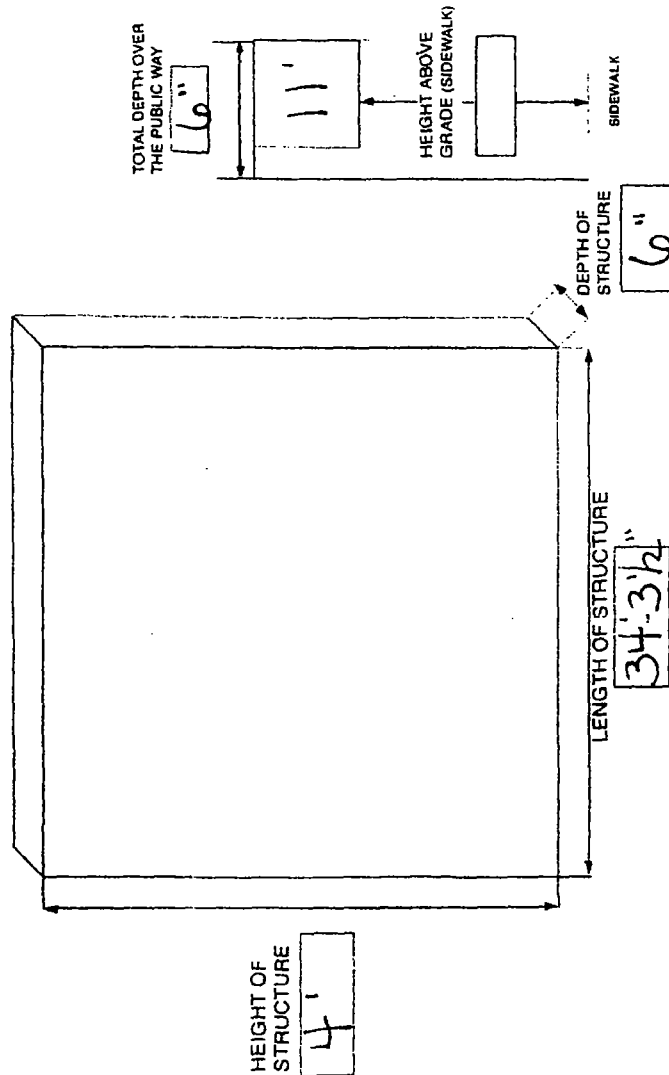

SIGN SPECIFICATIONS

(A) - ILLUMINATED LETTERS

Lighting: LED
 Voltage: 120V
 Description: Face-Lit (Acrylic) Raceway
 paint to match PMS 7518c
 Face Color: White
 Return Color: P3
 Installer: letters flush to raceway

(B) - ILLUMINATED LOGO

Lighting: LED
 Voltage: 120V
 Description: Face-Lit (Acrylic) Raceway
 paint to match PMS 7518c
 Face Color: White
 Return Color: P3
 Trimcap Color: P3
 Installer: Logo flush to raceway

(C) - GRAPHICS/LOGO
 Vinyl Graphics VS, V6, (2 x V7), V8
 leaving thin white outline
 to eliminate night heaving

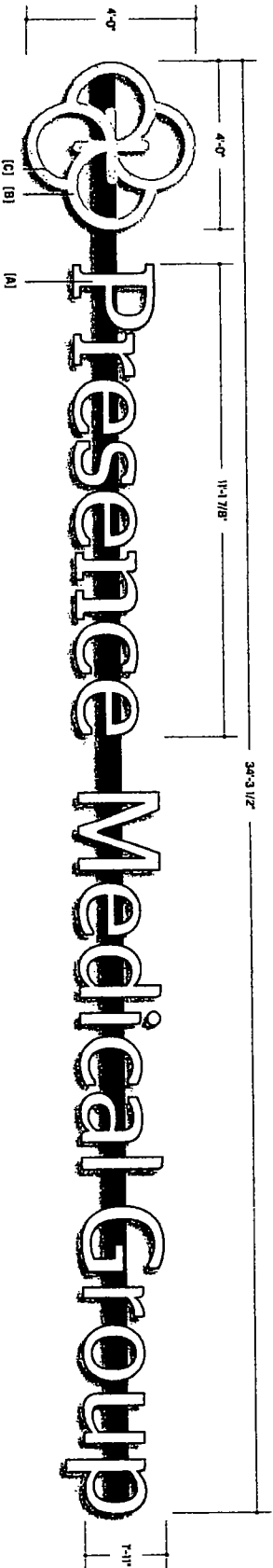
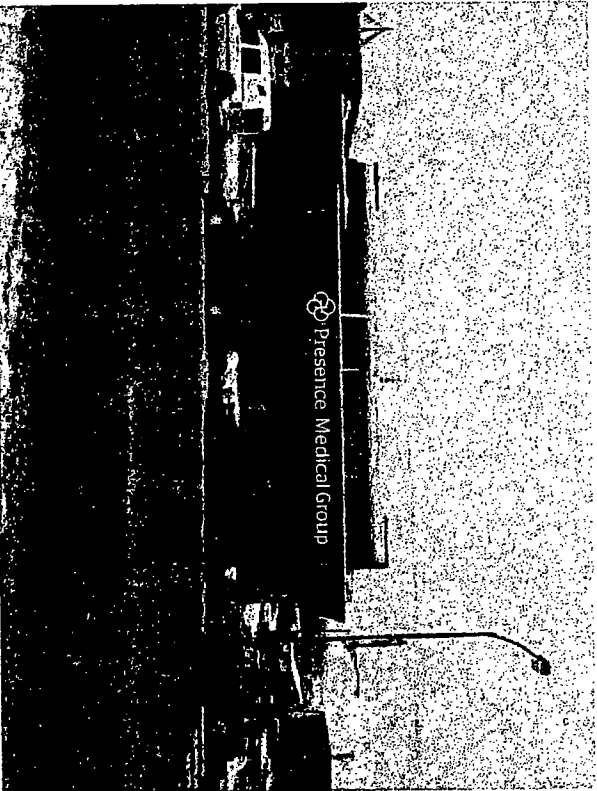
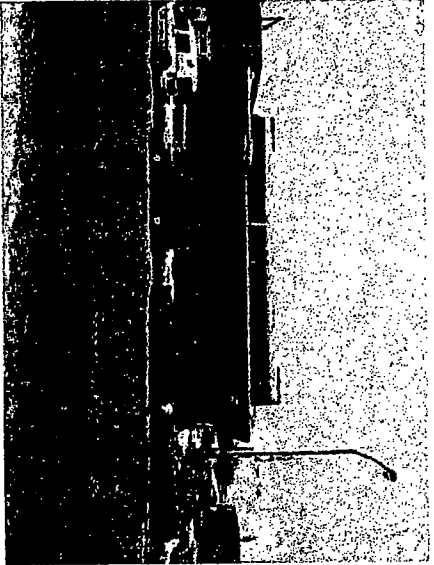

Vinyl detail cabinet



800 S. North St. Westfield, MA 01095
 413.453.4010 www.poblocki.com

The information provided by POBLOCKI is intended for informational purposes only. It is not intended to be used as a contract. The actual specifications for the project will be provided by the client. POBLOCKI is not responsible for any errors or omissions in this document. All rights reserved. © 2013 POBLOCKI. All other trademarks are the property of their respective owners.

Project

Presence - PMH

9000 S. Stony Island Avenue
 Chicago, IL 60617

Scale: 1/4" = 1'-0"
 Original Page Size: 11" x 17"

Notes

Remove ribs as needed to mount
 raceway flush to wall

| Revision | BY | DATE |
|-----------------|-----|----------|
| REV DESCRIPTION | REV | DATE |
| 01 create/signs | KSW | 12/20/13 |
| 02 correction | KSW | 02/21/14 |
| 03 clarify info | SKM | 02/24/14 |

By: Katie Conroy
 Design By: Sarah Watson
 01/05/14 11/25/13

Sign Location:

PL123rwi
 Lit Letters
 Sign Type

63926 101
 01/05/14 11/25/13

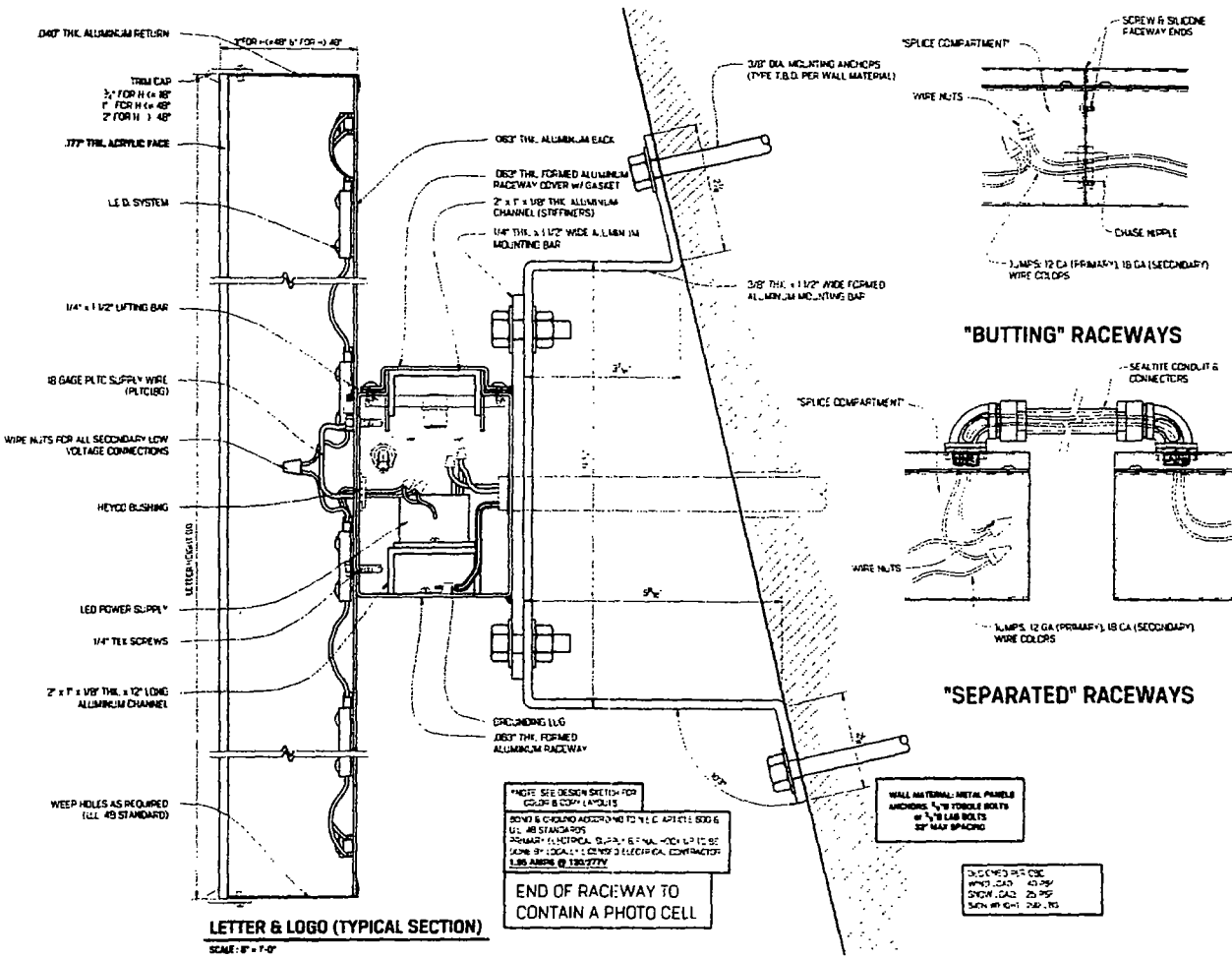

This document is prepared by and for the exclusive use of the client. It is not to be distributed, copied, or otherwise used by any other party without the prior written consent of Poblocki Engineering, Inc. All rights reserved. © 2010 Poblocki Engineering, Inc. All other rights reserved. This document is the property of Poblocki Engineering, Inc.

PROJECT:
PRESENCE - PMG
 8000 S STONY ISLAND AVENUE
 CHICAGO, IL

SCALE: AS NOTED
 Change Page Size: 11" x 17"
 Notes:

| REV. | DESCRIPTION | BY | DATE |
|------|----------------|-----|----------|
| 1 | ISSUED FOR RFP | WPK | 03/14/10 |



City of Chicago



Or2014-229

Office of the City Clerk

Document Tracking Sheet

| | |
|---------------------------------|---|
| Meeting Date: | 5/28/2014 |
| Sponsor(s): | Balcer (11) |
| Type: | Order |
| Title: | Issuance of permits for sign(s)/signboard(s) at 2201 S Halsted St - north wall |
| Committee(s) Assignment: | Committee on Zoning, Landmarks and Building Standards |

CITY COUNCIL MEETING:
Introduced May 28, 2014

Ordered, That the commissioner of buildings is hereby authorized and directed to issue

A sign permit to: **Gracie Group**
 3057 N. Rockwell
 Chicago, IL 60618

For the erection of a sign/signboard over 24 feet in height and /over 100 square feet

(in area of one face) at:

2201 S. Halsted St. (North Wall)

Dimensions: Length **48' 0'** Height **14'0"**

Height above grade/roof to top of sign **70'0"**

TOTAL SQUARE FOOT AREA 672'

Such sign(s) shall comply with all applicable provisions of TITLE 17 of the Chicago Zoning Ordinance and all other applicable provisions of the Municipal Code of the City of Chicago governing the construction and maintenance of outdoor signs, signboards and structures.

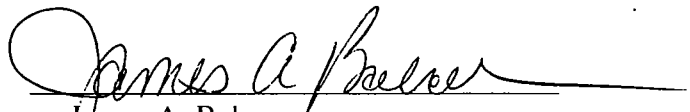
James A. Balcer
Alderman, 11th Ward



City of Chicago



Or2014-230

Office of the City Clerk

Document Tracking Sheet

| | |
|---------------------------------|---|
| Meeting Date: | 5/28/2014 |
| Sponsor(s): | Balcer (11) |
| Type: | Order |
| Title: | Issuance of permits for sign(s)/signboard(s) at 2201 S Halsted St - southeast wall |
| Committee(s) Assignment: | Committee on Zoning, Landmarks and Building Standards |

CITY COUNCIL MEETING:
Introduced May 28, 2014

Ordered, That the commissioner of buildings is hereby authorized and directed to issue

A sign permit to: **Gracie Group**
 3057 N. Rockwell
 Chicago, IL 60618

For the erection of a sign/signboard over 24 feet in height and /over 100 square feet
(in area of one face) at:

2201 S. Halsted St. (Southeast wall)

Dimensions: Length **48' 0'** Height **14'0"**

Height above grade/roof to top of sign **70'0**

TOTAL SQUARE FOOT AREA 672'

Such sign(s) shall comply with all applicable provisions of TITLE 17 of the Chicago Zoning Ordinance and all other applicable provisions of the Municipal Code of the City of Chicago governing the construction and maintenance of outdoor signs, signboards and structures.

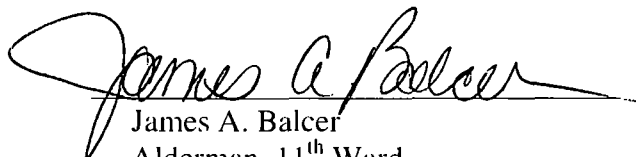
James A. Balcer
Alderman, 11th Ward



City of Chicago

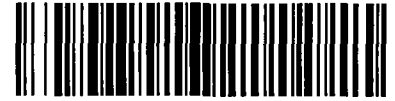

Or2014-225

Office of the City Clerk

Document Tracking Sheet

| | |
|---------------------------------|--|
| Meeting Date: | 5/28/2014 |
| Sponsor(s): | Lane (18) |
| Type: | Order |
| Title: | Issuance of permits for sign(s)/signboard(s) at 7601 S Cicero Ave - 502 sq. ft. |
| Committee(s) Assignment: | Committee on Zoning, Landmarks and Building Standards |

Committee on Zoning, Landmarks, and Building Standards

(Signs)

ORDERED, That the Commissioner of Buildings is hereby directed to issue a sign permit to: (Contractor's name and address)

Sure Light Sign Company
260 Knox Park Road
Lake Zurich, IL 60047

for the erection of a sign/signboard over 24 feet in height and/or over 100 square feet (in area of one face) at: (Business Name & Address)

American Multi-Cinema, Inc. (AMC) *Permit # 100538203*
7601 S. Cicero Ave.
Chicago, IL 60652

Dimensions: Length 27'-6" **Height** 18'-3"
Height above grade/roof to top of sign 21'-3"
TOTAL SQUARE FOOT AREA: 502

Such sign(s) shall comply with all applicable provisions of TITLE 17 of the Chicago Zoning Ordinance and all other applicable provisions of the Municipal Code of the City of Chicago governing the construction and maintenance of outdoor signs, signboards and structures.

Lona Lane, 18th Ward
Alderman Lane Ward 18



| |
|--|
| 13-1504 R3 |
| Sheet 3 of 4 |
| AMC Ford City 14 |
| 7801 S. Clewaco Ave Chicago, IL 60632 |
| Art. No. 7801 S. Clewaco Ave |
| Designer G. Guberman |
| Date 12/19/13 |
| Client AMC |
| Contract 13-1504 R3 |
| Project 7801 S. Clewaco Ave |
| Location Chicago, IL |
| Architect G. Guberman |
| Engineer G. Guberman |
| Manufacturer G. Guberman |

FOR THE RECORD: Please refer to drawings of this project for the correct dimensions and materials to be used. This drawing is for informational purposes only.

| |
|---------------------------------------|
| Glendale Signs |
| 1315 W. 11th St. Chicago, IL 60607 |
| Phone: (773) 442-1111 |
| Fax: (773) 442-1112 |
| Website: www.glendale-signs.com |
| 1315 W. 11th St. Chicago, IL 60607 |
| Phone: (773) 442-1111 |
| Fax: (773) 442-1112 |
| Website: www.glendale-signs.com |

FINAL ELECTRICAL CONNECTION BY CUSTOMER

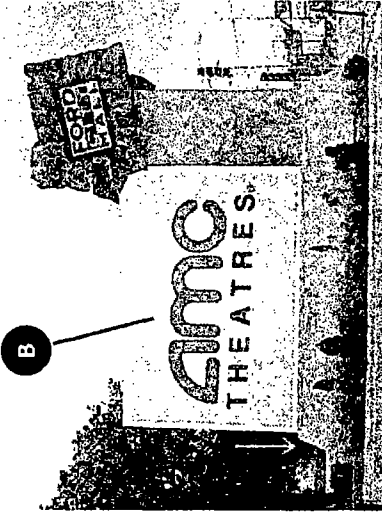

PHOTO SURVEY - AFTER NTS

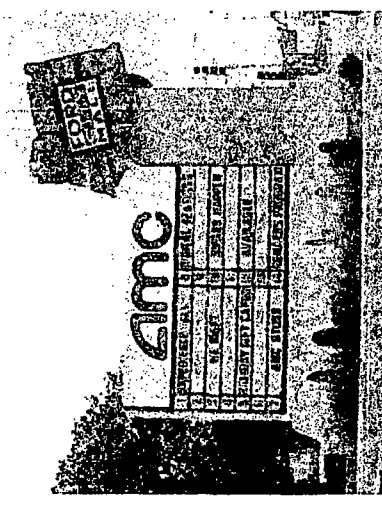
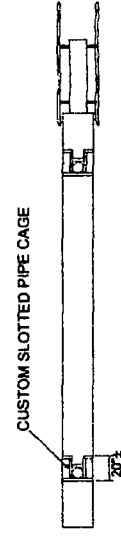
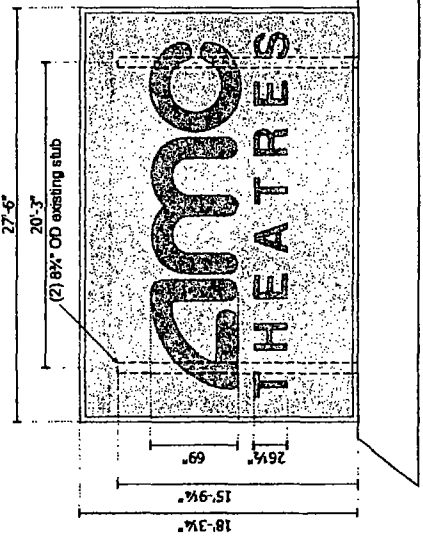

PHOTO SURVEY - BEFORE NTS



CUSTOM SLOTTED PIPE CAGE

REMOVE EXISTING CABINET.
REPLACE WITH NEW D/F CABINET.
4" RETAINERS, FILLER ALL PTD. WHITE
WHITE FLEX FACES WITH PRINTED GRAPHICS.
INTERNALLY ILLUMINATED WITH WHITE LEDS.
SIGN INSTALLS OVER EXISTING SUPPORT STEEL PIPES
AND IS DROPPED IN AND SLID TOWARDS "FORD CITY MALL" ID ELEMENT.



D/F Sign Detail

END VIEW

24" OD stub

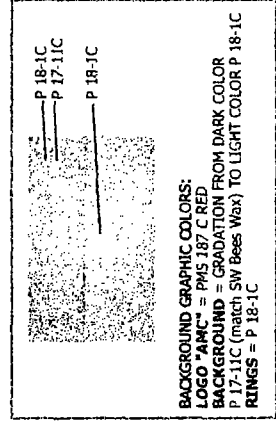

SCALE: 1/8" = 1'-0"
50' FT. 502.45'

(1) REQUIRED - MANUFACTURE AND INSTALL

COPY for Ald. Lane.



CITY OF CHICAGO

DEPARTMENT OF BUILDINGS

Sign Permit Application

| | | | | | | | | |
|---|---------------------------------|------------|---|--|---------|---|-------------|---------|
| APPROVAL NUMBER | APPLICATION NUMBER 100538203 | ANNUAL FEE | WORK CODE | DRAWINGS ATTACHED <input type="checkbox"/> YES <input type="checkbox"/> NO | | | | |
| DATE OF APPLICATION 04/29/2014 | | | TYPE OF SIGN FLAT OR BOX | | | | | |
| ADDRESS OF SIGN 7601 S CICERO AVE, 60652- | | | LENGTH | FT 27 | IN 6 | HEIGHT | FT 18 | IN 3 |
| BUILDING | ORIGINAL PERMIT NUMBER | | AREA | SQ FT 502 | WEIGHT | | LBS. 900 | |
| TYPE OF PERMIT NEW CONSTRUCTION (SIGN) | | | SIGN HEIGHT ABOVE GRADE/ROOF | | | FT. 3 | | |
| PAYER OF ANNUAL INSPECTION AMERICAN MULTI-CINEMA, INC., 4440 W. 77TH ST., FLOOR 1 CHICAGO, IL 60652 (773)555-5555 | | | SHAPE OF SIGN REGULAR | | | | | |
| SIGN MANUFACTURER CHANDLER SIGNS | | | SIGN WILL READ AMC THEATRES | | | | | |
| ADDRESS WHERE SIGN CAN BE SEEN PRIOR TO ERECTION | | | NO OF LAMPS 540 | | | TOTAL WATTAGE 1020 | | |
| TICKET NUMBER 0 | | | REINSPECTION CONTROL NUMBER | | | TYPE OF LAMP OTHER | | |
| TYPE OF SUPPORT FOR SIGN GROUND STRUCTURE | | | NO. OF BALLAST/TRANSFORMERS 8 | | | INPUT OF TRANSFORMERS 120 | | |
| SIGN BOARD SUPPORT MEMBERS STEEL | | | CONTRACTOR WILL INSTALL | | | <input checked="" type="checkbox"/> FEEDERS <input checked="" type="checkbox"/> CUSTOMER LEADS | | |
| ANNUAL FEE | | | TYPE OF SWITCH SPECIAL | | | | | |
| CONSTRUCTION FEE 200.00 | | | LOCATION OF SWITCH OUTSIDE SIGN | | | | | |
| 1017 B FEE | | | SIGN LOCATION SIGN ON THE CORNER OF 76TH & CICERO AVE.: 18'-3" X 27'-6" LED ILLUMINATED MONUMENT SIGN CABINET "AMC THEATRES" | | | | | |
| TOTAL FEE 200.00 | | | <div style="border: 1px solid black; padding: 5px; display: inline-block;"> <u>Check # for Zoning</u> </div> | | | | | |
| AMOUNT PAID 200.00 | | | | | | | | |
| BALANCE DUE | | | | | | | | |
| | | | <div style="border: 1px solid black; padding: 5px; display: inline-block;"> <u>Check # for DCAP</u> </div> | | | | | |
| | | | | | | | | |

The undersigned certify that the statements in this application are true and correct and that all work done under the proposed permit will conform to the requirements of the Chicago Municipal Code

| | | |
|---|-----------|--|
| REG. NO. E94598 | BOND. NO. | REG. NO. N90650 |
| ELECT CONTR MARTIN G. SCHANER | ELECTR | SIGN ERECTOR SURE LIGHT SERVICE CO |
| ADDRESS 260 KNOX PARK ROAD LAKE ZURICH, IL 60047- | | ADDRESS 1225 BOWES RD ELGIN IL, 60123- |
| SUPERVISOR SIGNATURE | | SIGNATURE |

The permit issued on this application will authorize only signs here applied for. If other signs are to be erected they must be covered by additional permits

City of Chicago
Rahm Emanuel, Mayor



Department of Buildings
Felicia Davls, Commissioner

| | |
|--|--|
| TYPE OF BUSINESS <u>COMMERCIAL</u> Other: <u>THEATRE</u> Name: <u>AMC</u> LIC #: <u>1799064</u> Renewal Date: <u>11/15/2015</u> | SIGN BOND REQUIRED? <input type="checkbox"/> YES COUNCIL ORDER REQUIRED <input checked="" type="checkbox"/> YES IS SPECIAL PERMISSION REQUIRED FROM CHIEF ELECTRICAL <input type="checkbox"/> YES IF YES, ATTACH LETTER OF REQUEST TIME STAMP |
| Projects Over: <input checked="" type="checkbox"/> Private Property <input checked="" type="checkbox"/> Public Way Grant Permit #: _____ <input type="checkbox"/> Planned Development/Manufacturing PMD/PD#: _____ Zoning District: <u>B3</u> Other: _____ | TYPE OF SIGN: <input type="checkbox"/> ADVERTISING <input checked="" type="checkbox"/> ILLUMINATE <input type="checkbox"/> MOVEABLE <input checked="" type="checkbox"/> BUSINESS <input type="checkbox"/> FLASHING |
| TOTAL STREET FRONTAGE OF LOT (IN FEET) <u>600</u> TOTAL AREA OF NEW SIGN (SQ.FT.) <u>502</u> TOTAL AREA OF ALL SIGNS ON LOT (SQ.FT.) <u>1,300</u> HEIGHT OF SIGN ABOVE GRADE (TO TOP) <u>21 ft 3in</u> | SIGN CLERK APPROVED FOR PERMIT |
| DISTANCE OF CURB LINE OUTER EDGE (ft) <u>18</u> DISTANCE OF STRUCTURE INNER EDGE (ft) <u>45</u> | REMARKS |
| DISTANCE FROM (ft): A. PUBLIC PARK (OVER 10 ACRES) <u>1,000</u> B. EXPRESSWAY (IF LESS THAN 1,000 FT.) <u>1,000</u> C. RESIDENCE DISTRICT (ADVERTISING SIGNS ONLY) <u>1,000</u> | |
| IF REPLACEMENT SIGN OR CHANGE OF FACE, WHAT DOES THE EXISTING SIGN READ? Original Payee: _____ | |
| Landmark Hold: <input type="checkbox"/> Status: _____ | |
| ZONING (OFFICE USE ONLY) | |

CITY OF CHICAGO
DEPARTMENT OF ZONING AND LAND USE PLANNING
SIGN SITE PLAN
(ALL INFORMATION MUST BE COMPLETED AND LEGIBLE)

Site Address: 7601 S. Cicero Ave. 2 of 2 applications

Sign Company: Sure Light Sign Company Rep Name: Gayle Miller #2172670

Phone (815) 355 - 9841 EXT N/A *(Below: Building, streets and location of sign on lot or structure)*
 North

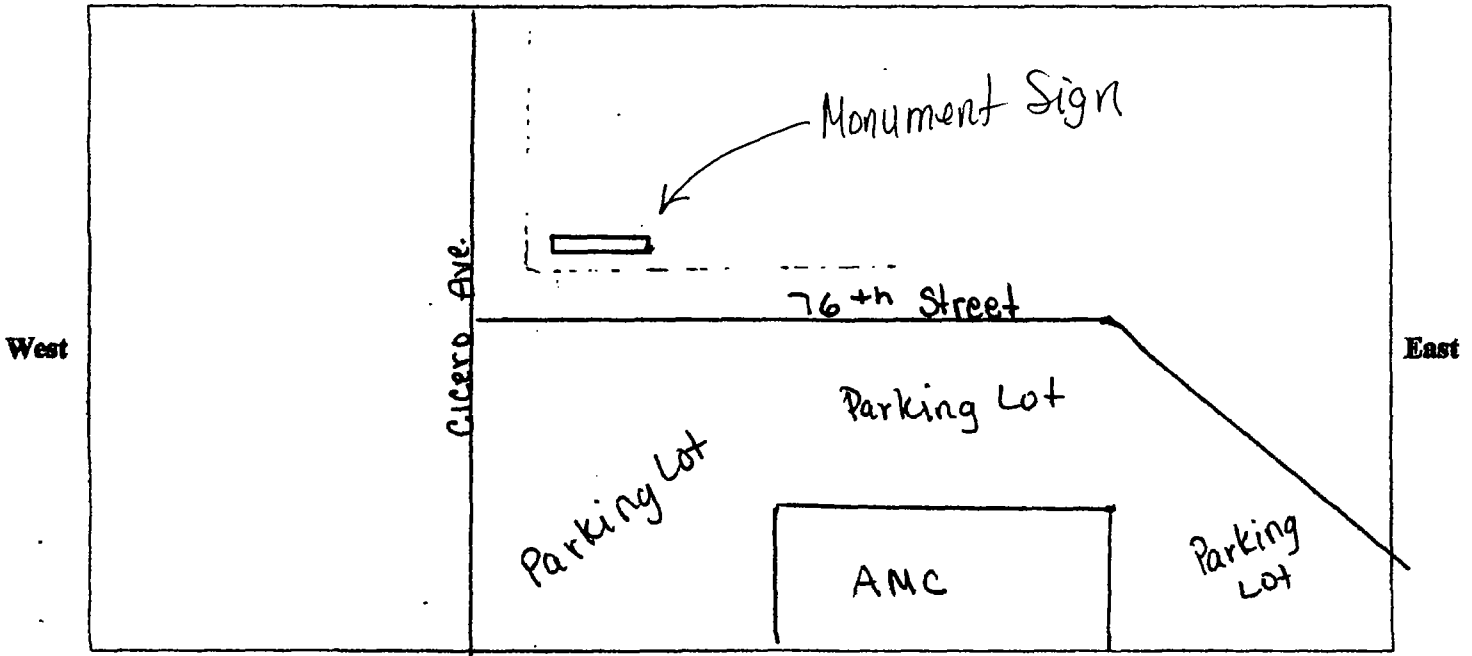

South

SIGN USE:

- Bus. ID (On-premise)
 Business Lice. # 1799064
 Advertising (Off-premise)

TYPE OF SIGN:

- Flat Wall
 Freestanding
 Awning
 Marquee
 High Rise Building
 Projecting Private
 Projecting Public Way
 Public Way Use -Permit # _____

SIGN CHARACTERISTICS:

- Non- Illuminated
 Illuminated
 Changing Image
 Video Display
 Flashing

PERMIT TYPE:

- New Construction
 Change of Face _____
 Previous Permit #

DISTANCE FROM:

- Curb Line: _____
 Expressway, Toll Roads
 or Major Route _____
 (n/a if over 1000 ft) >1000
 Park (over 10 acres) >1000
 Residential Zone >1000
 Existing Off-premise on
 same side of street: N/A

TOTAL SQUARE FOOTAGE:

- Square footage of this proposed sign 502
 Gross area of all proposed signs 780
 Area of all existing signs
 (not including proposed) on Zoning Lot 1300

Signature : _____ #2172670

Date: 4/29/14



City of Chicago



Or2014-226

Office of the City Clerk

Document Tracking Sheet

| | |
|---------------------------------|---|
| Meeting Date: | 5/28/2014 |
| Sponsor(s): | Lane (18) |
| Type: | Order |
| Title: | Issuance of permits for sign(s)/signboard(s) at 7601 S Cicero Ave - 278 sq. ft. |
| Committee(s) Assignment: | Committee on Zoning, Landmarks and Building Standards |

Committee on Zoning, Landmarks, and Building Standards

(Signs)

ORDERED, That the Commissioner of Buildings is hereby directed to issue a sign permit to: (Contractor's name and address)

Sure Light Sign Company

260 Knox Park Road

Lake Zurich, IL 60047

for the erection of a sign/signboard over 24 feet in height and/or over 100 square feet (in area of one face) at: (Business Name & Address)

American Multi-Cinema, Inc. (AMC)

Permit #100537531

7601 S. Cicero Ave.

Chicago, IL 60652

Dimensions: Length 33' - 9" **Height** 8' - 3"

Height above grade/roof to top of sign 20' 3"

TOTAL SQUARE FOOT AREA: 278

Such sign(s) shall comply with all applicable provisions of TITLE 17 of the Chicago Zoning Ordinance and all other applicable provisions of the Municipal Code of the City of Chicago governing the construction and maintenance of outdoor signs, signboards and structures.

Soma Lane, Ward 18th

Alderman Lane

Ward 18

10001001



| | |
|---|--|
| 13-1654 R3 | |
| 2 of 6 | |
| AMC Ford City 14 | |
| 7601 S Chicago Ave Chicago, IL 60652 | |
| Art. No.: Drawing: Design: Date: | Sign Medium: Jualth Burrows G. Gualteruzzi 12/18/13 |
| Client: | |
| Contract: | |
| Location: | |
| Project: | |
| Notes: | |

Channel Signage
 2215 So. State St. Ste. 200
 Chicago, IL 60616
 Tel: 773.442.1100
 Fax: 773.442.1101
 www.amc-signage.com

Channel Signage
 2215 So. State St. Ste. 200
 Chicago, IL 60616
 Tel: 773.442.1100
 Fax: 773.442.1101
 www.amc-signage.com

FINAL ELECTRICAL CONNECTION BY CUSTOMER

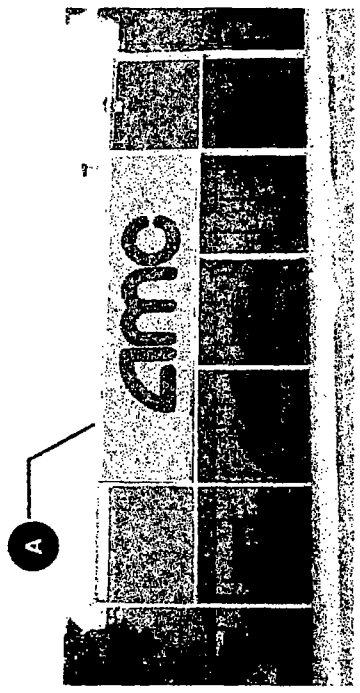

PHOTO SURVEY - AFTER NTS

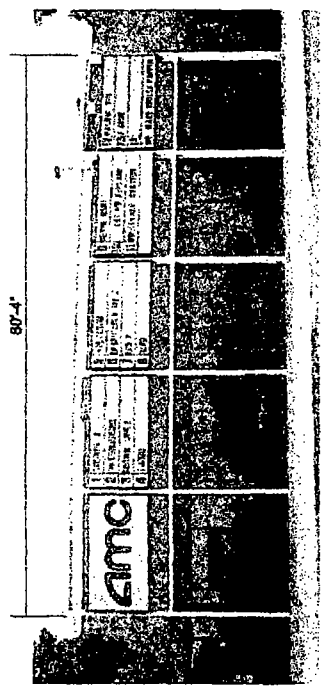
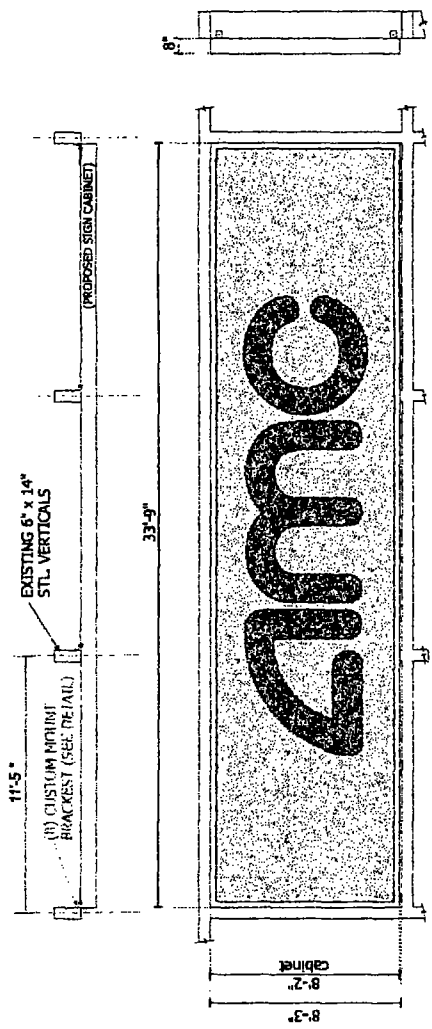
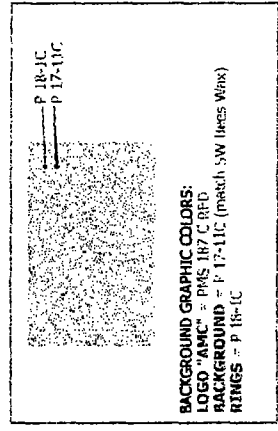
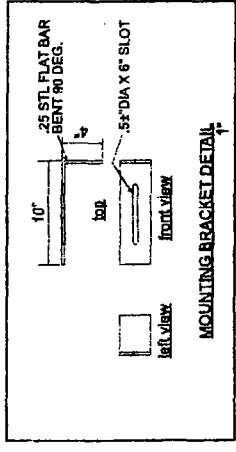

PHOTO SURVEY - BEFORE NTS



REMOVE FIVE EXISTING SIGN CABINETS AND REPLACE WITH ONE LARGE ILLUMINATED SIGN CABINET.
 ALUMINUM FABRICATED CABINET. FILLER/4" RETAINERS PAINTED WHITE.
 INTERNALLY ILLUMINATED WITH WHITE LEDS.
 FLEX-FACE WITH GRAPHICS PRINTED DIRECTLY TO FLEX.
 MOUNT SIGN TO EXISTING STEEL FRAME USING STEEL BRACKETS PTD. WHITE.
 FINAL ARTWORK PRINT TO BE PROVIDED BY CLIENT (DD).

S/F Sign Detail
 SCALE: 3/16" = 1'-0"
 ONE (1) REQUIRED - MANUFACTURE AND INSTALL

SQ. FT. 275.63



13-1554 R3
 Sheet 3 of 6
 AMC Field City 14

7601 S Chicago Ave
 Chicago, IL 60632

Art. No. Stan Marston
 Customer: Justin Barabino
 Designer: G. Guibertre
 Date: 12/18/13

Client: _____
 Make: _____
 City: _____
 State: _____
 License: _____
 Engineer: _____

NOT TO SCALE. THIS IS AN ESTIMATE OF THE LED LAYOUT. THE ACTUAL LAYOUT WILL BE DETERMINED BY THE LED MANUFACTURER. ALL DIMENSIONS ARE APPROXIMATE. © 2013 AMC SIGNAGE SYSTEMS, INC.

Chandler Signs
 1234 S. State St. Suite 100
 Chicago, IL 60605
 Tel: 773-444-1234
 Fax: 773-444-5678
 Email: info@chandler-signs.com
 Website: www.chandler-signs.com

FINAL ELECTRICAL CONNECTION BY CUSTOMER

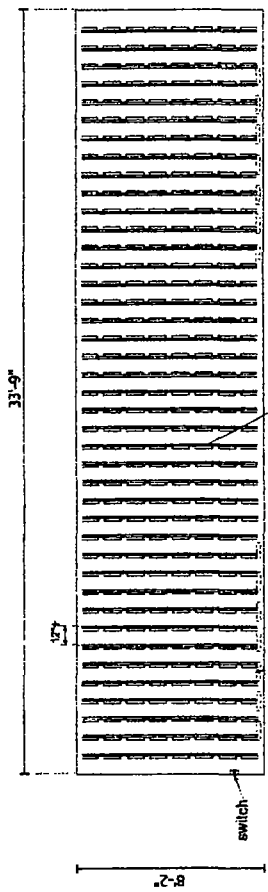

A S/F Sign - Lighting Detail SCALE: 3/16" = 1'-0"

Copy for Ald. Lane



CITY OF CHICAGO DEPARTMENT OF BUILDINGS

Sign Permit Application

| | | | | |
|---|--|--|------------------------------|--|
| APPROVAL NUMBER | APPLICATION NUMBER 100537531 | ANNUAL FEE | WORK CODE | DRAWINGS ATTACHED <input type="checkbox"/> YES <input type="checkbox"/> NO |
| DATE OF APPLICATION 04/24/2014 | ADDRESS OF SIGN 7601 S CICERO AVE, 60652- | | TYPE OF SIGN FLAT OR BOX | |
| BUILDING | ORIGINAL PERMIT NUMBER | LENGTH 33 | FT 9 | HEIGHT 8 |
| TYPE OF PERMIT NEW CONSTRUCTION (SIGN) | | AREA 278 | SQ. FT. | WEIGHT 900 |
| PAYER OF ANNUAL INSPECTION AMC, 4440 W. 77TH ST., FLOOR 1 CHICAGO, IL 60652 (773)555-5555 | | SIGN HEIGHT ABOVE GRADE/ROOF 12 | | IN 3 |
| SIGN MANUFACTURER CHANDLER SIGNS | | SHAPE OF SIGN REGULAR | | |
| ADDRESS WHERE SIGN CAN BE SEEN PRIOR TO ERECTION | | SIGN WILL READ AMC | | |
| TICKET NUMBER 0 | REINSPECTION CONTROL NUMBER | NO. OF LAMPS 328 | TOTAL WATTAGE 1020 | |
| TYPE OF SUPPORT FOR SIGN BUILDING | | TYPE OF LAMP OTHER | | |
| SIGN BOARD SUPPORT MEMBERS STEEL | | NO. OF BALLAST/TRANSFORMERS 14 | INPUT OF TRANSFORMERS 120 | |
| ANNUAL FEE | | CONTRACTOR WILL INSTALL <input checked="" type="checkbox"/> FEEDERS <input type="checkbox"/> CUSTOMER LEADS <input type="checkbox"/> | | |
| CONSTRUCTION FEE 700.00 | | TYPE OF SWITCH SPECIAL | | |
| 1017 B FEE | | LOCATION OF SWITCH OUTSIDE SIGN | | |
| TOTAL FEE 700.00 | | SIGN LOCATION NORTH ELEVATION: 8'-3" X 33'-9" LED ILLUMINATED WALL SIGN CABINET "AMC" - SIGN IS ON PRIVATE PROPERTY. | | |
| AMOUNT PAID 200.00 | | | | |
| BALANCE DUE \$ 500.00 | | | | |

The undersigned certify that the statements in this application are true and correct and that all work done under the proposed permit will conform to the requirements of the Chicago Municipal Code

| | |
|----------------------|--|
| REG NO. | E94598 |
| ELECT CONTR | MARTIN G. SCHANER |
| ADDRESS | 260 KNOX PARK ROAD LAKE ZURICH, IL 60047- |
| SUPERVISOR SIGNATURE | <i>[Signature]</i> |

| | | |
|-----------|-----------------------------------|--------------------|
| BOND NO. | REG. NO. | N90650 |
| SIGNER | SURE LIGHT SERVICE CO | SIGNER |
| ADDRESS | 1725 BOWES RD ELGIN IL, 60123- | <i>[Signature]</i> |
| SIGNATURE | | |

The permit issued on this application will authorize only signs here applied for. If other signs are to be erected they must be covered by additional permits

City of Chicago
Rahm Emanuel, Mayor



Department of Buildings
Felicia Davis, Commissioner

| | |
|--|--|
| TYPE OF BUSINESS <u>COMMERCIAL</u> Other: <u>THEATRES</u> Name: <u>AMC</u> LIC #: <u>1799064</u> Renewal Date: <u>11/15/2015</u> | SIGN BOND REQUIRED? <input type="checkbox"/> YES COUNCIL ORDER REQUIRED <input checked="" type="checkbox"/> YES IS SPECIAL PERMISSION REQUIRED FROM CHIEF ELECTRICAL <input type="checkbox"/> YES IF YES, ATTACH LETTER OF REQUEST TIME STAMP |
| Projects Over: <input checked="" type="checkbox"/> Private Property <input checked="" type="checkbox"/> Public Way Grant Permit #: _____ <input type="checkbox"/> Planned Development/Manufacturing PMD/PD#: _____ Zoning District: <u>B3</u> Other: _____ | TYPE OF SIGN: <input type="checkbox"/> ADVERTISING <input checked="" type="checkbox"/> ILLUMINATE <input type="checkbox"/> MOVEABLE <input checked="" type="checkbox"/> BUSINESS <input type="checkbox"/> FLASHING |
| TOTAL STREET FRONTAGE OF LOT (IN FEET) <u>600</u> TOTAL AREA OF NEW SIGN (SQ.FT.) <u>278</u> TOTAL AREA OF ALL SIGNS ON LOT (SQ.FT.) <u>1,300</u> HEIGHT OF SIGN ABOVE GRADE (TO TOP) <u>20ft 3in</u> | SIGN CLERK APPROVED FOR PERMIT |
| DISTANCE OF CURB LINE OUTER EDGE (ft) <u>150</u> DISTANCE OF STRUCTURE INNER EDGE (ft) <u>150</u> DISTANCE FROM (ft): A. PUBLIC PARK (OVER 10 ACRES) <u>1,000</u> B. EXPRESSWAY (IF LESS THAN 1,000 FT.) <u>1,000</u> C. RESIDENCE DISTRICT (ADVERTISING SIGNS ONLY) <u>1,000</u> | REMARKS |
| IF REPLACEMENT SIGN OR CHANGE OF FACE, WHAT DOES THE EXISTING SIGN READ? Original Payee: _____ Landmark Hold: <input type="checkbox"/> Status: _____ | |
| ZONING (OFFICE USE ONLY) | |

CITY OF CHICAGO
DEPARTMENT OF ZONING AND LAND USE PLANNING
SIGN SITE PLAN
(ALL INFORMATION MUST BE COMPLETED AND LEGIBLE)

Site Address: 7601 S. Cicero Ave. 1 of 2 applications

Sign Company: Sure Light Sign Company Rep Name: Gayle Miller #2172670

Phone (815) 355 - 9841 EXT N/A (Below: Building, streets and location of sign on lot or structure)
 North

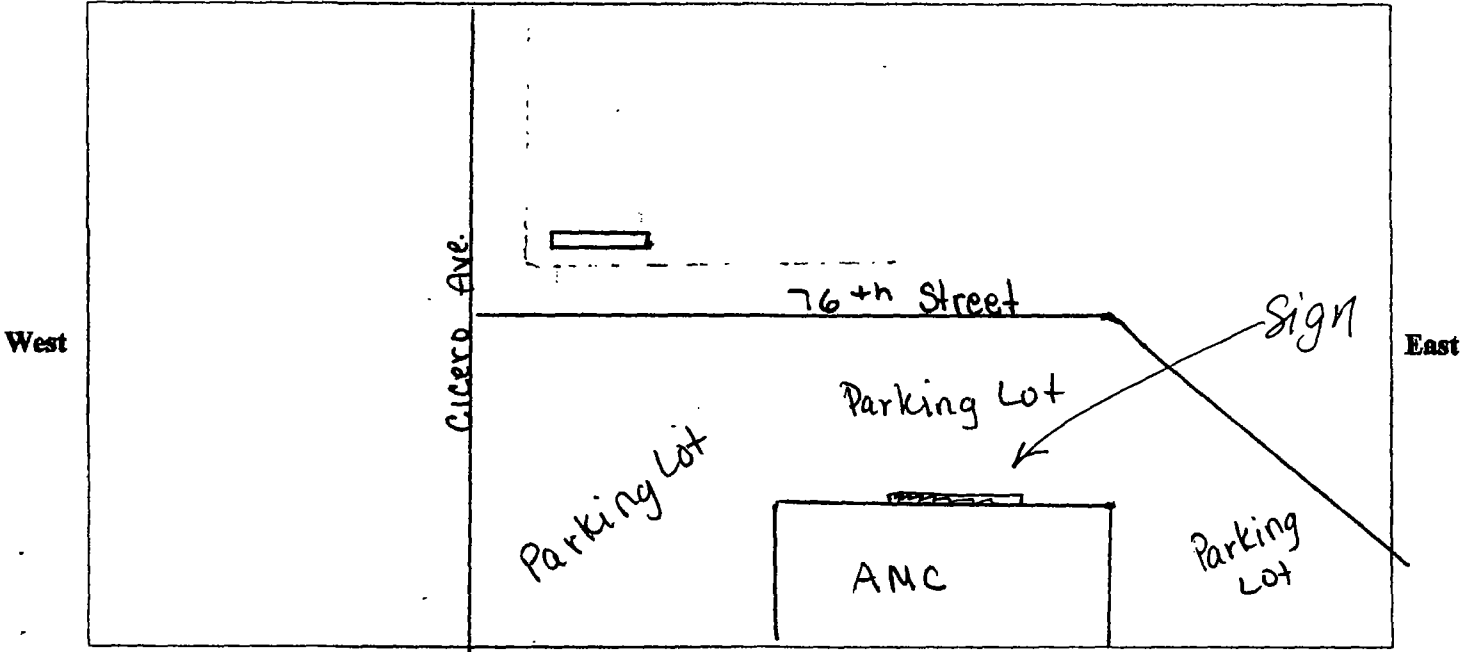

SIGN USE:

Bus. ID (On-premise)

Business Lice. #
1799064

Advertising (Off-premise)

PERMIT TYPE:

New Construction

Change of Face

Previous Permit #

TYPE OF SIGN:

Flat Wall

Freestanding

Awning

Marquee

High Rise Building

Projecting Private

Projecting Public Way

Public Way Use -Permit #

SIGN CHARACTERISTICS:

Non- Illuminated

Illuminated

Changing Image

Video Display

Flashing

DISTANCE FROM:

Curb Line: _____

Expressway, Toll Roads
 or Major Route

(n/a if over 1000 ft) >1000

Park (over 10 acres) >1000

Residential Zone >1000

Existing Off-premise on
 same side of street: N/A

TOTAL SQUARE FOOTAGE:

Square footage of this proposed sign 278

Gross area of all proposed signs 780

Area of all existing signs
 (not including proposed) on Zoning Lot 1300

Signature : _____ #2172670

Date: 4/29/14



City of Chicago

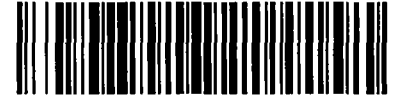

Or2014-231

Office of the City Clerk

Document Tracking Sheet

| | |
|---------------------------------|---|
| Meeting Date: | 5/28/2014 |
| Sponsor(s): | Solis (25) |
| Type: | Order |
| Title: | Issuance of permits for sign(s)/signboard(s) at 1100 S Canal St - sign C1 |
| Committee(s) Assignment: | Committee on Zoning, Landmarks and Building Standards |

Committee on Zoning, Landmarks
and Building Standards
City Council Meeting, May 28, 2014
Alderman Danny Solis, 25th Ward
Sign Orders

ORDERED, That the Commissioner of Buildings is hereby directed to issues sign permits to:

Olympic Signs, Inc.
1130 N. Garfield
Lombard, IL 60148

For the erection of a sign over 24 feet above ground at:

1100 S. Canal Street
Chicago, IL 60607

Dimensions: length 18'-0" height 5'-2"

Height above grade/roof to top of sign 54'-6"

Total Square Foot Area 93 Square Feet

Such sign shall comply with all applicable provisions of TITLE 17 of the Chicago Zoning Ordinance and all other applicable provisions of the Municipal Code of the City of Chicago governing the construction and maintenance of outdoor signs, signboards and structures.

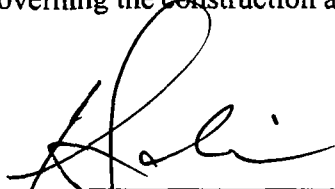

Danny Solis, Alderman, 25th Ward

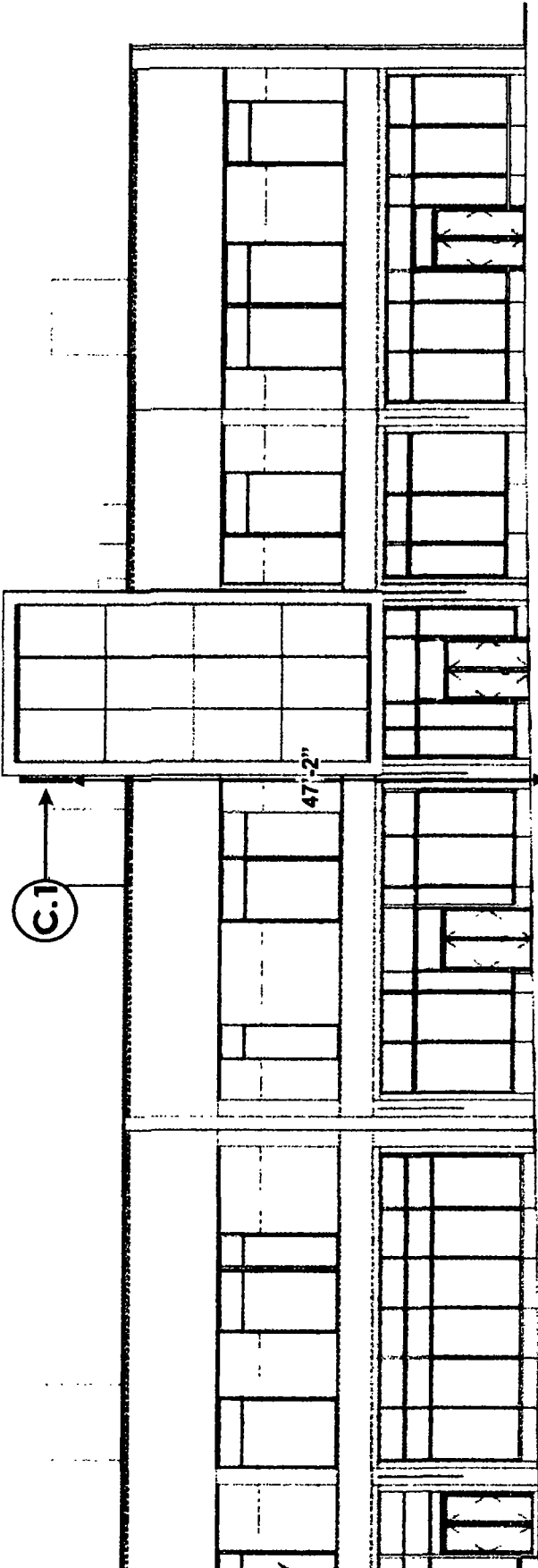

SIGN TYPES: C.1 / PARTIAL EAST ELEVATION

SCALE: 1/16" = 1'-0"

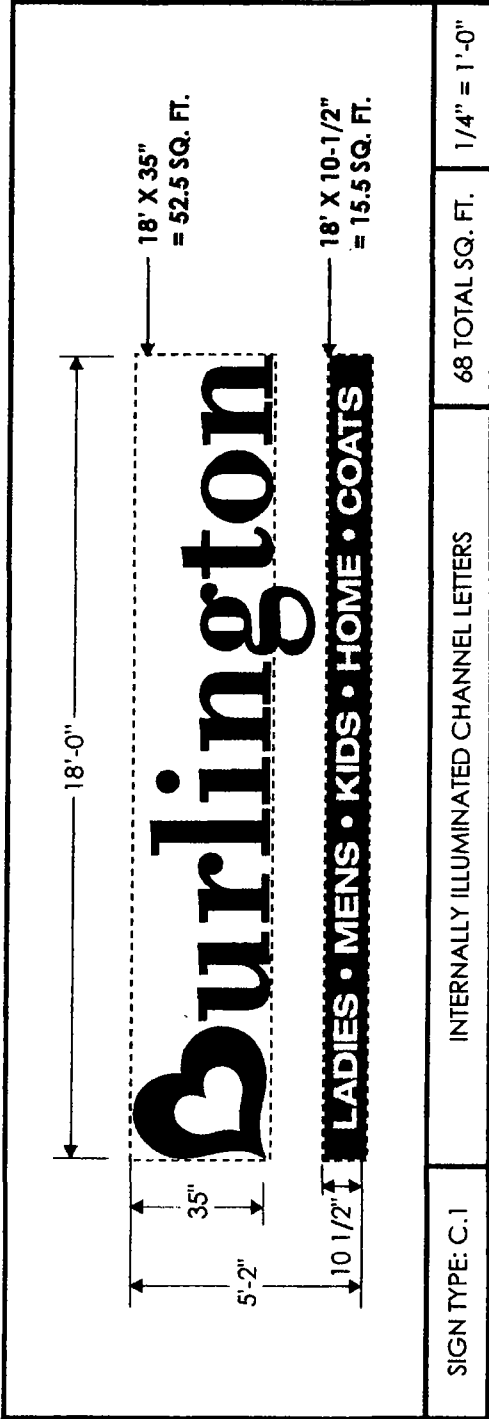

SIGN TYPE: C.1 INTERNALLY ILLUMINATED CHANNEL LETTERS 68 TOTAL SQ. FT. 1/4" = 1'-0"

| | | | | | | |
|--|--|--|-------------------|--|---|------------------------|
|  BLAIR SIGN PROGRAMS | Northern California: (510) 337-9020 Southern California: (619) 792-1600 | 9932 Prospect Ave Studio 137 San Jose, CA 92071 blair@blairsign.net CA License #677503 | Burlington | CLIENT: Burlington PROJECT: Chicago, IL (The Murrell) ADDRESS: 1100 South Canal St. Ste. 201 Chicago, IL 60607 | STARTING DATE: 05/12/2014 BY: K. Bower REVISIONS: | Section I Sheet # 4 |
| | © 2014 BLAIR SIGN PROGRAMS | | | | | |





City of Chicago



Or2014-232

Office of the City Clerk

Document Tracking Sheet

| | |
|---------------------------------|---|
| Meeting Date: | 5/28/2014 |
| Sponsor(s): | Solis (25) |
| Type: | Order |
| Title: | Issuance of permits for sign(s)/signboard(s) at 1100 S Canal St - sign C2 |
| Committee(s) Assignment: | Committee on Zoning, Landmarks and Building Standards |

Committee on Zoning, Landmarks
and Building Standards
City Council Meeting, May 28, 2014
Alderman Danny Solis, 25th Ward
Sign Orders

ORDERED, That the Commissioner of Buildings is hereby directed to issues sign permits to:

Olympic Signs, Inc.
1130 N. Garfield
Lombard, IL 60148

For the erection of a sign over 24 feet above ground at:

1100 S. Canal Street
Chicago, IL 60607

Dimensions: length 18'-0" height 5'-2"

Height above grade/roof to top of sign 54'-6" above grade

Total Square Foot Area 93 Square Feet

Such sign shall comply with all applicable provisions of TITLE 17 of the Chicago Zoning Ordinance and all other applicable provisions of the Municipal Code of the City of Chicago governing the construction and maintenance of outdoor signs, signboards and structures.

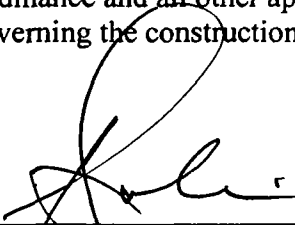

Danny Solis, Alderman, 25th Ward

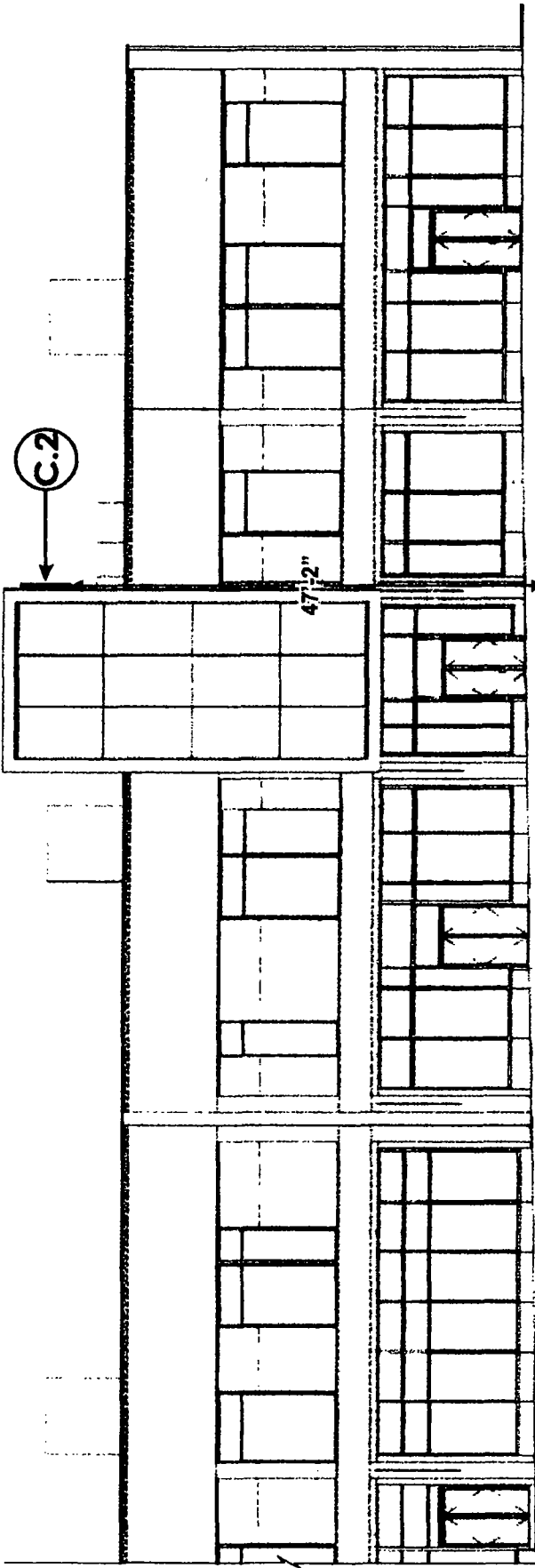

SCALE: 1/16" = 1'-0"

SIGN TYPES: C.2 / PARTIAL EAST ELEVATION

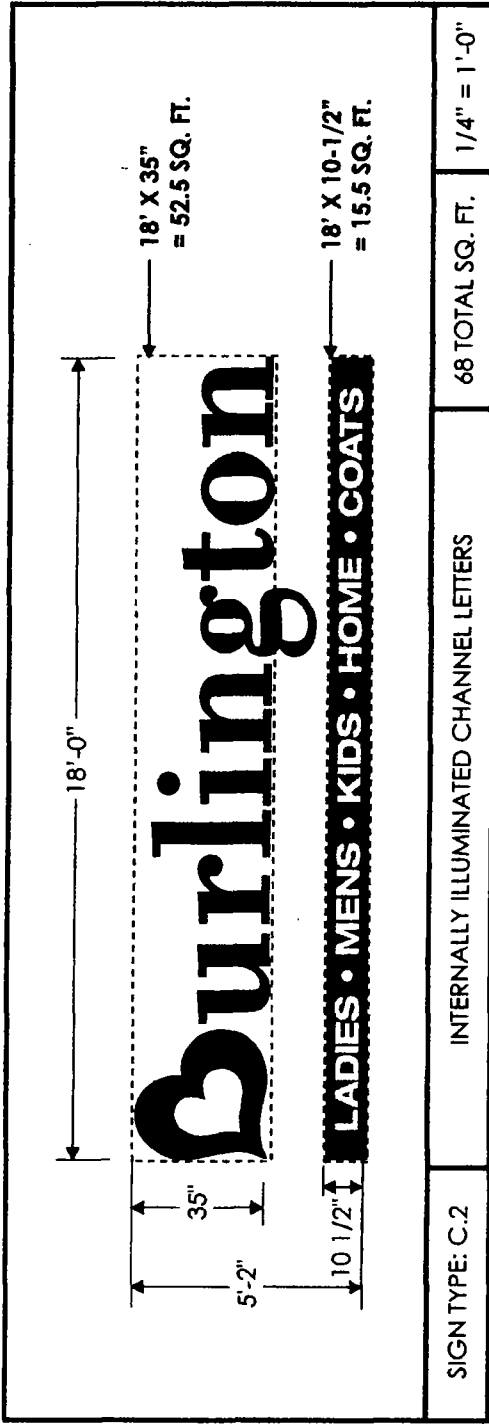

68 TOTAL SQ. FT. 1/4" = 1'-0"

INTERNALLY ILLUMINATED CHANNEL LETTERS

SIGN TYPE: C.2

Section I
Sheet # 5
© 2014 BLAIR SIGN PROGRAMS

STARTING DATE: 05/12/2014
BY: K. Bower
REVISIONS:

CLIENT: Burlington
PROJECT: Chicago, IL (The Maxwell)
ADDRESS: 1100 South Canal St. Ste. 201
Chicago, IL 60607

Burlington

9932 Prospect Ave
Studio 137
San Jose, CA 92071
blair@blairsign.net
CA License #677503

Northern California:
(510) 337-9020
Southern California:
(619) 792-1600

BLAIR SIGN PROGRAMS

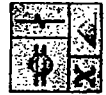



City of Chicago



Or2014-233

Office of the City Clerk

Document Tracking Sheet

| | |
|---------------------------------|---|
| Meeting Date: | 5/28/2014 |
| Sponsor(s): | Solis (25) |
| Type: | Order |
| Title: | Issuance of permits for sign(s)/signboard(s) at 1100 S Canal St - sign C3 |
| Committee(s) Assignment: | Committee on Zoning, Landmarks and Building Standards |

Committee on Zoning, Landmarks
and Building Standards
City Council Meeting, May 28, 2014
Alderman Danny Solis, 25th Ward
Sign Orders

ORDERED, That the Commissioner of Buildings is hereby directed to issues sign permits to:

Olympic Signs, Inc.
1130 N. Garfield
Lombard, IL 60148

For the erection of a sign over 24 feet above ground at:

1100 S. Canal Street
Chicago, IL 60607

Dimensions: length 18'-0" height 5'-2"

Height above grade/roof to top of sign 35'-4" above grade

Total Square Foot Area 93 Square Feet

Such sign shall comply with all applicable provisions of TITLE 17 of the Chicago Zoning Ordinance and all other applicable provisions of the Municipal Code of the City of Chicago governing the construction and maintenance of outdoor signs, signboards and structures.

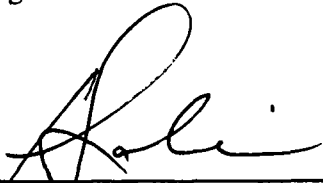

Danny Solis, Alderman, 25th Ward

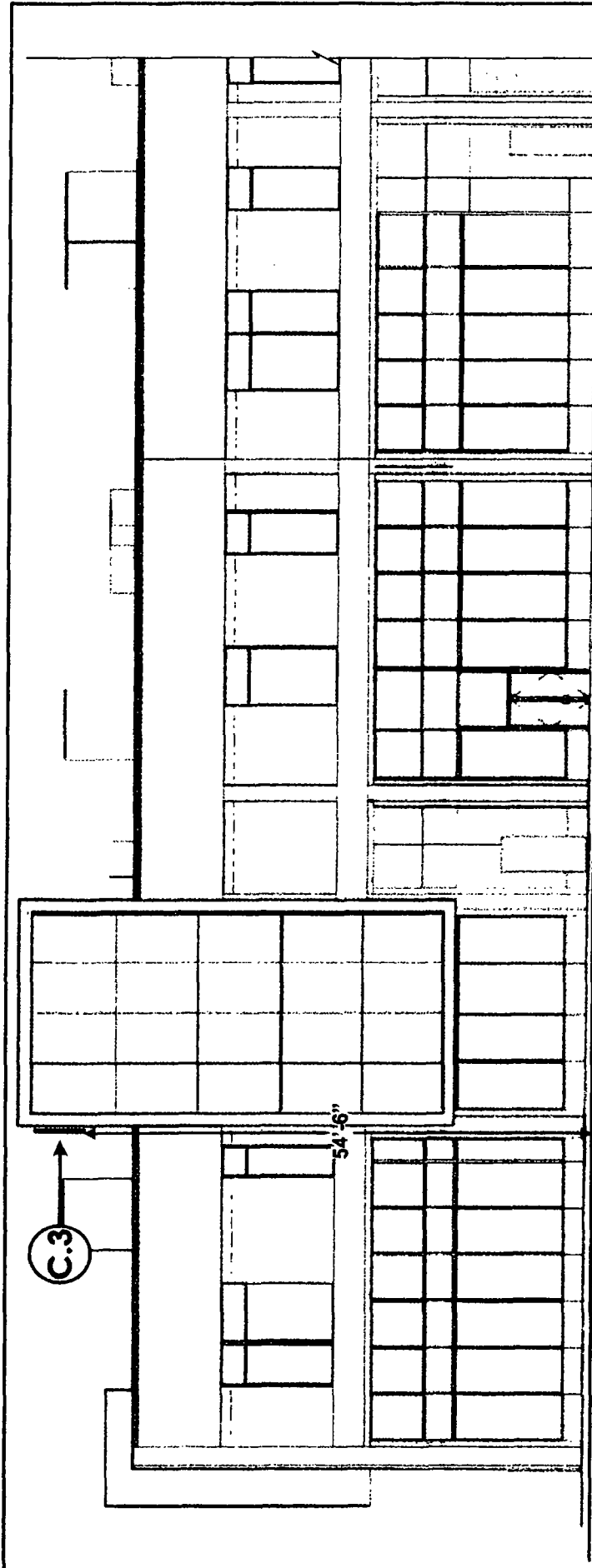

SIGN TYPES: C:3 / PARTIAL WEST ELEVATION

SCALE: 1/16" = 1'-0"

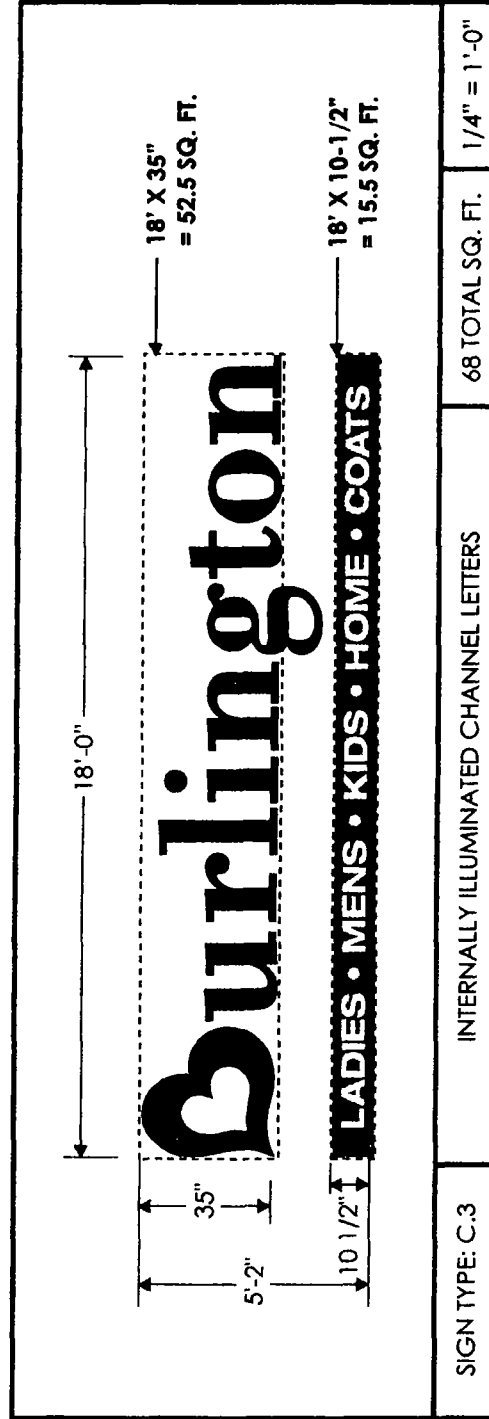

| | | | | | |
|---|---|--------------------------|--|--|---|
|  <p>BLAIR SIGN PROGRAMS</p> | <p>Northern California: (510) 337-9020 Southern California: (619) 792-1600</p> <p>9932 Prospect Ave Studio 137 San Jose CA 92071 blair@blairsign.net CA License #677503</p> | <p>Burlington</p> | <p>CLIENT: Burlington PROJECT: Chicago, IL (The Market) ADDRESS: 1100 South Canal St. Ste. 201 Chicago, IL 60607</p> | <p>STARTING DATE: 05/12/2014 BY: K. Bower REVISIONS:</p> | <p>Section I Sheet # 6 © 2014 BLAIR SIGN PROGRAMS</p> |
|---|---|--------------------------|--|--|---|



City of Chicago



Or2014-234

Office of the City Clerk

Document Tracking Sheet

| | |
|---------------------------------|---|
| Meeting Date: | 5/28/2014 |
| Sponsor(s): | Solis (25) |
| Type: | Order |
| Title: | Issuance of permits for sign(s)/signboard(s) at 1100 S Canal St - sign C4 |
| Committee(s) Assignment: | Committee on Zoning, Landmarks and Building Standards |

Committee on Zoning, Landmarks
and Building Standards
City Council Meeting, May 28, 2014
Alderman Danny Solis, 25th Ward
Sign Orders

ORDERED, That the Commissioner of Buildings is hereby directed to issues sign permits to:

Olympic Signs, Inc.
1130 N. Garfield
Lombard, IL 60148

For the erection of a sign over 24 feet above ground at:

1100 S. Canal Street
Chicago, IL 60607

Dimensions: length 18'-0" height 5'-2"

Height above grade/roof to top of sign 47'-2" above grade;

Total Square Foot Area 93 Square Feet

Such sign shall comply with all applicable provisions of TITLE 17 of the Chicago Zoning Ordinance and all other applicable provisions of the Municipal Code of the City of Chicago governing the construction and maintenance of outdoor signs, signboards and structures.

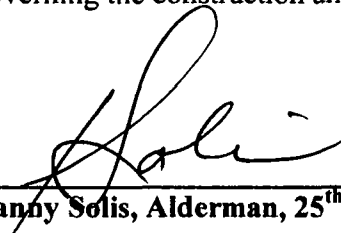

Danny Solis, Alderman, 25th Ward

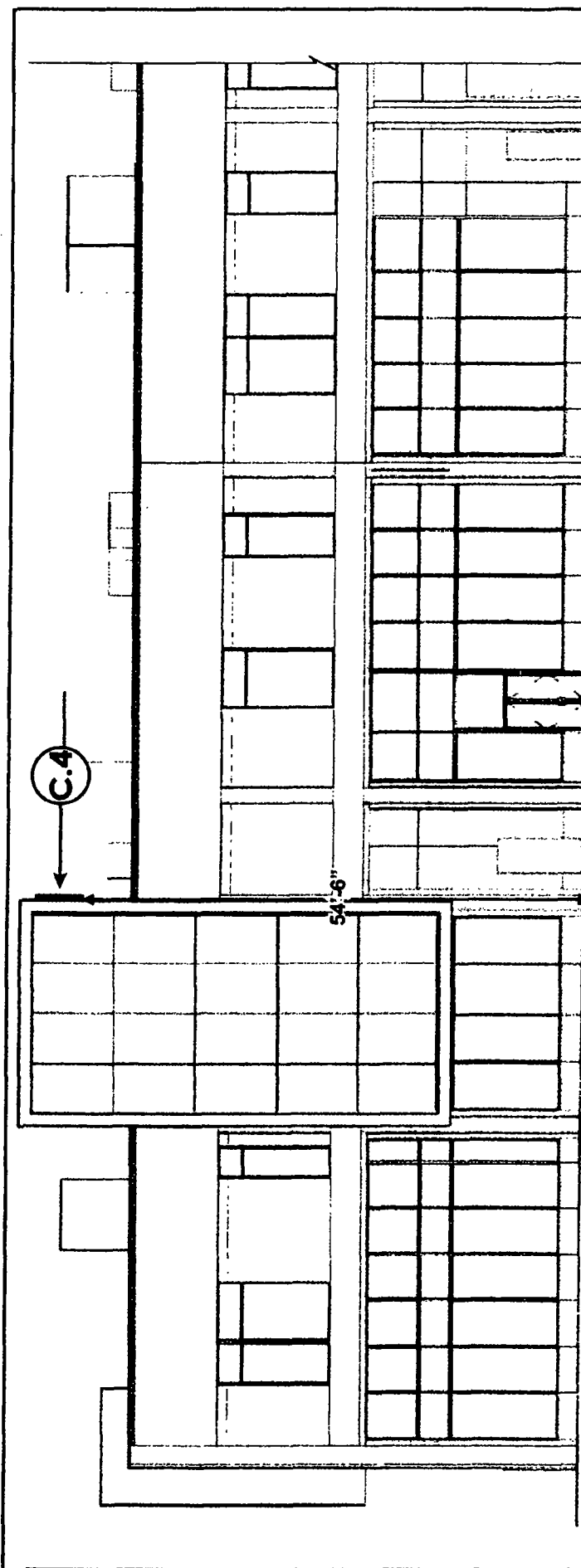

SIGN TYPES: C.4 / PARTIAL WEST ELEVATION

SCALE: 1/16" = 1'-0"

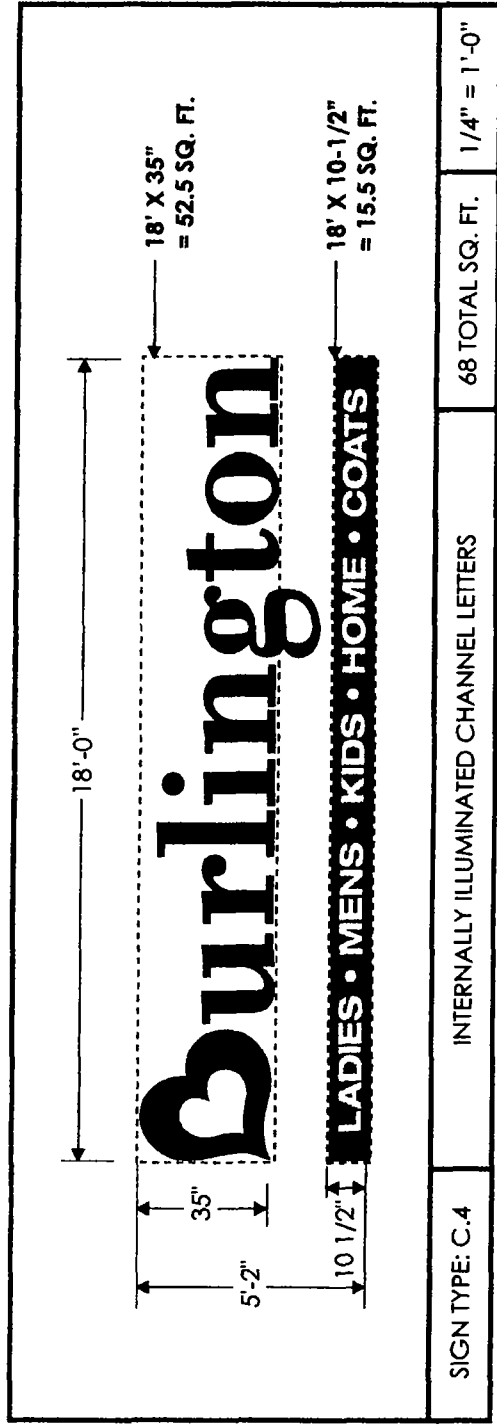

SIGN TYPE: C.4

INTERNALLY ILLUMINATED CHANNEL LETTERS

68 TOTAL SQ. FT.

1/4" = 1'-0"

Northern California:
 (510) 337-9020
 Southern California:
 (619) 792-1400

BLAIR SIGN PROGRAMS

9932 Prospect Ave
 Studio 137
 SanTEE, CA 92071
 blair@blairsign.net
 CA License #877503

Burlington

CLIENT: Burlington
 PROJECT: Chicago, IL (The Maxwell)
 ADDRESS: 1100 South Canal St. Ste. 201
 Chicago, IL 60607

STARTING DATE: 05/12/2014
 BY: K. Bowert
 REVISIONS:

Section I
 Sheet # 7



City of Chicago

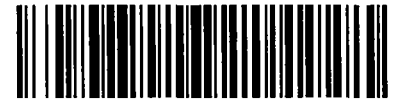

Or2014-235

Office of the City Clerk

Document Tracking Sheet

| | |
|---------------------------------|---|
| Meeting Date: | 5/28/2014 |
| Sponsor(s): | Solis (25) |
| Type: | Order |
| Title: | Issuance of permits for sign(s)/signboard(s) at 1100 S Canal St - sign C5 |
| Committee(s) Assignment: | Committee on Zoning, Landmarks and Building Standards |

Committee on Zoning, Landmarks
and Building Standards
City Council Meeting, May 28, 2014
Alderman Danny Solis, 25th Ward
Sign Orders

ORDERED, That the Commissioner of Buildings is hereby directed to issues sign permits to:

Olympic Signs, Inc.
1130 N. Garfield
Lombard, IL 60148

For the erection of a sign over 24 feet above ground at:

1100 S. Canal Street
Chicago, IL 60607

Dimensions: length 18'-0" height 5'-2"

Height above grade/roof to top of sign 47'-2" above grade

Total Square Foot Area 93 Square Feet

Such sign shall comply with all applicable provisions of TITLE 17 of the Chicago Zoning Ordinance and all other applicable provisions of the Municipal Code of the City of Chicago governing the construction and maintenance of outdoor signs, signboards and structures.

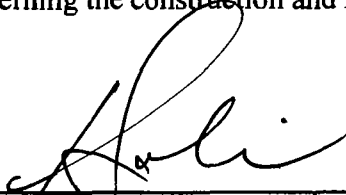

Danny Solis, Alderman, 25th Ward

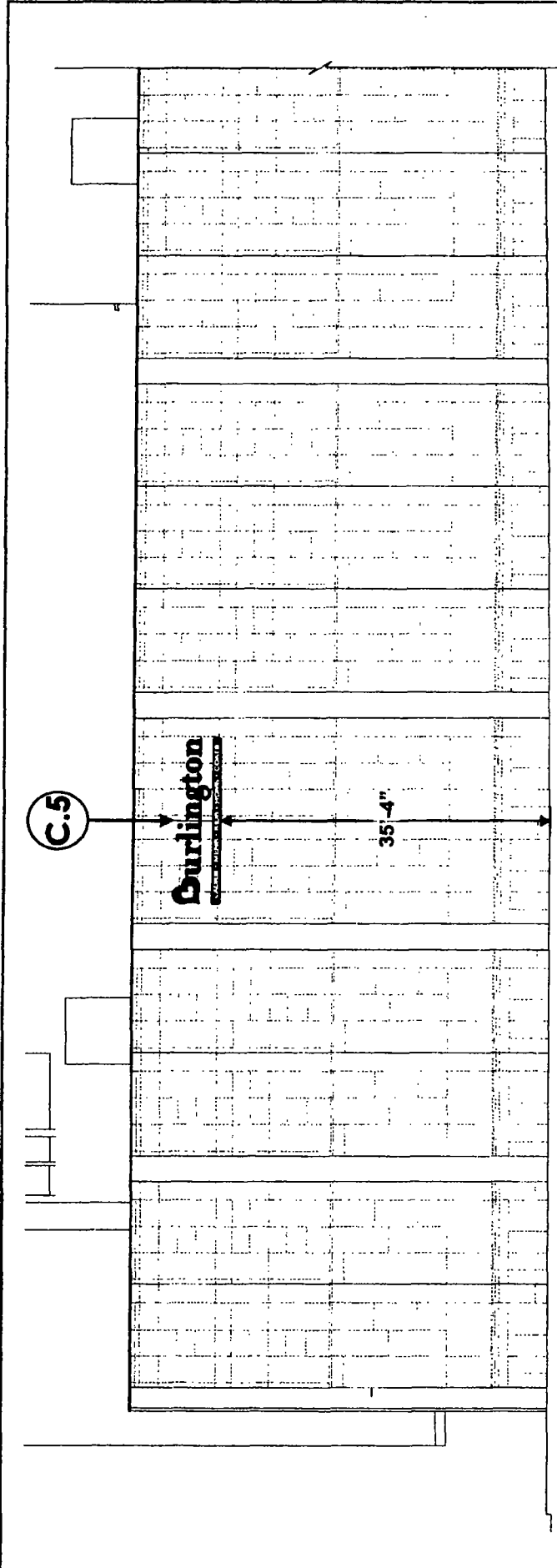

SIGN TYPES: C.5 / PARTIAL SOUTH ELEVATION

SCALE: 1/16" = 1'-0"

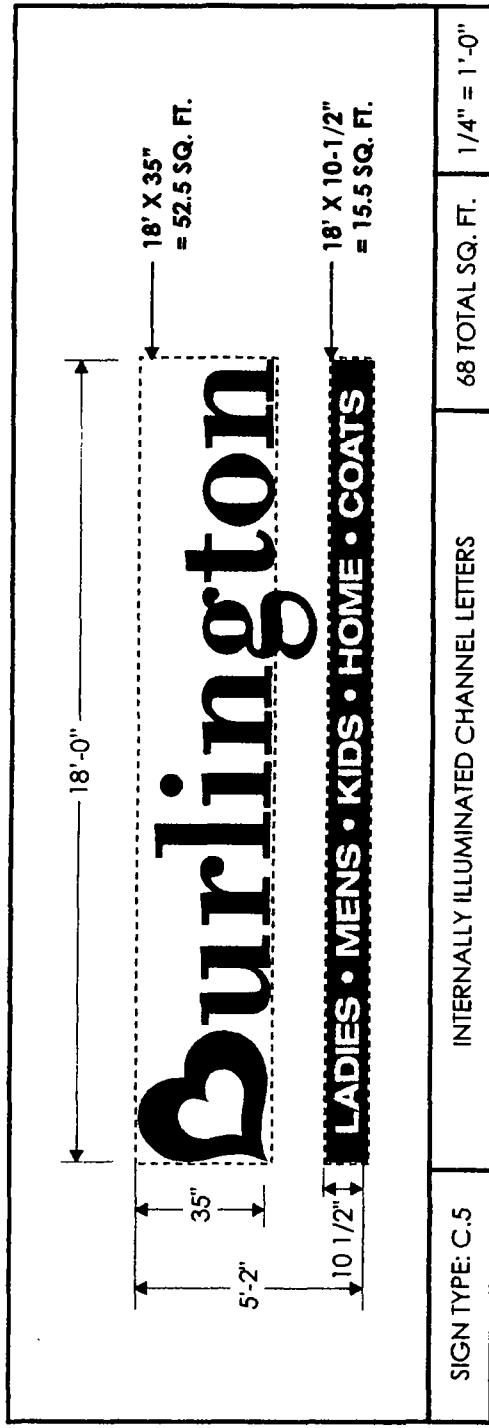

BLAIR SIGN PROGRAMS

Northern California: 9932 Prospect Ave Studio 137
 (510) 337-9020 Santee, CA 92071
 Southern California: blair@blairsign.net
 (619) 792-1600 CA License #877503

Burlington

CLIENT: Burlington
 PROJECT: Chicago, IL (The Maxwell)
 ADDRESS: 100 South Canal St. Ste. 201
 Chicago, IL 60607

STARTING DATE: 05/12/2014
 BY: K. Roseett
 REVISIONS:

Section I
 Sheet # 8



City of Chicago

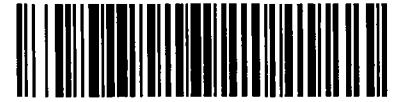

Or2014-236

Office of the City Clerk

Document Tracking Sheet

| | |
|---------------------------------|--|
| Meeting Date: | 5/28/2014 |
| Sponsor(s): | Solis (25) |
| Type: | Order |
| Title: | Issuance of permits for sign(s)/signboard(s) at 1100 S Canal St - 137 sq. ft. Sign 1 |
| Committee(s) Assignment: | Committee on Zoning, Landmarks and Building Standards |

Committee on Zoning, Landmarks
and Building Standards
City Council Meeting, May 28, 2014
Alderman Danny Solis, 25th Ward
Sign Order

ORDERED, That the Commissioner of Buildings is hereby directed to issues sign permits to:

Blair Sign Programs
9935 Prospect Avenue, Studio 137
Santee, CA 92071

For the erection of a sign over 100 square feet (in area of one face) and over 24 feet above ground at:

1100 S. Canal Street
Chicago, IL 60607

Dimensions: length 17'-2" height 8'-0"

Height above grade/roof to top of sign 38' above grade

Total Square Foot Area 137 Square Feet

Such sign shall comply with all applicable provisions of TITLE 17 of the Chicago Zoning Ordinance and all other applicable provisions of the Municipal Code of the City of Chicago governing the construction and maintenance of outdoor signs, signboards and structures.

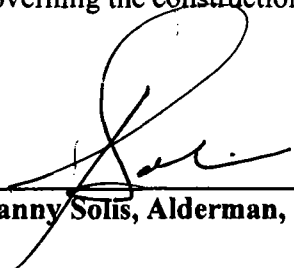

Danny Solis, Alderman, 25th Ward



City of Chicago



Or2014-237

Office of the City Clerk

Document Tracking Sheet

| | |
|---------------------------------|--|
| Meeting Date: | 5/28/2014 |
| Sponsor(s): | Solis (25) |
| Type: | Order |
| Title: | Issuance of permits for sign(s)/signboard(s) at 1100 S Canal St - 137 sq. ft. Sign 2 |
| Committee(s) Assignment: | Committee on Zoning, Landmarks and Building Standards |

Committee on Zoning, Landmarks
and Building Standards
City Council Meeting, May 28, 2014
Alderman Danny Solis, 25th Ward
Sign Order

ORDERED, That the Commissioner of Buildings is hereby directed to issues sign permits to:

Blair Sign Programs
9935 Prospect Avenue, Studio 137
Santee, CA 92071

For the erection of a sign over 100 square feet (in area of one face) and over 24 feet above ground at:

1100 S. Canal Street
Chicago, IL 60607

Dimensions: length 17'-2" height 8'-0"

Height above grade/roof to top of sign 38' above grade

Total Square Foot Area 137 Square Feet

Such sign shall comply with all applicable provisions of TITLE 17 of the Chicago Zoning Ordinance and all other applicable provisions of the Municipal Code of the City of Chicago governing the construction and maintenance of outdoor signs, signboards and structures.

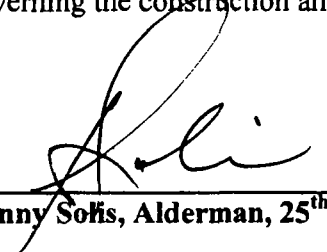

Danny Solis, Alderman, 25th Ward



City of Chicago



Or2014-238

Office of the City Clerk

Document Tracking Sheet

| | |
|---------------------------------|--|
| Meeting Date: | 5/28/2014 |
| Sponsor(s): | Solis (25) |
| Type: | Order |
| Title: | Issuance of permits for sign(s)/signboard(s) at 1100 S Canal St - 137 sq. ft - Sign B1 |
| Committee(s) Assignment: | Committee on Zoning, Landmarks and Building Standards |

Committee on Zoning, Landmarks
and Building Standards
City Council Meeting, May 28, 2014
Alderman Danny Solis, 25th Ward
Sign Order

ORDERED, That the Commissioner of Buildings is hereby directed to issues sign permits to:

Blair Sign Programs
9935 Prospect Avenue, Studio 137
Santee, CA 92071

For the erection of a sign over 100 square feet (in area of one face) and over 24 feet above ground at:

1100 S. Canal Street
Chicago, IL 60607

Dimensions: length 17'-2" height 8'-0"

Height above grade/roof to top of sign 49' above grade

Total Square Foot Area 137 Square Feet

Such sign shall comply with all applicable provisions of TITLE 17 of the Chicago Zoning Ordinance and all other applicable provisions of the Municipal Code of the City of Chicago governing the construction and maintenance of outdoor signs, signboards and structures.



Danny Solis, Alderman, 25th Ward

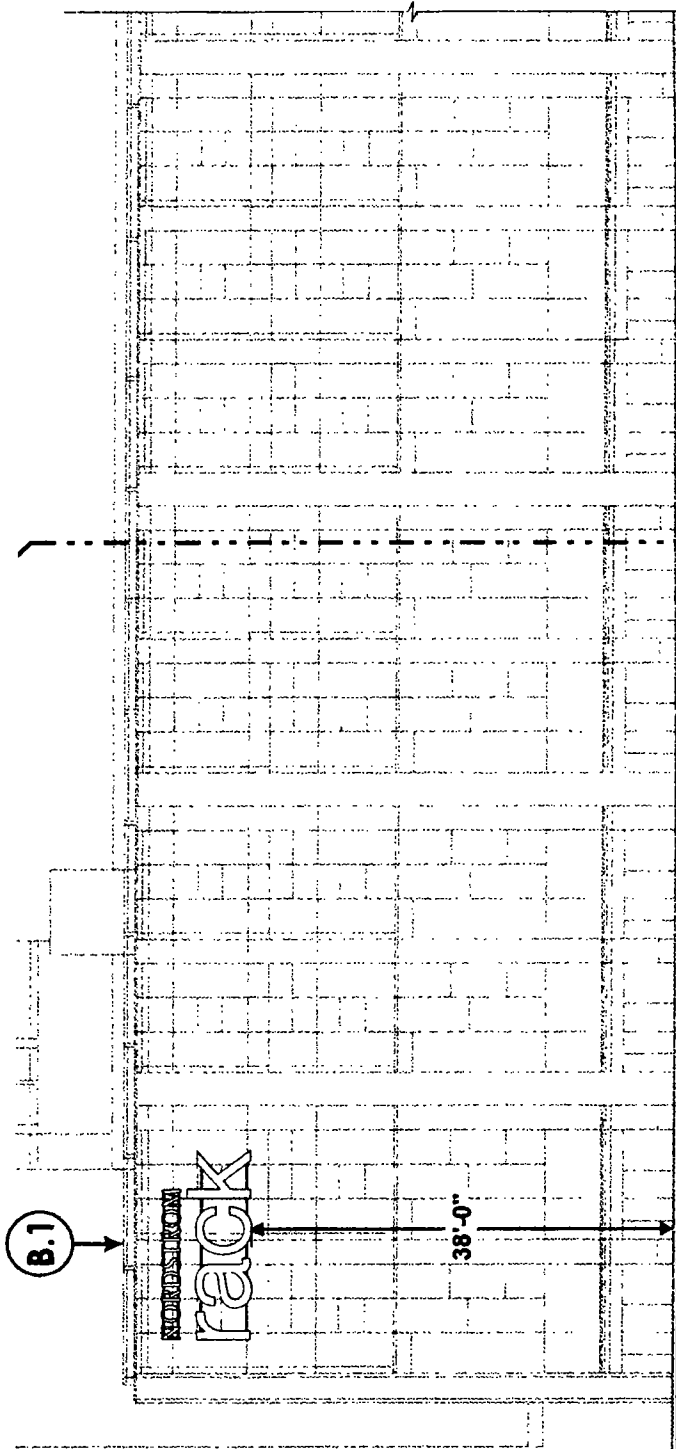

SIGN TYPES: B.1 / PARTIAL SOUTH ELEVATION

SCALE: 1/16" = 1'-0"

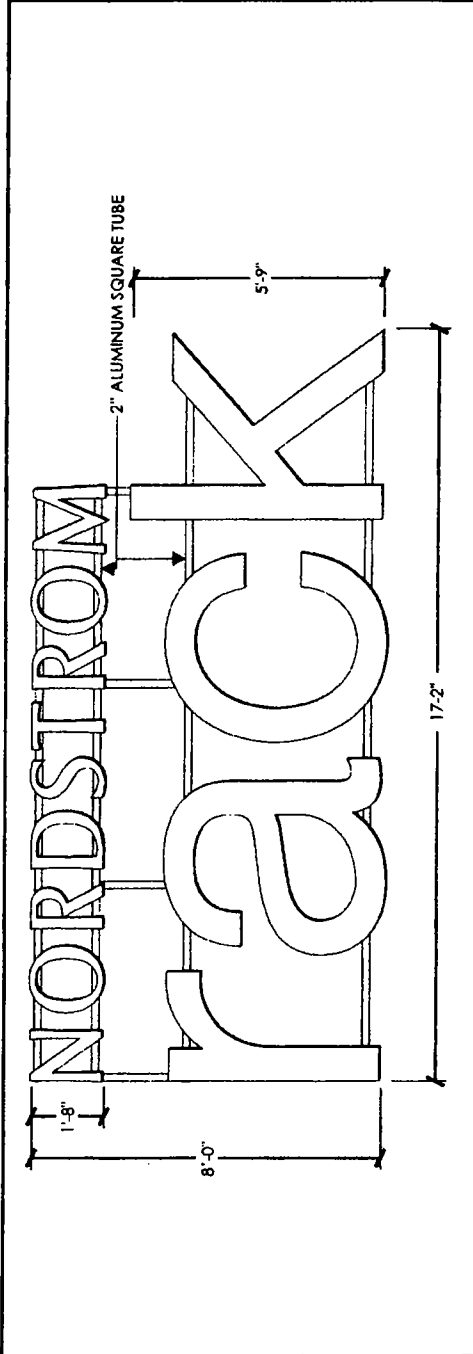

SIGN TYPE B.1 ELECTRICAL REQUIRED: 20 AMP / 120V 121 SQ. FT. SCALE: 1/4" = 1'



BLAIR SIGN PROGRAMS

Northern California:
(610) 337-9020
Southern California:
(619) 792-1600

9932 Prospect Ave
Studio 137
San Jose, CA 92071
blair@blairsign.net
CA License #677503

NORDSTROM
rack

CLIENT:
NORDSTROM rack
PROJECT:
Chicago, IL (The Marshall)
ADDRESS:
1100 South Canal St.
Chicago, IL 60607

STARTING DATE:
05/17/2014
BY:
K. Bennett
REVISIONS:

Section I
Sheet # 3

© 2014 BLAIR SIGN PROGRAMS



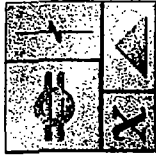

BLAIR SIGN PROGRAMS

9932 Prospect Ave
Studio 137
Santee, CA 92071

Northern California:
(619) 337-9020

Southern California:
(619) 792-1400

info@blairsign.net
CA License #677903

CLIENT:
NORDSTROM.net

PROJECT:
The Marnell (280)

ADDRESS:
1803 South Canal Street
Chicago, IL 60607

STARTING DATE:
02/14/2014

BY:
J. Wallace

REVISIONS:
04/17/2014 (1W)

© 2014 BLAIR SIGN PROGRAMS



MEMBER SINCE 2008

Section I

Sheet # 2.1

SCOPE OF WORK:

Sign(s) Type: B.1-B.2

Manufacture and install two (2) sets of channel letters as shown and as follows:

Illumination:

White (6500K) L.E.D.'s.
To use self-contained power supplies.

Body:

Back - .090 Aluminum,
5" deep returns - Letter returns .080
Aluminum sheet, provide top coats of
Polyurethane paint, over one coat epoxy
Primer matching Mathew's color N723 Black.
Inner body to have light-enhancing paint.

Faces:

Channel Letters:
3/16" Thick Plexiglass - 732B White
3/4" Trim Cap Black by Transco, Inc.
Stainless Steel Fasteners - Painted to match body.

Wireway:

2" Aluminum square tube,
Painted BM 2125-20 (Deep Space)
Clip System Attachment (See Sheet 2.2)

Incoming power/access:

Primary circuit(s) by others
120V req'd
Reasonable access req'd

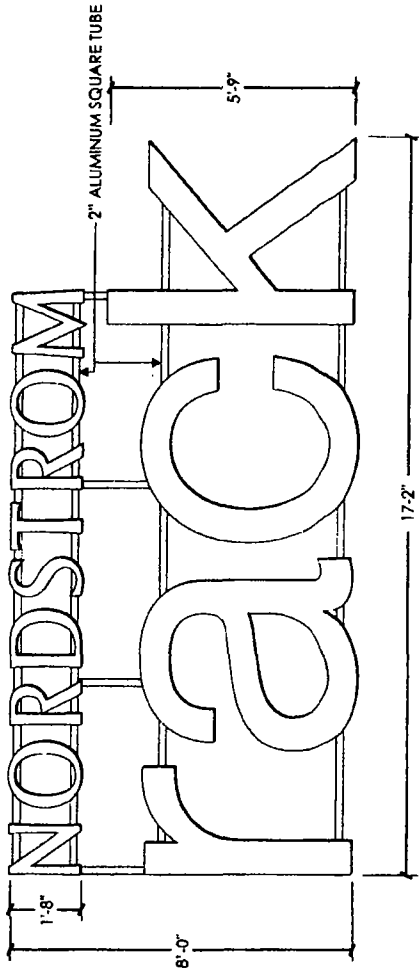

(FRONT VIEW)

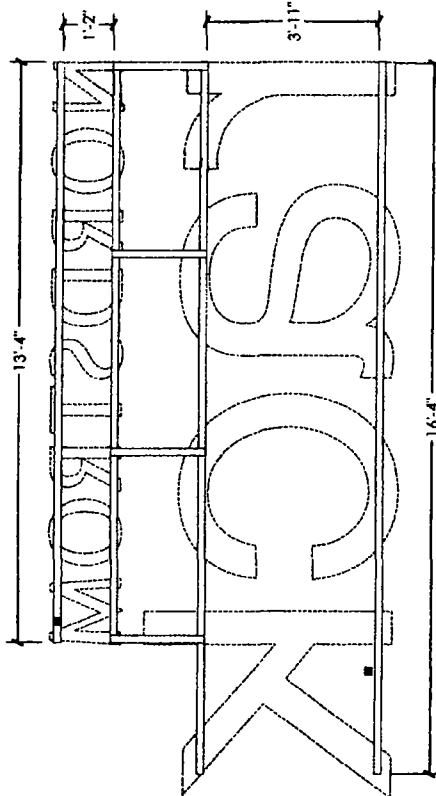

(REAR VIEW)

SIGN TYPE B.1-B.2

ELECTRICAL REQUIRED: 20 AMP / 120V

121 SQ. FT.

SCALE: 3/8" = 1'

CHANNEL LETTERS



City of Chicago



Or2014-239

Office of the City Clerk

Document Tracking Sheet

| | |
|---------------------------------|--|
| Meeting Date: | 5/28/2014 |
| Sponsor(s): | Solis (25) |
| Type: | Order |
| Title: | Issuance of permits for sign(s)/signboard(s) at 1100 S Canal St - 137 sq. ft. 49 ft. above grade |
| Committee(s) Assignment: | Committee on Zoning, Landmarks and Building Standards |

Committee on Zoning, Landmarks
and Building Standards
City Council Meeting, May 28, 2014
Alderman Danny Solis, 25th Ward
Sign Order

ORDERED, That the Commissioner of Buildings is hereby directed to issues sign permits to:

Blair Sign Programs
9935 Prospect Avenue, Studio 137
Santee, CA 92071

For the erection of a sign over 100 square feet (in area of one face) and over 24 feet above ground at:

1100 S. Canal Street
Chicago, IL 60607

Dimensions: length 17'-2" height 8'-0"

Height above grade/roof to top of sign 49' above grade

Total Square Foot Area 137 Square Feet

Such sign shall comply with all applicable provisions of TITLE 17 of the Chicago Zoning Ordinance and all other applicable provisions of the Municipal Code of the City of Chicago governing the construction and maintenance of outdoor signs, signboards and structures.

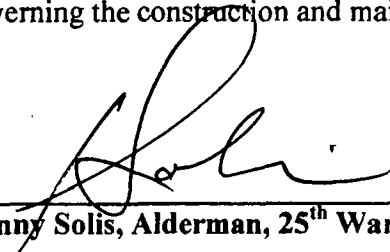

Danny Solis, Alderman, 25th Ward



City of Chicago



Or2014-241

Office of the City Clerk

Document Tracking Sheet

| | |
|---------------------------------|--|
| Meeting Date: | 5/28/2014 |
| Sponsor(s): | Burnett (27) |
| Type: | Order |
| Title: | Issuance of permits for sign(s)/signboard(s) at 2333 W Madison St |
| Committee(s) Assignment: | Committee on Zoning, Landmarks and Building Standards |

City Council

Meeting Date: May 28, 2014

Committee on Buildings (signs)

ORDERED, That the Commissioner of Buildings is hereby directed to
issue a sign permit to: (Contractor's name and address)

The Holland Design Group Inc.

1090 Brown St.

Wauconda, IL 60084

for the erection of a sign / signboard over 24 feet in height and / or over 100
square feet (in area of one face) at: (Business NAME & ADDRESS)

Petes Fresh Market 2333 W. Madison St.
Chicago IL 60612

Dimensions: Length 16.0 ft Height 5.0 ft

Height above grade / roof to top of sign 32 ft

TOTAL SQUARE FOOT AREA 80 sq ft

Such sign(s) shall comply with all applicable provisions of TITLE 17 of the
Chicago Zoning Ordinance and all other applicable provisions of the Municipal
Code of the City of Chicago governing the construction and maintenance of
outdoor signs, signboards and structures.

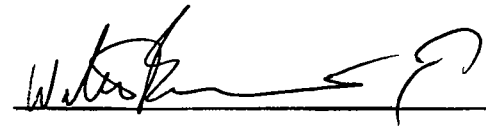

Alderman, 27th Ward



City of Chicago



Or2014-248

Office of the City Clerk

Document Tracking Sheet

| | |
|---------------------------------|--|
| Meeting Date: | 5/28/2014 |
| Sponsor(s): | Burnett (27) |
| Type: | Order |
| Title: | Issuance of permits for sign(s)/signboard(s) at 821 W Evergreen Ave - 560 sq. ft. |
| Committee(s) Assignment: | Committee on Zoning, Landmarks and Building Standards |



City of Chicago



Or2014-249

Office of the City Clerk

Document Tracking Sheet

| | |
|---------------------------------|--|
| Meeting Date: | 5/28/2014 |
| Sponsor(s): | Burnett (27) |
| Type: | Order |
| Title: | Issuance of permits for sign(s)/signboard(s) at 1333 N Kingsbury St |
| Committee(s) Assignment: | Committee on Zoning, Landmarks and Building Standards |



City of Chicago



Or2014-250

Office of the City Clerk

Document Tracking Sheet

| | |
|---------------------------------|--|
| Meeting Date: | 5/28/2014 |
| Sponsor(s): | Austin (34) |
| Type: | Order |
| Title: | Issuance of permits for sign(s)/signboard(s) at 1717 W 115th St |
| Committee(s) Assignment: | Committee on Zoning, Landmarks and Building Standards |

City Council, meeting date: _____
Committee on Zoning, Landmarks, & Building Standards

ORDERED, That the Commissioner of the Building Department is hereby directed to issue a sign permit to: *(Contractor's name and address)*

Doyle Signs, Inc

232 W Interstate Road

Addison, IL 60101

For the erection of a sign / signboard over twenty-four (24) feet in height and / or over one hundred (100) square feet (in area of one face) at:

On-Premise / Business ID signs: indicate Business Name and Address
Off-Premise / Advertising signs: must indicate that it is for Advertising

Maruichi Leavitt

1717 W 115th Street

Chicago, IL 60643

Such signs shall comply with all provisions of Title 17 of the Chicago Zoning Ordinance and all other applicable provisions of the Municipal Code of the City of Chicago governing the construction and maintenance of outdoor signs, sign boards, and structures.

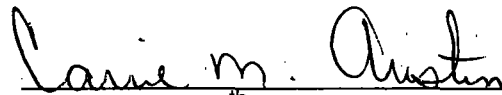

Alderman, 34th Ward

Carrie M Austin

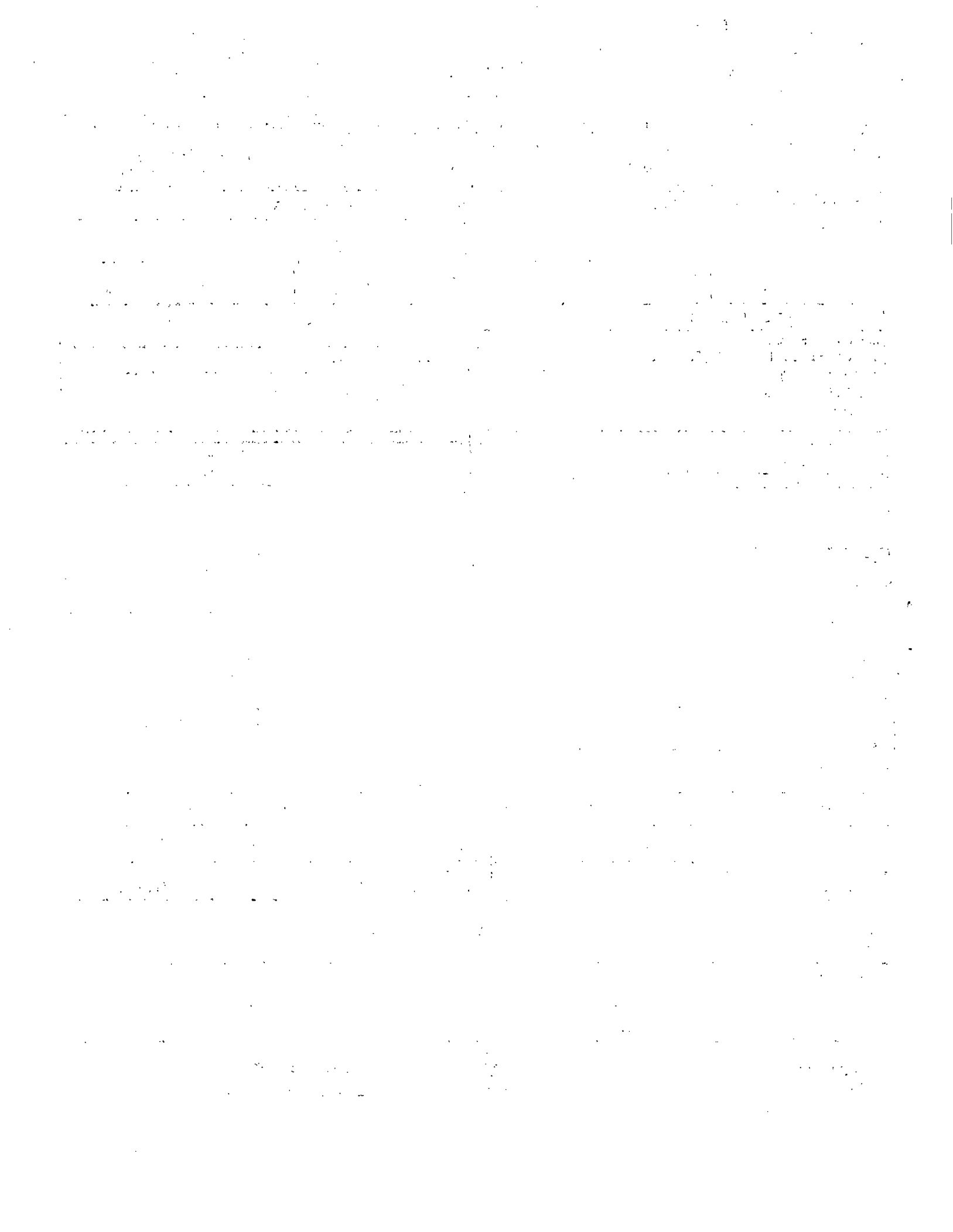



CITY OF CHICAGO

DEPARTMENT OF BUILDINGS

Sign Permit Application

| | | | | |
|---|--|---|-----------------------------|---|
| APPROVAL NUMBER | APPLICATION NUMBER 100469426 | ANNUAL FEE | WORK CODE | DRAWINGS ATTACHED <input type="checkbox"/> YES <input checked="" type="checkbox"/> NO |
| DATE OF APPLICATION 12/04/2012 | ADDRESS OF SIGN 1717 W 115TH ST, 60643- | | TYPE OF SIGN FLAT OR BOX | |
| BUILDING | ORIGINAL PERMIT NUMBER | LENGTH | FT. 22 | IN. 0 |
| TYPE OF PERMIT NEW CONSTRUCTION (SIGN) | | HEIGHT | FT. 8 | IN. 0 |
| PAYER OF ANNUAL INSPECTION MARUICHI LEAVITT, MARUICHI LEAVITT 1717 W 115TH ST CHICAGO, IL 60643 (630)543-9490 | | AREA | SQ. FT. 176 | WEIGHT LBS 300 |
| SIGN MANUFACTURER DOYLE SIGNS, INC | | SIGN HEIGHT ABOVE GRADE/ROOF | | FT. 22 |
| ADDRESS WHERE SIGN CAN BE SEEN PRIOR TO ERECTION | | SHAPE OF SIGN REGULAR | | |
| TICKET NUMBER 0 | | SIGN WILL READ MARUICHI LEAVITT | | |
| REINSPECTION CONTROL NUMBER <i>12 # F 31116</i> | | NO. OF LAMPS 22 | | |
| TYPE OF SUPPORT FOR SIGN BUILDING | | TOTAL WATTAGE 980 | | |
| SIGN BOARD SUPPORT MEMBERS NONE | | TYPE OF LAMP FLUORESCENT | | |
| ANNUAL FEE | | NO. OF BALLAST/TRANSFORMERS 4 | | |
| CONSTRUCTION FEE 200.00 | | INPUT OF TRANSFORMERS 120 | | |
| 1017 B FEE | | CONTRACTOR WILL INSTALL <input checked="" type="checkbox"/> FEEDERS <input checked="" type="checkbox"/> CUSTOMER LEADS | | |
| TOTAL FEE 200.00 | | TYPE OF SWITCH SPECIAL | | |
| AMOUNT PAID 200.00 | | LOCATION OF SWITCH LISTED FLUSH TOGGLE | | |
| BALANCE DUE | | SIGN LOCATION INSTALLATION OF (1) SINGLE FACED INTERNALLY ILLUMINATED WALL SIGN TO BE MOUNTED TO THE EAST BUILDING ELEVATION | | |

The undersigned certify that the statements in this application are true and correct and that all work done under the proposed permit will conform to the requirements of the Chicago Municipal Code

| | |
|--|--------|
| REG NO | E92684 |
| ELECT CONTR DOYLE SIGNS INC | ELECTR |
| ADDRESS 232 INTERSTATE RD - P.O. BOX 1068 ADDISON, IL 60101- | |
| SUPERVISOR SIGNATURE | |

| | | |
|--|--------|--------|
| BOND NO. <i>10416 Gild</i> | REG NO | E92684 |
| SIGN ERECTOR DOYLE SIGNS INC | SIGNER | |
| ADDRESS 232 INTERSTATE RD - P.O. BOX 1068 ADDISON IL, 60101- | | |
| SIGNATURE | | |

The permit issued on this application will authorize only signs here applied for. If other signs are to be erected they must be covered by additional permits

City of Chicago
Rahm Emanuel, Mayor



Department of Buildings
Michael Merchant, Commissioner

1. The first part of the document discusses the importance of maintaining accurate records of all transactions and activities. It emphasizes that proper record-keeping is essential for ensuring transparency and accountability in financial reporting.

2. The second part of the document outlines the various methods and techniques used to collect and analyze data. It highlights the need for a systematic approach to data collection and the importance of using reliable sources of information.

3. The third part of the document focuses on the analysis and interpretation of the collected data. It discusses the various statistical and analytical tools that can be used to identify trends, patterns, and relationships within the data.

4. The fourth part of the document discusses the importance of communicating the results of the analysis in a clear and concise manner. It emphasizes the need for effective communication skills and the use of appropriate visual aids to enhance the presentation of the findings.

5. The fifth part of the document discusses the importance of maintaining the confidentiality and security of the data. It highlights the need for appropriate safeguards and controls to protect the data from unauthorized access and disclosure.

6. The sixth part of the document discusses the importance of regularly reviewing and updating the data and analysis. It emphasizes the need for a continuous process of monitoring and evaluation to ensure the accuracy and relevance of the information.

7. The seventh part of the document discusses the importance of using the data and analysis to inform decision-making. It highlights the need for a data-driven approach to management and the use of the findings to identify areas for improvement and to develop effective strategies.

8. The eighth part of the document discusses the importance of maintaining a high level of ethical standards in the collection and use of data. It emphasizes the need for transparency, honesty, and integrity in all aspects of the data management process.

9. The ninth part of the document discusses the importance of staying up-to-date on the latest developments in data management and analysis. It highlights the need for continuous learning and professional development to ensure the effectiveness of the data management process.

10. The tenth part of the document discusses the importance of maintaining a strong relationship with the data sources and providers. It emphasizes the need for clear communication and collaboration to ensure the accuracy and reliability of the data.

| | |
|--|--|
| TYPE OF BUSINESS INDUST _____ Other: _____ Name: _____ LIC #: _____ Renewal Date: _____ | SIGN BOND REQUIRED? <input type="checkbox"/> YES COUNCIL ORDER REQUIRED <input checked="" type="checkbox"/> YES |
| Projects Over: <input checked="" type="checkbox"/> Private Property <input checked="" type="checkbox"/> Public Way Grant Permit #: _____ <input type="checkbox"/> Planned Development/Manufacturing PMD/PD#: _____ Zoning District: <u>M3</u> Other: <u>M3-3</u> | IS SPECIAL PERMISSION REQUIRED FROM CHIEF ELECTRICAL <input type="checkbox"/> YES IF YES, ATTACH LETTER OF REQUEST |
| TYPE OF SIGN: <input type="checkbox"/> ADVERTISING <input checked="" type="checkbox"/> ILLUMINATE <input type="checkbox"/> MOVEABLE <input checked="" type="checkbox"/> BUSINESS <input type="checkbox"/> FLASHING | TIME STAMP |
| TOTAL STREET FRONTAGE OF LOT (IN FEET) _____ 2,030 TOTAL AREA OF NEW SIGN (SQ.FT.) _____ 176 TOTAL AREA OF ALL SIGNS ON LOT (SQ.FT.) _____ 550 HEIGHT OF SIGN ABOVE GRADE (TO TOP) _____ 30ft 0in | SIGN CLERK _____ APPROVED FOR PERMIT _____ |
| DISTANCE OF CURB LINE OUTER EDGE (ft) _____ 125 DISTANCE OF STRUCTURE INNER EDGE (ft) _____ 125 DISTANCE FROM (ft): A. PUBLIC PARK (OVER 10 ACRES) _____ 1,292 B. EXPRESSWAY (IF LESS THAN 1,000 FT.) _____ 805 C. RESIDENCE DISTRICT (ADVERTISING SIGNS ONLY) _____ 95 | REMARKS |
| IF REPLACEMENT SIGN OR CHANGE OF FACE, WHAT DOES THE EXISTING SIGN READ? Original Payee: _____ Landmark Hold: <input type="checkbox"/> Status: _____ | |
| ZONING (OFFICE USE ONLY) | |

CITY OF CHICAGO
 DEPARTMENT OF ZONING AND LAND USE PLANNING
 SIGN SITE PLAN
 (ALL INFORMATION MUST BE COMPLETED AND LEGIBLE)

Site Address: 1717 W. 115th St. of applications

Sign Company: Dale Signs Inc. Rep Name: Lisa Neal

Phone: (800) 513-9400 EXT 25 (Below: Building, streets and location of sign on lot or structure)
 North

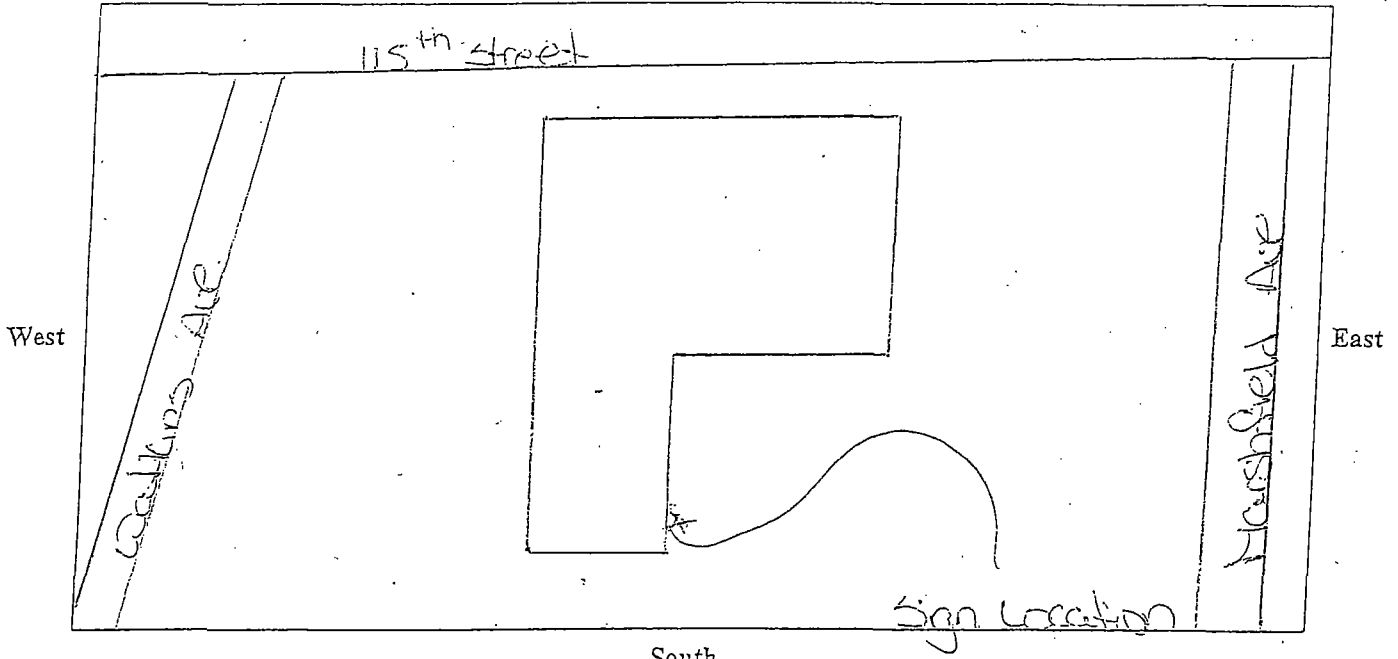

| | | | | | |
|---------------------------|-------------------------------------|--------------------------|-------------------------------------|------------------------------|-------------------------------------|
| SIGN USE: | | TYPE OF SIGN: | | SIGN CHARACTERISTICS: | |
| Bus. ID (On-premise) | <input checked="" type="checkbox"/> | Flat Wall | <input checked="" type="checkbox"/> | Non-Illuminated | <input type="checkbox"/> |
| Business Lice. # | | Freestanding | <input type="checkbox"/> | Illuminated | <input checked="" type="checkbox"/> |
| Advertising (Off-premise) | <input type="checkbox"/> | Awning | <input type="checkbox"/> | Changing Image | <input type="checkbox"/> |
| | | Marquee | <input type="checkbox"/> | Video Display | <input type="checkbox"/> |
| | | High Rise Building | <input type="checkbox"/> | Flashing | <input type="checkbox"/> |
| | | Projecting Private | <input type="checkbox"/> | | |
| PERMIT TYPE: | | Projecting Public Way | <input type="checkbox"/> | | |
| New Construction | <input checked="" type="checkbox"/> | Public Way Use -Permit # | <input type="checkbox"/> | | |
| Change of Face | | | | | |
| Previous Permit # | <input type="checkbox"/> | | | | |

TOTAL SQUARE FOOTAGE:
 Square footage of this proposed sign 1710
 Gross area of all proposed signs 550
 Area of all existing signs
 (not including proposed) on Zoning Lot 0

DISTANCE FROM:
 Curb Line: 135
 Expressway, Toll Roads
 or Major Route
 (n/a if over 1000 ft) 805
 Park (over 10 acres) 1370
 Residential Zone 95
 Existing Off-premise on
 same side of street: N/A

Signature: Lisa Neal

Date: 12-4-13

(Revised 4/10)



City of Chicago



Or2014-245

Office of the City Clerk

Document Tracking Sheet

| | |
|---------------------------------|---|
| Meeting Date: | 5/28/2014 |
| Sponsor(s): | Reilly (42) |
| Type: | Order |
| Title: | Issuance of permits for sign(s)/signboard(s) at 737 N Michigan Ave |
| Committee(s) Assignment: | Committee on Zoning, Landmarks and Building Standards |

Committee on Zoning, Landmarks
and Building Standards
City Council Meeting May 28, 2014
Alderman Brendan Reilly, 42nd Ward
Sign Order

ORDERED, That the Commissioner of Buildings is hereby directed to issue a sign permit to:

Design Group
2135 South Frontage Road
Des Plaines, Illinois 60018

For the erection of a sign/signboard over 24 feet in height and/or over 100 square feet (in area of one face) at:

Neiman Marcus
737 North Michigan Avenue
Chicago, Illinois 60611

Dimensions: length 23' - 5" height 9' - 0"
Height above grade/roof to top of sign 65'
Total Square Foot Area 211 square feet
Elevation South

Such sign shall comply with all applicable provisions of TITLE 17 of the Chicago Zoning Ordinance and all other applicable provisions of the Municipal Code of the City of Chicago governing the construction and maintenance of outdoor signs, signboards and structures.

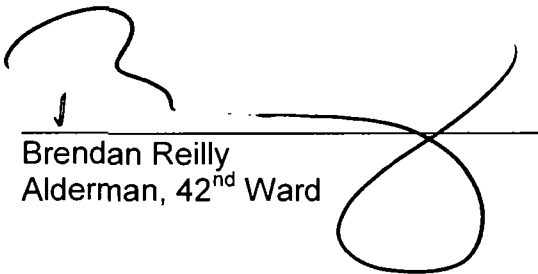

Brendan Reilly
Alderman, 42nd Ward

210.75 Sq. Ft.

Gloss Black

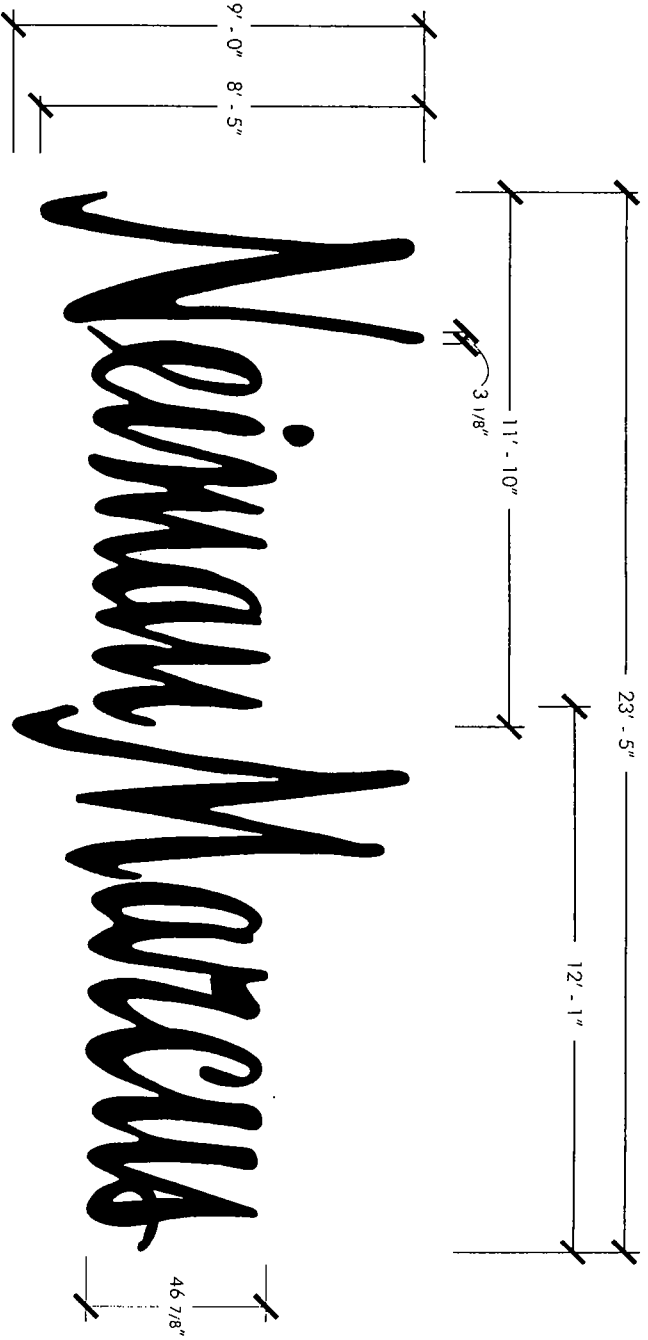

ELEVATION VIEW
Scale - 3/8" = 1'

DESCRIPTION

- One (1) Set of Rear Lit Channel Letters
- Internally Illuminated
- Electro LED Lighting (Firing/Lighting Toward Wall) (See Cut Sheet)
- (125 Faces & 080 Returns) Formed and Welded Aluminum
- Painted Gloss Black
- 3/8" Dia x 7" lg. Expansion Anchors
- Clear Polycarbonate Backer

120 Volts / 20A



2135 S. Frontage Rd
Des Plaines, IL 60018
847-390-0350 - Fax 847-390-9231
sgn@designgroupsignage.com

Job # 4938
Neimon Marcus
737 N Michigan Ave
Chicago, IL

| Name | Date | Notes |
|------|--------------------|-----------------------------------|
| SG | August 21, 2013 | Initial Sign Drawing |
| SG | September 13, 2013 | Added second Rendering |
| SG | September 24, 2013 | Changed Depth and Stand off Specs |

Drawn By: SG
Checked By:

Page 2 of 5

These plans are exclusive property of DesignGroup Signage Corp. and are the result of the original work of its employees. They are submitted to your company for the sole purpose of your consideration of whether to purchase these plans or to purchase from DesignGroup Signage Corp. a sign manufactured according to these plans. Distribution or exhibition of these plans to construct a sign similar to the one herein is strictly prohibited. In the event that such exhibition occurs, DesignGroup Signage Corp. expects to be reimbursed \$300.00 in compensation for time and effort entailed in creating these plans.



Approved: _____ Date: _____

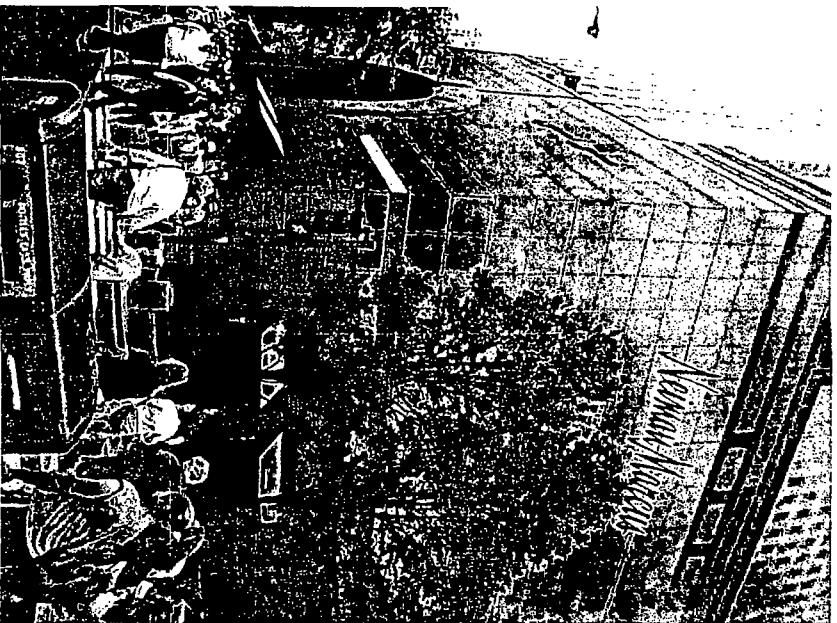

ELEVATION VIEW (SUPERIOR AVE)
Scale - NTS

DesignGroup
Signage Corp.

2133 S. Lawrence Rd.
Oak Brook, IL 60157
708-590-0300 Fax 708-590-3223
signage@designgroup.com

These plans are the exclusive property of DesignGroup Signage Corp. and are the result of the original work of its employees. They are submitted to your company for the sole purpose of your consideration of whether to purchase these plans or to purchase from DesignGroup Signage Corp. a sign manufactured according to these plans. Distribution or exhibition of these plans to construct a sign similar to the one herein is strictly forbidden. In the event that such exhibition occurs, DesignGroup Signage Corp. expects to be reimbursed \$500.00 in compensation for time and effort involved in creating these plans.

Job # 4938
Norman Morgan
737 N. Michigan Ave
Chicago, IL

| Name | Date | Notes |
|------|--------------------|------------------------------------|
| SG | August 21, 2013 | in of Sign Drawing |
| SG | September 11, 2013 | Approved Revised Drawing |
| SG | September 25, 2013 | Changed Depth and Spacing of Signs |

Drawn By: SG
Checked By:
Page 3 of 3

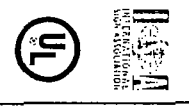

Approved _____
Date _____

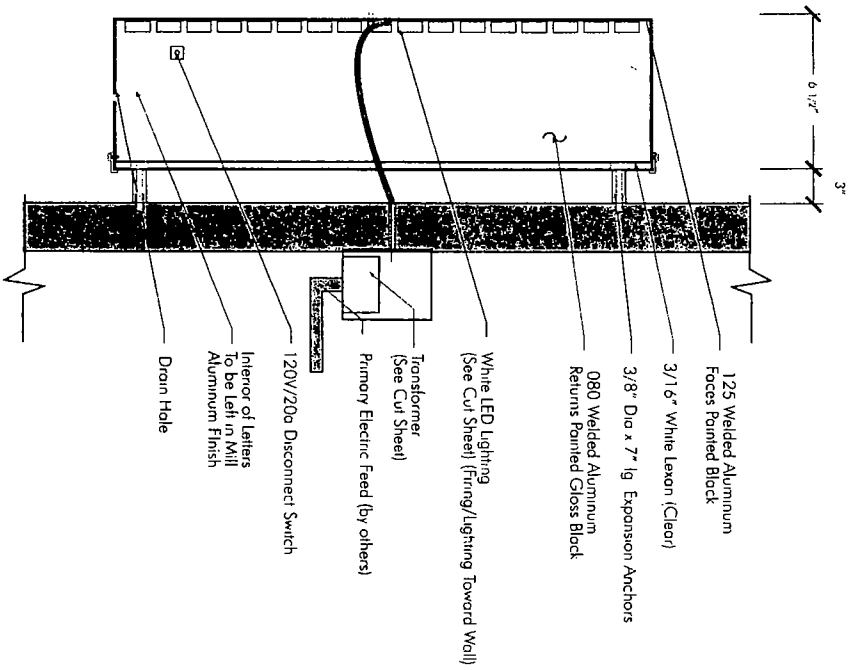

SECTION VIEW
Scale - 3/8" = 1'

Approved: _____ Date: _____

2135 S. Frontage Rd.
Des. Plains, IL 60016
847-390-0350 - Fax 847-390-9231
sgpersonnel@designgroupcorp.com

DesignGroup Signage Corp.

These plans are the exclusive property of DesignGroup Signage Corp. and are the result of the original work of its employees. They are submitted to your company for the sole purpose of your consideration of whether to purchase these plans or to purchase from DesignGroup Signage Corp. a sign manufactured according to these plans. Distribution or exhibition of these plans to construct a sign similar to the one herein is strictly forbidden. In the event that such exhibition occurs, DesignGroup Signage Corp. expects to be reimbursed \$500.00 in compensation for time and effort entailed in creating these plans.

| | | |
|---------------------|--------------------|------------------------------------|
| Job # 4938 | Name: | Notes: |
| Neumon Marcus | SG | Initial Sign Drawing |
| 737 N. Michigan Ave | SG | Added second Rendering |
| Chicago, IL | SG | Changed Depth and Spacing of Specs |
| Down By: SG | Date: | |
| Checked By: | August 21, 2013 | |
| Page 4 of 5 | September 12, 2013 | |
| | September 24, 2013 | |



NM-108-120

○ Represents 1/2" Diameter Holes for Mounting with 3/8" Dia x 4"lg Expansion Anchors

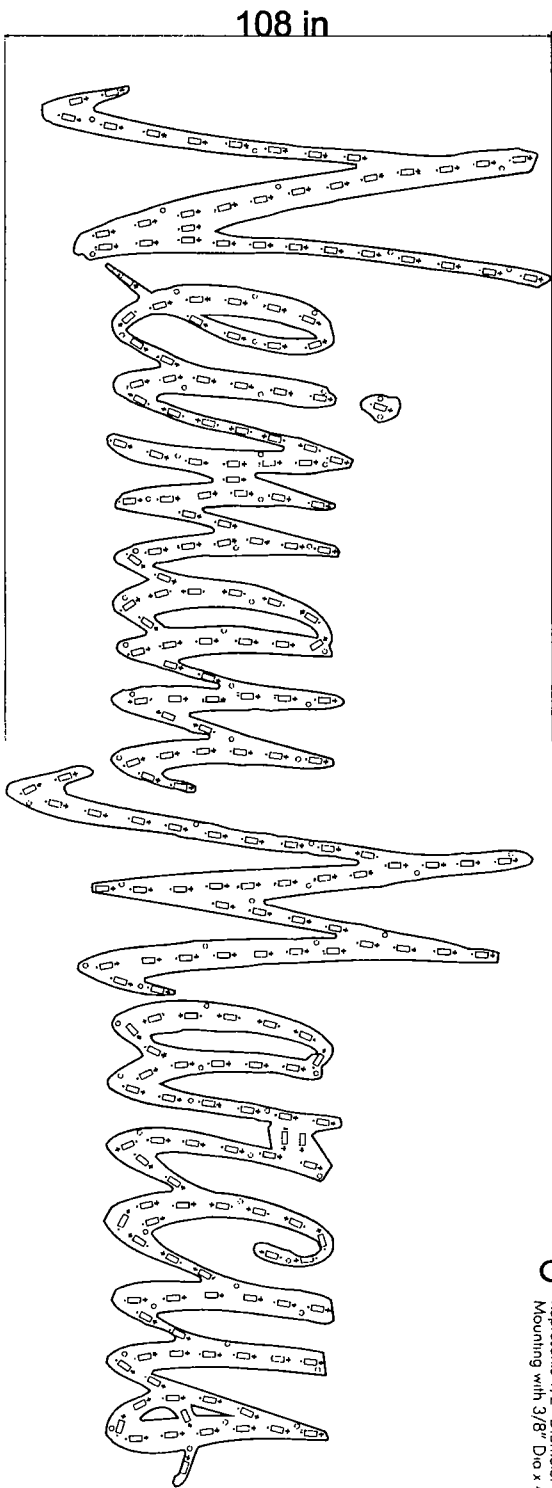

RETURN DEPTH = 5"
STAND-OFF = 3" HALO

LED MATERIAL LIST

ED12-CW = 228
SL-B = 100
HEYCLIP3893 = 200
C2240-12 = 5

GENERAL SPECIFICATIONS

INSTALLATION DIAGRAM
C2240-12 TRANSFORMER

DIMENSIONS
13" L x 4" W x 3 1/2" H

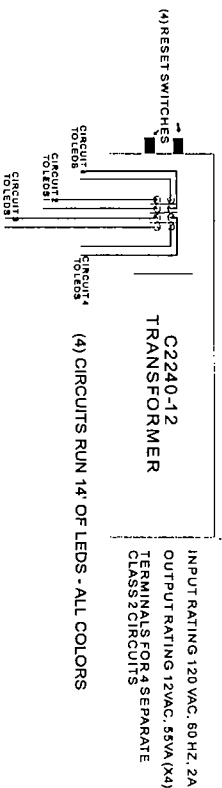

12 VOLT

GENERAL NOTES

Power supplies can be located 30 ft. away if using 14 gauge wire and 50 ft. away if using 12 gauge wire.

ELECTRICAL NOTES

Power Supply:
CLASS 2 TRANSFORMERS
.240 KVA, 4 total runs each.
Voltage: 120
Amps: 2.0 Each Transformer @ Full Load
Circuits: (1) 20 amp

CUSTOMER: NEIMAN MARCUS
CONTACT:
PROJECT: NEIMAN MARCUS

QUOTE #

18637

This drawing is the property of Electrical ED
Any unauthorized use is forbidden
ElectraLED, Inc.
12722 62nd ST N., SUITE 200
LARGO, FL 33773
LOCAL 727-561-7610
FAX 727-561-7605
866-561-7610
Web Site - www.electraled.com
Email - info@electraled.com



ElectraLED, Inc.



CITY OF CHICAGO

DEPARTMENT OF BUILDINGS

Sign Permit Application

| | | | | |
|-----------------|---------------------------------|------------|-----------|--|
| APPROVAL NUMBER | APPLICATION NUMBER 100539407 | ANNUAL FEE | WORK CODE | DRAWINGS ATTACHED <input checked="" type="checkbox"/> YES <input type="checkbox"/> NO |
|-----------------|---------------------------------|------------|-----------|--|

| | | | |
|--|---|-----------------------------|--|
| DATE OF APPLICATION | 05/06/2014 | | |
| ADDRESS OF SIGN | 737 N MICHIGAN AVE, 60611- | | |
| BUILDING | ORIGINAL PERMIT NUMBER | | |
| TYPE OF PERMIT | NEW CONSTRUCTION (SIGN) | | |
| PAYER OF ANNUAL INSPECTION | PIPER, MARYLOU 737 N MICHIGAN AVENUE CHICAGO, IL 60611 (312)642-5900 | | |
| SIGN MANUFACTURER | DESIGN GROUP SIGNAGE CORP | | |
| ADDRESS WHERE SIGN CAN BE SEEN PRIOR TO ERECTION | | | |
| TICKET NUMBER | 0 | REINSPECTION CONTROL NUMBER | |
| TYPE OF SUPPORT FOR SIGN | BUILDING | | |
| SIGN BOARD SUPPORT MEMBERS | STEEL | | |
| ANNUAL FEE | | | |
| CONSTRUCTION FEE | 200.00 | Check # for Zoning | |
| 1017 B FEE | | | |
| TOTAL FEE | 200.00 | | |
| AMOUNT PAID | 200.00 | Check # for DCAP | |
| BALANCE DUE | | | |

| | | | | | |
|------------------------------|--|---------|--|------------|---------|
| TYPE OF SIGN | FLAT OR BOX | | | | |
| LENGTH | FT 23 | IN 5 | HEIGHT | FT 9 | IN 0 |
| AREA | SQ FT 211 | WEIGHT | | LBS 350 | |
| SIGN HEIGHT ABOVE GRADE/ROOF | | | | FT 65 | |
| SHAPE OF SIGN | REGULAR | | | | |
| SIGN WILL READ | NEIMAN MARCUS | | | | |
| NO OF LAMPS | 1 | | TOTAL WATTAGE | 12 | |
| TYPE OF LAMP | OTHER | | | | |
| NO OF BALLAST/TRANSFORMERS | 5 | | INPUT OF TRANSFORMERS | 120 | |
| CONTRACTOR WILL INSTALL | <input checked="" type="checkbox"/> FEEDERS | | <input checked="" type="checkbox"/> CUSTOMER LEADS | | |
| TYPE OF SWITCH | KNIFE | | | | |
| LOCATION OF SWITCH | OUTSIDE SIGN | | | | |
| SIGN LOCATION | INSTALL NEW INTERNALLY ILLUMINATED REVERSE CHANNEL LETTERS ; | | | | |

The undersigned certify that the statements in this application are true and correct and that all work done under the proposed permit will conform to the requirements of the Chicago Municipal Code.

| | |
|----------------------|--|
| REG NO | E92009 |
| ELECT CONTR | HOWARD UNELL |
| ELECTR | |
| ADDRESS | 0N730 BARRY AVE. WHEATON, IL 60187- |
| SUPERVISOR SIGNATURE | <i>Howard Unell</i> |

| | | |
|--------------|---|--------|
| BOND NO | REG NO | N92250 |
| SIGN ERECTOR | DESIGN GROUP | SIGNER |
| ADDRESS | 2135 S. FRONTAGE RD DES PLAINES IL, 60018- | |
| SIGNATURE | <i>[Signature]</i> | |

The permit issued on this application will authorize only signs here applied for. If other signs are to be erected they must be covered by additional permits.

City of Chicago
Rahm Emanuel, Mayor



Department of Buildings
Felicia Davis, Commissioner

| | |
|--|--|
| TYPE OF BUSINESS <u>OTHER</u> Other. <u>RETAIL</u> Name <u>NEIMAN MARCUS</u> LIC # _____ Renewal Date _____ | SIGN BOND REQUIRED? <input type="checkbox"/> YES COUNCIL ORDER REQUIRED <input checked="" type="checkbox"/> YES IS SPECIAL PERMISSION REQUIRED FROM CHIEF ELECTRICAL <input type="checkbox"/> YES IF YES, ATTACH LETTER OF REQUEST |
| Projects Over: <input checked="" type="checkbox"/> Private Property <input checked="" type="checkbox"/> Public Way Grant Permit #. _____ <input checked="" type="checkbox"/> Planned Development/Manufacturing PMD/PD# <u>PD218</u> Zoning District <u>OTHER</u> Other. <u>PD218</u> | TIME STAMP |
| TYPE OF SIGN: <input type="checkbox"/> ADVERTISING <input checked="" type="checkbox"/> ILLUMINATE <input type="checkbox"/> MOVEABLE <input checked="" type="checkbox"/> BUSINESS <input type="checkbox"/> FLASHING | |
| TOTAL STREET FRONTAGE OF LOT (IN FEET) _____ 234 TOTAL AREA OF NEW SIGN (SQ FT.) _____ 211 TOTAL AREA OF ALL SIGNS ON LOT (SQ FT.) _____ 210 HEIGHT OF SIGN ABOVE GRADE (TO TOP) _____ 74ft 0in | |
| DISTANCE OF CURB LINE OUTER EDGE (ft) _____ 29 DISTANCE OF STRUCTURE INNER EDGE (ft) _____ 29 | SIGN CLERK _____ APPROVED FOR PERMIT _____ |
| DISTANCE FROM (ft). A PUBLIC PARK (OVER 10 ACRES) _____ 1,000 B EXPRESSWAY (IF LESS THAN 1,000 FT) _____ 1,000 C RESIDENCE DISTRICT (ADVERTISING SIGNS ONLY) _____ 1,000 | REMARKS |
| IF REPLACEMENT SIGN OR CHANGE OF FACE, WHAT DOES THE EXISTING SIGN READ? Original Payee: _____ Landmark Hold: <input type="checkbox"/> Status: _____ | |
| ZONING (OFFICE USE ONLY) | |



City of Chicago



Or2014-246

Office of the City Clerk

Document Tracking Sheet

| | |
|---------------------------------|--|
| Meeting Date: | 5/28/2014 |
| Sponsor(s): | Reilly (42) |
| Type: | Order |
| Title: | Issuance of permits for sign(s)/signboard(s) 549 N Wells St - north elevation |
| Committee(s) Assignment: | Committee on Zoning, Landmarks and Building Standards |

Committee on Zoning, Landmarks
and Building Standards
City Council Meeting
Alderman Brendan Reilly, 42nd Ward
Off-premise advertising Sign Order

ORDERED, That the Commissioner of Buildings is hereby directed to issue a sign permit to:

Project Outdoor, LLC
188 North Wells Street, Suite 302
Chicago, IL 60608

For the erection of a sign/signboard over 24 feet in height and/or over 100 square feet (in area of one face) at:

549 North Wells Street (north elevation)
Change of face- advertising wall sign

Dimensions: length 36' height 10' - 6"

Height above grade/roof to top of sign 48 feet

Total Square Foot Area 378 square feet

Date of Application August 30, 2013

Such sign shall comply with all applicable provisions of TITLE 17 of the Chicago Zoning Ordinance and all other applicable provisions of the Municipal Code of the City of Chicago governing the construction and maintenance of outdoor signs, signboards and structures.

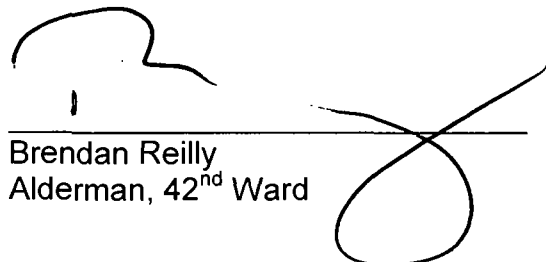

Brendan Reilly
Alderman, 42nd Ward



CITY OF CHICAGO

DEPARTMENT OF BUILDINGS**Sign Permit Application**

| | | | | |
|---|---|---|-----------------------------|---|
| APPROVAL NUMBER | APPLICATION NUMBER 100506712 | ANNUAL FEE | WORK CODE | DRAWINGS ATTACHED <input type="checkbox"/> YES <input type="checkbox"/> NO |
| DATE OF APPLICATION 08/30/2013 | ADDRESS OF SIGN 549 N WELLS ST, 60654- | | TYPE OF SIGN FLAT OR BOX | |
| BUILDING | ORIGINAL PERMIT NUMBER | LENGTH | FT 36 | IN. 6 |
| TYPE OF PERMIT NEW CONSTRUCTION (SIGN) | | HEIGHT | FT 10 | IN. 6 |
| PAYER OF ANNUAL INSPECTION ABU-GHAZALEH, WALID 188 N WELLS ST CHICAGO, IL 60606 (312)504-5347 | | AREA | SQ FT 378 | WEIGHT 100 |
| SIGN MANUFACTURER METROMEDIA | | SIGN HEIGHT ABOVE GRADE/ROOF | | FT. 37 |
| ADDRESS WHERE SIGN CAN BE SEEN PRIOR TO ERECTION | | SHAPE OF SIGN REGULAR | | |
| TICKET NUMBER 0 | | SIGN WILL READ VARIOUS ACCOUNTS | | |
| REINSPECTION CONTROL NUMBER | | NO OF LAMPS 2 | | |
| TYPE OF SUPPORT FOR SIGN BUILDING | | TOTAL WATTAGE 800 | | |
| SIGN BOARD SUPPORT MEMBERS OTHER | | TYPE OF LAMP HIGH DENSITY DISCHARGE | | |
| ANNUAL FEE | | NO OF BALLAST TRANSFORMERS 2 | | |
| CONSTRUCTION FEE 1,000.00 | | INPUT OF TRANSFORMERS 120V | | |
| 1017 B FEE | | CONTRACTOR WILL INSTALL <input checked="" type="checkbox"/> FEEDERS <input checked="" type="checkbox"/> CUSTOMER LEADS | | |
| TOTAL FEE 1,000.00 | | TYPE OF SWITCH KNIFE | | |
| AMOUNT PAID 500.00 | | LOCATION OF SWITCH OUTSIDE SIGN | | |
| BALANCE DUE \$ 500.00 | | SIGN LOCATION RE-FLECT SIGN (ORIGINAL PERMIT # 378370) [PER M.C.C. ORDINANCE FOR FLAT WALL SIGN ON NORTH ELEVATION | | |
| Check # for Zoning | | | | |
| Check # for DCAP | | | | |

The undersigned certify that the statements in this application are true and correct and that all work done under the proposed permit will conform to the requirements of the Chicago Municipal Code.

| | | |
|--|--|----------------------------------|
| REG NO. E94475 | BOND NO. | REG NO. N93194 |
| ELECT CONTR PNA ELECTRICAL SERVICES INC. | ELECTR | SIGN ERECTOR LINCOLN SERVICES |
| ADDRESS 6454 S TALMAN AVENUE CHICAGO, IL 60629 | ADDRESS P.O. BOX 64479 CHICAGO IL, 60664 | SIGNER |
| SUPERVISOR SIGNATURE <i>[Signature]</i> | SIGNATURE <i>[Signature]</i> | |

The permit issued on this application will authorize only signs here applied for. If other signs are to be erected they must be covered by additional permits.

City of Chicago
Rahm Emanuel, MayorDepartment of Buildings
Felicia Davis, Commissioner

| | |
|--|--|
| TYPE OF BUSINESS COMMERCIAL Other _____ Name: _____ LIC #: _____ Renewal Date: _____ | SIGN BOND REQUIRED? <input checked="" type="checkbox"/> YES <hr/> COUNCIL ORDER REQUIRED <input type="checkbox"/> YES <hr/> IS SPECIAL PERMISSION REQUIRED FROM CHIEF ELECTRICAL <input type="checkbox"/> YES <hr/> IF YES, ATTACH LETTER OF REQUEST <hr/> TIME STAMP |
| Projects Over: <input checked="" type="checkbox"/> Private Property <input checked="" type="checkbox"/> Public Way Grant Permit # _____ <input type="checkbox"/> Planned Development/Manufacturing PMD/PD#: _____ Zoning District: DX Other _____ | TYPE OF SIGN: <input checked="" type="checkbox"/> ADVERTISING <input checked="" type="checkbox"/> ILLUMINATE <input type="checkbox"/> MOVABLE <input type="checkbox"/> BUSINESS <input type="checkbox"/> FLASHING |
| TOTAL STREET FRONTAGE OF LOT (IN FEET) <u>200</u> <hr/> TOTAL AREA OF NEW SIGN (SQ FT) <u>378</u> <hr/> TOTAL AREA OF ALL SIGNS ON LOT (SQ FT.) <u>816</u> <hr/> HEIGHT OF SIGN ABOVE GRADE (TO TOP) <u>47ft 6in</u> | SIGN CLERK _____ APPROVED FOR PERMIT _____ |
| DISTANCE OF CURB LINE OUTER EDGE (ft) <u>10</u> DISTANCE OF STRUCTURE INNER EDGE (ft) <u>10</u> <hr/> DISTANCE FROM (ft) A. PUBLIC PARK (OVER 10 ACRES) <u>1,000</u> B. EXPRESSWAY (IF LESS THAN 1,000 FT) <u>1,000</u> C. RESIDENCE DISTRICT (ADVERTISING SIGNS ONLY) <u>250</u> | REMARKS |
| IF REPLACEMENT SIGN OR CHANGE OF FACE, WHAT DOES THE EXISTING SIGN READ? Original Payee: _____ Landmark Hold: <input type="checkbox"/> Status: _____ | |
| ZONING (OFFICE USE ONLY) | |

CITY OF CHICAGO
DEPARTMENT OF ZONING AND LAND USE PLANNING
SIGN SITE PLAN
(ALL INFORMATION MUST BE COMPLETED AND LEGIBLE)

Site Address: 549 N Wells St, Chicago, IL 60654 (North Elevation) 1 of 1 applications

Sign Company: Project Outdoor LLC Rep Name: Walid Abu-Ghazaleh

Phone (312) 504 - 5347 EXT (Below: Building, streets and location of sign on lot or structure)
 North

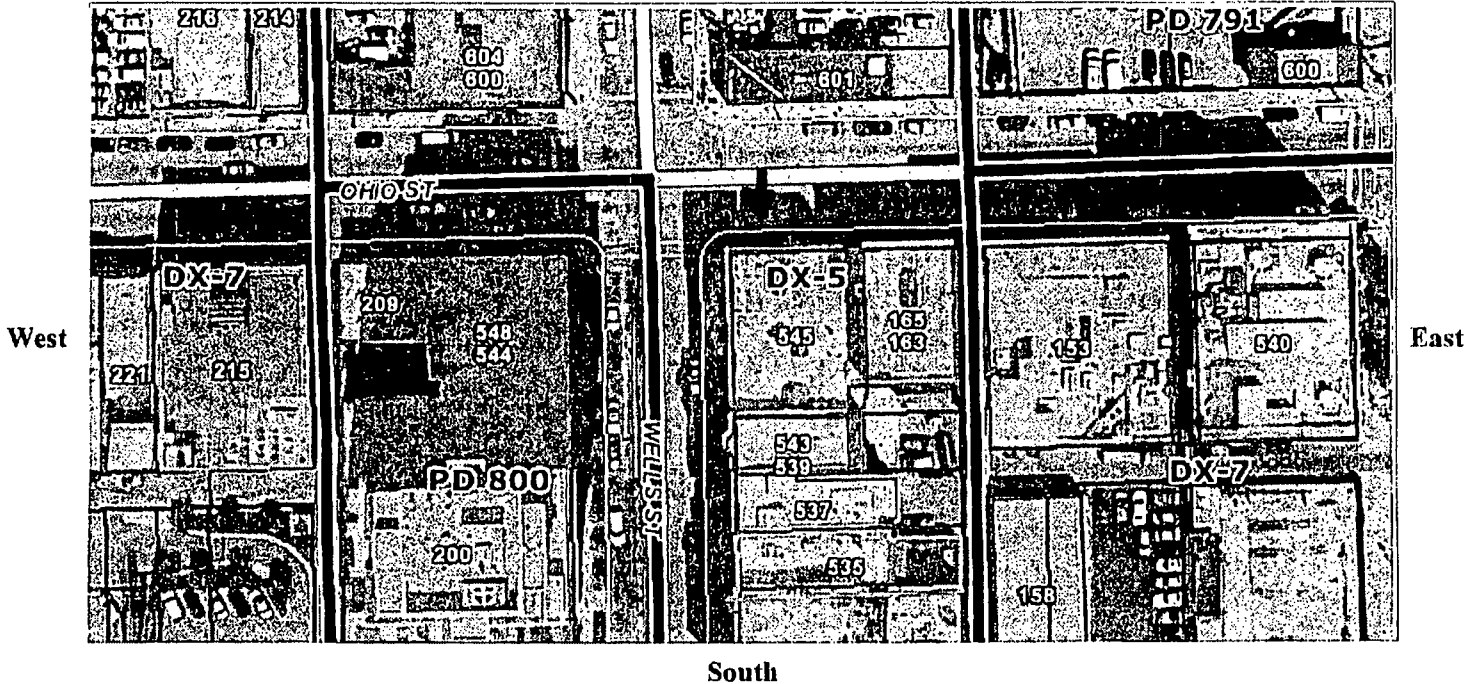

South

SIGN USE:

Bus. ID (On-premise)

Business Lice. #

Advertising (Off-premise)

PERMIT TYPE:

New Construction

Change of Face

Previous Permit #

378370

TOTAL SQUARE FOOTAGE:

Square footage of this proposed sign 378

Gross area of all proposed signs 378

Area of all existing signs

(not including proposed) on Zoning Lot 90 sf

TYPE OF SIGN:

Flat Wall

Freestanding

Awning

Marquee

High Rise Building

Projecting Private

Projecting Public Way

Public Way Use -Permit #

SIGN CHARACTERISTICS:

Non- Illuminated

Illuminated

Changing Image

Video Display

Flashing

DISTANCE FROM:

Curb Line: 10'

Expressway, Toll Roads or Major Route

(n/a if over 1000 ft) 850'

Park (over 10 acres) 1985'

Residential Zone 1200'

Existing Off-premise on same side of street: 80'

Signature: 

Date: 4-15-2014



City of Chicago



Or2014-247

Office of the City Clerk

Document Tracking Sheet

| | |
|---------------------------------|---|
| Meeting Date: | 5/28/2014 |
| Sponsor(s): | Reilly (42) |
| Type: | Order |
| Title: | Issuance of permits for sign(s)/signboard(s) at 549 N Wells St - west elevation |
| Committee(s) Assignment: | Committee on Zoning, Landmarks and Building Standards |

Committee on Zoning, Landmarks
and Building Standards
City Council Meeting
Alderman Brendan Reilly, 42nd Ward
Off-premise advertising Sign Order

ORDERED, That the Commissioner of Buildings is hereby directed to issue a sign permit to:

Project Outdoor, LLC
188 North Wells Street, Suite 302
Chicago, IL 60608

For the erection of a sign/signboard over 24 feet in height and/or over 100 square feet (in area of one face) at:

549 North Wells Street (west elevation)
Change of face- advertising wall sign

Dimensions: length 36' height 10' – 6"
Height above grade/roof to top of sign 48 feet
Total Square Foot Area 378 square feet
Date of Application August 30, 2013

Such sign shall comply with all applicable provisions of TITLE 17 of the Chicago Zoning Ordinance and all other applicable provisions of the Municipal Code of the City of Chicago governing the construction and maintenance of outdoor signs, signboards and structures.

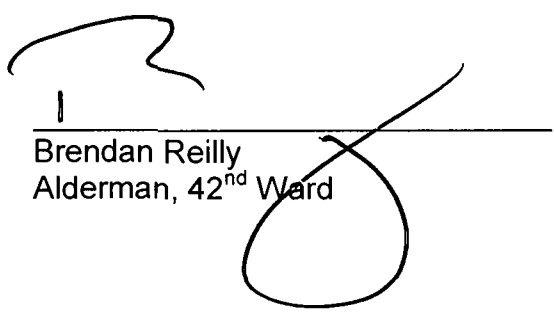

Brendan Reilly
Alderman, 42nd Ward



CITY OF CHICAGO

DEPARTMENT OF BUILDINGS

Sign Permit Application

| | | | | |
|---|---------------------------------|---|-------------------------------|---|
| APPROVAL NUMBER | APPLICATION NUMBER 100506703 | ANNUAL FEE | WORK CODE | DRAWINGS ATTACHED <input type="checkbox"/> YES <input type="checkbox"/> NO |
| DATE OF APPLICATION 08/30/2013 | | TYPE OF SIGN FLAT OR BOX | | |
| ADDRESS OF SIGN 549 N WELLS ST, 60654- | | LENGTH | FT 36 | IN |
| BUILDING | ORIGINAL PERMIT NUMBER | HEIGHT | FT 10 | IN 6 |
| TYPE OF PERMIT NEW CONSTRUCTION (SIGN) | | AREA | SQ. FT 378 | WEIGHT |
| PAYER OF ANNUAL INSPECTION ABU-GHAZALEH, WALID 188 N WELLS ST CHICAGO, IL 60606 (312)504-5347 | | SIGN HEIGHT ABOVE GRADE/ROOF | | FT 37 |
| SIGN MANUFACTURER METROMEDIA | | SHAPE OF SIGN REGULAR | | |
| ADDRESS WHERE SIGN CAN BE SEEN PRIOR TO ERECTION | | SIGN WILL READ VARIOUS ACCOUNTS | | |
| TICKET NUMBER 0 | RE INSPECTION CONTROL NUMBER | NO. OF LAMPS 2 | TOTAL WATTAGE 800 | |
| TYPE OF SUPPORT FOR SIGN BUILDING | | TYPE OF LAMP HIGH DENSITY DISCHARGE | | |
| SIGN BOARD SUPPORT MEMBERS OTHER | | NO. OF BALLAST/TRANSFORMERS 2 | INPUT OF TRANSFORMERS 120V | |
| ANNUAL FEE _____ | | CONTRACTOR WILL INSTALL <input checked="" type="checkbox"/> FEEDERS <input checked="" type="checkbox"/> CUSTOMER LEADS | | |
| CONSTRUCTION FEE 1,000.00 | | TYPE OF SWITCH KNIFE | | |
| 1017 B FEE _____ | | LOCATION OF SWITCH OUTSIDE SIGN | | |
| TOTAL FEE 1,000.00 | | SIGN LOCATION RE-PERMIT SIGN (ORIGINAL PERMIT #378369) PER MELL ORDINANCE FOR FLAT WALL SIGN ON WEST ELEVATION. | | |
| AMOUNT PAID 500.00 | | | | |
| BALANCE DUE \$ 500.00 | | | | |

The undersigned certify that the statements in this application are true and correct and that all work done under the proposed permit will conform to the requirements of the Chicago Municipal Code

| | | | | |
|----------------------|--|--------------|-------------------------------------|--------|
| REG. NO. | E94475 | BOND NO. | RFO. NO. | N93194 |
| OBJECT CONTR. | PNA ELECTRICAL SERVICES INC. | SIGN ERECTOR | LINCOLN SERVICES | SIGNER |
| ADDRESS | 6454 S. TALMAN AVENUE CHICAGO, IL 60629 | ADDRESS | P.O. BOX 64479 CHICAGO IL, 60664 | |
| SUPERVISOR SIGNATURE | <i>[Signature]</i> | SIGNATURE | <i>[Signature]</i> | |

The permit issued on this application will authorize only signs here applied for. If other signs are to be erected they must be covered by additional permits

City of Chicago
Rahm Emanuel, Mayor



Department of Buildings
Felicia Davis, Commissioner

| | | | | | |
|---|---|------------|---------------------|---|---|
| TYPE OF BUSINESS COMMERCIAL Other: _____ Name: _____ LIC #: _____ Renewal Date: _____ <hr/> Projects Over: <input checked="" type="checkbox"/> Private Property <input checked="" type="checkbox"/> Public Way Grant Permit # _____ <input type="checkbox"/> Planned Development/Manufacturing PMD/PD# _____ Zoning District: <u>DX</u> Other: _____ <hr/> TYPE OF SIGN <input checked="" type="checkbox"/> ADVERTISING <input checked="" type="checkbox"/> ILLUMINATE <input type="checkbox"/> MOVEABLE <input type="checkbox"/> BUSINESS <input type="checkbox"/> FLASHING <hr/> TOTAL STREET FRONTAGE OF LOT (IN FEET) <u>200</u> <hr/> TOTAL AREA OF NEW SIGN (SQ FT.) <u>378</u> <hr/> TOTAL AREA OF ALL SIGNS ON LOT (SQ FT.) <u>816</u> <hr/> HEIGHT OF SIGN ABOVE GRADE (TO TOP) <u>47ft 6in</u> <hr/> DISTANCE OF CURB LINE OUTER EDGE (ft) <u>10</u> DISTANCE OF STRUCTURE INNER EDGE (ft) <u>10</u> <hr/> DISTANCE FROM (ft). A. PUBLIC PARK (OVER 10 ACRES) <u>1,000</u> B. EXPRESSWAY (IF LESS THAN 1,000 FT.) <u>1,000</u> C. RESIDENCE DISTRICT (ADVERTISING SIGNS ONLY) <u>250</u> <hr/> IF REPLACEMENT SIGN OR CHANGE OF FACE, WHAT DOES THE EXISTING SIGN READ? Original Payee: _____ Landmark Hold: <input type="checkbox"/> Status: _____ <hr/> ZONING (OFFICE USE ONLY) | SIGN BOND REQUIRED? <input checked="" type="checkbox"/> YES <hr/> COUNCIL ORDER REQUIRED <input type="checkbox"/> YES <hr/> IS SPECIAL PERMISSION REQUIRED FROM CHIEF ELECTRICAL <input type="checkbox"/> YES <hr/> IF YES, ATTACH LETTER OF REQUEST <hr/> TIME STAMP <hr/> <table style="width:100%; border: none;"> <tr> <td style="width:70%; border: none;">SIGN CLERK</td> <td style="width:30%; border: none;">APPROVED FOR PERMIT</td> </tr> <tr> <td style="border: none;">-</td> <td style="border: none;">-</td> </tr> </table> <hr/> REMARKS | SIGN CLERK | APPROVED FOR PERMIT | - | - |
| SIGN CLERK | APPROVED FOR PERMIT | | | | |
| - | - | | | | |

CITY OF CHICAGO
DEPARTMENT OF ZONING AND LAND USE PLANNING
SIGN SITE PLAN
(ALL INFORMATION MUST BE COMPLETED AND LEGIBLE)

Site Address: 549 N Wells St, Chicago, IL 60654 (West Elevation) 1 of 1 applications

Sign Company: Project Outdoor LLC Rep Name: Walid Abu-Ghazaleh

Phone (312) 504 -5347 EXT _____ (Below: Building, streets and location of sign on lot or structure)
 North



South

SIGN USE:

- Bus. ID (On-premise)
- Business Lice. #*
- Advertising (Off-premise)

PERMIT TYPE:

- New Construction
- Change of Face
- Previous Permit #
378369

TOTAL SQUARE FOOTAGE:

Square footage of this proposed sign 378
 Gross area of all proposed signs 378
 Area of all existing signs
 (not including proposed) on Zoning Lot 9056

TYPE OF SIGN:

- Flat Wall
- Freestanding
- Awning
- Marquee
- High Rise Building
- Projecting Private
- Projecting Public Way
- Public Way Use -Permit #

SIGN CHARACTERISTICS:

- Non- Illuminated
- Illuminated
- Changing Image
- Video Display
- Flashing

DISTANCE FROM:

Curb Line: 14'
 Expressway, Toll Roads
 or Major Route
 (n/a if over 1000 ft) 850'
 Park (over 10 acres) 1985'
 Residential Zone 1200'
 Existing Off-premise on
 same side of street: 80'

Signature: _____

Date: 4-15-2014



City of Chicago



Or2014-227

Office of the City Clerk

Document Tracking Sheet

| | |
|---------------------------------|---|
| Meeting Date: | 5/28/2014 |
| Sponsor(s): | Tunney (44) |
| Type: | Order |
| Title: | Issuance of permits for sign(s)/signboard(s) at 3401 N Clark St |
| Committee(s) Assignment: | Committee on Zoning, Landmarks and Building Standards |

COMMITTEE ON ZONING, LANDMARKS & BUILDING STANDARDS

(signs)

ORDERED, That the Commissioner of Buildings is hereby directed to issue a sign permit to:

**M-K Signs, Inc.
4900 N. Elston Ave
Chicago, IL 60630**

For the erection of a sign/signboard/awning over 24 feet in height and/or 100 square feet (in area of one face) at:

**The Big Cheese Poutinerie
3401 N. Clark Street
Chicago, IL 60657**

Dimensions: Length: 58 feet - 0 inches Height: 4 feet - 0 inches

Height above grade/roof to top of sign: 13 feet - 0 inches

TOTAL SQUARE FOOT AREA: 232 square feet

Such sign(s) shall comply with all applicable provisions of TITLE 17 of the Chicago Zoning Ordinance and all other applicable provisions of the Municipal Code of the CITY OF CHICAGO governing the construction and maintenance of outdoor sign, signboards and structures..

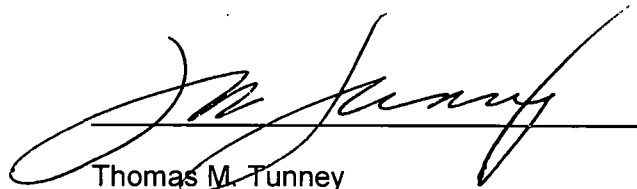
A handwritten signature in black ink, appearing to read "Thomas M. Tunney", is written over a horizontal line.

Thomas M. Tunney

May 28, 2014

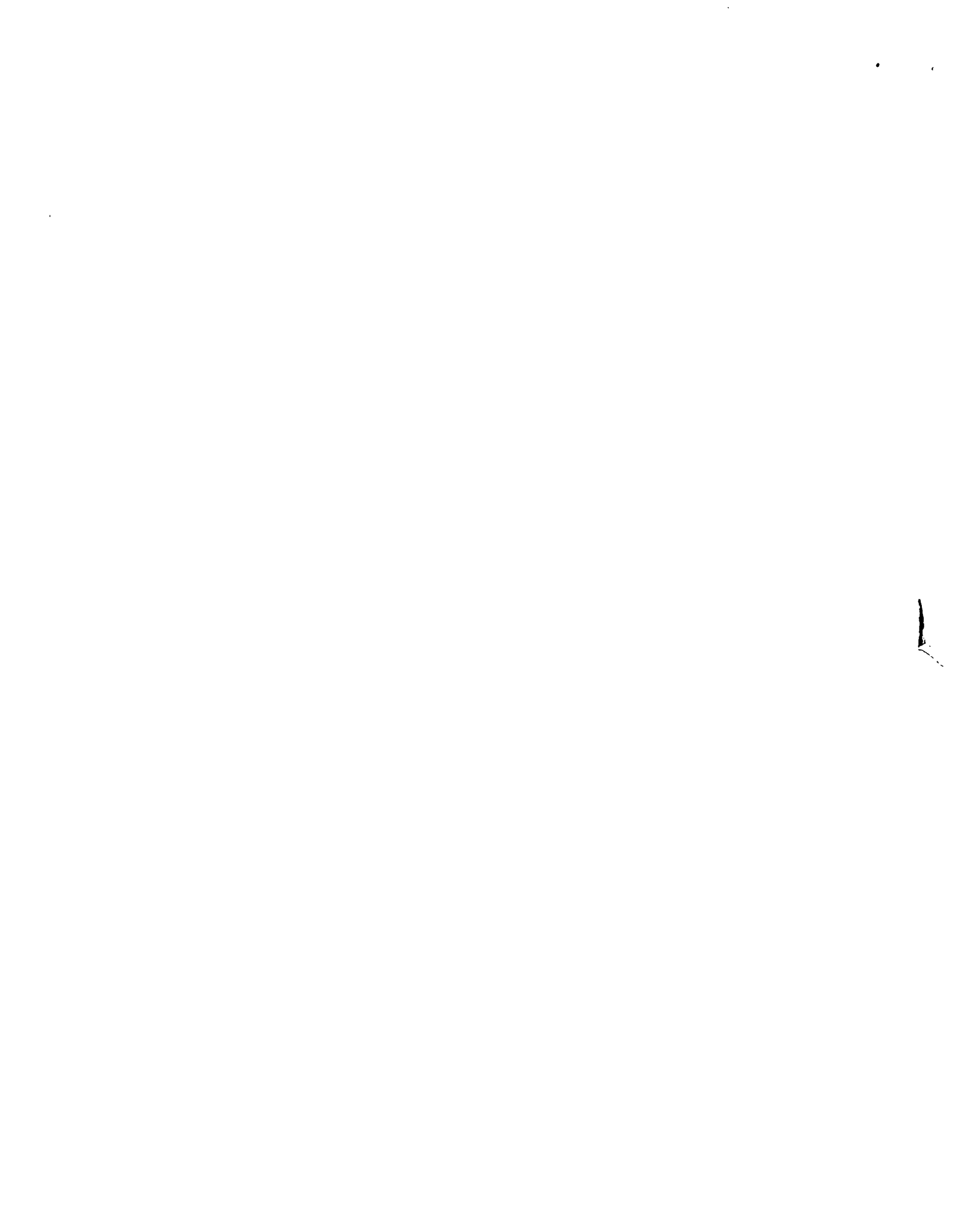

58' x 4'
OVERALL

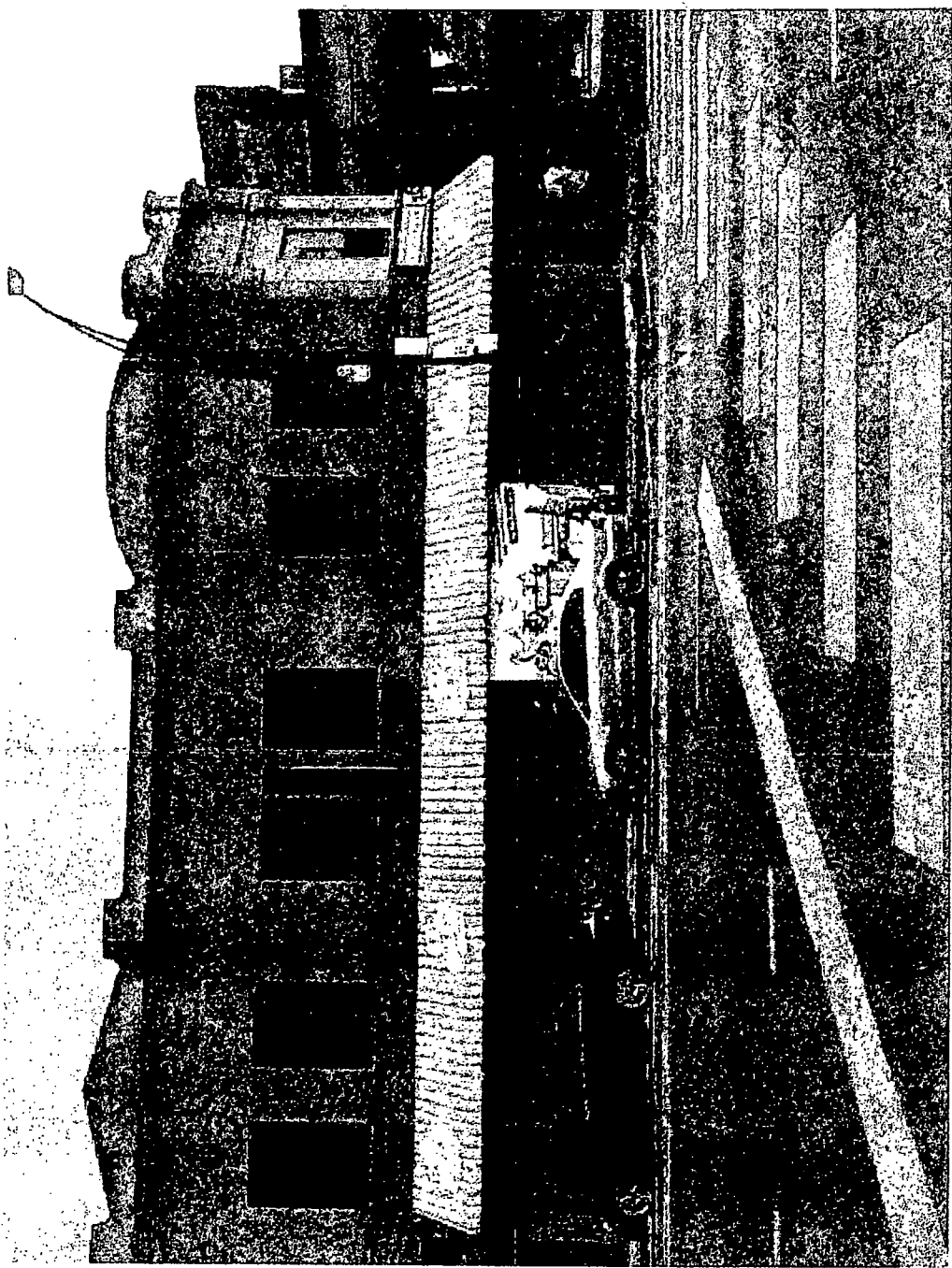

APPROVED: _____ DATE: _____

M-K SIGNS
CHICAGO
4900 N. ELSTON AVE.
CHICAGO, IL 60630
773/505-0000
773/505-9275
E-MAIL: art@mkpl@mksigns.net

THE BIG CHEESE
CHICAGO, IL

Colors represented in this drawing are for presentation purposes only. They will not match your finished product exactly. Actual color samples can be obtained from your sales representative. This design is the original and unpublished work of MK SIGNS and may not be reproduced, copied or exhibited in any fashion without the expressed written consent of MK SIGNS. The rights to this design may be purchased.

| DATE | REVISION | SCALE | DATE |
|------|----------|----------------|----------------|
| | | N.T.S. | 2-7-14 |
| | | DESIGNER | SALES |
| | | LM | TC |
| | | FILE | DRAWING NUMBER |
| | | The Big Cheese | 2271-2 |

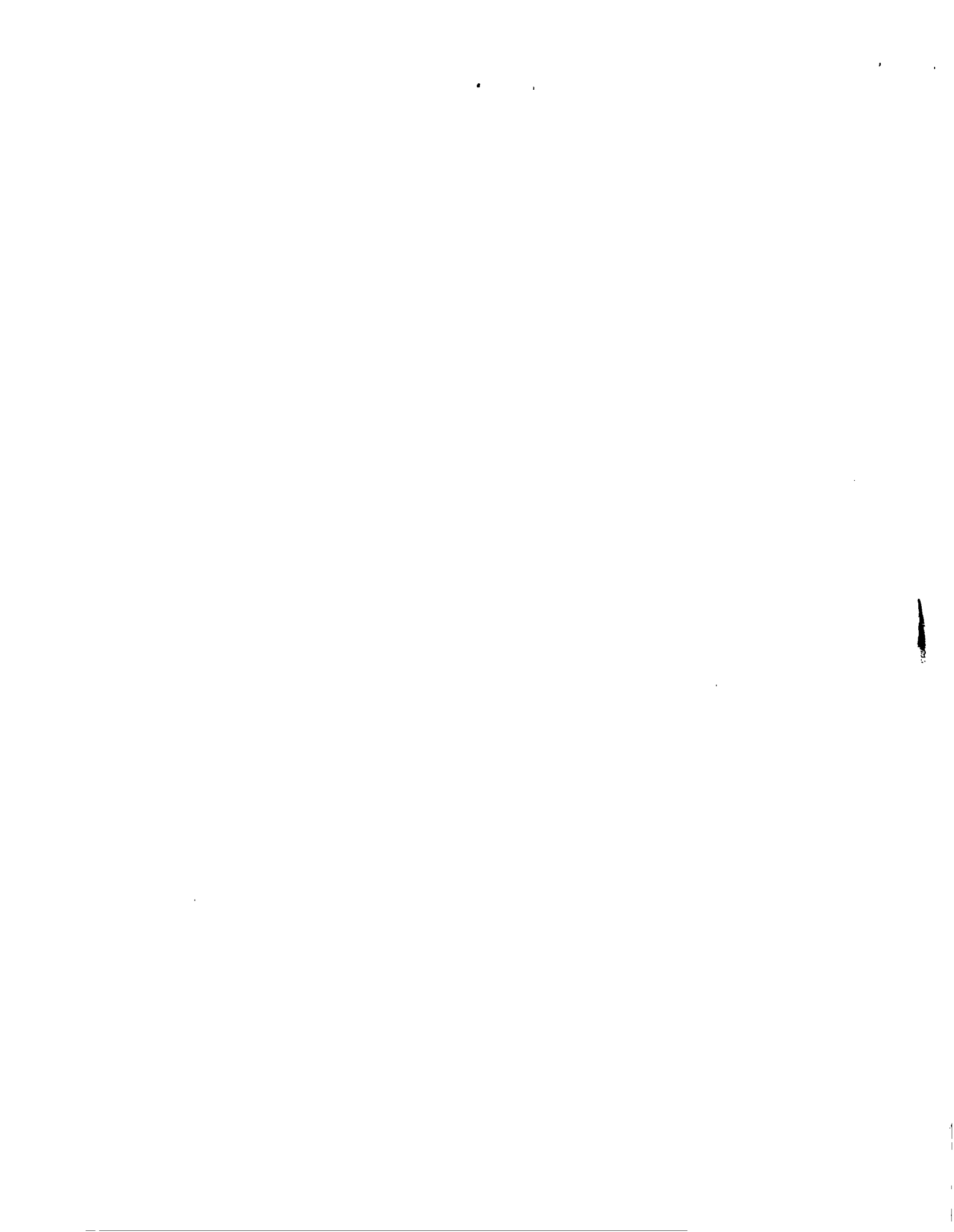

58'-0"

OVERALL LENGTH OF AWNING



APPROVED: _____

DATE: _____

M-K SIGNS
4900 N. ELSTON AVE
CHICAGO, IL 60630

770/555-2273
770/555-2273
E-MAIL: art@mkpl@mksigns.net

THE BIG CHEESE
CHICAGO, IL

Colors represented in this drawing are for presentation purposes only. They will not match your finished product exactly. Actual color samples can be obtained from your sales representative. This design is the original and unpublished work of MK SIGNS and may not be reproduced, copied or exhibited in any fashion without the expressed written consent of MK SIGNS. The rights to this design may be purchased.

| DATE | REVISION | SCALE | DATE |
|------|----------|----------------|----------------|
| | | N.T.S. | 2-7-14 |
| | | DESIGNER | SALES |
| | | LM | TC |
| | | FILE | DRAWING NUMBER |
| | | The Big Cheese | 2271-1 |



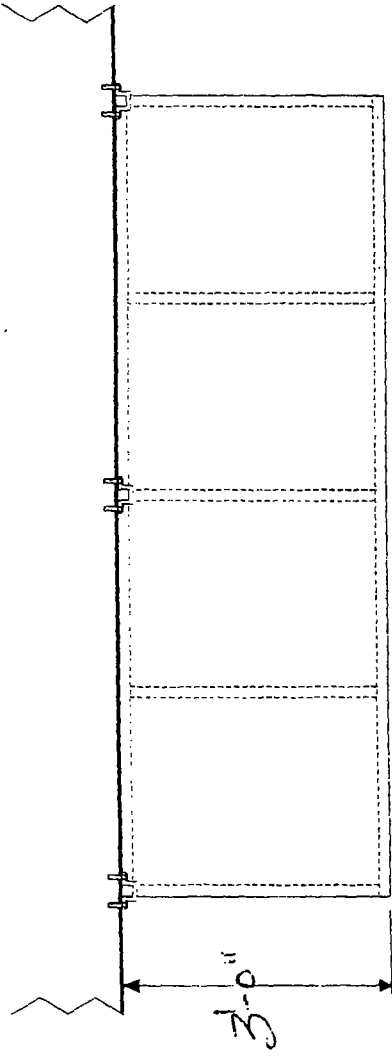
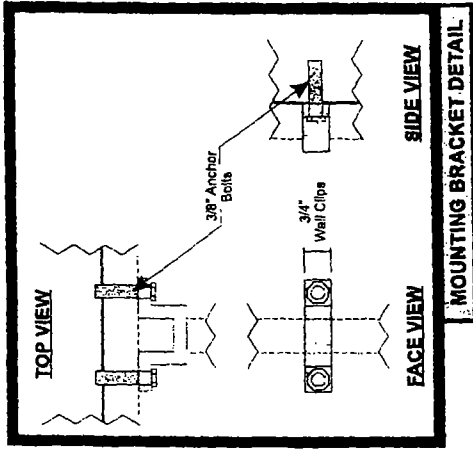

TOP VIEW

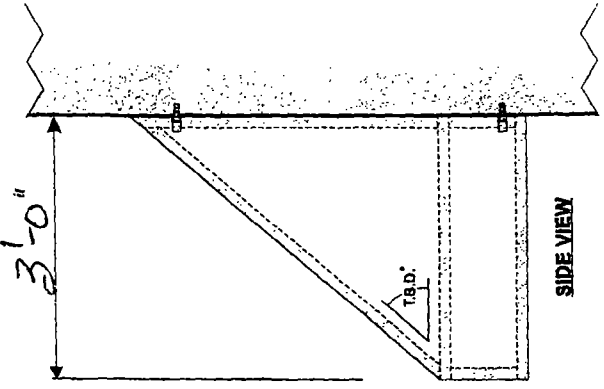

SIDE VIEW

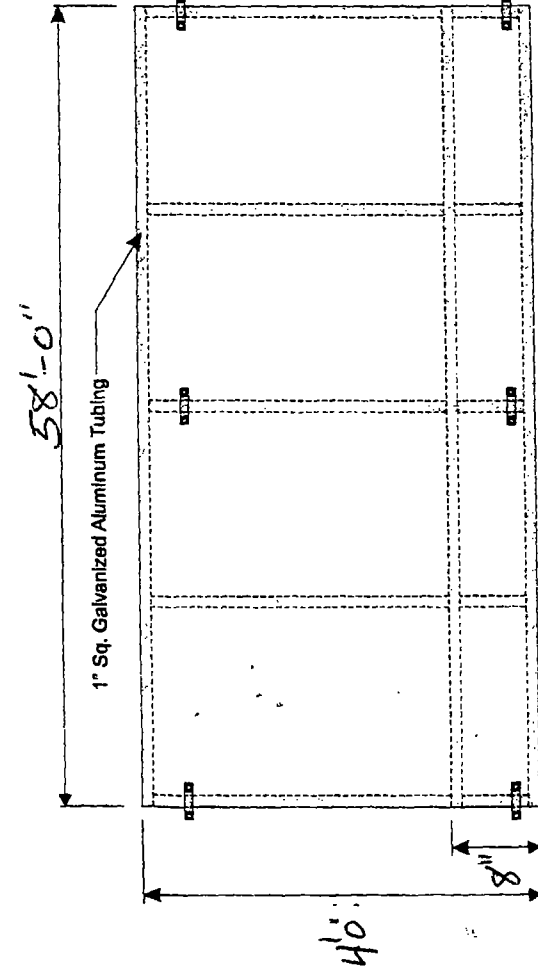

FACE VIEW

APPROVED: _____

DATE: _____

M-K SIGNS
CHICAGO
4900 N. ELSTON AVE
CHICAGO, IL 60630
E-MAIL: mkdept@mksigns.net

AWNING
THE BIG CHEESE

Colors represented in this drawing are for presentation purposes only. They will not match your finished product exactly. Actual color samples can be obtained from your sales representative. This design is the original and unpublished work of MK SIGNS and may not be reproduced, copied or exhibited in any fashion without the expressed written consent of MK SIGNS. The rights to this design may be purchased.

| | |
|----------------|----------|
| DATE | 10/30/11 |
| SALES | N.T.S. |
| DESIGNER | JTF |
| FILE | AWNING |
| DRAWING NUMBER | 0000 |



CITY OF CHICAGO

DEPARTMENT OF BUILDINGS

Sign Permit Application

| | | | | |
|-----------------|---------------------------------|------------|-----------|---|
| APPROVAL NUMBER | APPLICATION NUMBER 100531213 | ANNUAL FEE | WORK CODE | DRAWINGS ATTACHED <input type="checkbox"/> YES <input type="checkbox"/> NO |
|-----------------|---------------------------------|------------|-----------|---|

| | | |
|---|--------------------------------|--------------------|
| DATE OF APPLICATION 03/13/2014 | | |
| ADDRESS OF SIGN 3401 N CLARK ST, 60657- | | |
| BUILDING ORIGINAL PERMIT NUMBER | | |
| TYPE OF PERMIT NEW CONSTRUCTION (SIGN) | | |
| PAYER OF ANNUAL INSPECTION STADNICKI, MICHAEL 3401 NORTH CLARK STREET CHICAGO, IL 60657 (773)545-4444 | | |
| SIGN MANUFACTURER M-K SIGNS, INC, CHICAGO, IL | | |
| ADDRESS WHERE SIGN CAN BE SEEN PRIOR TO ERECTION | | |
| TICKET NUMBER 0 | REINSPECTION CONTROL NUMBER | |
| TYPE OF SUPPORT FOR SIGN BUILDING | | |
| SIGN BOARD SUPPORT MEMBERS STEEL | | |
| ANNUAL FEE _____ | CONSTRUCTION FEE <u>200.00</u> | Check # for Zoning |
| 1017 B FEE _____ | TOTAL FEE <u>200.00</u> | |
| AMOUNT PAID <u>200.00</u> | BALANCE DUE _____ | Check # for DCAP |

| | | | | | |
|--|--------------|---------|---|------------|---------|
| TYPE OF SIGN AWNING | | | | | |
| LENGTH | FT 58 | IN 0 | HEIGHT | FT 4 | IN 0 |
| AREA | SQ FT 232 | WEIGHT | | LBS 250 | |
| SIGN HEIGHT ABOVE GRADE/ROOF | | | | | FT 9 |
| SHAPE OF SIGN REGULAR | | | | | |
| SIGN WILL READ FIVE BIG CHEESE LOGOS | | | | | |
| NO OF LAMPS | | | TOTAL WATTAGE | | |
| TYPE OF LAMP | | | | | |
| NO OF BALLAST/TRANSFORMERS | | | INPUT OF TRANSFORMERS | | |
| CONTRACTOR WILL INSTALL | | | <input checked="" type="checkbox"/> FEEDERS <input checked="" type="checkbox"/> CUSTOMER LEADS | | |
| TYPE OF SWITCH | | | | | |
| LOCATION OF SWITCH | | | | | |
| SIGN LOCATION BIG CHEESE AWNING ACROSS BUILDING | | | | | |

The undersigned certify that the statements in this application are true and correct and that all work done under the proposed permit will conform to the requirements of the Chicago Municipal Code

| | |
|---|--------|
| REG NO | E05834 |
| ELECT CONTR M-K SIGNS, INC. | ELECTR |
| ADDRESS 4900 N. ELSTON AVE. CHICAGO, IL 60630 | |
| SUPERVISOR SIGNATURE | |

| | | |
|---|--------|--------|
| BOND NO | REG NO | E05834 |
| SIGN ERECTOR M-K SIGNS, INC. | SIGNER | |
| ADDRESS 4900 N. ELSTON AVE. CHICAGO IL, 60630 | | |
| SIGNATURE | | |

The permit issued on this application will authorize only signs here applied for. If other signs are to be erected they must be covered by additional permits

City of Chicago
Rahm Emanuel, Mayor



Department of Buildings
Felicia Davis, Commissioner

1. 2. 3.



| | |
|--|--|
| TYPE OF BUSINESS <u>COM DINING</u> Other: _____ Name: <u>THE BIG CHEESE POUTINERE</u> LIC #: <u>2320212</u> Renewal Date: _____ | SIGN BOND REQUIRED? <input type="checkbox"/> YES COUNCIL ORDER REQUIRED <input checked="" type="checkbox"/> YES IS SPECIAL PERMISSION REQUIRED FROM CHIEF ELECTRICAL <input type="checkbox"/> YES IF YES, ATTACH LETTER OF REQUEST |
| Projects Over: <input checked="" type="checkbox"/> Private Property <input checked="" type="checkbox"/> Public Way Grant Permit #. <u>1111548</u> <input type="checkbox"/> Planned Development/Manufacturing PMD/PD#: _____ Zoning District <u>C1</u> Other: _____ | TIME STAMP |
| TYPE OF SIGN: <input type="checkbox"/> ADVERTISING <input type="checkbox"/> ILLUMINATE <input type="checkbox"/> MOVEABLE <input checked="" type="checkbox"/> BUSINESS <input type="checkbox"/> FLASHING | |
| TOTAL STREET FRONTAGE OF LOT (IN FEET) _____ <u>60</u> | |
| TOTAL AREA OF NEW SIGN (SQ.FT.) _____ <u>232</u> | |
| TOTAL AREA OF ALL SIGNS ON LOT (SQ.FT.) _____ <u>1</u> | |
| HEIGHT OF SIGN ABOVE GRADE (TO TOP) _____ <u>13ft 0in</u> | |
| DISTANCE OF CURB LINE OUTER EDGE (ft) _____ <u>3</u> DISTANCE OF STRUCTURE INNER EDGE (ft) _____ <u>6</u> | SIGN CLERK _____ APPROVED FOR PERMIT _____ |
| DISTANCE FROM (ft): A. PUBLIC PARK (OVER 10 ACRES) _____ B. EXPRESSWAY (IF LESS THAN 1,000 FT.) _____ C. RESIDENCE DISTRICT (ADVERTISING SIGNS ONLY) _____ | REMARKS |
| IF REPLACEMENT SIGN OR CHANGE OF FACE, WHAT DOES THE EXISTING SIGN READ? Original Payee: _____ | |
| Landmark Hold: <input type="checkbox"/> Status: _____ | |
| ZONING (OFFICE USE ONLY) | |

**CITY OF CHICAGO
DEPARTMENT OF ZONING AND LAND USE PLANNING
SIGN SITE PLAN
(ALL INFORMATION MUST BE COMPLETED AND LEGIBLE)**

Site Address: 3401 N CLARK ST. 3 of 3 applications

Sign Company: M-K SIGNS, INC Rep Name: ANTHONY CILIA

Phone (773) 545 - 4444 EXT (Below: Building, streets and location of sign on lot or structure)
North

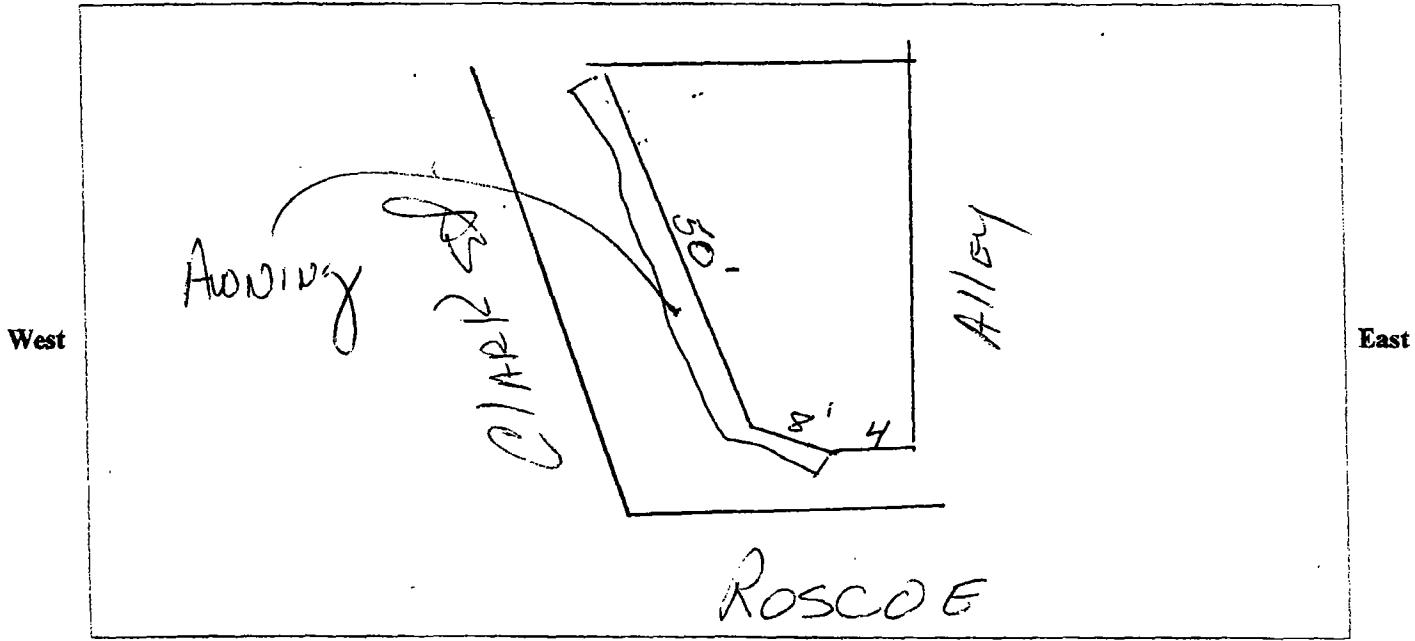

SIGN USE:
Bus. ID (On-premise)
Business Lice. #
2320212
Advertising (Off-premise)

PERMIT TYPE:
New Construction
Change of Face
Previous Permit #

TYPE OF SIGN:
Flat Wall
Freestanding
Awning
Marquee
High Rise Building
Projecting Private
Projecting Public Way
Public Way Use -Permit #
1111548

SIGN CHARACTERISTICS:
Non-Illuminated
Illuminated
Changing Image
Video Display
Flashing

DISTANCE FROM:
Curb Line: 6'
Expressway, Toll Roads
or Major Route
(n/a if over 1000 ft)
Park (over 10 acres)
Residential Zone
Existing Off-premise on
same side of street:

TOTAL SQUARE FOOTAGE:
Square footage of this proposed sign 232
Gross area of all proposed signs 280
Area of all existing signs
(not including proposed) on Zoning Lot 0

Signature: Anthony Cilia

Date: 4-8-14

PUBLIC WAY USE UNIT: PERMIT INFORMATION SHEET

03/04/2014 - Anthony Bertuca

DBA Name The Big Cheese Poutinerie
Location 3401 N. CLARK ST.
Zip Code 60657
Account Number 388586
Site Number 1
Area PERMIT
Permit Type AWN
Permit Number 1111548

Next steps: Department of Buildings – Permit process for signs

Your Public Way Use permit number is shown above. This number is to be used for each item on your DOB application and is needed for the Buildings (DOB) online sign application located @ www.cityofchicago.org/buildings. All signs, canopies, banners, marquees and awnings require a buildings permit. Only a licensed sign erector may apply for the Buildings permit online. The Buildings permit application will ask for the Public Way Use permit number supplied above. For additional information please contact the Buildings Department at (312) 744-3400.

Please return the completed Public Way Use application to City Hall - 121 N. LaSalle Street, Chicago, IL 60602 Room 800. The completed application package must include a copy of the completed DOB application and the Public Way Use application. The Public Way Use application must contain the Alderman's signature, site plans on 8 1/2 X 11 paper, photos of the item(s), the signed Acceptance letter and a copy of the insurance certificate. For additional information please contact BACP at (312)-74-GOBIZ (312-744-6249).



City of Chicago



Or2014-243

Office of the City Clerk

Document Tracking Sheet

| | |
|---------------------------------|--|
| Meeting Date: | 5/28/2014 |
| Sponsor(s): | Tunney (44) |
| Type: | Order |
| Title: | Issuance of permits for sign(s)/signboard(s) at 3046 N Halsted St |
| Committee(s) Assignment: | Committee on Zoning, Landmarks and Building Standards |

COMMITTEE ON ZONING, LANDMARKS & BUILDING STANDARDS

(signs)

ORDERED, That the Commissioner of Buildings is hereby directed to issue a sign permit to:

**Signco, Inc.
1327 31st Ave
Melrose Park, IL60160**

For the erection of **two** signs/signboards over 100 square feet (in area of one fact) at:

**Petco
3046 N. Halsted St.
Chicago, IL 60657**

Dimensions: Length: 26 feet – 8 inches Height: 6 feet - 10 inches

Height above grade/roof to top of sign: 22 feet - 0 inches

TOTAL SQUARE FOOT AREA: 182 square feet

Such sign(s) shall comply with all applicable provisions of TITLE 17 of the Chicago Zoning Ordinance and all other applicable provisions of the Municipal Code of the CITY OF CHICAGO governing the construction and maintenance of outdoor sign, signboards and structures.

A handwritten signature in black ink, appearing to read "Tom Tunney", written over a horizontal line.

Thomas M. Tunney
Alderman 44th Ward
May 28, 2014



City of Chicago



Or2014-216

Office of the City Clerk

Document Tracking Sheet

| | |
|---------------------------------|---|
| Meeting Date: | 5/28/2014 |
| Sponsor(s): | Cappleman (46) |
| Type: | Order |
| Title: | Issuance of permits for sign(s)/signboard(s) at 4646 N Marine Dr |
| Committee(s) Assignment: | Committee on Zoning, Landmarks and Building Standards |

ORDERED, That the Commissioner of the Building Department is hereby directed to issue a sign permit to: (Contractor's name and address)

ROEDA SIGNS & SCREENTECH
16931 STATE STREET
SOUTH HOLLAND, IL 60473

For the erection of a sign / signboard over twenty-four (24) feet in height and / or over one hundred (100) square feet (in area of one face) at:

WEISS MEMORIAL HOSPITAL
4646 N. MARINE DRIVE
CHICAGO, IL 60640

With the following Dimensions, height, and square foot area:

Dimensions: Length: 8 feet Height 40 feet
Height Above Grade / Roof to top of Sign: 0 feet
Total Square Foot Area: 320 Square Feet

Such signs shall comply with all provisions of Title 17 of the Chicago Zoning Ordinance and all other applicable provisions of the Municipal Code of the City of Chicago governing the construction and maintenance of outdoor signs, sign boards, and structures.

James Cappelman

Alderman, 46 Ward



City of Chicago

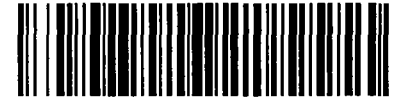

Or2014-244

Office of the City Clerk

Document Tracking Sheet

| | |
|---------------------------------|--|
| Meeting Date: | 5/28/2014 |
| Sponsor(s): | Pawar (47) |
| Type: | Order |
| Title: | Issuance of permits for sign(s)/signboard(s) at 3300 N Campbell Ave |
| Committee(s) Assignment: | Committee on Zoning, Landmarks and Building Standards |

Committee on Zoning, Landmarks, and Building Standards
May 28, 2014
City Council Meeting

(Signs)

ORDERED, That the Commissioner of Buildings is hereby directed to issue a sign permit to:

South Water Signs
934 N. Church Road
Elmhurst, IL 60126

For the erection of sign / signboard over 24 feet in height and / or over 100 square feet (in area of one face) at:

DeVry Universtiy
3300 N. Campbell Ave.
Chicago, IL 60618

Dimensions: Length ____ 10' ____ **Height** ____ 20' ____

Height above grade / roof to top of sign ____ 20' ____

TOTAL SQUARE FOOT AREA ____ 200' ____

Such Sign (s) shall comply with all applicable provisions of Title 17 of the Chicago Zoning Ordinance and all other Applicable provisions of the Municipal Code of the City of Chicago Governing the construction and maintenance of outdoor signs, sign boards and structures.

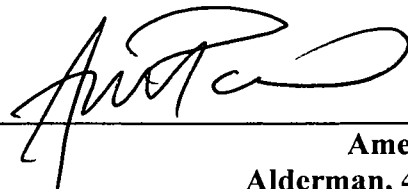

Ameya Pawar
Alderman, 47th Ward